

REGOLAMENT TAL-KUMMISSJONI (UE) Nru 1301/2014**tat-18 ta' Novembru 2014****dwar l-ispeċifikazzjonijiet tekniċi tal-interoperabbiltà relatati mas-sottosistema tal-“enerġija” tas-sistema ferrovjarja tal-Unjoni****(Test b'rilevanza għaż-ŻEE)**

IL-KUMMISSJONI EWROPEA,

Wara li kkunsidrat it-Trattat dwar il-Funzjonament tal-Unjoni Ewropea,

Wara li kkunsidrat id-Direttiva 2008/57/KE tal-Parlament Ewropew u tal-Kunsill tas-17 ta' Ġunju 2008 dwar l-interoperabbiltà tas-sistema ferrovjarja fil-Komunità ⁽¹⁾, u b'mod partikulari l-Artikolu 6(1) tagħha,

Billi:

- (1) Skont l-Artikolu 12 tar-Regolament (KE) Nru 881/2004 tal-Parlament Ewropew u tal-Kunsill ⁽²⁾, l-Aġenzija Ferrovjarja Ewropea (minn hawn 'il quddiem imsejha “l-Aġenzija”) għandha tiżgura li l-ispeċifikazzjonijiet tekniċi tal-interoperabbiltà (minn hawn 'il quddiem imsejhin it-“TSIs”) jiġu adattati għall-progress tekniku, għax-xejriet tas-suq u għall-htigijiet soċjali, u għandha tipproponi lill-Kummissjoni l-emendi għat-TSIs li hija tqis li jkunu meħtieġa.
- (2) Permezz tad-Deciżjoni C(2010) 2576 tad-29 ta' April 2010, il-Kummissjoni tat mandat lill-Aġenzija biex tiżviluppa u tanalizza mill-ġdid it-TSIs bil-għan li testendi l-ambitu tagħhom għas-sistema ferrovjarja kollha tal-Unjoni. Skont it-termini ta' dak il-mandat, l-Aġenzija ntalbet testendi l-ambitu tat-TSI relatata mas-sottosistema tal-“enerġija” għas-sistema ferrovjarja kollha tal-Unjoni Ewropea.
- (3) Fl-24 ta' Dicembru 2012, l-Aġenzija harġet rakkomandazzjoni dwar l-emendi għat-TSI relatata mas-sottosistema tal-“enerġija” (ERA/REC/11-2012/INT).
- (4) Biex inlaħħqu mal-progress teknoloġiku u nhegġu l-modernizzazzjoni, għandhom jinġiebu 'l quddiem soluzzjonijiet innovattivi, u għandha tkun permessal-implimentazzjoni tagħhom skont ċerti kundizzjonijiet. Fejn tiġi proposta soluzzjoni innovattiva, il-manifattur jew ir-rappreżentant awtorizzat tiegħu għandu jiddikjara kif it-tali soluzzjoni tvarja mit-taqsima rilevanti tat-TSI jew kif din tikkomplimentaha; wara dan, is-soluzzjoni innovattiva għandha tiġi vvalutata mill-Kummissjoni. Jekk din il-valutazzjoni tkun waħda favorevoli, l-Aġenzija għandha tfasal l-ispeċifikazzjonijiet operattivi u tal-interfaċċja x-xierqa tas-soluzzjoni innovattiva, u għandha tiżviluppa l-metodi ta' valutazzjoni rilevanti.
- (5) It-TSI dwar l-enerġija stabbilita b'dan ir-Regolament ma tindirizzax ir-rekwiżiti essenzjali kollha. Skont l-Artikolu 5(6) tad-Direttiva 2008/57/KE, l-aspetti tekniċi li mhumiex koperti minn din it-TSI għandhom jiġu identifikati bħala “punti mhux konklużi” li huma rregolati mir-regoli nazzjonali li japplikaw f'kull Stat Membru.
- (6) Skont l-Artikolu 17(3) tad-Direttiva 2008/57/KE, l-Istati Membri għandhom jinnotifikaw lill-Kummissjoni u lill-Istati Membri l-oħra dwar il-proċeduri għall-valutazzjoni tal-konformità u għall-verifika li għandhom jintużaw għall-kazijiet speċifiċi, kif ukoll dwar il-korpi li għandhom ir-responsabbiltà jwettqu dawn il-proċeduri. Għandu jiġi previst l-istess obbligu għall-punti mhux konklużi.
- (7) Bhalissa, it-traffiku ferrovjarju jopera skont ftehimiet eżistenti ta' natura nazzjonali, bilaterali, multinazzjonali jew internazzjonali. Huwa importanti li dawn il-ftehimiet ma jtellfux il-progress attwali u futur biex tinkiseb l-interoperabbiltà. Għalhekk, l-Istati Membri għandhom jinnotifikaw lill-Kummissjoni bit-tali ftehimiet.
- (8) Skont l-Artikolu 11(5) tad-Direttiva 2008/57/KE, it-TSI dwar l-enerġija għandha tippermetti, għal perjodu limitat, li l-kostitwenti tal-interoperabbiltà jkunu inkorporati f'sottosistemi mingħajr ċertifikazzjoni, jekk jiġu ssodisfati ċerti kundizzjonijiet.

⁽¹⁾ ĠUL 191, 18.7.2008, p. 1.⁽²⁾ Ir-Regolament (KE) Nru 881/2004 tal-Parlament Ewropew u tal-Kunsill tad-29 ta' April 2004 li jistabbilixxi Aġenzija Ewropea tal-Ferroviji (GUL 164, 30.4.2004, p. 1).

- (9) Ghalhekk, id-Deciżjonijiet tal-Kummissjoni 2008/284/KE ⁽¹⁾ u 2011/274/UE ⁽²⁾ għandhom jithassru.
- (10) Sabiex jiġu evitati piż amministrattivi u kostijiet żejda, wara t-thassir tagħhom, id-Deciżjonijiet 2008/284/KE u 2011/274/UE għandhom jibqgħu japplikaw għas-sottosistemi u għall-proġetti msemmijin fl-Artikolu 9(1)(a) tad-Direttiva 2008/57/KE.
- (11) Sabiex tiġi żgurata l-interoperabbiltà tas-sottosistema tal-enerġija, għandu jiġi stabbilit pjan għall-implimentazzjoni progressiva ta' din is-sottosistema.
- (12) Minhabba li s-sistema tal-ġbir tad-dejta tiġbor id-dejta minn sistemi tal-kejl tal-enerġija li jkunu jinsabu abbord, l-Istati Membri għandhom jiżguraw li, għall-għanijiet tal-hruġ tal-kontijiet, tiġi żviluppata u aċċettata sistema li tkun tista' tirċievi dik id-dejta.
- (13) Il-miżuri stipulati f'dan ir-Regolament huma skont l-opinjoni tal-Kumitat stabbilit skont l-Artikolu 29(1) tad-Direttiva 2008/57/KE,

ADOTTAT DAN IR-REGOLAMENT:

Artikolu 1

Suġġett

B'dan qed tiġi adottata l-ispeċifikazzjoni teknika tal-interoperabbiltà (it-TSI) relatata mas-sottosistema tal-"enerġija" tas-sistema ferrovjarja tal-Unjoni Ewropea kollha, kif stipulata fl-Anness.

Artikolu 2

Kamp ta' applikazzjoni

1. It-TSI għandha tapplika għal kwalunkwe sottosistema tal-"enerġija" ġdida, aġġornata jew rinnovata tas-sistema ferrovjarja tal-Unjoni Ewropea, kif iddefinit fil-punt 2.2 tal-Anness II tad-Direttiva 2008/57/KE.
 2. Mingħajr hsara għall-Artikoli 7 u 8 u għall-punt 7.2 tal-Anness, it-TSI għandha tapplika għal-linji ferrovjarji l-godda fl-Unjoni Ewropea li jiddaħhlu fis-servizz mill-1 ta' Jannar 2015.
 3. It-TSI m'għandhiex tapplika għall-infrastruttura eżistenti tas-sistema ferrovjarja tal-Unjoni Ewropea li tkun diġà ddahhlet fis-servizz fin-netwerk kollu ta' kwalunkwe Stat Membru, jew f'parti minnu, fl-1 ta' Jannar 2015, hlief meta din tiġġedded jew tiġi mmodernizzata skont l-Artikolu 20 tad-Direttiva 2008/57/KE u skont it-Taqsima 7.3 tal-Anness.
 4. It-TSI għandha tapplika għan-netwerks li ġejjin:
 - (a) in-netwerk tas-sistema ferrovjarja trans-Ewropea konvenzjonali, kif iddefinit fit-Taqsima 1.1 tal-Anness I tad-Direttiva 2008/57/KE;
 - (b) in-netwerk tas-sistema ferrovjarja trans-Ewropea ta' veloċità għolja (TEN), kif iddefinit fit-Taqsima 2.1 tal-Anness I tad-Direttiva 2008/57/KE; u
 - (c) il-partijiet l-oħra tan-netwerk tas-sistema ferrovjarja tal-Unjoni;
- u m'għandhiex tkopri l-każijiet imsemmijin fl-Artikolu 1(3) tad-Direttiva 2008/57/KE.
5. It-TSI għandha tapplika għan-netwerks li għandhom wisa' nominali bejn il-binarji tal-linja ferrovjarja ta' 1 435 mm, 1 520 mm, 1 524 mm, 1 600 mm u 1 668 mm.
 6. Il-binarju metriku mhux inkluz fil-kamp ta' applikazzjoni tekniku ta' din it-TSI.

⁽¹⁾ Id-Deciżjoni tal-Kummissjoni 2008/284/KE tas-6 ta' Marzu 2008 dwar speċifikazzjoni teknika għall-interoperabbiltà (STI) rigward is-subsistema tal-enerġija tas-sistema ferrovjarja trans-Ewropea ta' veloċità għolja (ĠUL 104, 14.4.2008, p. 1).

⁽²⁾ Id-Deciżjoni tal-Kummissjoni 2011/274/UE tas-26 ta' April 2011 dwar speċifikazzjoni teknika għall-interoperabbiltà relatata mas-subsistema tal-"enerġija" tas-sistema ferrovjarja konvenzjonali trans-Ewropea (ĠUL 126, 14.5.2011, p. 1).

Artikolu 3

Punti mhux konklużi

1. Għall-kwistjonijiet ikklassifikati bħala “punti mhux konklużi” msemminj fl-Appendiċi F tat-TSI, il-kundizzjonijiet li għandhom jiġu ssodisfati għall-verifika tal-interoperabbiltà skont l-Artikolu 17(3) tad-Direttiva 2008/57/KE għandhom ikunu r-regoli nazzjonali li japplikaw fl-Istat Membru li jawtorizza t-tqeghid fis-servizz tas-sottosistema koperta minn dan ir-Regolament.
2. Fi żmien sitt xhur mid-dhul fis-sehh ta' dan ir-Regolament, kull Stat Membru għandu jibgħat lill-Istati Membri l-oħra u lill-Kummissjoni t-tagħrif li ġej, sakemm dan ma jkunx diġà ntbagħtilhom skont id-Deċizzjonijiet tal-Kummissjoni 2008/284/KE u 2011/274/UE:
 - (a) ir-regoli nazzjonali msemminj fil-paragrafu 1;
 - (b) il-proċeduri għall-valutazzjoni tal-konformità u għall-verifika li għandhom jitwettqu sabiex jiġu applikati r-regoli nazzjonali msemminj fil-paragrafu 1;
 - (c) il-korpi mahturin skont l-Artikolu 17(3) tad-Direttiva 2008/57/KE biex iwettqu l-proċeduri għall-valutazzjoni tal-konformità u għall-verifika fir-rigward tal-punti mhux konklużi.

Artikolu 4

Każijiet speċifiċi

1. Għall-każijiet speċifiċi msemminj fil-punt 7.4.2 tal-Anness ta' dan ir-Regolament, il-kundizzjonijiet li għandhom jiġu ssodisfati għall-verifika tal-interoperabbiltà skont l-Artikolu 17(3) tad-Direttiva 2008/57/KE għandhom ikunu r-regoli nazzjonali li japplikaw fl-Istat Membru li jawtorizza t-tqeghid fis-servizz tas-sottosistema koperta minn dan ir-Regolament.
2. Fi żmien sitt xhur mid-dhul fis-sehh ta' dan ir-Regolament, kull Stat Membru għandu jibgħat lill-Istati Membri l-oħra u lill-Kummissjoni t-tagħrif li ġej:
 - (a) ir-regoli nazzjonali msemminj fil-paragrafu 1;
 - (b) il-proċeduri għall-valutazzjoni tal-konformità u għall-verifika li għandhom jitwettqu sabiex jiġu applikati r-regoli nazzjonali msemminj fil-paragrafu 1;
 - (c) il-korpi mahturin skont l-Artikolu 17(3) tad-Direttiva 2008/57/KE biex iwettqu l-proċeduri għall-valutazzjoni tal-konformità u għall-verifika fil-każijiet speċifiċi msemminj fil-punt 7.4.2 tal-Anness.

Artikolu 5

Notifika ta' ftehimiet bilaterali

1. Sa mhux iktar tard mill-1 ta' Lulju 2015, l-Istati Membri għandhom jinnotifikaw lill-Kummissjoni dwar kwalunkwe ftehim ta' natura nazzjonali, bilaterali, multilaterali jew internazzjonali li jkun jeżisti bejn l-Istati Membri u impriża/i ferrovjarja/i, il-manigers tal-infrastruttura jew pajjiżi li mhumix membri, u li jkun hemm bżonnu minhabba n-natura speċifika hafna jew lokali tas-servizz ferrovjarju mahsub jew li jkun joffri livelli sinifikanti ta' interoperabbiltà lokali jew reġjonali.

Dak l-obbligu ma japplikax għal ftehimiet li jkunu diġà ġew innotifikati skont id-Deċizzjoni tal-Kummissjoni 2008/284/KE.

2. L-Istati Membri għandhom jinnotifikaw lill-Kummissjoni dwar kwalunkwe ftehim jew emenda għal ftehimiet eżistenti li tkun se ssir fil-futur.

Artikolu 6

Proġetti li jinsabu fi stadju avvanzat tal-iżvilupp

Skont l-Artikolu 9(3) tad-Direttiva 2008/57/KE, fi żmien sena mid-dhul fis-sehh ta' dan ir-Regolament, kull Stat Membru għandu jibgħat lill-Kummissjoni l-lista ta' proġetti li jkunu qed jiġu implimentati fit-territorju tiegħu u li jkunu fi stadju avvanzat tal-iżvilupp.

Artikolu 7

Ċertifikat ta' verifika "tal-KE"

1. Jista' jinhareġ ċertifikat ta' verifika "tal-KE" għal sottosistema li fiha kostitwenti tal-interoperabbiltà li m'għandhomx dikjarazzjoni tal-konformità jew tal-idoneità għall-użu "tal-KE" waqt perjodu ta' tranżizzjoni li jispicċa fil-31 ta' Mejju 2021, dejjem jekk jiġu ssodisfati r-rekwiżiti stabbiliti fil-punt 6.3 tal-Anness.
2. Il-produzzjoni, l-aġġornament jew it-tiġdid tas-sottosistema bl-użu ta' kostitwenti tal-interoperabbiltà mhux iċċertifikati għandu jitlesta fil-perjodu ta' tranżizzjoni stipulat fil-paragrafu 1, inkluż it-tqeghid fis-servizz tagħha.
3. Waqt il-perjodu ta' tranżizzjoni stipulat fil-paragrafu 1:
 - (a) il-korp innotifikat għandu jidentifika sewwa r-raġunijiet għan-nuqqas ta' ċertifikazzjoni ta' kwalunkwe kostitwent tal-interoperabbiltà qabel ma johroġ iċ-ċertifikat "tal-KE" skont l-Artikolu 18 tad-Direttiva 2008/57/KE;
 - (b) skont l-Artikolu 16(2)(c) tad-Direttiva 2004/49/KE tal-Parlament Ewropew u tal-Kunsill ⁽¹⁾, l-awtoritajiet nazzjonali tas-sikurezza għandhom jirrapportaw dwar l-użu ta' kostitwenti tal-interoperabbiltà mhux iċċertifikati fil-kuntest tal-proċeduri ta' awtorizzazzjoni fir-rapport annwali tagħhom imsemmi fl-Artikolu 18 tad-Direttiva 2004/49/KE.
4. Mill-1 ta' Jannar 2016, il-kostitwenti tal-interoperabbiltà li jkunu għadhom kemm ġew prodotti għandhom ikunu koperti mid-dikjarazzjoni tal-konformità jew tal-idoneità għall-użu tal-KE.

Artikolu 8

Valutazzjoni tal-konformità

1. Il-proċeduri għall-valutazzjoni tal-konformità u tal-idoneità għall-użu u għall-verifika "tal-KE" stabbiliti fit-Taqsima 6 tal-Anness għandhom jissejju fuq il-moduli stabbiliti fid-Deciżjoni tal-Kummissjoni 2010/713/UE ⁽²⁾.
2. Iċ-ċertifikat tal-eżaminazzjoni tat-tip jew tad-disinn tal-kostitwenti tal-interoperabbiltà għandu jkun validu għal perjodu ta' seba' snin. Matul dak il-perjodu, jistgħu jiddaħhlu fis-servizz kostitwenti ġodda tal-istess tip minghajr ma ssirilhom valutazzjoni ġdida tal-konformità.
3. Iċ-ċertifikati msemmijin fil-paragrafu 2 li jkunu nharġu skont ir-rekwiżiti tad-Deciżjoni tal-Kummissjoni 2011/274/UE (dwar it-TSI tal-ENE CR) jew skont ir-rekwiżiti tad-Deciżjoni tal-Kummissjoni 2008/284/KE (dwar it-TSI tal-ENE HS) se jibqgħu validi sad-data tal-iskadenza tagħhom stabbilita oriġinarjament, minghajr ma jkun hemm bżonn li ssir valutazzjoni ġdida tal-konformità. Sabiex jiġġedded ċertifikat, id-disinn jew it-tip għandhom jiġu vvalutati mill-ġdid biss għar-rekwiżiti l-ġodda jew għal dawk li jkunu nbidlu li huma stabbiliti fl-Anness ta' dan ir-Regolament.

Artikolu 9

Implimentazzjoni

1. It-Taqsima 7 tal-Anness tistabbilixxi l-passi li għandhom jittiehdu biex tiġi implimentata sottosistema tal-enerġija li tkun interoperabbli għalkollox.

Minghajr hsara għall-Artikolu 20 tad-Direttiva 2008/57/KE, l-Istati Membri għandhom ihejju pjan ta' implimentazzjoni nazzjonali, li fih jiddeskrivu l-azzjonijiet li beħsiebhom jiehdu biex jikkonformaw ma' din it-TSI, skont it-Taqsima 7 tal-Anness. L-Istati Membri għandhom jibagħtu l-pjanijiet ta' implimentazzjoni nazzjonali tagħhom lill-Istati Membri l-oħra u lill-Kummissjoni sal-31 ta' Dicembru 2015. L-Istati Membri li diġà bagħtu l-pjanijiet ta' implimentazzjoni tagħhom m'għandhomx għalfejn jerggħu jibagħtuhom.

⁽¹⁾ Id-Direttiva 2004/49/KE tal-Parlament Ewropew u tal-Kunsill tad-29 ta' April 2004 fuq is-sigurtà tal-linji tal-ferrovija tal-Komunità u li temenda d-Direttiva tal-Kunsill 95/18/KE fuq l-ghoti tal-licenzi tal-imprizi tal-linji tal-ferrovija u d-Direttiva 2001/14/KE fuq l-allokazzjoni tal-kapaċità tal-infrastruttura tal-linji tal-ferrovija u l-intaxxar tal-piżijiet għall-użu tal-infrastruttura tal-linji tal-ferrovija u ċ-ċertifikazzjoni tas-sigurtà (Id-Direttiva tas-Sigurtà Tal-Linji tal-Ferrovija) (ĠU L 164, 30.4.2004, p. 44).

⁽²⁾ Id-Deciżjoni tal-Kummissjoni 2010/713/UE tad-9 ta' Novembru 2010 dwar moduli għall-proċeduri għal valutazzjoni ta' konformità, adattezza għall-użu, u verifika tal-KE li għandhom jintużaw fl-ispeċifikazzjonijiet tekniċi għal interoperabbiltà adottati skont id-Direttiva 2008/57/KE tal-Parlament Ewropew u tal-Kunsill (GU L 319, 4.12.2010, p. 1).

2. Skont l-Artikolu 20 tad-Direttiva 2008/57/KE, l-Istati Membri għandhom jinnotifikaw lill-Kummissjoni bit-tagħrif li ġej f'każ li jkun hemm bżonn ta' awtorizzazzjoni ġdida u t-TSI ma tiġix applikata għalkollox:

- ir-raġuni għaliex it-TSI mhix applikata għalkollox,
- il-karatteristiċi tekniċi li japplikaw minflok it-TSI,
- il-korpi li għandhom ir-responsabbiltà japplikaw il-proċedura ta' verifika msemmija fl-Artikolu 18 tad-Direttiva 2008/57/KE.

3. Tliet snin wara d-dhul fis-seħh ta' dan ir-Regolament, l-Istati Membri għandhom jibagħtu lill-Kummissjoni rapport dwar l-implimentazzjoni tal-Artikolu 20 tad-Direttiva 2008/57/KE dwar is-sottosistema tal-enerġija. Dan ir-rapport għandu jiġi diskuss mill-Kumitat stabbilit bl-Artikolu 29 tad-Direttiva 2008/57/KE u, fejn ikun xieraq, it-TSI mogħtija fl-Anness għandha tiġi adattata għalih.

4. Minbarra l-implimentazzjoni tas-sistema tal-ġbir tad-dejta dwar l-enerġija ta' fuq l-art iddefinita fil-punt 7.2.4 tal-Anness u mingħajr hsara għad-dispożizzjonijiet tal-punt 4.2.8.2.8 tal-Anness tar-Regolament tal-Kummissjoni (UE) Nru 1302/2014 ⁽¹⁾ (it-TSI il-ġdida tal-LOC & PAS), l-Istati Membri għandhom jiżguraw li, sentejn wara li jiġu konklużi l-punti mhux konklużi msemmijin fil-punt 4.2.17 tal-Anness, tiġi implimentata sistema ta' saldu ta' fuq l-art li tkun tista' tircievi d-dejta mingħand sistema tal-ġbir tad-dejta u taċċettaha għall-hruġ tal-kontijiet. Is-sistema ta' saldu ta' fuq l-art għandha tkun tista' tiskambja d-dejta miġbura dwar il-kontijiet tal-enerġija ma' sistemi ta' saldu oħrajn, tivvalida d-dejta miġbura dwar il-kontijiet tal-enerġija u talloka d-dejta dwar il-konsum lill-partijiet it-tajbin. Dan għandu jsir billi titqies il-leġiżlazzjoni rilevanti dwar is-suq tal-enerġija.

Artikolu 10

Soluzzjonijiet innovattivi

1. Biex jinżamm il-pass mal-progress teknoloġiku, jista' jkun hemm bżonn ta' soluzzjonijiet innovattivi li ma jkunux konformi mal-ispeċifikazzjonijiet stabbiliti fl-Anness jew li għalihom ma jkunux jistgħu jiġu applikati l-metodi tal-valutazzjoni mogħtija fl-Anness.

2. Is-soluzzjonijiet innovattivi jistgħu jkunu relatati mas-sottosistema tal-enerġija, mal-partijiet tagħha u mal-kostitwenti tal-interoperabbiltà tagħha.

3. Jekk tiġi proposta soluzzjoni innovattiva, il-manifattur jew ir-rappreżentant awtorizzat tiegħu, stabbilit fl-Unjoni, għandu jiddikjara kif it-tali soluzzjoni tvarja mid-dispożizzjoni rilevanti ta' din it-TSI jew kif din tikkomplementaha, u għandu jibgħat id-differenzi lill-Kummissjoni għall-analiżi. Il-Kummissjoni tista' titlob lill-Aġenzija tagħti l-opinjoni tagħha dwar is-soluzzjoni innovattiva proposta.

4. Il-Kummissjoni għandha tagħti l-opinjoni tagħha dwar is-soluzzjoni innovattiva proposta. Jekk din l-opinjoni tkun waħda favorevoli, l-ispeċifikazzjonijiet operattivi u tal-interfaċċja x-xierqa u l-metodu ta' valutazzjoni, li jridu jiddaħhlu fit-TSI sabiex din is-soluzzjoni innovattiva tkun tista' tintuża, għandhom jiġu żviluppati u mbagħad integrati fit-TSI matul il-proċess ta' reviżjoni skont l-Artikolu 6 tad-Direttiva 2008/57/KE. Jekk l-opinjoni ma tkunx waħda favorevoli, is-soluzzjoni innovattiva proposta ma tistax tintuża.

5. Sa ma tiġi analizzata mill-ġdid it-TSI, l-opinjoni favorevoli mogħtija mill-Kummissjoni għandha titqies bħala mezz ta' konformità aċċettabbli mar-rekwiżiti essenzjali tad-Direttiva 2008/57/KE, u tista' tintuża għall-valutazzjoni tas-sottosistema.

Artikolu 11

Thassir

Id-Deciżjonijiet 2008/284/KE u 2011/274/UE għandhom jithassru b'effett mill-1 ta' Jannar 2015.

Madankollu, huma għandhom jibqgħu japplikaw:

- (a) għas-sottosistemi mogħtija awtorizzazzjoni skont dawk id-Deciżjonijiet;
- (b) għall-proġetti għal sottosistemi ġodda, imġedda jew imtejba li, fi żmien il-pubblikazzjoni ta' dan ir-Regolament, ikunu jinsabu fi stadju avanzat tal-iżvilupp, jew li dwarhom ikun għaddej xi kuntratt.

⁽¹⁾ Ir-Regolament tal-Kummissjoni (UE) Nru 1302/2014 tat-18 ta' Novembru 2014 dwar l-ispeċifikazzjoni teknika għall-interoperabbiltà relatata mas-subsistema ta' "vetturi ferrovjarji — lokomottivi u vetturi ferrovjarji għat-trasport tal-passiġġieri" tas-sistema ferrovjarja tal-Unjoni Ewropea (Ara l-paġna 228 ta' dan il-Gurnal Uffiċjali).

*Artikolu 12***Dhul fis-sehh**

Dan ir-Regolament ghandu jidhol fis-sehh fl-ghoxrin jum wara dak tal-pubblikazzjoni tieghu f'*Il-Ġurnal Uffiċjali tal-Unjoni Ewropea*.

Ghandu japplika mill-1 ta' Jannar 2015. Madankollu, qabel l-1 ta' Jannar 2015, tista' tinghata awtorizzazzjoni ghat-tqeghid fis-servizz skont it-TSI, kif stabbilit fl-Anness ta' dan ir-Regolament.

Dan ir-Regolament ghandu jorbot fl-intier tieghu u japplika direttament fl-Istati Membri kollha.

Magħmul fi Brussell, it-18 ta' Novembru 2014.

Għall-Kummissjoni
Il-President
Jean-Claude JUNCKER

ANNEX

WERREJ

1.	Introduction	188
1.1.	Technical scope	188
1.2.	Geographical scope	188
1.3.	Content of this TSI	188
2.	Description of the energy subsystem	188
2.1.	Definition	188
2.1.1.	Power supply	189
2.1.2.	Geometry of the overhead contact line (OCL) and quality of current collection	189
2.2.	Interfaces with other subsystems	189
2.2.1.	Introduction	189
2.2.2.	Interfaces of this TSI with the Safety in railway tunnels TSI	189
3.	Essential requirements	189
4.	Characterisation of the subsystem	191
4.1.	Introduction	191
4.2.	Functional and technical specifications of the subsystem	191
4.2.1.	General provisions	191
4.2.2.	Basic parameters characterising the energy subsystem	192
4.2.3.	Voltage and frequency	192
4.2.4.	Parameters relating to supply system performance	192
4.2.5.	Current capacity, DC systems, trains at standstill	193
4.2.6.	Regenerative braking	193
4.2.7.	Electrical protection coordination arrangements	193
4.2.8.	Harmonics and dynamic effects for AC traction power supply systems	193
4.2.9.	Geometry of the overhead contact line	193
4.2.10.	Pantograph gauge	194
4.2.11.	Mean contact force	205
4.2.12.	Dynamic behaviour and quality of current collection	205
4.2.13.	Pantograph spacing for overhead contact line design	205
4.2.14.	Contact wire material	196
4.2.15.	Phase separation sections	196
4.2.16.	System separation sections	197

4.2.17.	On-ground energy data collecting system	197
4.2.18.	Protective provisions against electric shock	197
4.3.	Functional and technical specifications of the interfaces	198
4.3.1.	General requirements	198
4.3.2.	Interface with Rolling Stock subsystem.	198
4.3.3.	Interface with Infrastructure subsystem	199
4.3.4.	Interface with Control — Command and Signalling subsystems	199
4.3.5.	Interface with Operation and traffic management subsystem	199
4.4.	Operating rules	199
4.5.	Maintenance rules	199
4.6.	Professional qualifications	200
4.7.	Health and safety conditions	200
5.	Interoperability constituents	200
5.1.	List of constituents	200
5.2.	Constituents' performances and specifications	200
5.2.1.	Overhead contact line	200
6.	Assessment of conformity of the interoperability constituents and EC verification of the subsystems	201
6.1.	Interoperability constituents	201
6.1.1.	Conformity assessment procedures	201
6.1.2.	Application of modules	201
6.1.3.	Innovative solutions for interoperability constituents	202
6.1.4.	Particular assessment procedure for the interoperability constituent — overhead contact line	202
6.1.5.	EC declaration of conformity of interoperability constituent OCL	203
6.2.	Energy subsystem	203
6.2.1.	General provisions	203
6.2.2.	Application of modules	203
6.2.3.	Innovative solutions	204
6.2.4.	Particular assessment procedures for energy subsystem	204
6.3.	Sub-system containing interoperability constituents not holding an EC declaration	205
6.3.1.	Conditions	205
6.3.2.	Documentation	205
6.3.3.	Maintenance of the subsystems certified according to 6.3.1	206
7.	Implementation of the Energy TSI	206
7.1.	Application of this TSI to railway lines	206
7.2.	Application of this TSI to new, renewed or upgraded railway lines	206

7.2.1.	Introduction	206
7.2.2.	Implementation plan for voltage and frequency	206
7.2.3.	Implementation plan for OCL geometry	207
7.2.4.	Implementation of the on-ground energy data collecting system	207
7.3.	Application of this TSI to existing lines	207
7.3.1.	Introduction	207
7.3.2.	Upgrading/renewal of the OCL and/or the power supply	208
7.3.3.	Parameters related to maintenance	208
7.3.4.	Existing subsystem that are not subject to a renewal or upgrading project	208
7.4.	Specific cases	208
7.4.1.	General	208
7.4.2.	List of specific cases	208
Appendix A	— Conformity assessment of interoperability constituents	212
Appendix B	— EC verification of the energy subsystem	213
Appendix C	— Mean useful voltage	215
Appendix D	— Specification of the pantograph gauge	216
Appendix E	— List of referenced standards	224
Appendix F	— List of open points	225
Appendix G	— Glossary	226

1. INTRODUCTION

1.1. **Technical scope**

- (1) This TSI concerns the energy subsystem and part of the maintenance subsystem of the Union rail system in accordance with Article 1 of Directive 2008/57/EC.
- (2) The energy subsystem is defined in Annex II (2.2) to Directive 2008/57/EC.
- (3) The technical scope of this TSI is further defined in Article 2 of this Regulation.

1.2. **Geographical scope**

The geographical scope of this TSI is defined in Article 2(4) of this Regulation.

1.3. **Content of this TSI**

- (1) In accordance with Article 5(3) of Directive 2008/57/EC, this TSI:
 - (a) indicates its intended scope (Section 2);
 - (b) lays down essential requirements for the energy subsystem (Section 3);
 - (c) establishes the functional and technical specifications to be met by the subsystem and its interfaces vis-à-vis other subsystems (Section 4);
 - (d) specifies the interoperability constituents and interfaces which must be covered by European specifications, including European standards, which are necessary to achieve interoperability within the Union rail system (Section 5);
 - (e) states, in each case under consideration, which procedures are to be used in order to assess the conformity or the suitability for use of the interoperability constituents, on the one hand, or the EC verification of the subsystems, on the other hand (Section 6);
 - (f) sets out the implementation plan of this TSI (Section 7);
 - (g) indicates, for the staff concerned, the professional qualifications and health and safety conditions required at work for the operation and maintenance of the subsystem, as well as for the implementation of this TSI (Section 4).
- (2) In accordance with Article 5(5) of the Directive 2008/57/EC, provisions for specific cases are indicated in Section 7.
- (3) Requirements in this TSI are valid for all track gauge systems within the scope of this TSI, unless a paragraph refers to specific track gauge systems or to specific nominal track gauges.

2. DESCRIPTION OF THE ENERGY SUBSYSTEM

2.1. **Definition**

- (1) This TSI covers all fixed installations necessary to achieve interoperability that are required to supply traction energy to a train.
- (2) The energy subsystem consists of:
 - (a) substations: connected on the primary side to the high-voltage grid, with transformation of the high-voltage to a voltage and/or conversion to a power supply system suitable for the trains. On the secondary side, substations are connected to the railway contact line system;
 - (b) sectioning locations: electrical equipment located at intermediate locations between substations to supply and parallel contact lines and to provide protection, isolation and auxiliary supplies;

- (c) separation sections: equipment required to provide the transition between electrically different systems or between different phases of the same electrical system;
 - (d) contact line system: a system that distributes the electrical energy to the trains running on the route and transmits it to the trains by means of current collectors. The contact line system is also equipped with manually or remotely controlled disconnectors which are required to isolate sections or groups of the contact line system according to operational necessity. Feeder lines are also part of the contact line system;
 - (e) return circuit: all conductors which form the intended path for the traction return current. Therefore, so far as this aspect is concerned, the return circuit is part of the energy subsystem and has an interface with the infrastructure subsystem.
- (3) In accordance with Annex II, Section 2.2 of Directive 2008/57/EC, the trackside of the electricity consumption measuring system, referred to in this TSI as on-ground energy data collection system, is set out in point 4.2.17 of this TSI.

2.1.1. *Power supply*

- (1) The objective of the power supply system is to supply every train with power in order to meet the planned timetable.
- (2) Basic parameters for power supply system are defined in point 4.2.

2.1.2. *Geometry of the overhead contact line (OCL) and quality of current collection*

- (1) The objective is to ensure reliable and continuous power transfer from the power supply system to the rolling stock. The interaction between the overhead contact line and the pantograph is an important aspect of interoperability.
- (2) Basic parameters referring to the geometry of the OCL and quality of current collection are set out in point 4.2.

2.2. **Interfaces with other subsystems**

2.2.1. *Introduction*

- (1) The energy subsystem interfaces with other subsystems of the rail system in order to achieve the envisaged performance. These subsystems are listed below:
 - (a) Rolling stock;
 - (b) Infrastructure;
 - (c) Trackside control command and signalling;
 - (d) On-board control command and signalling;
 - (e) Operation and traffic management.
- (2) Point 4.3 of this TSI sets out the functional and technical specification of these interfaces.

2.2.2. *Interfaces of this TSI with the Safety in railway tunnels TSI*

Requirements relating to the energy subsystem for safety in railway tunnels are set out in the TSI relating to Safety in railway tunnels.

3. ESSENTIAL REQUIREMENTS

The following table indicates basic parameters of this TSI and their correspondence to the essential requirements as set out and numbered in Annex III of Directive 2008/57/EC.

TSI point	Title of TSI point	Safety	R&A	Health	Environmental protection	Tech. Compatibility	Accessibility
4.2.3	Voltage and frequency	—	—	—	—	1.5 2.2.3	—
4.2.4	Parameters relating to supply system performance	—	—	—	—	1.5 2.2.3	—
4.2.5	Current capacity, DC systems, trains at standstill	—	—	—	—	1.5 2.2.3	—
4.2.6	Regenerative braking	—	—	—	1.4.1 1.4.3	1.5 2.2.3	—
4.2.7	Electrical protection coordination arrangements	2.2.1	—	—	—	1.5	—
4.2.8	Harmonics and dynamic effects for AC traction power supply systems	—	—	—	1.4.1 1.4.3	1.5	—
4.2.9	Geometry of the overhead contact line	—	—	—	—	1.5 2.2.3	—
4.2.10	Pantograph gauge	—	—	—	—	1.5 2.2.3	—
4.2.11	Mean contact force	—	—	—	—	1.5 2.2.3	—
4.2.12	Dynamic behaviour and quality of current collection	—	—	—	1.4.1 2.2.2	1.5 2.2.3	—
4.2.13	Pantograph spacing for overhead contact line design	—	—	—	—	1.5 2.2.3	—
4.2.14	Contact wire material	—	—	1.3.1 1.3.2	1.4.1	1.5 2.2.3	—
4.2.15	Phase separation sections	2.2.1	—	—	1.4.1 1.4.3	1.5 2.2.3	—
4.2.16	System separation sections	2.2.1	—	—	1.4.1 1.4.3	1.5 2.2.3	—
4.2.17	On-ground energy data collecting system	—	—	—	—	1.5	—

TSI point	Title of TSI point	Safety	R&A	Health	Environmental protection	Tech. Compatibility	Accessibility
4.2.18	Protective provisions against electric shock	1.1.1 1.1.3 2.2.1	—	—	1.4.1 1.4.3 2.2.2	1.5	—
4.4	Operating rules	2.2.1	—	—	—	1.5	—
4.5	Maintenance rules	1.1.1 2.2.1	1.2	—	—	1.5 2.2.3	—
4.6	Professional qualifications	2.2.1	—	—	—	—	—
4.7	Health and safety conditions	1.1.1 1.1.3 2.2.1	—	—	1.4.1 1.4.3 2.2.2	—	—

4. CHARACTERISATION OF THE SUBSYSTEM

4.1. Introduction

- (1) The whole rail system, to which Directive 2008/57/EC applies and of which the energy subsystem is a part, is an integrated system whose consistency needs to be verified. This consistency must be checked, in particular, with regard to the specifications of the energy subsystem, its interfaces vis-à-vis the system in which it is integrated, as well as the operating and maintenance rules. The functional and technical specifications of the subsystem and its interfaces, described in points 4.2 and 4.3, do not impose the use of specific technologies or technical solutions, except where this is strictly necessary for the interoperability of the rail network.
- (2) Innovative solutions for interoperability, which do not fulfil requirements specified in this TSI and are not assessable as stated in this TSI, require new specifications and/or new assessment methods. In order to allow technological innovation, these specifications and assessment methods shall be developed by the process for innovative solutions described in points 6.1.3 and 6.2.3.
- (3) Taking account of all the applicable essential requirements, the energy subsystem is characterised by the specifications set out in points 4.2 to 4.7.
- (4) Procedures for the EC verification of the energy subsystem are indicated in point 6.2.4 and Appendix B, Table B.1, of this TSI.
- (5) For specific cases, see point 7.4.
- (6) Where reference is made to EN standards in this TSI, any variations called “national deviations” or “special national conditions” in the EN standards are not applicable and do not form part of this TSI.

4.2. Functional and technical specifications of the subsystem

4.2.1. General provisions

The performance to be achieved by the energy subsystem is specified at least by the required performance of the rail system with respect to:

- (a) maximum line speed;
- (b) type(s) of train;
- (c) train service requirements;
- (d) power demand of the trains at the pantographs.

4.2.2. *Basic parameters characterising the energy subsystem*

The basic parameters characterising the energy subsystem are:

4.2.2.1. Power supply:

- (a) Voltage and frequency (4.2.3);
- (b) Parameters relating to supply system performance (4.2.4);
- (c) Current capacity, DC systems, trains at standstill (4.2.5);
- (d) Regenerative braking (4.2.6);
- (e) Electrical protection coordination arrangements (4.2.7);
- (f) Harmonics and dynamic effects for AC traction power supply systems (4.2.8).

4.2.2.2. Geometry of the OCL and quality of current collection:

- (a) Geometry of the overhead contact line (4.2.9);
- (b) Pantograph gauge (4.2.10);
- (c) Mean contact force (4.2.11);
- (d) Dynamic behaviour and quality of current collection (4.2.12);
- (e) Pantograph spacing for overhead contact line design (4.2.13);
- (f) Contact wire material (4.2.14);
- (g) Phase separation sections (4.2.15);
- (h) System separation sections (4.2.16).

4.2.2.3. On-ground energy data collecting system (4.2.17)

4.2.2.4. Protective provisions against electric shock (4.2.18)

4.2.3. *Voltage and frequency*

- (1) The voltage and frequency of the energy subsystem shall be one of the four systems, specified in accordance with Section 7:
 - (a) AC 25 kV, 50 Hz;
 - (b) AC 15 kV, 16,7 Hz;
 - (c) DC 3 kV;
 - (d) DC 1,5 kV.
- (2) The values and limits of the voltage and frequency shall comply with EN 50163:2004, clause 4 for the selected system.

4.2.4. *Parameters relating to supply system performance*

The following parameters shall be taken in consideration:

- (a) maximum train current (4.2.4.1);
- (b) power factor of trains and the mean useful voltage (4.2.4.2).

4.2.4.1. Maximum train current

The energy subsystem design shall ensure the ability of the power supply to achieve the specified performance and allow the operation of trains with a power less than 2 MW without power or current limitation.

4.2.4.2. Mean useful voltage

The calculated mean useful voltage “at the pantograph” shall comply with EN 50388:2012, clause 8 (except clause 8.3 that is replaced by point C.1 of Appendix C). Simulation shall take into account values of the real power factor of trains. Point C.2 of Appendix C provides additional information to clause 8.2 of the EN 50388:2012.

4.2.5. *Current capacity, DC systems, trains at standstill*

- (1) The OCL of DC systems shall be designed to sustain 300 A (for a 1,5 kV supply system) and 200 A (for a 3 kV supply system), per pantograph when the train is at standstill.
- (2) The current capacity at standstill shall be achieved for the test value of static contact force given in table 4 of clause 7.2 of EN 50367:2012.
- (3) The OCL shall be designed taking into account the temperature limits in accordance with EN 50119:2009, clause 5.1.2.

4.2.6. *Regenerative braking*

- (1) AC power supply systems shall be designed to allow the use of regenerative braking able to exchange power seamlessly either with other trains or by any other means.
- (2) DC power supply systems shall be designed to permit the use of regenerative braking at least by exchanging power with other trains.

4.2.7. *Electrical protection coordination arrangements*

Electrical protection coordination design of the energy subsystem shall comply with the requirements detailed in EN 50388:2012, clause 11.

4.2.8. *Harmonics and dynamic effects for AC traction power supply systems*

- (1) The interaction of traction power supply system and rolling stock can lead to electrical instabilities in the system.
- (2) In order to achieve electrical system compatibility, harmonic overvoltages shall be limited below critical values according to EN 50388:2012, clause 10.4.

4.2.9. *Geometry of the overhead contact line*

- (1) The overhead contact line shall be designed for pantographs with the head geometry specified in the LOC & PAS TSI, point 4.2.8.2.9.2 taking into account the rules set out in point 7.2.3 of this TSI.
- (2) The contact wire height and the lateral deviation of the contact wire under the action of a cross-wind are factors which govern the interoperability of the rail network.

4.2.9.1. *Contact wire height*

- (1) The permissible data for contact wire height is given in Table 4.2.9.1.

Table 4.2.9.1

Contact wire height

Description	$v \geq 250$ [km/h]	$v < 250$ [km/h]
Nominal contact wire height [mm]	Between 5 080 and 5 300	Between 5 000 and 5 750
Minimum design contact wire height [mm]	5 080	In accordance with EN 50119:2009, clause 5.10.5 depending on the chosen gauge
Maximum design contact wire height [mm]	5 300	6 200 ⁽¹⁾

⁽¹⁾ Taking into account tolerances and uplift in accordance with EN 50119:2009 figure 1, the maximum contact wire height shall not be greater than 6 500 mm.

- (2) For the relation between the contact wire heights and pantograph working heights see EN 50119:2009 figure 1.
- (3) At level crossings the contact wire height shall be specified by national rules or in the absence of national rules, according to EN 50122-1:2011, clauses 5.2.4 and 5.2.5.
- (4) For the track gauge system 1 520 and 1 524 mm the values for contact wire height are as follows:
 - (a) Nominal contact wire height: between 6 000 mm and 6 300 mm;
 - (b) Minimum design contact wire height: 5 550 mm;
 - (c) Maximum design contact wire height: 6 800 mm.

4.2.9.2. Maximum lateral deviation

- (1) The maximum lateral deviation of the contact wire in relation to the track centre line under action of a cross wind shall be in accordance to table 4.2.9.2.

Table 4.2.9.2

Maximum lateral deviation depending on the pantograph length

Pantograph length [mm]	Maximum lateral deviation [mm]
1 600	400 ⁽¹⁾
1 950	550 ⁽¹⁾

⁽¹⁾ The values shall be adjusted taking into account the movement of the pantograph and track tolerances according to Appendix D.1.4.

- (2) In the case of the multi-rail track, the requirement for lateral deviation shall be fulfilled for each pair of rails (designed, to be operated as a separated track) that is intended to be assessed against TSI.
- (3) Track gauge system 1 520 mm:

For Member States applying the pantograph profile according to LOC&PAS TSI, point 4.2.8.2.9.2.3 the maximum lateral deviation of the contact wire in relation to the pantograph centre under action of a cross wind shall be 500 mm.

4.2.10. Pantograph gauge

- (1) No part of the energy sub-system shall enter the mechanical kinematic pantograph gauge (see Appendix D figure D.2) except for the contact wire and steady arm.
- (2) The mechanical kinematic pantograph gauge for interoperable lines is specified using the method shown in Appendix D.1.2 and the pantograph profiles defined in LOC&PAS TSI, points 4.2.8.2.9.2.1 and 4.2.8.2.9.2.2.
- (3) This gauge shall be calculated using a kinematic method, with values:
 - (a) for the pantograph sway e_{pu} of 0,110 m at the lower verification height $h'_u = 5,0$ m and
 - (b) for the pantograph sway e_{po} of 0,170 m at the upper verification height $h'_o = 6,5$ m,

in accordance with point D.1.2.1.4 of Appendix D and other values in accordance with point D.1.3 of Appendix D.

(4) Track gauge system 1 520 mm:

For Member States applying the pantograph profile according to LOC&PAS TSI, point 4.2.8.2.9.2.3 the static gauge available for pantograph is defined in point D.2 of Appendix D.

4.2.11. Mean contact force

- (1) The mean contact force F_m is the statistical mean value of the contact force. F_m is formed by the static, dynamic and aerodynamic components of the pantograph contact force.
- (2) The ranges of F_m for each of the power supply systems are defined in EN 50367:2012 Table 6.
- (3) The overhead contact lines shall be designed to be capable to sustain the upper design limit of F_m given in EN 50367:2012 Table 6.
- (4) The curves apply to speed up to 320 km/h. For speeds above 320 km/h procedures set out in point 6.1.3 shall apply.

4.2.12. Dynamic behaviour and quality of current collection

- (1) Depending on the assessment method, the overhead contact line shall achieve the values of dynamic performance and contact wire uplift (at the design speed) set out in Table 4.2.12.

Table 4.2.12

Requirements for dynamic behaviour and current collection quality

Requirement	$v \geq 250$ [km/h]	$250 > v > 160$ [km/h]	$v \leq 160$ [km/h]
Space for steady arm uplift	$2S_0$		
Mean contact force F_m	See 4.2.11		
Standard deviation at maximum line speed σ_{max} [N]	$0,3F_m$		
Percentage of arcing at maximum line speed, NQ [%] (minimum duration of arc 5 ms)	$\leq 0,2$	$\leq 0,1$ for AC systems $\leq 0,2$ for DC systems	$\leq 0,1$

- (2) S_0 is the calculated, simulated or measured uplift of the contact wire at a steady arm, generated in normal operating conditions with one or more pantographs with the upper limit of F_m at the maximum line speed. When the uplift of the steady arm is physically limited due to the overhead contact line design, it is permissible for the necessary space to be reduced to $1,5S_0$ (refer to EN 50119:2009, clause 5.10.2).
- (3) Maximum force (F_{max}) is usually within the range of F_m plus three standard deviations σ_{max} ; higher values may occur at particular locations and are given in EN 50119:2009, table 4, clause 5.2.5.2. For rigid components such as section insulators in overhead contact line systems, the contact force can increase up to a maximum of 350 N.

4.2.13. Pantograph spacing for overhead contact line design

The overhead contact line shall be designed for a minimum of two pantographs operating adjacently, in such a way that minimum spacing centre line to centre line of adjacent pantographs heads is equal or lower than values set out in one column "A", "B", or "C" selected from Table 4.2.13:

Table 4.2.13

Pantograph spacing for OCL design

Design speed [km/h]	AC Minimum distance [m]			3 kV DC Minimum distance [m]			1,5 kV DC Minimum distance [m]		
	A	B	C	A	B	C	A	B	C
$v \geq 250$	200			200			200	200	35
$160 < v < 250$	200	85	35	200	115	35	200	85	35
$120 < v \leq 160$	85	85	35	20	20	20	85	35	20
$80 < v \leq 120$	20	15	15	20	15	15	35	20	15
$v \leq 80$	8	8	8	8	8	8	20	8	8

4.2.14. *Contact wire material*

- (1) The combination of contact wire material and contact strip material has a strong impact on the wear of contact strips and contact wire.
- (2) Permissible contact strip materials are defined in point 4.2.8.2.9.4.2 of LOC&PAS TSI.
- (3) Permissible materials for contact wires are copper and copper-alloy. The contact wire shall comply with the requirements of EN 50149:2012, clauses 4.2, (excluding the reference to annex B of the standard) 4.3 and 4.6 to 4.8.

4.2.15. *Phase separation sections*4.2.15.1. *General*

- (1) The design of phase separation sections shall ensure that trains can move from one section to an adjacent one without bridging the two phases. Power consumption of the train (traction, auxiliaries and no-load current of the transformer) shall be brought to zero before entering the phase separation section. Adequate means (except for the short separation section) shall be provided to allow a train that is stopped within the phase separation section to be restarted.
- (2) The overall length D of neutral sections is defined in EN 50367:2012, clause 4. For the calculation of D clearances in accordance to EN 50119:2009, clause 5.1.3 and an uplift of S_0 shall be taken into account.

4.2.15.2. *Lines with speed $v \geq 250$ km/h*

Two types of designs of phase separation sections may be adopted, either:

- (a) a phase separation design where all the pantographs of the longest TSI compliant trains are within the neutral section. The overall length of the neutral section shall be at least 402 m.

For detailed requirements see EN 50367:2012, Annex A.1.2, or

- (b) a shorter phase separation with three insulated overlaps as shown in EN 50367:2012, Annex A.1.4. The overall length of the neutral section is less than 142 m including clearances and tolerances.

4.2.15.3. *Lines with speed $v < 250$ km/h*

The design of separation sections shall normally adopt solutions as described in EN 50367:2012, Annex A.1. Where an alternative solution is proposed, it shall be demonstrated that the alternative is at least as reliable.

4.2.16. System separation sections

4.2.16.1. General

- (1) The design of system separation sections shall ensure that trains can move from one power supply system to an adjacent different power supply system without bridging the two systems. There are two methods for traversing system separation sections:
 - (a) with pantograph raised and touching the contact wire;
 - (b) with pantograph lowered and not touching the contact wire.
- (2) The neighbouring Infrastructure Managers shall agree either (a) or (b) according to the prevailing circumstances.
- (3) The overall length D of neutral sections is defined in EN 50367:2012, clause 4. For the calculation of D clearances in accordance to EN 50119:2009, clause 5.1.3 and an uplift of S_0 shall be taken into account.

4.2.16.2. Pantographs raised

- (1) Power consumption of the train (traction, auxiliaries and no-load current of the transformer) shall be brought to zero before entering the system separation section.
- (2) If system separation sections are traversed with pantographs raised to the contact wire, their functional design is specified as follows:
 - (a) the geometry of different elements of the overhead contact line shall prevent pantographs short-circuiting or bridging both power systems;
 - (b) provision shall be made in the energy subsystem to avoid bridging of both adjacent power supply systems should the opening of the on-board circuit breaker(s) fail;
 - (c) variation in contact wire height along the entire separation section shall fulfil requirements set in EN 50119:2009, clause 5.10.3.

4.2.16.3. Pantographs lowered

- (1) This option shall be chosen if the conditions of operation with pantographs raised cannot be met.
- (2) If a system separation section is traversed with pantographs lowered, it shall be designed so as to avoid the electrical connection of the two power supply systems by an unintentionally raised pantograph.

4.2.17. On-ground energy data collecting system

- (1) Point 4.2.8.2.8 of LOC & PAS TSI contains the requirements for on-board Energy Measuring Systems (EMS) intended to produce and transmit the Compiled Energy Billing Data (CEBD) to an on-ground energy data collecting system.
- (2) The on-ground energy data collecting system (DCS) shall receive, store and export CEBD without corrupting it.
- (3) The specification related to interface protocols between EMS and DCS and transferred data format are an open point, which, in any case, shall be closed within 2 years after the entry into force of this Regulation.

4.2.18. Protective provisions against electric shock

Electrical safety of the overhead contact line system and protection against electric shock shall be achieved by compliance with EN 50122-1:2011+A1:2011, clauses 5.2.1 (only for public areas), 5.3.1, 5.3.2, 6.1, 6.2 (excluding requirements for connections for track circuits) and regarding AC voltage limits for the safety of persons by compliance with 9.2.2.1 and 9.2.2.2 of the standard and regarding DC voltage limits by compliance with 9.3.2.1 and 9.3.2.2 of the standard.

4.3. Functional and technical specifications of the interfaces

4.3.1. General requirements

From the standpoint of technical compatibility, the interfaces are listed in subsystem order as follows: rolling stock, infrastructure, control — command and signalling, and operation and traffic management.

4.3.2. Interface with Rolling Stock subsystem.

Reference in the ENE TSI		Reference in the LOC & PAS TSI	
Parameter	Point	Parameter	Point
Voltage and frequency	4.2.3	Operation within range of voltages and frequencies	4.2.8.2.2
Parameters relating to supply system performance: — max train current — power factor of trains and the mean useful voltage	4.2.4	Max current from OCL Power factor	4.2.8.2.4 4.2.8.2.6
Current capacity, DC systems, trains at standstill	4.2.5	Maximum current at standstill	4.2.8.2.5
Regenerative braking	4.2.6	Regenerative brake with energy to OCL	4.2.8.2.3
Electrical protection coordination arrangements	4.2.7	Electrical protection of the train	4.2.8.2.10
Harmonics and dynamic effects for AC traction power supply systems	4.2.8	System energy disturbances for AC systems	4.2.8.2.7
Geometry of the overhead contact line	4.2.9	Working range in height of pantograph Pantograph head geometry	4.2.8.2.9.1 4.2.8.2.9.2
Pantograph gauge	4.2.10 Appendix D	Pantograph head geometry Gauging	4.2.8.2.9.2 4.2.3.1
Mean contact force	4.2.11	Pantograph static contact force	4.2.8.2.9.5
		Pantograph contact force and dynamic behaviour	4.2.8.2.9.6
Dynamic behaviour and quality of current collection	4.2.12	Pantograph contact force and dynamic behaviour	4.2.8.2.9.6
Pantograph spacing for overhead contact line design	4.2.13	Arrangements of pantographs	4.2.8.2.9.7
Contact wire material	4.2.14	Contact strip material	4.2.8.2.9.4
Separation sections: phase system	4.2.15 4.2.16	Running through phase or system separation section	4.2.8.2.9.8
On-ground energy data collecting system	4.2.17	On-board Energy measurement system	4.2.8.2.8

4.3.3. *Interface with Infrastructure subsystem*

Reference in the ENE TSI		Reference in the INF TSI	
Parameter	Point	Parameter	Point
Pantographs gauge	4.2.10	Structure gauge	4.2.3.1

4.3.4. *Interface with Control — Command and Signalling subsystems*

- (1) The interface for power control is an interface between the energy and the rolling stock subsystems.
- (2) However, the information is transmitted via the control-command and signalling subsystems and consequently the transmission interface is specified in the CCS TSI and the LOC & PAS TSI.
- (3) The relevant information to perform the switching of the circuit breaker, change of maximum train current, change of the power supply system and pantograph management shall be transmitted via ERTMS when the line is equipped with ERTMS.
- (4) Harmonic currents affecting control-command and signalling subsystems are set out in the CCS TSI.

4.3.5. *Interface with Operation and traffic management subsystem*

Reference in the ENE TSI		Reference in the OPE TSI	
Parameter	Point	Parameter	Point
Maximum train current	4.2.4.1	Train composition	4.2.2.5
		Preparation of the Route Book	4.2.1.2.2.1
Separation sections: Phase System	4.2.15	Train composition	4.2.2.5
	4.2.16	Preparation of the Route Book	4.2.1.2.2.1

4.4. **Operating rules**

- (1) Operating rules are developed within the procedures described in the infrastructure manager safety management system. These rules take into account the documentation related to operation, which forms a part of the technical file, as required in Article 18(3) and as set out in Annex VI of Directive 2008/57/EC.
- (2) In certain situations involving pre-planned works, it may be necessary to temporarily derogate from the specifications of the energy subsystem and its interoperability constituents defined in Sections 4 and 5 of the TSI.

4.5. **Maintenance rules**

- (1) Maintenance rules are developed within the procedures described in the infrastructure manager safety management system.
- (2) The maintenance file for ICs and subsystem elements shall be prepared before placing a subsystem into service as the part of the technical file accompanying the declaration of verification.
- (3) The maintenance plan shall be drawn up for the subsystem to ensure that the requirements set out in this TSI are maintained during its lifetime.

4.6. Professional qualifications

The professional qualifications of staff required for the operation and maintenance of the energy subsystem are covered by the procedures described in the infrastructure manager safety management system and are not set out in this TSI.

4.7. Health and safety conditions

- (1) The health and safety conditions of staff required for the operation and maintenance of the energy subsystem shall be compliant with the relevant European and national legislation.
- (2) This issue is also covered by the procedures described in the infrastructure manager safety management system.

5. INTEROPERABILITY CONSTITUENTS

5.1. List of constituents

- (1) The interoperability constituents are covered by the relevant provisions of Directive 2008/57/EC and they are listed here below for the energy subsystem.
- (2) Overhead contact line:
 - (a) The interoperability constituent overhead contact line consists of the components listed below to be installed within an energy subsystem and the associated design and configuration rules.
 - (b) The components of an overhead contact line are an arrangement of wire(s) suspended over the railway line for supplying electricity to electric trains, together with associated fittings, in-line insulators and other attachments including feeders and jumpers. It is placed above the upper limit of the vehicle gauge, supplying vehicles with electrical energy through pantographs.
 - (c) The supporting components such as cantilevers, masts and foundations, return conductors, auto-transformer feeders, switches and other insulators are not part of the interoperability constituent overhead contact line. They are covered by subsystem requirements so far as interoperability is concerned.
- (3) The conformity assessment shall cover the phases and characteristics as indicated in point 6.1.4 and by X in the Table A.1 of Appendix A to this TSI.

5.2. Constituents' performances and specifications

5.2.1. Overhead contact line

5.2.1.1. Geometry of the OCL

The design of the overhead contact line shall comply with point 4.2.9.

5.2.1.2. Mean contact force

The overhead contact line shall be designed by using the mean contact force F_m stipulated in point 4.2.11.

5.2.1.3. Dynamic behaviour

Requirements for dynamic behaviour of the overhead contact line are set out in point 4.2.12.

5.2.1.4. Space for steady arm uplift

The overhead contact line shall be designed providing the required space for uplift as set out in point 4.2.12.

5.2.1.5. Pantograph spacing for overhead contact line design

The overhead contact line shall be designed for pantograph spacing as specified in point 4.2.13.

5.2.1.6. Current at standstill

For DC systems, the overhead contact line shall be designed for the requirements set out in point 4.2.5.

5.2.1.7. Contact wire material

The contact wire material shall comply with the requirements set out in point 4.2.14.

6. ASSESSMENT OF CONFORMITY OF THE INTEROPERABILITY CONSTITUENTS AND EC VERIFICATION OF THE SUBSYSTEMS

Modules for the procedures for assessment of conformity, suitability for use and EC verification modules are described in the Commission Decision 2010/713/EU.

6.1. **Interoperability constituents**6.1.1. *Conformity assessment procedures*

- (1) The conformity assessment procedures of interoperability constituents as defined in Section 5 of this TSI shall be carried out by application of relevant modules.
- (2) Assessment procedures for particular requirements for interoperability constituent are set out in point 6.1.4.

6.1.2. *Application of modules*

- (1) The following modules for conformity assessment of interoperability constituents are used:
 - (a) CA Internal production control
 - (b) CB EC type examination
 - (c) CC Conformity to type based on internal production control
 - (d) CH Conformity based on full quality management system
 - (e) CH1 Conformity based on full quality management system plus design examination

Table 6.1.2

Modules for conformity assessment to be applied for ICs

Procedures	Modules
Placed on the EU market before entry in force of this TSI	CA or CH
Placed on the EU market after entry in force of this TSI	CB + CC or CH1

- (2) The modules for conformity assessment of interoperability constituents shall be chosen from those shown in Table 6.1.2.
- (3) In the case of products placed on the market before the publication of relevant TSIs, the type is considered to have been approved and therefore EC type examination (module CB) is not necessary, provided that the manufacturer demonstrates that tests and verification of interoperability constituents have been considered successful for previous applications under comparable conditions and are in conformity with the requirements of this TSI. In this case these assessments shall remain valid in the new application. If it is not possible to demonstrate that the solution is positively proven in the past, the procedure for ICs placed on the EU market after publication of this TSI applies.

6.1.3. Innovative solutions for interoperability constituents

If an innovative solution is proposed for an interoperability constituent, the procedure described in Article 10 of this Regulation shall apply.

6.1.4. Particular assessment procedure for the interoperability constituent — overhead contact line

6.1.4.1. Assessment of dynamic behaviour and quality of current collection

(1) Methodology:

- (a) The assessment of the dynamic behaviour and the quality of the current collection involves the overhead contact line (energy subsystem) and the pantograph (rolling stock subsystem).
- (b) Compliance with the requirements on dynamic behaviour shall be verified by assessment of:
 - Contact wire uplift
 - and either:
 - Mean contact force F_m and standard deviation σ_{max}
 - or
 - Percentage of arcing
- (c) The Contracting Entity shall declare the method to be used for verification.
- (d) The design of overhead contact line shall be assessed with a simulation tool validated according with EN 50318:2002 and by measurement according to EN 50317:2012.
- (e) If an existing OCL design has been in operation for at least 20 years, then the requirement for simulation defined in the point (2) is optional. The measurement as defined in point (3) shall be carried out for the worst case arrangements of the pantographs regarding the interaction performance of this particular OCL design.
- (f) The measurement can be conducted on a specially constructed test section or on a line where the overhead contact line is under construction.

(2) Simulation:

- (a) For the purposes of simulation and analysis of the results, representative features (for example tunnels, crossovers, neutral sections etc.) shall be taken into account.
- (b) The simulations shall be made using at least two different TSI compliant types of pantograph for the appropriate speed ⁽¹⁾ and supply system, up to the design speed of the proposed interoperability constituent overhead contact line.
- (c) It is allowed to perform the simulation using types of pantograph that are under the process of IC certification, provided that they fulfil the other requirements of LOC&PAS TSI.
- (d) The simulation shall be performed for single pantograph and multiple pantographs with spacing according to the requirements set in point 4.2.13.
- (e) In order to be acceptable, the simulated current collection quality shall be in accordance with point 4.2.12 for uplift, mean contact force and standard deviation for each of the pantographs.

(3) Measurement:

- (a) If the simulation results are acceptable, a site dynamic test with a representative section of the new overhead contact line shall be undertaken.
- (b) This measurement can be done before putting into service or under full operation conditions.

⁽¹⁾ i.e. the speed of the two types of pantograph shall be at least equal to the design speed of the simulated overhead contact line.

- (c) For the above mentioned site test, one of the two types of the pantograph chosen for the simulation shall be installed on a rolling stock that allows the appropriate speed on the representative section.
- (d) The tests shall be performed at least for the worst case arrangements of the pantographs regarding the interaction performance derived from the simulations. If it is not possible to test using spacing between pantographs of 8 m, then it is permissible, for tests at speeds of up to 80 km/h, to increase the spacing between two consecutive pantographs to up to 15 m.
- (e) The mean contact force of each pantograph shall fulfil the requirements of the point 4.2.11 up to envisaged design speed of the OCL under test.
- (f) In order to be acceptable, the measured current collection quality shall be in accordance with point 4.2.12, for uplift, and either the mean contact force and standard deviation or percentage of arcing.
- (g) If all the above assessments are passed successfully, the tested overhead contact line design shall be considered to be compliant and may be used on lines where the characteristics of the design are compatible.
- (h) Assessment of dynamic behaviour and quality of current collection for interoperability constituent pantograph is set out in the point 6.1.3.7 of the LOC & PAS TSI.

6.1.4.2. Assessment of current at standstill

The conformity assessment shall be carried out in accordance with EN 50367:2012, Annex A.3 for the static force defined in point 4.2.5.

6.1.5. *EC declaration of conformity of interoperability constituent OCL*

According to Annex IV, Section 3 of Directive 2008/57/EC, the EC declaration of conformity shall be accompanied by statement setting out the condition of use:

- (a) maximum design speed;
- (b) nominal voltage and frequency;
- (c) nominal current rating;
- (d) accepted pantograph profile.

6.2. **Energy subsystem**

6.2.1. *General provisions*

- (1) At the request of the applicant, the notified body carries out EC verification in accordance with Article 18 of Directive 2008/57/EC and in accordance with the provisions of the relevant modules.
- (2) If the applicant demonstrates that tests or verifications of an energy subsystem have been successful for previous applications of a design in similar circumstances, the notified body shall take these tests and verifications into account for the EC verification.
- (3) Assessment procedures for particular requirements for subsystem are set out in point 6.2.4.
- (4) The applicant shall draw up the EC declaration of verification for the energy subsystem in accordance with Article 18(1) of and Annex V to Directive 2008/57/EC.

6.2.2. *Application of modules*

For the EC verification procedure of the energy subsystem, the applicant or its authorised representative established within the Community may choose either:

- (a) Module SG: EC verification based on unit verification, or
- (b) Module SH1: EC verification based on full quality management system plus design examination.

6.2.2.1. Application of module SG

In case of module SG, the notified body may take into account evidence of examinations, checking or tests that have been successfully performed under comparable conditions by other bodies or by (or on behalf of) the applicant.

6.2.2.2. Application of module SH1

The module SH1 may be chosen only where the activities contributing to the proposed subsystem to be verified (design, manufacturing, assembling, installation) are subject to a quality management system for design, production, final product inspection and testing, approved and surveyed by a notified body.

6.2.3. *Innovative solutions*

If an innovative solution is proposed for the energy subsystem, the procedure described in Article 10 of this Regulation shall apply.

6.2.4. *Particular assessment procedures for energy subsystem*

6.2.4.1. Assessment of mean useful voltage

- (1) The assessment shall be demonstrated in accordance with EN 50388:2012, clause 15.4.
- (2) The assessment shall be demonstrated only in the case of newly build or upgraded sub-systems.

6.2.4.2. Assessment of regenerative braking

- (1) The assessment for AC power supply fixed installations shall be demonstrated according to EN 50388:2012, clause 15.7.2.
- (2) The assessment for DC power supply shall be demonstrated by a design review.

6.2.4.3. Assessment of electrical protection coordination arrangements

The assessment shall be demonstrated for design and operation of substations in accordance with EN 50388:2012, clause 15.6.

6.2.4.4. Assessment of harmonics and dynamic effects for AC traction power supply systems

- (1) A compatibility study shall be carried out according to EN 50388:2012, clause 10.3.
- (2) This study shall be carried out only in the case of introducing converters with active semi-conductors in the power supply system.
- (3) The notified body shall assess if criteria of EN 50388:2012, clause 10.4 are fulfilled.

6.2.4.5. Assessment of dynamic behaviour and quality of current collection (integration into a subsystem)

- (1) The main goal of this test is to identify allocation design and construction errors but not to assess the basic design in principle.
- (2) Measurements of the interaction parameters shall be carried out in accordance with EN 50317:2012.
- (3) These measurements shall be carried out with an interoperability constituent pantograph, exhibiting the mean contact force characteristics as required by point 4.2.11 of this TSI for the design speed of the line considering aspects related to minimum speed and siding tracks.

- (4) The installed overhead contact line shall be accepted if the measurement results comply with the requirements in point 4.2.12.
- (5) For operational speeds up to 120 km/h (AC systems) and up to 160 km/h (DC systems), measurement of the dynamic behaviour is not mandatory. In this case alternative methods of identifying construction errors shall be used, such as measurement of OCL geometry according to point 4.2.9.
- (6) Assessment of dynamic behaviour and quality of current collection for integration of the pantograph into rolling stock subsystem are set out in point 6.2.3.20 of LOC & PAS TSI.

6.2.4.6. Assessment of the protective provisions against electric shock

- (1) For each installation it shall be demonstrated that the basic design of protective provisions against electric shock is in accordance with point 4.2.18.
- (2) In addition the existence of rules and procedures which ensure that the installation is installed as designed shall be checked.

6.2.4.7. Assessment of maintenance plan

- (1) The assessment shall be carried out by verifying the existence of the maintenance plan.
- (2) The notified body is not responsible for assessing the suitability of the detailed requirements set out in the plan.

6.3. **Sub-system containing interoperability constituents not holding an EC declaration**

6.3.1. *Conditions*

- (1) Until 31 May 2021, a notified body is allowed to issue an EC certificate of verification for a subsystem, even if some of the interoperability constituents incorporated within the subsystem are not covered by the relevant EC declarations of conformity and/or suitability for use according to this TSI, if the following criteria are complied with:
 - (a) the conformity of the subsystem has been checked against the requirements of Section 4 and in relation to points 6.2 and 6.3 and Section 7, except point 7.4, of this TSI by the notified body. Furthermore the conformity of the ICs to Section 5 and point 6.1 does not apply, and
 - (b) the interoperability constituents, which are not covered by the relevant EC declaration of conformity and/or suitability for use, have been used in a subsystem already approved and put in service in at least one of the Member State before the entry in force of this TSI.
- (2) EC Declarations of conformity and/or suitability for use shall not be drawn up for the interoperability constituents assessed in this manner.

6.3.2. *Documentation*

- (1) The EC certificate of verification of the subsystem shall indicate clearly which interoperability constituents have been assessed by the notified body as part of the subsystem verification.
- (2) The EC declaration of verification of the subsystem shall indicate clearly:
 - (a) which interoperability constituents have been assessed as part of the subsystem,
 - (b) confirmation that the subsystem contains the interoperability constituents identical to those verified as part of the subsystem,
 - (c) for those interoperability constituents, the reason(s) why the manufacturer did not provide an EC declaration of conformity and/or suitability for use before its incorporation into the subsystem, including the application of national rules notified under Article 17 of Directive 2008/57/EC.

6.3.3. *Maintenance of the subsystems certified according to 6.3.1*

- (1) During and after the transition period and until the subsystem is upgraded or renewed (taking into account the decision of Member State on application of TSIs), the interoperability constituents which do not hold an EC declaration of conformity and/or suitability for use and are of the same type are allowed to be used as maintenance related replacements (spare parts) for the subsystem, under the responsibility of the body responsible for maintenance.
- (2) In any case the body responsible for maintenance must ensure that the components for maintenance related replacements are suitable for their applications, are used within their area of use, and enable interoperability to be achieved within the rail system while at the same time meeting the essential requirements. Such components must be traceable and certified in accordance with any national or international rule, or any code of practice widely acknowledged in the railway domain.

7. IMPLEMENTATION OF THE ENERGY TSI

Member States shall develop a national plan for the implementation of this TSI, considering the coherence of the entire rail system of the European Union. This plan shall include all new, renewed and upgraded lines, in line with the details mentioned in points 7.1 to 7.4 here below.

7.1. **Application of this TSI to railway lines**

Sections 4 to 6 and any specific provisions in points 7.2 to 7.3 here below apply in full to the lines within the geographical scope of this TSI, which will be placed in service as interoperable lines after this TSI enters into force.

7.2. **Application of this TSI to new, renewed or upgraded railway lines**

7.2.1. *Introduction*

- (1) For the purpose of this section, a “new line” means a line that creates a route where none currently exists.
- (2) The following situations may be considered as an upgrade or renewal of existing lines:
 - (a) the realignment of part of an existing route;
 - (b) the creation of a bypass;
 - (c) the addition of one or more tracks on an existing route, regardless of the distance between the original tracks and the additional tracks.
- (3) In accordance with the conditions laid down in Article 20(1) of Directive 2008/57/EC, the implementation plan indicates the way existing fixed installations defined in point 2.1 shall be adapted when it is economically justified to do so.

7.2.2. *Implementation plan for voltage and frequency*

- (1) The choice of power supply system is a Member State's competence. The decision should be taken on economic and technical grounds, taking into account at least the following elements:
 - (a) the existing power supply system in the Member State;
 - (b) any connection to railway line in neighbouring countries with an existing electrical power supply;
 - (c) power demand.
- (2) New lines with speed greater than 250 km/h shall be supplied with one of the AC systems as defined in point 4.2.3.

7.2.3. *Implementation plan for OCL geometry*

7.2.3.1. *Scope of the implementation plan*

Member States' implementation plan shall take into account the following elements:

- (a) closing gaps between different OCL geometries;
- (b) any connection to the existing OCL geometries in neighbouring areas;
- (c) existing certified ICs OCL.

7.2.3.2. *Implementation rules for 1 435 mm track gauge system*

The OCL shall be designed taking into account the following rules:

- (a) New lines with speed greater than 250 km/h shall accommodate both pantographs as specified in the LOC & PAS TSI points 4.2.8.2.9.2.1 (1 600 mm) and 4.2.8.2.9.2.2 (1 950 mm).

If this is not possible, the OCL shall be designed for use by at least a pantograph with the head geometry specified in the LOC & PAS TSI point 4.2.8.2.9.2.1 (1 600 mm).

- (b) Renewed or upgraded lines with speed equal or greater than 250 km/h shall accommodate at least a pantograph with the head geometry specified in the LOC & PAS TSI point 4.2.8.2.9.2.1 (1 600 mm).
- (c) Other cases: the OCL shall be designed for use by at least one of the pantographs with the head geometry specified in the LOC & PAS TSI points 4.2.8.2.9.2.1 (1 600 mm) or 4.2.8.2.9.2.2 (1 950 mm).

7.2.3.3. *Track gauge systems different than 1 435mm*

The OCL shall be designed for use by at least one of the pantographs with the head geometry specified in the LOC & PAS TSI point 4.2.8.2.9.2.

7.2.4. *Implementation of the on-ground energy data collecting system*

Within 2 years after the "open point" mentioned in point 4.2.17 is closed, Member States shall ensure that an on-ground energy data collecting system capable to exchange compiled energy billing data will be implemented.

7.3. **Application of this TSI to existing lines**

7.3.1. *Introduction*

In case this TSI shall apply to existing lines and without prejudice to point 7.4 (specific cases), the following elements shall be considered:

- (a) Where Article 20(2) of Directive 2008/57/EC applies, Member States shall decide which requirements of the TSI shall apply, taking into account the implementation plan.
- (b) Where Article 20(2) of Directive 2008/57/EC does not apply, compliance with this TSI is recommended. Where compliance is not possible, the contracting entity informs the Member State of the reason thereof.
- (c) When a Member State requires a new authorisation for placing into service, the Contracting Entity shall define the practical measures and different phases of the project which are necessary to achieve the required levels of performance. These project phases may include transition periods for placing equipment into service with reduced levels of performance.

- (d) An existing subsystem may allow the circulation of TSI-compliant vehicles whilst meeting the essential requirements of Directive 2008/57/EC. The procedure to be used for the demonstration of the level of compliance with the basic parameters of the TSI shall be in accordance with Commission Recommendation 2011/622/EU ⁽¹⁾.

7.3.2. *Upgrading/renewal of the OCL and/or the power supply*

- (1) It is possible to gradually modify all or part of the OCL and/or the power supply system — element by element — over an extended period of time to achieve compliance with this TSI.
- (2) However, compliance of the entire subsystem can only be declared when all elements are compliant with the TSI over a complete section of route.
- (3) The process of upgrading/renewal should take into consideration the need of maintaining compatibility with the existing energy subsystem and other subsystems. For a project including elements not being TSI compliant, the procedures for the assessment of conformity and EC verification to be applied should be agreed with the Member State.

7.3.3. *Parameters related to maintenance*

While maintaining the energy subsystem, formal verifications and authorisations for placing into service are not required. However, maintenance replacements may be undertaken, as far as reasonably practicable, in accordance with the requirements of this TSI contributing to the development of interoperability.

7.3.4. *Existing subsystem that are not subject to a renewal or upgrading project*

The procedure to be used for the demonstration of the level of compliance of existing lines with the basic parameters of this TSI shall be in accordance with Commission Recommendation 2011/622/EU.

7.4. **Specific cases**

7.4.1. *General*

- (1) The specific cases, as listed in point 7.4.2, describe special provisions that are needed and authorised on particular networks of each Member State.
- (2) These specific cases are classified as:
 - “P” cases: “permanent” cases,
 - “T” cases: “temporary” cases, where it is planned that the target system is reached in the future.

7.4.2. *List of specific cases*

7.4.2.1. Particular features on the Estonian network

7.4.2.1.1. Voltage and frequency (4.2.3)

P case

Maximum allowed voltage of overhead contact line in Estonia is 4 kV (3 kV DC networks).

⁽¹⁾ Commission Recommendation 2011/622/EU of 20 September 2011 on the procedure demonstrating the level of compliance of existing railway lines with the basic parameters of the technical specifications for interoperability (OJ L 243, 21.9.2011, p. 23)

7.4.2.2. Particular features on the French network

7.4.2.2.1. Voltage and frequency (4.2.3)

T case

The values and limits of the voltage and frequency at the terminals of the substation and at the pantograph of the 1,5 kV DC electrified lines:

— Nimes to Port Bou,

— Toulouse to Narbonne,

may extend the values set out in EN50163:2004, clause 4 (U_{max2} close to 2 000 V).

7.4.2.2.2. Phase separation sections — lines with speed $v \geq 250$ km/h (4.2.15.2)

P case

In case of upgrading/renewal of high speed lines LN 1, 2, 3 and 4 special design of phase separation sections is allowed.

7.4.2.3. Particular features on the Italian network

7.4.2.3.1. Phase separation sections — lines with speed $v \geq 250$ km/h (4.2.15.2)

P case

In case of upgrading/renewal of high speed line Rome-Naples special design of phase separation sections is allowed.

7.4.2.4. Particular features on the Latvian network

7.4.2.4.1. Voltage and frequency (4.2.3)

P case

Maximum allowed voltage of overhead contact line in Latvia is 4 kV (3 kV DC networks).

7.4.2.5. Particular features on the Lithuanian network

7.4.2.5.1. Dynamic behaviour and quality of current collection (4.2.12)

P case

For existing overhead contact line designs the space for steady arm uplift is calculated according to national technical rules notified for this purpose.

7.4.2.6. Particular features on the Polish network

7.4.2.6.1. Electrical protection coordination arrangements (4.2.7)

P case

For Polish DC 3 kV network the note c in the table 7 of the standard EN 50388: 2012 is replaced by note: The tripping of the circuit breaker should be very rapid for high short-circuits currents. As far as possible, the traction unit circuit breaker should trip in order to try to avoid the substation circuit breaker tripping.

7.4.2.7. Particular features on the Spanish network

7.4.2.7.1. Contact wire height (4.2.9.1)

P case

On some sections of the future lines $v \geq 250$ km/h the nominal contact height is allowed 5,60 m.

7.4.2.7.2. Phase separation sections — lines with speed $v \geq 250$ km/h (4.2.15.2)

P case

In case of upgrading/renewal of existing high speed lines special design of phase separation sections shall be kept.

7.4.2.8. Particular features on the Swedish network

7.4.2.8.1. Assessment of mean useful voltage (6.2.4.1)

P case

Alternatively to assessment of mean useful voltage according to EN 50388:2012, clause 15.4, the power supply performance is also allowed to be assessed by:

- A comparison with a reference where the power supply solution has been used for a similar or more demanding train schedule. The reference shall have a similar or larger:
 - distance to the voltage controlled bus bar (frequency converter station),
 - impedance of the OCL system.
- A rough estimation of $U_{\text{mean useful}}$ for simple cases resulting in an increased additional capacity for future traffic demands.

7.4.2.9. Particular features on the UK network for Great Britain

7.4.2.9.1. Voltage and frequency (4.2.3)

P case

It is permissible to continue to upgrade, renew and extend networks equipped with the electrification system operating at 600/750 V DC and utilising conductor rails in a three and/or four rail configuration in accordance with the national technical rules notified for this purpose.

Specific case for the United Kingdom of Great Britain and Northern Ireland, applying only to the mainline network in Great Britain.

7.4.2.9.2. Contact wire height (4.2.9.1)

P case

For new, upgrade or renewal of the energy subsystem on existing infrastructure it is allowed to design the overhead contact line wire height in accordance with the national technical rules notified for this purpose.

Specific case for the United Kingdom of Great Britain and Northern Ireland, applying only to the mainline network in Great Britain.

7.4.2.9.3. Maximum lateral deviation (4.2.9.2) and pantograph gauge (4.2.10)

P case

For new, upgrade or renewal of the energy subsystem on existing infrastructure it is allowed to calculate the adjustment to the maximum lateral deviation, the verification heights, and pantograph gauge in accordance with the national technical rules notified for this purpose.

Specific case for the United Kingdom of Great Britain and Northern Ireland, applying only to the mainline network in Great Britain.

7.4.2.9.4. Protective provisions against electric shock (4.2.18)

P case

For upgrade or renewal of the existing energy subsystem or the construction of new energy subsystems on existing infrastructure, in place of the reference to EN50122-1:2011+A1:2011 clause 5.2.1, it is allowed to design the protective provisions against electric shock in accordance with the national technical rules notified for this purpose.

Specific case for the United Kingdom of Great Britain and Northern Ireland, applying only to the mainline network in Great Britain.

7.4.2.9.5. Conformity assessment of OCL as component

P case

The national rules may define the procedure for conformity related to points 7.4.2.9.2 and 7.4.2.9.3 and associated certificates.

The procedure may include the conformity assessment of parts which are not subject to a specific case.

7.4.2.10. Particular features on the Eurotunnel network

7.4.2.10.1. Contact wire height (4.2.9.1)

P case

For, upgrade or renewal of the existing energy subsystem it is allowed for the overhead contact line wire height to be designed in accordance with the technical rules notified for this purpose.

7.4.2.11. Particular features on the Luxembourgish network

7.4.2.11.1. Voltage and frequency (4.2.3)

T case

The values and limits of the voltage and frequency at the terminals of the substation and at the pantograph of the following 25 kV AC electrified lines between Bettembourg to Rodange (frontier) and the line section between Pétange and Leudelange may exceed the values set out in EN50163:2004, clause 4 ($U_{\max1}$ close to 30 kV and $U_{\max2}$ close to 30,5 kV).

Appendix A

Conformity assessment of interoperability constituents

A.1 SCOPE

This Appendix indicates the conformity assessment of interoperability constituent (overhead contact line) of the energy subsystem.

For existing interoperability constituents, the process described in point 6.1.2. shall be followed.

A.2 CHARACTERISTICS

The characteristics of the interoperability constituent to be assessed applying modules CB or CH1 are marked by an X in Table A.1. The production phase shall be assessed within the subsystem.

Table A.1

Assessment of the interoperability constituent: overhead contact line

Characteristic — point	Assessment in the following phase			
	Design and development phase			Production phase
	Design review	Manufacturing process review	Test ^(?)	Product quality (series production)
Geometry of the OCL — 5.2.1.1	X	N/A	N/A	N/A
Mean contact force — 5.2.1.2 ⁽¹⁾	X	N/A	N/A	N/A
Dynamic behaviour — 5.2.1.3	X	N/A	X	N/A
Space for steady arm uplift — 5.2.1.4	X	N/A	X	N/A
Pantograph spacing for overhead contact line design — 5.2.1.5	X	N/A	N/A	N/A
Current at standstill — 5.2.1.6	X	N/A	X	N/A
Contact wire material — 5.2.1.7	X	N/A	N/A	N/A

N/A: not applicable

⁽¹⁾ The measurement of the contact force is integrated with the process of assessment of dynamic behaviour and quality of current collection.

⁽²⁾ Test as defined in Section 6.1.4. on particular assessment procedure for the interoperability constituent — overhead contact line.

Appendix B

EC verification of the energy subsystem

B.1 SCOPE

This Appendix indicates the EC verification of the energy subsystem.

B.2 CHARACTERISTICS

The characteristics of the subsystem to be assessed in the different phases of design, installation and operation are marked by X in Table B.1.

Table B.1

EC verification of the energy subsystem

Basic parameters	Assessment phase			
	Design develop. phase	Production phase		
	Design review	Construction, assembly, mounting	Assembled, before putting into service	Validation under full operating conditions
Voltage and frequency — 4.2.3	X	N/A	N/A	N/A
Parameters relating to supply system performance — 4.2.4	X	N/A	N/A	N/A
Current capacity, DC systems, trains at standstill — 4.2.5	X ⁽¹⁾	N/A	N/A	N/A
Regenerative braking — 4.2.6	X	N/A	N/A	N/A
Electrical protection coordination arrangements — 4.2.7	X	N/A	X	N/A
Harmonics and dynamic effects for AC traction power supply systems-4.2.8	X	N/A	N/A	N/A
Geometry of the overhead contact line — 4.2.9	X ⁽¹⁾	N/A	N/A ⁽³⁾	N/A
Pantograph gauge — 4.2.10	X	N/A	N/A	N/A
Mean contact force — 4.2.11	X ⁽¹⁾	N/A	N/A	N/A
Dynamic behaviour and quality of current collection — 4.2.12	X ⁽¹⁾	N/A	X ⁽²⁾ ⁽³⁾	N/A ⁽²⁾
Pantograph spacing for overhead contact line design — 4.2.13	X ⁽¹⁾	N/A	N/A	N/A
Contact wire material — 4.2.14	X ⁽¹⁾	N/A	N/A	N/A
Phase separation sections — 4.2.15	X	N/A	N/A	N/A

Basic parameters	Assessment phase			
	Design develop. phase	Production phase		
	Design review	Construction, assembly, mounting	Assembled, before putting into service	Validation under full operating conditions
System separation sections — 4.2.16	X	N/A	N/A	N/A
On-ground energy data collecting system — 4.2.17	N/A	N/A	N/A	N/A
Protective provisions against electric shock — 4.2.18	X	X ⁽⁴⁾	X ⁽⁴⁾	N/A
Maintenance rules — 4.5	N/A	N/A	X	N/A

N/A: not applicable

- ⁽¹⁾ Only to be carried out if the overhead contact line has not been assessed as interoperability constituent.
- ⁽²⁾ Validation under full operating conditions shall only be done when the validation in the phase “Assembly before putting into service” is not possible.
- ⁽³⁾ To be carried out as an alternative assessment method in case the dynamic behaviour of the OCL integrated into subsystem is not measured (see point 6.2.4.5)
- ⁽⁴⁾ To be carried out in case the check is not done by another independent body.

Appendix C

Mean useful voltageC.1 VALUES FOR $U_{\text{MEAN USEFUL}}$ AT THE PANTOGRAPH

The minimum values for mean useful voltage at the pantograph under normal operating conditions shall be as given in Table C.1.

Table C.1

Minimum $U_{\text{mean useful}}$ at pantograph

Power supply system	V	
	Line speed $v > 200$ [km/h]	Line speed $v \leq 200$ [km/h]
	Zone and train	Zone and train
AC 25 kV 50 Hz	22 500	22 000
AC 15 kV 16,7 Hz	14 200	13 500
DC 3 kV	2 800	2 700
DC 1,5 kV	1 300	1 300

C.2 SIMULATION RULES

Zone used for simulation to calculate $U_{\text{mean useful}}$

- Simulations shall be carried out on a zone which represents a significant part of a line or a part of the network, such as the relevant feeding section(s) in the network for the object to be designed and assessed.

Time period used for simulation to calculate $U_{\text{mean useful}}$

- For simulation of $U_{\text{mean useful}}$ (train) and $U_{\text{mean useful}}$ (zone) only trains that are part of the simulation during a relevant time, such as the time needed to go through a complete feeding section, have to be considered.

Appendix D

Specification of the pantograph gauge

D.1 SPECIFICATION OF THE MECHANICAL KINEMATIC PANTOGRAPH GAUGE

D.1.1 **General**D.1.1.1 *Space to be cleared for electrified lines*

In the case of lines electrified by an overhead contact line, an additional space should be cleared:

- to accommodate the OCL equipment,
- to allow the free passage of the pantograph.

This Appendix deals with the free passage of the pantograph (pantograph gauge). The electrical clearance is considered by the Infrastructure Manager.

D.1.1.2 *Particularities*

The pantograph gauge differs in some aspects from the obstacle gauge:

- The pantograph is (partly) live and, for this reason, an electrical clearance is to be complied with, according to the nature of the obstacle (insulated or not),
- The presence of insulating horns should be taken into account, where necessary. Therefore a double reference contour has to be defined to take account of the mechanical and electrical interference simultaneously,
- In collecting condition, the pantograph is in permanent contact with the contact wire and, for this reason, its height is variable. So is the height of the pantograph gauge.

D.1.1.3 *Symbols and abbreviations*

Symbol	Designation	Unit
b_w	Half-length of the pantograph bow	m
$b_{w,c}$	Half-length of the pantograph bow conducting length (with insulating horns) or working length (with conducting horns)	m
$b'_{o,mec}$	Width of mechanical kinematic pantograph gauge at upper verification point	m
$b'_{u,mec}$	Width of mechanical kinematic pantograph gauge at lower verification point	m
$b'_{h,mec}$	Width of mechanical kinematic pantograph gauge at intermediate height, h	m
d_l	Lateral deviation of contact wire	m
D'_0	Reference cant taken into account by the vehicle for the pantograph gauge	m
e_p	Pantograph sway due to the vehicle characteristics	m
e_{po}	Pantograph sway at the upper verification point	m

Symbol	Designation	Unit
e_{pu}	Pantograph sway at the lower verification point	m
f_s	Margin to take account of the raising of the contact wire	m
f_{wa}	Margin to take account of the wear of the pantograph contact strip	m
f_{ws}	Margin to take account of the bow trespassing the contact wire due to the pantograph sway	m
h	Height in relation to the running surface	m
h'_{co}	Reference roll centre height for the pantograph gauge	m
h'	Reference height in the calculation of the pantograph gauge	m
h'_o	Maximum verification height of the pantograph gauge in a collecting position	m
h'_u	Minimum verification height of the pantograph gauge in a collecting position	m
h_{eff}	Effective height of the raised pantograph	m
h_{cc}	Static height of the contact wire	m
l'_o	Reference cant deficiency taken into account by the vehicle for the pantograph gauging	m
L	Distance between rail centres of a track	m
l	Track gauge, distance between the rail running edges	m
q	Transverse play between axle and bogie frame or, for vehicles not fitted with bogies, between axle and vehicle body	m
qs'	Quasi-static movement	m
R	Horizontal curve radius	m
s'_o	Flexibility coefficient taken into account by agreement between the vehicle and the infrastructure for the pantograph gauging	
$S'_{i/a}$	Allowed additional overthrow on the inside/outside of the curve for pantographs	m
w	Transverse play between bogie and body	m
S_j	Sum of the (horizontal) safety margins covering some random phenomena ($j = 1, 2$ or 3) for the pantograph gauge	m

Subscript a: refers to the outside of the curve

Subscript i: refers to the inside of the curve

D.1.1.4 Basic principles

Figure D.1

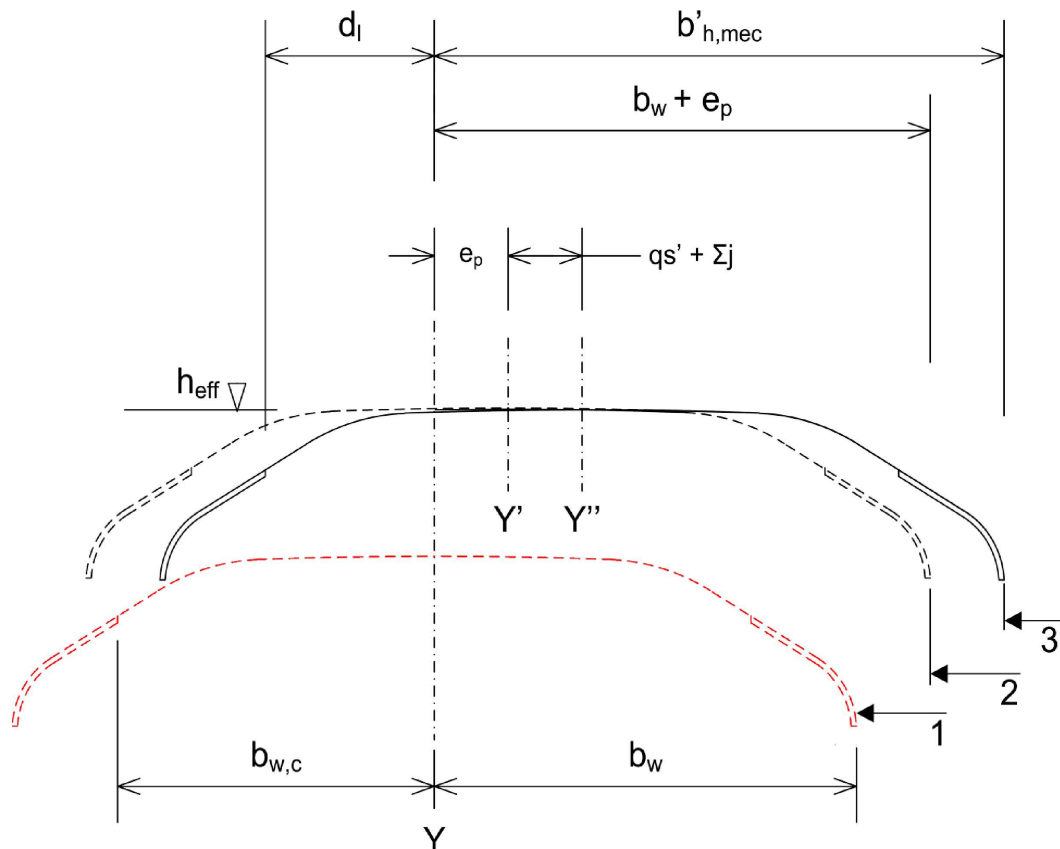
Pantograph mechanical gauges**Caption:**

Y: Centre line of the track

Y': Centre line of the pantograph — for deriving the free passage reference profile

Y'': Centre line of the pantograph — for deriving the mechanical kinematic pantograph gauge

1: Pantograph profile

2: Free passage reference profile

3: Mechanical kinematic gauge

The pantograph gauge is only met if the mechanical and electrical gauges are complied with simultaneously:

- The free passage reference profile includes the pantograph collector head length and the pantograph sway e_p , which applies up to the reference cant or cant deficiency,
- Live and insulated obstacles shall remain outside the mechanical gauge,
- Non insulated obstacles (earthed or at a potential different from the OCL) shall remain outside the mechanical and electrical gauges.

D.1.2 Specification of the mechanical kinematic pantograph gauge

D.1.2.1 Specification of the width of the mechanical gauge

D.1.2.1.1 Scope

The width of the pantograph gauge is mainly specified by the length and displacements of the pantograph under consideration. Beyond specific phenomena, phenomena similar to those of the obstacle gauge are found in the transverse displacements.

The pantograph gauge shall be considered at the following heights:

- The upper verification height h'_o
- The lower verification height h'_u

Between those two heights, it can be considered that gauge width varies in a linear way.

The various parameters are shown in figure D.2.

D.1.2.1.2 Calculation methodology

The pantograph gauge width shall be specified by the sum of the parameters defined below. In the case of a line run by various pantographs, the maximum width should be considered.

For the lower verification point with $h = h'_u$:

$$b'_{u(i/a),mec} = (b_w + e_{pu} + S'_{i/a} + qS'_{i/a} + \sum_j)_{max}$$

For the upper verification point with $h = h'_o$:

$$b'_{o(i/a),mec} = (b_w + e_{po} + S'_{i/a} + qS'_{i/a} + \sum_j)_{max}$$

NOTE i/a = inside/outside curve.

For any intermediate height h , width is specified by means of an interpolation:

$$b'_{h,mec} = b'_{u,mec} + \frac{h - h'_u}{h'_o - h'_u} \times (b'_{o,mec} - b'_{u,mec})$$

D.1.2.1.3 Half-length b_w of the pantograph bow

The half-length b_w of the pantograph bow depends on the type of pantograph used. The pantograph profile(s) to be considered are defined in LOC&PAS TSI, point 4.2.8.2.9.2.

D.1.2.1.4 Pantograph sway e_p

The sway mainly depends on the following phenomena:

- Play $q + w$ in the axle boxes and between bogie and body.
- The amount of body inclination taken into account by the vehicle (depending on the specific flexibility s'_o , the reference cant D'_o and the reference cant deficiency I'_o).

- The mounting tolerance of the pantograph on the roof.
- The transverse flexibility of the mounting device on the roof.
- The height under consideration h' .

Figure D.2

Specification of the width of the mechanical kinematic gauge of the pantograph at different heights

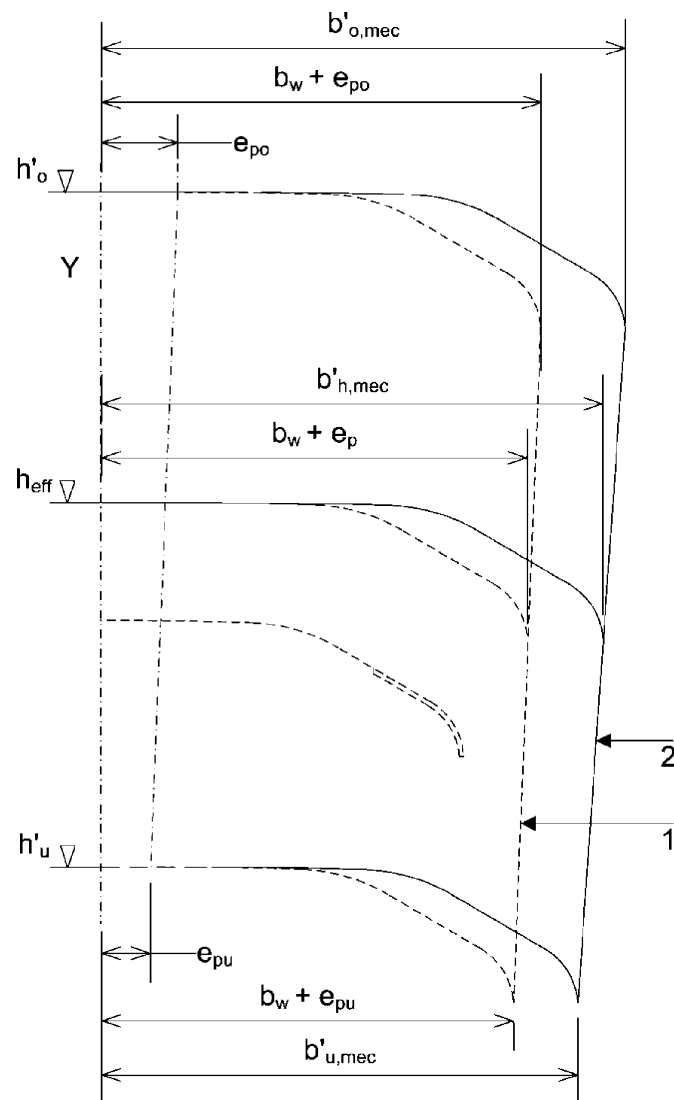

Caption:

- Y: Centre of the track
- 1: Free passage reference profile
- 2: Mechanical kinematic pantograph gauge

D.1.2.1.5 Additional overthrows

The pantograph gauge has a specific additional overthrows. In case of standard track gauge the following formula applies:

$$S'_{i/a} = \frac{2,5}{R} + \frac{\ell - 1,435}{2}$$

For other track gauges the national rules apply.

D.1.2.1.6 Quasi-static effect

Since the pantograph is installed on the roof, the quasi-static effect plays an important role in the calculation of the pantograph gauge. That effect is calculated from the specific flexibility s'_0 , reference cant D'_0 and reference cant deficiency I'_0 :

$$qs'_i = \frac{S'_0}{L} [D - D'_0]_{>0} (h - h'_{c0})$$

$$qs'_a = \frac{S'_0}{L} [I - I'_0]_{>0} (h - h'_{c0})$$

Note: Pantographs are normally mounted on the roof of a power unit, whose reference flexibility s'_0 is generally smaller than that of the obstacle gauge s_0 .

D.1.2.1.7 Allowances

According to gauge definition, the following phenomena should be considered:

- Loading dissymmetry;
- The transverse displacement of the track between two successive maintenance actions;
- The cant variation occurring between two successive maintenance actions;
- Oscillations generated by track unevenness.

The sum of the abovementioned allowances is covered by S_j .

D.1.2.2 Specification of the height of the mechanical gauge

Gauge height shall be specified on the basis of the static height h_{cc} , of the contact wire at the local point under consideration. The following parameters should be considered:

- The raising f_s of the contact wire generated by the pantograph contact force. The value of f_s depends on the OCL type and so shall be specified by the Infrastructure Manager in accordance with point 4.2.12.
- The raising of the pantograph head due to the pantograph head skew generated by the staggered contact point and the wear of the collector strip $f_{ws} + f_{wa}$. The permissible value of f_{ws} is shown in LOC & PAS TSI and f_{wa} depends on maintenance requirements.

The height of the mechanical gauge is given by the following formula:

$$h_{eff} = h_{cc} + f_s + f_{ws} + f_{wa}$$

D.1.3 Reference parameters

Parameters for the kinematic mechanical pantograph gauge and for Specification of the maximum lateral deviation of the contact wire shall be as follows:

- l — according to track gauge
- $s'_o = 0,225$
- $h'_{co} = 0,5$ m
- $l'_o = 0,066$ m and $D'_o = 0,066$ m
- $h'_o = 6,500$ m and $h'_u = 5,000$ m

D.1.4 Calculation of maximum lateral deviation of contact wire

The maximum lateral deviation of the contact wire shall be calculated by taking into consideration the total movement of the pantograph with respect to the nominal track position and the conducting range (or working length, for pantographs without horns made from a conducting material) as follows:

$$d_l = b_{w,c} + b_w + b'_{h,mec}$$

$b_{w,c}$ — defined in points 4.2.8.2.9.1 and 4.2.8.2.9.2 of LOC&PAS TSI

D.2 SPECIFICATION OF THE STATIC PANTOGRAPH GAUGE (TRACK GAUGE SYSTEM 1 520 mm)

This is applicable for Member States accepting the pantograph profile in accordance with LOC&PAS TSI point 4.2.8.2.9.2.3.

The pantograph gauge shall conform to Figure D.3 and Table D.1.

Figure D.3

Static pantograph gauge for 1 520mm track gauge system

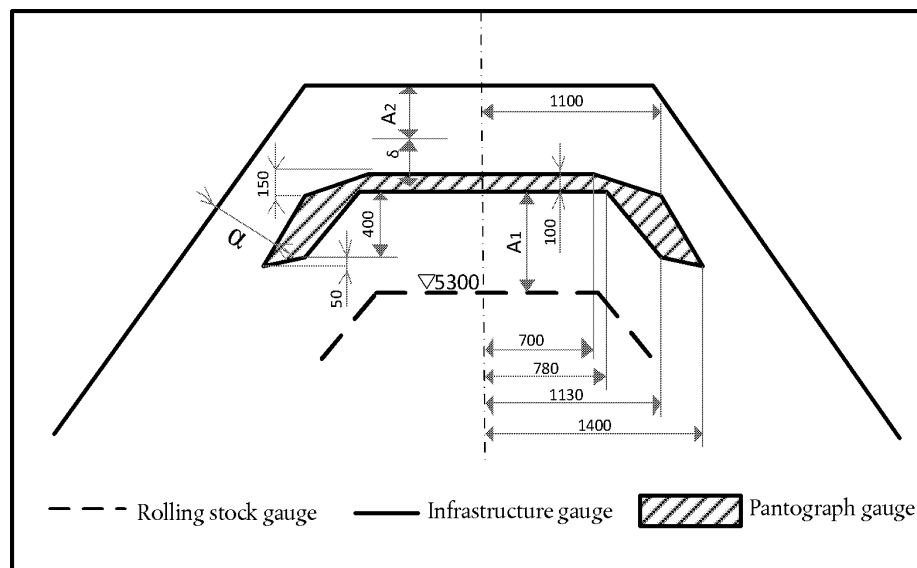

Table D.1

Distances between live parts of OCL and pantograph and earthed parts of rolling stock and fixed instalations for 1 520mm track gauge system

Voltage of the contact system in respect of the ground [kV]	Vertical air clearance A_1 between the rolling stock and lowest position of the contact wire [mm]			Vertical air clearance A_2 between live parts of OCL and earthed parts [mm]		Lateral air clearance α between live parts of the pantograph and earthed parts [mm]		Vertical space δ for the live parts of the OCL (mm)			
	Normal		Minimal allowed for plain and main station tracks on which train hoteling is not foreseen	Normal	Minimal allowed	Normal	Minimal allowed	Without catenary wire		With catenary wire	
	Plain and main station tracks on which train hoteling is not foreseen	Other station tracks						Normal	Minimal allowed	Normal	Minimal allowed
1	2	3	4	5	6	7	8	9	10	11	12
1,5-4	450	950	250	200	150	200	150	150	100	300	250
6-12	450	950	300	250	200	220	180	150	100	300	250
25	450	950	375	350	300	250	200	150	100	300	250

Appendix E

List of referenced standards

Table E.1

List of referenced standards

Index No.	Reference	Document name	Version	BP(s) concerned
1	EN 50119	Railway applications — Fixed installations — Electric traction overhead contact lines	2009	Current capacity, DC systems, trains at standstill (4.2.5), Geometry of overhead contact line (4.2.9), Dynamic behaviour and quality of current collection (4.2.12), Phase separation sections (4.2.15) and System separation sections (4.2.16)
2	EN 50122-1:2011 +A1:2011	Railway applications — Fixed installations — Electrical safety, earthing and the return circuit — Part 1: Protective provisions against electric shock	2011	Geometry of the overhead contact line (4.2.9) and Protective provisions against electric shock (4.2.18)
3	EN 50149	Railway applications — Fixed installations — Electric traction — Copper and copper alloy grooved contact wires	2012	Contact wire material (4.2.14)
4	EN 50163	Railway applications — Supply voltages of traction systems	2004	Voltage and frequency (4.2.3)
5	EN 50367	Railway applications — Current collection systems — Technical criteria for the interaction between pantograph and overhead line (to achieve free access)	2012	Current capacity, DC systems, trains at standstill (4.2.5), Mean contact force (4.2.11), Phase separation sections (4.2.15) and System separation sections (4.2.16)
6	EN 50388	Railway applications — Power supply and rolling stock — Technical criteria for the coordination between power supply (substation) and rolling stock to achieve interoperability	2012	Parameters relating to supply system performance (4.2.4), Electrical protection coordination arrangements (4.2.7), Harmonics and dynamic effects for AC systems (4.2.8)
7	EN 50317	Railway applications — Current collection systems — Requirements for and validation of measurements of the dynamic interaction between pantograph and overhead contact line	2012	Assessment of dynamic behaviour and quality of current collection (6.1.4.1 and 6.2.4.5)
8	EN 50318	Railway applications — Current collection systems — Validation of simulation of the dynamic interaction between pantograph and overhead contact line	2002	Assessment of dynamic behaviour and quality of current collection (6.1.4.1)

*Appendix F***List of open points**

- (1) Specification related to interface protocols between energy measuring system (EMS) and data collecting system (DCS) (4.2.17).

Appendix G

Glossary

Table G.1

Glossary

Defined term	Abbr.	Definition
AC		Alternative current
DC		Direct current
Compiled energy billing data	CEBD	Dataset compiled by the Data Handling System (DHS) suitable for energy billing
Contact line system		System that distributes the electrical energy to the trains running on the route and transmits it to the trains by means of current collectors
Contact force		Vertical force applied by the pantograph to the OCL
Contact wire uplift		Vertical upward movement of the contact wire due to the force produced from the pantograph
Current collector		Equipment fitted to the vehicle and intended to collect current from a contact wire or conductor rail
Gauge		Set of rules including a reference contour and its associated calculation rules allowing defining the outer dimensions of the vehicle and the space to be cleared by the infrastructure. NOTE: According to the calculation method implemented, the gauge will be a static, kinematic or dynamic
Lateral deviation		Lateral stagger of contact wire in maximum crosswind.
Level crossing		An intersection at the same elevation of a road and one or more rail tracks
Line speed		Maximum speed measured in kilometres per hour for which a line has been designed
Maintenance plan		A series of documents setting out the infrastructure maintenance procedures adopted by an infrastructure manager
Mean contact force		Statistical mean value of the contact force
Mean useful voltage train		Voltage identifying the dimensioning train and enables the effect on its performance to be quantified
Mean useful voltage zone		Voltage giving an indication of the quality of the power supply in a geographic zone during the peak traffic period in the timetable
Minimum contact wire height		A minimum value of the contact wire height in the span in order to avoid the arcing between one or more contact wires and vehicles in all conditions

Defined term	Abbr.	Definition
Neutral section insulator		An assembly inserted in a continuous run of contact line for isolating two electrical sections from each other that maintains continuous current collection during pantograph passage
Nominal contact wire height		A nominal value of the contact wire height at a support in the normal conditions
Nominal voltage		Voltage by which an installation or part of an installation is designated
Normal service		Planned timetable service
On-ground energy data collecting system (data collecting service)	DCS	On-ground service collecting the CEED from an Energy Measurement System
Overhead contact line	OCL	Contact line placed above (or beside) the upper limit of the vehicle gauge and supplying vehicles with electric energy through roof-mounted current collection equipment
Reference contour		A contour, associated to each gauge, showing the shape of a cross-section and used as a basis to work out the sizing rules of the infrastructure, on the one hand and of the vehicle, on the other hand
Return circuit		All conductors which form the intended path for the traction return current
Static contact force		Mean vertical force exerted upwards by the pantograph head on the OCL, and caused by the pantograph-raising device, whilst the pantograph is raised and the vehicle is standstill