

Official Journal

of the European Union

L 165

English edition

Legislation

Volume 51

26 June 2008

Contents

I Acts adopted under the EC Treaty/Euratom Treaty whose publication is obligatory

REGULATIONS

Commission Regulation (EC) No 600/2008 of 25 June 2008 establishing the standard import values for determining the entry price of certain fruit and vegetables	1
★ Commission Regulation (EC) No 601/2008 of 25 June 2008 on protective measures applying to certain fishery products imported from Gabon and intended for human consumption ⁽¹⁾	3
Commission Regulation (EC) No 602/2008 of 25 June 2008 on the allocation of import rights for applications lodged for the period 1 July 2008 to 30 June 2009 under the tariff quota opened by Regulation (EC) No 431/2008 for frozen meat of bovine animals	6
Commission Regulation (EC) No 603/2008 of 25 June 2008 on the allocation of import rights for applications lodged for the period 1 July 2008 to 30 June 2009 under tariff quotas opened by Regulation (EC) No 412/2008 for frozen beef intended for processing	7

II Acts adopted under the EC Treaty/Euratom Treaty whose publication is not obligatory

DECISIONS

Council

2008/486/EC:

- ★ **Council Decision of 23 June 2008 appointing half of the members of the Management Board of the European Food Safety Authority** 8

AGREEMENTS

Council

- ★ **Information on the date of entry into force of the Fisheries Partnership Agreement between the European Community and the Republic of Kiribati** 10

ACTS ADOPTED BY BODIES CREATED BY INTERNATIONAL AGREEMENTS

- ★ **Regulation No 12 of the Economic Commission for Europe of the United Nations (UN/ECE) — Uniform provisions concerning the approval of vehicles with regard to the protection of the driver against the steering mechanism in the event of impact** 11

III Acts adopted under the EU Treaty

ACTS ADOPTED UNDER TITLE V OF THE EU TREATY

- ★ **Council Joint Action 2008/487/CFSP of 23 June 2008 in support of the universalisation and implementation of the 1997 Convention on the Prohibition of the Use, Stockpiling, Production and Transfer of Anti-Personnel Mines and on their Destruction, in the framework of the European Security Strategy** 41

I

(Acts adopted under the EC Treaty/Euratom Treaty whose publication is obligatory)

REGULATIONS

COMMISSION REGULATION (EC) No 600/2008**of 25 June 2008****establishing the standard import values for determining the entry price of certain fruit and vegetables**

THE COMMISSION OF THE EUROPEAN COMMUNITIES,

Having regard to the Treaty establishing the European Community,

Having regard to Commission Regulation (EC) No 1580/2007 of 21 December 2007 laying down implementing rules of Council Regulations (EC) No 2200/96, (EC) No 2201/96 and (EC) No 1182/2007 in the fruit and vegetable sector ⁽¹⁾, and in particular Article 138(1) thereof,

Whereas:

- (1) Regulation (EC) No 1580/2007 lays down, pursuant to the outcome of the Uruguay Round multilateral trade negotiations, the criteria whereby the Commission fixes

the standard values for imports from third countries, in respect of the products and periods stipulated in the Annex thereto.

- (2) In compliance with the above criteria, the standard import values must be fixed at the levels set out in the Annex to this Regulation,

HAS ADOPTED THIS REGULATION:

Article 1

The standard import values referred to in Article 138 of Regulation (EC) No 1580/2007 shall be fixed as indicated in the Annex hereto.

Article 2

This Regulation shall enter into force on 26 June 2008.

This Regulation shall be binding in its entirety and directly applicable in all Member States.

Done at Brussels, 25 June 2008.

For the Commission

Jean-Luc DEMARTY

*Director-General for Agriculture and
Rural Development*

⁽¹⁾ OJ L 350, 31.12.2007, p. 1.

ANNEX

to Commission Regulation of 25 June 2008 establishing the standard import values for determining the entry price of certain fruit and vegetables

(EUR/100 kg)

CN code	Third country code ⁽¹⁾	Standard import value
0702 00 00	MA	60,9
	MK	34,1
	TR	59,6
	ZZ	51,5
0707 00 05	JO	156,8
	MK	22,9
	TR	83,4
	ZZ	87,7
0709 90 70	JO	216,7
	TR	100,0
	ZZ	158,4
0805 50 10	AR	103,2
	TR	135,6
	US	85,8
	ZA	154,5
	ZZ	119,8
0808 10 80	AR	87,3
	BR	79,0
	CL	90,0
	CN	73,8
	NZ	121,7
	US	94,9
	UY	88,3
	ZA	90,6
	ZZ	90,7
0809 10 00	IL	121,6
	TR	194,6
	ZZ	158,1
0809 20 95	TR	365,3
	US	353,8
	ZZ	359,6
0809 30 10, 0809 30 90	IL	144,8
	US	245,1
	ZZ	195,0
0809 40 05	IL	157,7
	TR	131,9
	ZZ	144,8

⁽¹⁾ Country nomenclature as fixed by Commission Regulation (EC) No 1833/2006 (OJ L 354, 14.12.2006, p. 19). Code 'ZZ' stands for 'of other origin'.

COMMISSION REGULATION (EC) No 601/2008

of 25 June 2008

on protective measures applying to certain fishery products imported from Gabon and intended for human consumption

(Text with EEA relevance)

THE COMMISSION OF THE EUROPEAN COMMUNITIES,

Having regard to the Treaty establishing the European Community,

Having regard to Regulation (EC) No 178/2002 of the European Parliament and of the Council of 28 January 2002 laying down the principles and requirements of food law, establishing the European Food Safety Authority and laying down procedures in matters of food safety⁽¹⁾, and in particular Article 53(1)(b) thereof,

Whereas:

(1) In accordance with Regulation (EC) No 178/2002, the necessary measures must be adopted where it is evident that food imported from a third country is likely to constitute a serious risk to human health, animal health or the environment and that such risk cannot be contained satisfactorily by means of measures taken by the Member State(s) concerned.

(2) A Community inspection carried out in Gabon in 2007 has revealed serious deficiencies with regard to certain fishery products intended to be exported to the European Community. Serious shortcomings were identified, in particular, regarding the capacity of the Gabonese authorities to take corrective action when high levels of heavy metals and sulphites occur.

(3) Commission Regulation (EC) No 1881/2006 of 19 December 2006 setting maximum levels for certain contaminants in foodstuffs⁽²⁾ lays down maximum levels of heavy metals for certain fishery products.

(4) European Parliament and Council Directive 95/2/EC of 20 February 1995 on food additives others than colours and sweeteners⁽³⁾ lays down maximum levels of sulphites in certain fishery products.

⁽¹⁾ OJ L 31, 1.2.2002, p. 1. Regulation as last amended by Commission Regulation (EC) No 202/2008 (OJ L 60, 5.3.2008, p. 17).

⁽²⁾ OJ L 364, 20.12.2006, p. 5. Regulation as amended by Regulation (EC) No 1126/2007 (OJ L 255, 29.9.2007, p. 14).

⁽³⁾ OJ L 61, 18.3.1995, p. 1. Directive as last amended by Directive 2006/52/EC (OJ L 204, 26.7.2006, p. 10).

(5) Member States should therefore carry out appropriate checks on certain fishery products from Gabon on arrival at the Community border to ensure compliance with Regulation (EC) No 1881/2006 and Directive 95/2/EC as regards heavy metals and sulphites, respectively.

(6) Member States shall use appropriate sampling plans and analytical methods for these checks. For sampling and analysis of heavy metals Commission Regulation (EC) No 333/2007⁽⁴⁾ shall apply.

(7) Regulation (EC) No 178/2002 sets up the Rapid Alert System for Food and Feed, which should be used to implement the mutual information requirement provided for in Article 22(2) of Council Directive 97/78/EC⁽⁵⁾. In addition the Member States will keep the Commission informed through periodical reports of all analytical results of official controls carried out in respect of consignments of those fishery products from Gabon, covered by this Regulation.

(8) The Regulation should be reviewed after one year in the light of the guarantees offered by the Gabonese competent authorities and on the basis of the results of the tests carried out by the Member States. A new Commission inspection may be necessary to verify the guarantees given.

(9) All expenditure incurred in the application of this Regulation shall be charged to the consignor, consignee or his agent.

(10) The measures provided for in this Regulation are in accordance with the opinion of the Standing Committee on the Food Chain and Animal Health,

⁽⁴⁾ OJ L 88, 29.3.2007, p. 29.

⁽⁵⁾ OJ L 24, 30.1.1998, p. 9. Directive as last amended by Directive 2006/104/EC (OJ L 363, 20.12.2006, p. 352).

HAS ADOPTED THIS REGULATION:

Article 1

This Regulation shall apply to those fishery products originating from Gabon and intended for human consumption which are covered by Commission Regulation (EC) No 1881/2006 as regards heavy metals and by European Parliament and Council Directive 95/2/EC as regards sulphites.

Article 2

1. Member States shall, by using appropriate sampling plans and analytical methods, ensure that each consignment of products covered by Article 1 undergoes necessary tests to make sure that the products concerned comply with the provisions laid down in Regulation (EC) No 1881/2006 as regards heavy metals and in Directive 95/2/EC as regards sulphites. For heavy metals sampling and analysis shall be carried out according to Regulation (EC) No 333/2007.

2. Member States shall submit to the Commission every three months a report of all analytical results of official controls on consignments of products covered by Article 1. This report shall be submitted during the month following each quarter (April, July, October and January).

3. The common reporting format, set out in the Annex to this Regulation shall be used.

Article 3

Member States shall not authorise imports of products as referred to in Article 1 that are found to be non-compliant with the provisions referred to in Article 2(1).

Article 4

All expenditure incurred in the application of this Regulation shall be charged to the consignor, consignee or the agent of either.

Article 5

This Regulation shall be reviewed in the light of the guarantees offered by the Gabonese competent authorities and on the basis of the results of the tests referred to in Article 2. A new Commission inspection may be necessary to verify the guarantees given.

Article 6

This Regulation shall enter into force on the seventh day following that of its publication in the *Official Journal of the European Union*.

This Regulation shall be binding in its entirety and directly applicable in all Member States.

Done at Brussels, 25 June 2008.

For the Commission
Androulla VASSILIOU
Member of the Commission

ANNEX

Common reporting format as referred to in Article 2.3**Results of controls on certain fishery products from gabon as regards heavy metals and sulphites**

Reporting country:

Year:

Quarter:

Type of fishery product	Sample code	Date of analysis (dd/mm/yyyy)	Substance analysed (e.g. Pb, Cd, Hg, sulphite) ⁽¹⁾	Result (mg/kg) ⁽²⁾	Measurement uncertainty (for heavy metals only) [x ± U] ⁽³⁾	Compliant (Yes/No)	Limit of detection (for heavy metals only) (mg/kg)	Limit of quantification (for heavy metals only) (mg/kg)

⁽¹⁾ Please report each analyte in a separate line.⁽²⁾ For sulphites the result shall be reported as SO₂.⁽³⁾ In accordance with Regulation (EC) No 333/2007.

COMMISSION REGULATION (EC) No 602/2008**of 25 June 2008****on the allocation of import rights for applications lodged for the period 1 July 2008 to 30 June 2009 under the tariff quota opened by Regulation (EC) No 431/2008 for frozen meat of bovine animals**

THE COMMISSION OF THE EUROPEAN COMMUNITIES,

Having regard to the Treaty establishing the European Community,

Having regard to Council Regulation (EC) No 1254/1999 of 17 May 1999 on the common organisation of the market in beef and veal ⁽¹⁾,

Having regard to Commission Regulation (EC) No 1301/2006 of 31 August 2006 laying down common rules for the administration of import tariff quotas for agricultural products managed by a system of import licences ⁽²⁾, and in particular Article 7(2) thereof,

Whereas:

- (1) Commission Regulation (EC) No 431/2008 of 19 May 2008 opening and providing for the administration of an import tariff quota for frozen meat of bovine animals

covered by CN code 0202 and products covered by CN code 0206 29 91 ⁽³⁾ opens an import tariff quota for beef and veal products.

- (2) The applications for import rights lodged for the period 1 July 2008 to 30 June 2009 relate to quantities exceeding those available. The extent to which import rights may be allocated should therefore be determined and an allocation coefficient laid down to be applied to the quantities applied for,

HAS ADOPTED THIS REGULATION:

Article 1

The quantities for which import right applications covered by the quota with the serial number 09.4003 have been lodged for the period 1 July 2008 to 30 June 2009 under Regulation (EC) No 431/2008 shall be multiplied by an allocation coefficient of 20,564162 %.

Article 2

This Regulation shall enter into force on 26 June 2008.

This Regulation shall be binding in its entirety and directly applicable in all Member States.

Done at Brussels, 25 June 2008.

For the Commission

Jean-Luc DEMARTY

*Director-General for Agriculture and
Rural Development*

⁽¹⁾ OJ L 160, 26.6.1999, p. 21. Regulation as last amended by Regulation (EC) No 1913/2005 (OJ L 307, 25.11.2005, p. 2). Regulation (EC) No 1254/1999 will be replaced by Regulation (EC) No 1234/2007 (OJ L 299, 16.11.2007, p. 1) as from 1 July 2008.

⁽²⁾ OJ L 238, 1.9.2006, p. 13. Regulation as amended by Regulation (EC) No 289/2007 (OJ L 78, 17.3.2007, p. 17).

⁽³⁾ OJ L 130, 20.5.2007, p. 3.

COMMISSION REGULATION (EC) No 603/2008**of 25 June 2008****on the allocation of import rights for applications lodged for the period 1 July 2008 to 30 June 2009 under tariff quotas opened by Regulation (EC) No 412/2008 for frozen beef intended for processing**

THE COMMISSION OF THE EUROPEAN COMMUNITIES,

Having regard to the Treaty establishing the European Community,

Having regard to Council Regulation (EC) No 1254/1999 of 17 May 1999 on the common organisation of the market in beef and veal ⁽¹⁾,

Having regard to Commission Regulation (EC) No 1301/2006 of 31 August 2006 laying down common rules for the administration of import tariff quotas for agricultural products managed by a system of import licences ⁽²⁾ and in particular Article 7(2) thereof,

Whereas:

- (1) Commission Regulation (EC) No 412/2008 of 8 May 2008 opening and providing for the administration of an import tariff quota for frozen beef intended for processing ⁽³⁾ opened import tariff quotas for beef and veal products.

- (2) The applications for import rights lodged for the period 1 July 2008 to 30 June 2009 relate to quantities in excess of those available for rights under quota 09.4057. The extent to which import rights may be granted should therefore be determined and the allocation coefficient to be applied to the quantities requested should be laid down,

HAS ADOPTED THIS REGULATION:

Article 1

Applications for import rights lodged for the period 1 July 2008 to 30 June 2009 under Regulation (EC) No 412/2008 shall be weighted by an allocation coefficient of 9,748767 % for rights under quota 09.4057.

Article 2

This Regulation shall enter into force on 26 June 2008.

This Regulation shall be binding in its entirety and directly applicable in all Member States.

Done at Brussels, 25 June 2008.

For the Commission

Jean-Luc DEMARTY

*Director-General for Agriculture and
Rural Development*

⁽¹⁾ OJ L 160, 26.6.1999, p. 21. Regulation as last amended by Regulation (EC) No 1913/2005 (OJ L 307, 25.11.2005, p. 2). Regulation (EC) No 1254/1999 will be replaced by Regulation (EC) No 1234/2007 (OJ L 299, 16.11.2007, p. 1) as from 1 July 2008.

⁽²⁾ OJ L 238, 1.9.2006, p. 13. Regulation as amended by Regulation (EC) No 289/2007 (OJ L 78, 17.3.2007, p. 17).

⁽³⁾ OJ L 125, 9.5.2008, p. 7.

II

(Acts adopted under the EC Treaty/Euratom Treaty whose publication is not obligatory)

DECISIONS

COUNCIL

COUNCIL DECISION

of 23 June 2008

appointing half of the members of the Management Board of the European Food Safety Authority

(2008/486/EC)

THE COUNCIL OF THE EUROPEAN UNION,

Having regard to the Treaty establishing the European Community,

Having regard to Regulation (EC) No 178/2002 of the European Parliament and of the Council of 28 January 2002 laying down the general principles and requirements of food law, establishing the European Food Safety Authority and laying down procedures in matters of food safety⁽¹⁾, and in particular Article 25(1) thereof,

Having regard to the list of candidates submitted to the Council by the Commission of the European Communities,

Having regard to the views expressed by the European Parliament,

Whereas:

- (1) It is vital to ensure the independence, high scientific quality, transparency and efficiency of the European Food Safety Authority. Cooperation with Member States is also indispensable.
- (2) Half of the members of the Management Board of the Authority will finish their term of office on 30 June 2008.
- (3) The candidatures have been examined with a view to appointing seven new members of the Management Board on the basis of the documentation provided by the Commission and in the light of the views

expressed by the European Parliament. The aim is to secure the highest standard of competence, a broad range of relevant expertise, for instance in management and in public administration, and the broadest possible geographic distribution within the Union.

- (4) Three of those members should have a background in organisations representing consumers and other interests in the food chain,

HAS DECIDED AS FOLLOWS:

Article 1

The following shall be appointed members of the Management Board of the European Food Safety Authority for the period from 1 July 2008 to 30 June 2012:

- Davies, Sue (*)
- Facelli, Piergiuseppe
- Horst, Matthias (*)
- Pogačnik, Milan
- Ruprich, Jiri
- Turunen, Sinikka (*)
- Url, Bernhard.

⁽¹⁾ OJ L 31, 1.2.2002, p. 1. Regulation as last amended by Commission Regulation (EC) No 202/2008 (OJ L 60, 5.3.2008, p. 17).

(*) Background in organisations representing consumers and other interests in the food chain.

Article 2

This Decision shall be published in the *Official Journal of the European Union*.

Done at Luxembourg, 23 June 2008.

For the Council
The President
I. JARC

AGREEMENTS

COUNCIL

Information on the date of entry into force of the Fisheries Partnership Agreement between the European Community and the Republic of Kiribati

On 15 November 2007 and 29 April 2008 respectively, the European Community and the Government of the Republic of Kiribati notified each other that the procedures necessary for entry into force of the Agreement had been completed ⁽¹⁾.

The Agreement accordingly entered into force on 29 April 2008, in accordance with Article 18 thereof.

⁽¹⁾ OJ L 205, 7.8.2007, p. 3.

ACTS ADOPTED BY BODIES CREATED BY INTERNATIONAL AGREEMENTS

Only the original UN/ECE texts have legal effect under international public law. The status and date of entry into force of this Regulation should be checked in the latest version of the UN/ECE status document TRANS/WP.29/343, available at:
<http://www.unece.org/trans/main/wp29/wp29wgs/wp29gen/wp29fdocsts.html>

Regulation No 12 of the Economic Commission for Europe of the United Nations (UN/ECE) — Uniform provisions concerning the approval of vehicles with regard to the protection of the driver against the steering mechanism in the event of impact

Incorporating all valid text up to:

Supplement 3 to the 03 series of amendments — Date of entry into force: 23 March 2000

1. SCOPE

- 1.1. This Regulation applies to the behaviour of the steering mechanism of motor vehicles of category M₁, and vehicles of category N₁, with a maximum permissible mass less than 1 500 kg, with regard to the protection of the driver in a frontal collision.
- 1.2. At the request of a manufacturer, vehicles other than those mentioned in paragraph 1.1 above may be approved under this Regulation.

2. DEFINITIONS

For the purposes of this Regulation,

- 2.1. '*approval of a vehicle*' means the approval of a vehicle type with regard to the protection of the driver against the steering mechanism in the event of impact;
- 2.2. '*vehicle type*' means a category of motor vehicles which do not differ in such essential respects as:
- 2.2.1. Vehicle powered by an internal combustion engine:
- 2.2.1.1. the structure, dimensions, lines and constituent materials of that part of the vehicle forward of the steering control;
- 2.2.1.2. the mass of vehicle in running order, as defined in paragraph 2.18 below;
- 2.2.2. Vehicle powered by an electric motor:
- 2.2.2.1. Dimensions, mass, structure of the vehicle, forms and constituent materials, place of the components of the propulsion system, place of the battery or of the parts of propulsion battery.
- 2.2.2.2. Mass of the vehicle in running order, as defined in paragraph 2.18 below.
- 2.3. '*approval of a steering control*' means the approval of a steering control type with regard to the protection of the driver against the steering mechanism in the event of impact;

- 2.4. '*steering control type*' means a category of steering controls which do not differ in such essential respects as:
- 2.4.1. the structure, dimensions, lines and constituent materials;
- 2.5. '*steering control*' means the steering device, usually the steering wheel, which is actuated by the driver;
- 2.6. '*general steering control*' means a steering control which can be fitted to more than one approved vehicle type where differences in the attachment of the steering control to the steering column do not affect the impact performance of the steering control;
- 2.7. '*Air-bag*' means a flexible bag that is designed to be filled with a gas under pressure, and is:
- 2.7.1. designed to protect the vehicle driver in an impact against the steering control;
- 2.7.2. inflated by a device which is actuated in case of vehicle's impact;
- 2.8. '*Steering control rim*' means the quasi-toroidal outer ring in the case of the steering wheel usually gripped by the driver's hands during driving;
- 2.9. '*Spoke*' means a bar connecting the steering control rim to the boss;
- 2.10. '*Boss*' means that part of the steering control, usually at the centre, that:
- 2.10.1. joins the steering control to the steering shaft,
- 2.10.2. transmits the torque from the steering control to the steering shaft;
- 2.11. '*Centre of the steering control boss*' means that point on the surface of the boss which is in line with the axis of the steering shaft;
- 2.12. '*Plane of the steering control*' means in the case of the steering wheel the flat surface that splits the steering wheel rim equally between the driver and the front of the car;
- 2.13. '*steering shaft*' means the component which transmits to the steering gear the torque applied to the steering control;
- 2.14. '*steering column*' means the housing enclosing the steering shaft;
- 2.15. '*steering mechanism*' means the aggregate comprising the steering control, the steering column, the assembly accessories, the steering shaft, the steering gear housing, and all other components such as those designed to contribute to the absorption of energy in the event of impact against the steering control;
- 2.16. '*passenger compartment*' means the space for occupant accommodation, bounded by the roof, floor, side walls, doors, outside glazing, front bulkhead, and the plane of the rear compartment bulkhead or the plane of the rear seat back support, and if necessary any partition of the tray(s) containing the monoblocs of the electric vehicle's propulsion battery;
- 2.17. '*Impactor*' consists of a rigid hemispherical headform 165 mm in diameter, in accordance with Annex 5, paragraph 3 of this Regulation;

- 2.18. '*Mass of the vehicle in running order*' means the mass of the vehicle unoccupied and unladen but complete with fuel, coolant, lubricant tools and spare wheel, if provided as standard equipment by the vehicle manufacturer, and propulsion battery tray(s) including the monoblocs of the electric vehicle's propulsion battery.
- 2.19. '*Monobloc*' means the smallest unit of the propulsion electric energy source;
- 2.20. '*Propulsion battery*' means the assembly of the blocs constituting the electric energy source;
- 2.21. '*Propulsion battery tray*' means the tray containing one or more monoblocs; a vehicle can comprise no tray or one or more trays;

3. APPLICATION FOR APPROVAL

3.1. **Vehicle type**

- 3.1.1. The application for approval of a vehicle type with regard to the protection of the driver against the steering mechanism in the event of impact shall be submitted by the vehicle manufacturer or by his duly accredited representative.
- 3.1.2. It shall be accompanied by the undermentioned documents in triplicate and the following particulars:
 - 3.1.2.1. a detailed description of the vehicle type with respect to the structure, dimensions, lines and constituent materials of that part of the vehicle forward of the steering control;
 - 3.1.2.2. drawings, on an appropriate scale and in sufficient detail, of the steering mechanism and of its attachment to the vehicle chassis and body;
 - 3.1.2.3. a technical description of that mechanism;
 - 3.1.2.4. an indication of the mass of the vehicle in running order;
 - 3.1.2.5. evidence that the steering control has been approved in accordance with paragraph 5.2 of the Regulation, if applicable.
 - 3.1.2.6. evidence that the steering mechanism complies with the specifications of paragraph 5.2.2 of Regulation No 94, 01 series of amendments, if the application for approval is submitted by the applicant pursuant paragraph 5.1.2 below.
 - 3.1.2.7. evidence that the steering control complies with the specifications of paragraphs 5.2.1.4 and 5.2.1.5 of Regulation No 94, 01 series of amendments if the application for approval is submitted by the applicant pursuant paragraph 5.2.1 below.
- 3.1.3. The following shall be submitted to the technical service responsible for conducting approval tests:
 - 3.1.3.1. a vehicle, representative of the vehicle type to be approved, for the test referred to in paragraph 5.1 below;
 - 3.1.3.2. at the manufacturer's discretion, with the agreement of the technical service, either a second vehicle, or those parts of the vehicle regarded by him as essential for the test referred to in paragraphs 5.2 and 5.3 below.
 - 3.1.3.3. The competent authority shall verify the existence of satisfactory arrangements for ensuring effective control of the conformity of production before type approval is granted.

3.2. **Steering control type**

- 3.2.1. The application for approval of a steering control type with regard to the protection of the driver against the steering mechanism in the event of an impact shall be submitted by the steering control manufacturer or by his duly accredited representative.
- 3.2.2. It shall be accompanied by the undermentioned documents in triplicate and the following particulars:
- 3.2.2.1. a detailed description of the steering control type with respect to the structure, the dimensions and the constituent materials of the steering control;
- 3.2.2.2. drawings, on an appropriate scale and in sufficient detail, of the steering mechanism and of its attachment to the vehicle chassis and body.
- 3.2.2.3. evidence that the steering control complies with the specifications of paragraphs 5.2.1.4 and 5.2.1.5 of Regulation No 94, 01 series of amendments, if the application for approval is submitted by the applicant pursuant paragraph 5.2.1 below.
- 3.2.3. A steering control representative of the steering control type to be approved plus, at the manufacturer's discretion, with the agreement of the technical service, those parts of the vehicle regarded by him as essential for the test, shall be submitted to the technical service responsible for conducting approval tests for the test referred to in paragraphs 5.2 and 5.3 below.

4. APPROVAL

- 4.1. A certificate conforming to the model specified in paragraphs 4.1.1 or 4.1.2 shall be attached to the type-approval certificate:
- 4.1.1. Annex 1A for applications referred to in paragraph 3.1;
- 4.1.2. Annex 1B for applications referred to in paragraph 3.2.

4.2. **Vehicle type**

- 4.2.1. If the vehicle submitted for approval pursuant to this Regulation meets the requirements of paragraphs 5 and 6 below and Annexes 4, 5 and 6 to this Regulation, approval of that vehicle type shall be granted.
- 4.2.2. An approval number shall be assigned to each type approved. Its first two digits (at present 03 corresponding to the 03 series of amendments, entered into force on 24 August 1993) shall indicate the series of amendments incorporating the most recent major technical amendments made to the Regulation at the time of issue of the approval. The same Contracting Party shall not assign the same number to the same vehicle type equipped with another type of steering mechanism, or to another vehicle type, as defined in paragraph 2.2 above.
- 4.2.3. Notice of approval or of extension or refusal of approval of a vehicle type pursuant to this Regulation shall be communicated to the Parties to the Agreement applying this Regulation, by means of a form conforming to the model in Annex 1A to this Regulation.

- 4.2.4. There shall be affixed, conspicuously and in a readily accessible place specified on the approval form, to every vehicle conforming to a vehicle type approved under this Regulation an international approval mark consisting of:
- 4.2.4.1. a circle surrounding the letter 'E' followed by the distinguishing number of the country which has granted approval ⁽¹⁾;
- 4.2.4.2. the number of this Regulation, followed by the letter 'R', a dash and the approval number to the right of the circle prescribed in paragraph 4.2.4.1.
- 4.2.5. If the vehicle conforms to a vehicle type approved, under one or more other Regulations annexed to the Agreement, in the country which has granted approval under this Regulation, the symbol prescribed in paragraph 4.2.4.1 need not be repeated; in such a case the Regulation and approval numbers and the additional symbols of all the Regulations under which approval has been granted in the country which has granted approval under this Regulation shall be placed in vertical columns to the right of the symbol prescribed in paragraph 4.2.4.1.
- 4.2.6. The approval mark shall be clearly legible and be indelible.
- 4.2.7. The approval mark shall be placed close to or on the vehicle data plate affixed by the manufacturer.
- 4.3. **Steering-control type**
- 4.3.1. If the steering control submitted for separate approval pursuant to this Regulation meets the applicable requirements of paragraphs 5 and 6 below and Annexes 4, 5 and 6 to this Regulation, approval of that steering control type shall be granted. This is only applicable to steering controls which do not include an airbag.
- 4.3.2. An approval number shall be assigned to each type approved. Its first two digits (at present 03 corresponding to the 03 series of amendments, entered into force on 24 August 1993) shall indicate the series of amendments incorporating the most recent major technical amendments made to the Regulation at the time of issue of the approval. The same Contracting Party shall not assign the same number to another steering control type as defined in paragraph 2.4 above.
- 4.3.3. Notice of approval or of extension or refusal of approval of a steering control type pursuant to this Regulation shall be communicated to the Parties to the Agreement applying this Regulation, by means of a form conforming to the model in Annex 1B to this Regulation.
- 4.3.4. There shall be affixed, conspicuously and in a readily accessible place specified on the approval form, to every steering control conforming to a steering control type approved under this Regulation an international approval mark consisting of:
- 4.3.4.1. a circle surrounding the letter 'E' followed by the distinguishing number of the country which has granted approval ⁽²⁾;

⁽¹⁾ 1 for Germany, 2 for France, 3 for Italy, 4 for the Netherlands, 5 for Sweden, 6 for Belgium, 7 for Hungary, 8 for the Czech Republic, 9 for Spain, 10 for Yugoslavia, 11 for the United Kingdom, 12 for Austria, 13 for Luxembourg, 14 for Switzerland, 15 (vacant), 16 for Norway, 17 for Finland, 18 for Denmark, 19 for Romania, 20 for Poland, 21 for Portugal, 22 for the Russian Federation, 23 for Greece, 24 for Ireland, 25 for Croatia, 26 for Slovenia and 27 for Slovakia, 28 for Belarus, 29 for Estonia, 30 (vacant), 31 for Bosnia and Herzegovina, 32 for Latvia, 33 (vacant), 34 for Bulgaria, 35-36 (vacant), 37 for Turkey, 38-39 (vacant), 40 for The former Yugoslav Republic of Macedonia, 41 (vacant), 42 for the European Community (Approvals are granted by its Member States using their respective ECE symbol), 43 for Japan, 44 (vacant), 45 for Australia and 46 for Ukraine. Subsequent numbers shall be assigned to other countries in the chronological order in which they ratify or accede to the Agreement Concerning the Adoption of Uniform Technical Prescriptions for Wheeled Vehicles, Equipment and Parts which can be Fitted and/or be Used on Wheeled Vehicles and the Conditions for Reciprocal Recognition of Approvals Granted on the Basis of these Prescriptions, and the numbers thus assigned shall be communicated by the Secretary-General of the United Nations to the Contracting Parties to the Agreement.

⁽²⁾ See footnote to paragraph 4.2.4.1.

- 4.3.4.2. the approval number placed below the circle.
- 4.3.4.3. the symbol R94-01 in the case of an approval pursuant paragraph 5.2.1 below.
- 4.3.5. The approval mark shall be clearly legible and be indelible.
- 4.4. Annex 2 to this Regulation gives examples of arrangements of approval marks.
5. SPECIFICATIONS
- 5.1. When the unladen vehicle, in running order, without a manikin, is collision-tested against a barrier at a speed of 48,3 km/h (30 mph), the top of the steering column and its shaft shall not move backwards, horizontally and parallel to the longitudinal axis of the vehicle, by more than 12,7 cm and also not more than 12,7 cm vertically upwards, both dimensions considered in relation to a point of the vehicle not affected by the impact ⁽¹⁾.
- 5.1.1. In the case of a vehicle powered by an electric motor, the impact test prescribed in paragraph 5.1 shall be carried out with the propulsion battery master switch in the 'ON' position. In addition, the following requirements shall be satisfied during and after the test.
- 5.1.1.1. The monoblocs shall remain fixed in their places;
- 5.1.1.2. No liquid electrolyte shall leak into the passenger compartment; a limited leakage is permissible, however, only to outside the vehicle, provided that the leakage which occurs during the first hour after the test does not exceed 7 per cent of the total of the liquid electrolyte in the propulsion battery.
- 5.1.2. Specifications of paragraph 5.1 above are deemed to be met if the vehicle equipped with such a steering system complies with the specifications of paragraph 5.2.2 of Regulation No 94, 01 series of amendments.
- 5.2. When the steering control is struck by a body block released against this control at a relative speed of 24,1 km/h (15 mph), the force applied to the body block by the steering control shall not exceed 1 111 daN.
- 5.2.1. If the steering control is fitted with a steering wheel airbag, specifications of paragraph 5.2 above are deemed to be met if the vehicle equipped with such a steering system complies with the specifications of paragraphs 5.2.1.4 and 5.2.1.5 of Regulation No 94, 01 series of amendments.
- 5.3. When the steering control is struck by an impactor released against this control at a relative speed of 24,1 km/h, in accordance with the procedures of Annex 5, the deceleration of the impactor shall not exceed 80 g cumulative for more than 3 milliseconds. The deceleration shall always be lower than 120 g with C.F.C. 600 Hz.
- 5.4. The steering control shall be designed, constructed and fitted in such a way that:
- 5.4.1. Before the impact test prescribed in paragraphs 5.2 and 5.3 above no part of the steering control surface, directed towards the driver, which can be contacted by a sphere of 165 mm in diameter shall present any roughness or sharp edges with a radius of curvature of less than 2.5 mm.

⁽¹⁾ See Annex 3, paragraph 3.1.

- 5.4.1.1. After any impact test prescribed in paragraphs 5.2 and 5.3 the part of the steering control surface directed towards the driver shall not present any sharp or rough edges likely to increase the danger or severity of injuries to the driver. Small surface cracks and fissures shall be disregarded.
- 5.4.1.1.1. In the case of a projection consisting of a component made of non-rigid material of less than 50 Shore A hardness mounted on rigid support, the requirement of paragraph 5.4.1.1 shall only apply to the rigid support.
- 5.4.2. The steering control shall be so designed, constructed and fitted as not to embody components or accessories, including the horn control and assembly accessories, capable of catching in the driver's clothing or jewellery in normal driving movements.
- 5.4.3. In the case of steering controls not intended to form part of the original equipment they shall be required to meet the specification when tested in accordance with Annex 4, paragraph 2.1.3 and Annex 5, paragraph 2.3.
- 5.4.4. In the case of 'general steering controls', the requirements shall be met over:
- 5.4.4.1. the full range of column angles, it being understood that the tests shall be performed at least for the maximum and minimum column angles for the range of approved vehicle types for which the controls are intended;
- 5.4.4.2. the full range of possible impactor and body block positions in relation to the steering control, it being understood that the test shall be performed at least for the mean position for the range of approved vehicle types for which the controls are intended. Where a steering column is used, it shall be of a type corresponding to the 'worst case' conditions.
- 5.4.5. Where adaptors are used to adapt a single type of steering control to a range of steering column, and it can be demonstrated that with such adaptors the energy-absorbing characteristics of the system are the same, all the tests may be performed with one type of adaptor.
6. TESTS
- 6.1. Compliance with the requirements of paragraph 5 above shall be checked in accordance with the methods set out in Annexes 3, 4 and 5 to this Regulation. All measurements should be done on the basis of ISO 6487:1987.
- 6.2. However, other tests may be permitted at the discretion of the Approval Authority provided equivalence can be demonstrated. In such a case a report shall be attached to the approval documentation describing the methods used and the results obtained.
7. MODIFICATIONS AND EXTENSION OF APPROVAL OF THE VEHICLE TYPE OR STEERING CONTROL TYPE
- 7.1. Every modification of the vehicle type or steering control type or both shall be notified to the administrative department which approved the vehicle type or the steering control type. The department may then either:
- 7.1.1. consider that the modifications made are unlikely to have an appreciable adverse effect and that in any case the vehicle still complies with the requirements; or

- 7.1.2. require a further test report from the technical service responsible for conducting the tests.
- 7.2. Without prejudice to the provisions of paragraph 7.1 above, a variant of the vehicle whose mass in the running order is less than that of the vehicle subjected to the approval test shall not be regarded as a modification of the vehicle type.
- 7.3. Confirmation or refusal of approval, specifying the alteration shall be communicated by the procedure specified in paragraphs 4.2.3 or 4.3.3 above to the Parties to the Agreement applying this Regulation.
- 7.4. The competent authority issuing the extension of approval shall assign a series number for such an extension and inform thereof the other Parties to the 1958 Agreement applying this Regulation by means of a communication form conforming to the model in Annex 1A or Annex 1B to this Regulation.
8. CONFORMITY OF PRODUCTION
- 8.1. Every vehicle or steering control approved under this Regulation shall be so manufactured as to conform to the type approved by meeting the requirements set out in paragraphs 5 and 6 above.
- 8.2. In order to verify that the requirements of paragraph 8.1 are met, suitable checks of the production shall be carried out.
- 8.3. The holder of the approval shall, in particular:
- 8.3.1. ensure the existence of procedures for effective quality control of the vehicle or steering control;
- 8.3.2. have access to the testing equipment necessary for checking conformity to each approved type;
- 8.3.3. ensure that test result data are recorded and that the annexed documents remain available for a period to be determined in agreement with the administrative department;
- 8.3.4. analyse the results of each type of test, in order to verify and ensure the consistency of characteristics of the vehicle or steering control, making allowance for permissible variations in industrial production;
- 8.3.5. ensure that for each type of vehicle or steering control at least the tests concerning the taking of measurements are carried out;
- 8.3.6. ensure that any set of samples or test pieces giving evidence of non-conformity in the type of test in question shall give rise to a further sampling and test. All necessary steps shall be taken to restore conformity of the corresponding production.
- 8.4. The competent authority which has granted type approval may at any time verify the conformity control methods applied in each production unit.
- 8.4.1. At every inspection, the test records and production records shall be presented to the visiting inspector.
- 8.4.2. The inspector may select samples at random to be tested in the manufacturer's laboratory. The minimum number of samples may be determined according to the results of the manufacturer's own checks.
- 8.4.3. Where the quality level appears unsatisfactory or it seems necessary to verify the validity of the tests carried out in application of paragraph 8.4.2, the inspector shall select samples to be sent to the technical service which conducted the type approval tests.

- 8.4.4. The competent authority may carry out any test prescribed in this Regulation. The normal frequency of inspections authorized by the competent authority shall be one per year. In cases where unsatisfactory results are found during one of these inspections, the competent authority shall ensure that all necessary steps are taken to restore conformity of production as rapidly as possible.

9. PENALTIES FOR NON-CONFORMITY OF PRODUCTION

- 9.1. The approval granted in respect of a vehicle type or steering control type, pursuant to this Regulation, may be withdrawn if the requirement laid down in paragraph 8.1 above is not complied with, or if the vehicle(s) or steering control(s) selected have failed to pass the checks prescribed in paragraph 8.2 above.

- 9.2. If a Contracting Party to the Agreement applying this Regulation withdraws an approval it has previously granted, it shall forthwith so notify the other Contracting Parties applying this Regulation by means of a communication form conforming to the model in Annex 1A or Annex 1B to this Regulation (as appropriate).

10. INSTRUCTIONS

In the case of a steering control type supplied separately from a vehicle, the packaging and installation instructions must clearly state the vehicle type(s) for which it is intended.

11. PRODUCTION DEFINITELY DISCONTINUED

If the holder of the approval completely ceases to manufacture a type of vehicle or type of steering control approved in accordance with this Regulation, he shall so inform the authority which granted the approval. Upon receiving the relevant communication that authority shall inform thereof the other Parties to the 1958 Agreement applying this Regulation by means of a communication form conforming to the model in Annex 1A or Annex 1B to this Regulation (as appropriate).

12. NAMES AND ADDRESSES OF TECHNICAL SERVICES RESPONSIBLE FOR CONDUCTING APPROVAL TESTS, AND OF ADMINISTRATIVE DEPARTMENTS

The Parties to the Agreement applying this Regulation shall communicate to the United Nations Secretariat the names and addresses of the technical services responsible for conducting approval tests and of the administrative departments which grant approval and to which forms certifying approval or extension, refusal or withdrawal of approval, issued in other countries, are to be sent.

13. TRANSITIONAL PROVISIONS

- 13.1. As from the official date of entry into force of the 03 series of amendments to this Regulation, no Contracting Party shall refuse an application for approval submitted in accordance with this Regulation as amended by the 03 series of amendments.

13.2. Approvals of vehicle type

- 13.2.1. Upon the expiration of a period of 36 months following the official date of entry into force referred to in paragraph 13.1 above, Contracting Parties applying this Regulation shall grant approval for category M₁ forward-control vehicles and category N₁ vehicles of less than 1.5 tonnes only if the vehicle type satisfies the requirements of this Regulation as amended by the 03 series of amendments, with the exception of the provisions laid down in paragraph 5.1 of this Regulation concerning the maximum vertical displacement of the steering column, which shall apply to new approvals only after a further period of 12 months.

- 13.2.2. Upon the expiration of a period of 48 months following the official date of entry into force referred to in paragraph 13.1 above, Contracting Parties applying this Regulation shall grant approval to category M₁ vehicles other than forward-control vehicles only if the vehicle type satisfies the requirements of this Regulation as amended by the 03 series of amendments.
- 13.2.3. Upon the expiration of a period of 60 months following the official date of entry into force referred to in paragraph 13.1 above, Contracting Parties applying this Regulation may refuse to recognize approvals of the vehicle type which have not been granted in accordance with the 03 series of amendments to this Regulation.
- 13.3. **Approvals of type of steering control**
- 13.3.1. Upon the expiration of a period of 24 months following the official date of entry into force referred to in paragraph 13.1 above, Contracting Parties applying this Regulation shall grant approval only if the type of steering control satisfies the applicable requirements of this Regulation as amended by the 03 series of amendments.
- 13.3.2. Upon the expiration of a period of 36 months following the official date of entry into effect referred to in paragraph 13.1 above, Contracting Parties applying this Regulation may refuse to recognize approvals of the type of steering control which have not been granted in accordance with the 03 series of amendments to this Regulation.
- 13.3.3. As from the official date of entry into force of Supplement 2 to the 03 series of amendments, Contracting Parties shall not grant separate approvals of the type of steering control which include an airbag.
- 13.3.4. As from the official date of entry into force of Supplement 2 to the 03 series of amendments, Contracting Parties may refuse to recognize separate approvals of the type of steering control which include an airbag.
-

ANNEX 1A

COMMUNICATION

(maximum format: A4 (210 × 297 mm))



issued by: Name of administration:

concerning ⁽²⁾: APPROVAL GRANTED
 APPROVAL EXTENDED
 APPROVAL REFUSED
 APPROVAL WITHDRAWN
 PRODUCTION DEFINITELY DISCONTINUED

of a vehicle type with regard to the protection of the driver against the steering mechanism in the event of impact, pursuant to Regulation No 12.

Approval No Extension No

1. Trade name or mark of the vehicle
2. Vehicle type
3. Manufacturer's name and address
4. If applicable, name and address of manufacturer's representative
5. Brief description of the steering mechanism and the components of the vehicle contributing to the protection of the driver against the steering mechanism in the event of impact
6. Mass of the vehicle during the test
 front axle:
 rear axle:
 total:
7. Vehicle submitted for approval on
8. Technical service responsible for conducting approval tests
9. Date of report issued by that service
10. Number of report issued by that service
11. Approval granted/refused/extended/withdrawn ⁽²⁾
12. Position of approval mark on the vehicle
13. Place
14. Date
15. Signature
16. The list of documents deposited with the Administrative Service which has granted approval is annexed to this communication and may be obtained on request.

⁽¹⁾ Distinguishing number of the country which has granted/extended/refused/withdrawn approval (see approval provisions in the Regulation).

⁽²⁾ Strike out what does not apply.

ANNEX 1B

COMMUNICATION

(maximum format: A4 (210 × 297 mm))

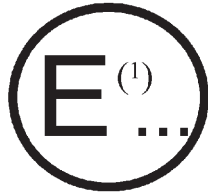

issued by: Name of administration:

.....

concerning ⁽²⁾: APPROVAL GRANTED
 APPROVAL EXTENDED
 APPROVAL REFUSED
 APPROVAL WITHDRAWN
 PRODUCTION DEFINITELY DISCONTINUED

of a steering control type with regard to the protection of the driver against the steering mechanism in the event of impact, pursuant to the relevant part of Regulation No 12.

Approval No Extension No

1. Trade name or mark of the steering control
2. Manufacturer's name and address
3. If applicable, name and address of the manufacturer's representative
4. Vehicle type(s) to which the control is intended to be fitted
5. Brief description of the steering control and of the components contributing to the protection of the driver against the steering mechanism in the event of impact
6. Steering control submitted for approval on
7. Technical service responsible for conducting approval tests
8. Date of report issued by that service
9. Number of report issued by that service
10. Approval granted/refused/extended/withdrawn ⁽²⁾
11. Position of approval mark or marks on the steering control
12. Place
13. Date
14. Signature
15. The list of documents deposited with the Administrative Service which has granted approval is annexed to this communication and may be obtained on request.

⁽¹⁾ Distinguishing number of the country which has granted/extended/refused/withdrawn approval (see approval provisions in the Regulation).

⁽²⁾ Strike out what does not apply.

ANNEX 2

ARRANGEMENTS OF APPROVAL MARKS

MODEL A

(See paragraph 4.2.4 of this Regulation)

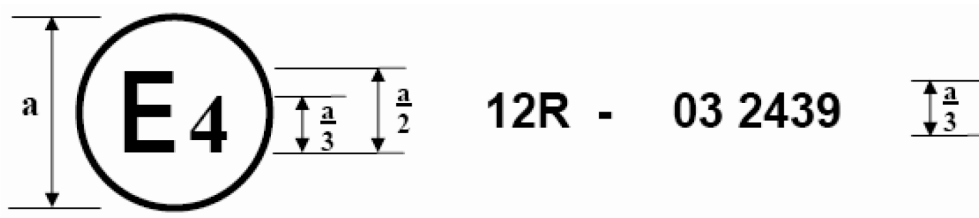
**a = 8 mm min.**

The above approval mark affixed to a vehicle shows that the vehicle type concerned has, with regard to the protection of the driver against the steering mechanism in the event of impact, been approved in the Netherlands (E4) pursuant to Regulation No 12. The approval number indicates that the approval was granted according to the requirements of Regulation No 12 as amended by the 03 series of amendments.

MODEL B

(See paragraph 4.2.5 of this Regulation)

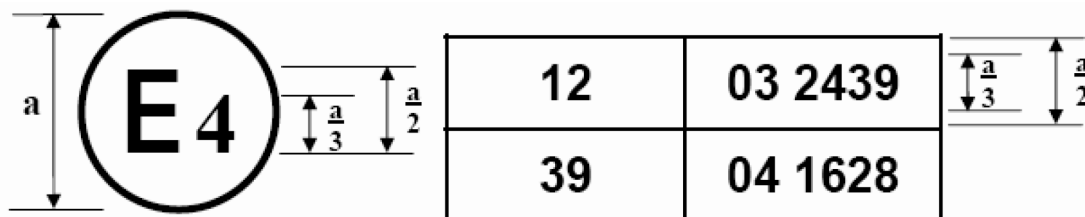
**a = 8 mm min.**

The above approval mark affixed to a vehicle shows that the vehicle type concerned has been approved in the Netherlands (E4) pursuant to Regulations Nos 12 and 39⁽¹⁾. The approval numbers indicate that, at the dates when the respective approvals were given, Regulation No 12 included the 03 series of amendments and Regulation No 39 the 04 series of amendments.

⁽¹⁾ The second number is given merely as an example.

MODEL C

(See paragraph 4.3.4 of this Regulation)

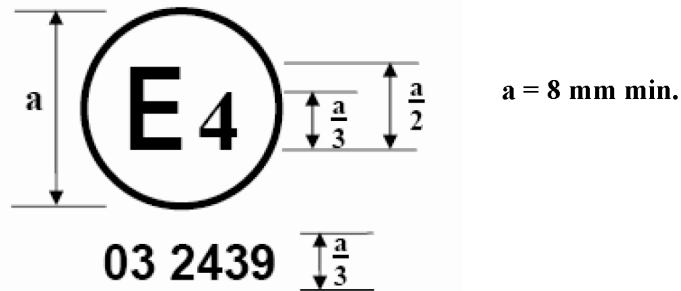

The above approval mark affixed to a steering control shows that the steering control type concerned has, with regard to the protection of the driver against the steering mechanism in the event of impact, been approved in the Netherlands (E4) pursuant to the relevant part of Regulation No 12 as amended by the 03 series of amendments.

MODEL D

(See paragraph 4.3.4.3 of this Regulation)

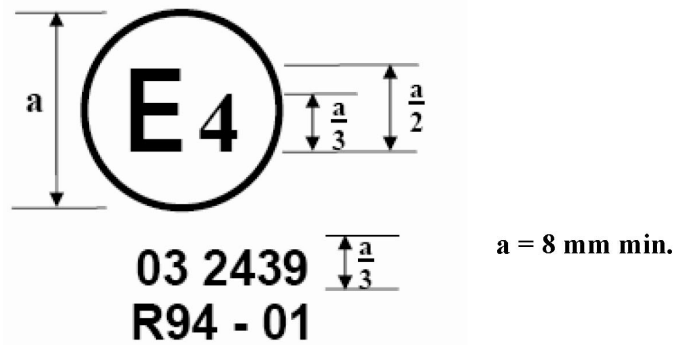

The above approval mark affixed to a steering control shows that the steering control type concerned has been approved in the Netherlands (E4) with regard to the protection of the driver against the steering mechanism in the event of impact, pursuant to provisions of paragraphs 5.2.1 and/or 5.3.1 of Regulation No 12 as amended by the 03 series of amendments.

ANNEX 3

FRONTAL-IMPACT TEST AGAINST A BARRIER**1. PURPOSE**

The purpose of this test is to verify whether the vehicle satisfies the requirements set forth in paragraph 5.1.

2. INSTALLATIONS, PROCEDURE AND MEASURING INSTRUMENTS**2.1. Testing ground**

The test area shall be large enough to accommodate the run-up track, barrier and technical installations necessary for the test. The last part of the track, for at least 5 m before the barrier, shall be horizontal (slope less than 3 % measured over a length of one metre), flat and smooth.

2.2. Barrier

The barrier shall consist of a block of reinforced concrete not less than 3 m wide in front and not less than 1,5 m high. The barrier shall be of such thickness that it weighs at least 70 metric tons. The front face shall be flat, vertical and perpendicular to the axis of the run-up track. It shall be covered with plywood boards 19 ± 1 mm thick, in good condition. A structure on a steel plate at least 25 mm thick may be placed between the plywood board and the barrier. A barrier with different characteristics may likewise be used, provided that the area of the impact surface is greater than the frontal crash area of the vehicle being tested and provided that it gives equivalent results.

2.3. Propulsion of vehicle

At the moment of impact the vehicle shall no longer be subject to the action of any additional steering or propelling device. It shall reach the obstacle on a course perpendicular to the collision wall; the maximum lateral misalignment tolerated between the vertical median line of the front of the vehicle and the vertical median line of the collision wall is ± 30 cm.

2.4. State of vehicle

- 2.4.1. For the test, the vehicle shall either be fitted with all the normal components and equipment included in its unladen kerb mass or be in such a condition as to satisfy this requirement so far as the components and equipment of concern to the passenger compartment and the distribution of the mass of the vehicle as a whole, in running order, are concerned.

At the request of the manufacturer, by derogation from paragraph 5.1 of this Regulation, the test may be carried out with manikins in position, provided they do not at any time hinder the movement of the steering mechanism. The mass of the manikins shall not be taken into account for the purposes of the test.

- 2.4.2. If the vehicle is driven by external means, the fuel feed system shall be filled to at least 90 % of its capacity with a non-inflammable liquid having a density between 0,7 and 1. All the other systems (brake fluid reservoirs, radiator, etc.) may be empty.

- 2.4.3. If the vehicle is driven by its own engine, the fuel tank shall be at least 90 % full. All other reservoirs shall be filled to capacity.

If the manufacturer so desires and the technical service agrees, the fuel feed to the engine may be provided from an auxiliary tank of small capacity. In such case, the fuel tank shall be filled to not less than 90 % of its capacity with a non-inflammable liquid of a density between 0,7 and 1.

- 2.4.4. If the manufacturer so requests, the technical service responsible for conducting the tests may allow the same vehicle as is used for tests prescribed by other Regulations (including tests capable of affecting its structure) to be used also for the tests prescribed by this Regulation.

- 2.4.5. The steering wheel, if adjustable, shall be placed in the normal position indicated by the manufacturer or, failing that, midway between the limits of its range(s) of adjustment.

2.5. Speed on impact

The speed on impact shall be between 48,3 km/h (30 mph) and 53,1 km/h (33 mph). However, if the test has been carried out at a higher impact speed and the vehicle has met the requirements laid down, the test shall be considered satisfactory.

2.6. Measuring instruments

The instrument used to record the speed referred to in paragraph 2.5 above shall be accurate to within 1 %.

3. RESULTS

3.1. To determine the rear- and upward movement of the steering control, a recording ⁽¹⁾ shall be made, during the collision, of the variation in the distance — measured horizontally ⁽²⁾ and parallel to the longitudinal axis of the vehicle, and vertically, in the direction perpendicular to that axis — between the top of the steering column (and shaft) and a point on the vehicle which is not affected by the impact. The largest value of this variation, taken from the recording, shall be taken as the rear- and upward movement.

3.2. After the test, the damage sustained by the vehicle shall be described in a written report; one photograph at least shall be taken of each of the following views of the vehicle:

3.2.1. sides (right and left),

3.2.2. front,

3.2.3. bottom,

3.2.4. affected area inside the passenger compartment.

4. CORRECTION FACTORS

4.1. Notation

V Recorded speed in km/h;

m_0 Mass of prototype in the state defined in paragraph 2.4 of this Annex;

m_1 Mass of prototype with testing apparatus;

D_0 Variation in the distance measured during the impact, as defined in paragraph 3.1 of this Annex;

D_1 Variation in the distance used to determine the results of the test;

K_1 = the greater of $\frac{(48,3)^2}{V}$ and 0,83;

K_2 = the greater of m_0/m_1 and 0,8.

4.2. The corrected variation D_1 used to check the conformity of the prototype with the requirements of this Regulation shall be calculated by the following formula:

$$D_1 = D_0 \cdot K_1 \cdot K_2$$

4.3. A frontal impact test against a barrier is not needed in the case of a vehicle which is identical with the prototype considered as regards the characteristics specified in paragraph 2.2 of this Regulation but whose mass m_1 is greater than m_0 , if m_1 is not more than 1,25 m_0 and if the corrected variation D_2 obtained from the variation D_1 by the formula $D_2 = (m_1/m_0) \cdot D_1$ is such as to show that the new vehicle still meets the requirements of paragraph 5 of this Regulation.

5. EQUIVALENT PROCEDURES

5.1. Alternative tests may be permitted at the discretion of the Approval Authority provided equivalence can be demonstrated. A report shall be attached to the approval documentation describing the method used and the results obtained or the reason for not carrying out the test.

5.2. Responsibility for demonstrating the equivalence of the alternative method shall rest with the manufacturer or his agent wishing to use such a method.

⁽¹⁾ This recording may be replaced by maximum measurements.

⁽²⁾ 'Horizontally' means with reference to the passenger compartment when the vehicle is immobile before the test, not in space during movement of the vehicle in relation to the ground, and 'vertically' is perpendicular to horizontally and upwards.

ANNEX 4

BODY BLOCK TEST

1. PURPOSE

The purpose of this test is to verify whether the vehicle meets the requirements set out in paragraph 5.2 of this Regulation.

2. INSTALLATIONS, PROCEDURES AND MEASURING INSTRUMENTS

2.1. **Mounting of the steering control**

2.1.1. The control shall be mounted on the front section of the vehicle obtained by cutting the body transversely at the level of the front seats, and possibly eliminating the roof, windscreen and doors. This section shall be fixed rigidly to the test bench, so that it does not move under the impact of the body block.

The tolerance on the control mounting angle shall be ± 2 degrees of the design angle.

2.1.2. However, at the request of the manufacturer and with the agreement of the technical service, the steering control may be mounted on a framework simulating the mounting of the steering mechanism, provided that, as compared with the real 'front body section/steering mechanism' assembly the 'framework/steering mechanism' assembly has:

2.1.2.1. the same geometrical layout,

2.1.2.2. greater rigidity.

2.1.3. Mounting of the steering control when seeking steering control approval only. The steering control shall be tested complete with trim. The steering control must have a minimum collapsing space of 100 mm between the steering control and the test bench. The steering shaft shall be firmly attached to the test bench so that the steering shaft does not move under impact (see fig. 2).

2.2. **Setting of the steering mechanism for the tests**

2.2.1. During the first test, the steering control shall be turned so that its most rigid spoke is perpendicular to the point of contact with the body block; if the steering control is a steering wheel, the test shall be repeated with the most flexible part of the steering wheel perpendicular to that point of contact. In the case of an adjustable steering control, both tests shall be made with the wheel adjusted to the normal position indicated by the manufacturer or, failing that, midway between the limits of its range(s) of adjustment.

2.2.2. If the vehicle is equipped with a device to adjust the slope and position of the steering wheel, the test shall be performed with the latter in the normal position of use indicated by the manufacturer and regarded by the laboratory as representative from the standpoint of energy absorption.

2.2.3. If the steering control is fitted with a steering wheel air-bag, the test shall be carried out with the air-bag inflated. At the request of the manufacturer and with the consent of the technical service the test may be carried out without the air-bag inflated.

2.3. **Body block**

The body block shall have the shape, dimensions, mass and characteristics shown in the appendix to this Annex.

2.4. **Measurement of forces**

2.4.1. Measurements shall be made of the maximum force, acting horizontally and parallel to the longitudinal axis of the vehicle, applied to the body block as a result of impact against the steering control.

2.4.2. This force may be measured directly or indirectly or may be calculated from values recorded during the test.

2.5. Propulsion of the body block

- 2.5.1. Any method of propulsion may be used, provided that when the body block strikes the steering control it is free from all connection with the propelling device. The body block shall strike this control after an approximately straight trajectory parallel to the longitudinal axis of the vehicle.
- 2.5.2. The H point of the body block, indicated by a special mark, shall be so adjusted that before the impact it is in the horizontal plane passing through the R point as indicated by the manufacturer of the vehicle.

2.6. Speed

The body block shall strike the steering control at a speed of $24,1 \text{ km/h}^{+1,2}$ ($15 \text{ mph}^{+0,8}$). However, if the test has been carried out at a higher impact speed and the control has met the requirements laid down, the test shall be considered satisfactory.

2.7. Measuring instruments

- 2.7.1. The instrumentation used to record the parameters referred to in paragraph 5.2 of this Regulation shall enable the measurements to be made with the following accuracy:
- 2.7.1.1. Speed of body block: within 2 %;
- 2.7.1.2. Time recording: within 1/1 000 second;
- 2.7.1.3. The beginning of the impact (zero point) at the moment of first contact of the body block with the steering control shall be identified on the recordings and films used for analysing the results of the test.
- 2.7.1.4. Measurement of force

The instrumentation used shall comply with ISO 6487:1987 unless otherwise specified in this Regulation.

- 2.7.1.4.1. With load transducers inserted on the steering system:

The channel amplitude class shall be 1 960 daN (2 000 kg) and the channel frequency class 600.

- 2.7.1.4.2. With accelerometers or load transducers inserted on the body block: Two unidirectional accelerometers shall be placed symmetrically in the transverse plane of the centre of gravity of the body block. The channel amplitude class shall be 60 g and the channel frequency class 180. Other methods with regard to the number and positioning of the measuring accelerometers shall be allowed, such as by dividing the test apparatus in separate parts at the centre of gravity of which accelerometers are placed to measure the acceleration horizontally and parallel to the longitudinal axis of the vehicle.

The resultant force shall be the force corresponding to the maximum of the sum of forces calculated or measured directly for each part of the body block.

- 2.8. Ambient temperature: stabilized at $20 \text{ °C} \pm 5 \text{ °C}$.

3. RESULTS

- 3.1. After the test, the damage sustained by the steering mechanism shall be ascertained and described in a written report; at least one side-view and one front-view photograph of the 'steering control/steering column/instrument panel' area shall be taken.
- 3.2. The maximum value of the force shall be measured or calculated as indicated in paragraph 2.4.

Appendix

(Mass: 34-36 kg. 50th percentile torso-shaped body block)

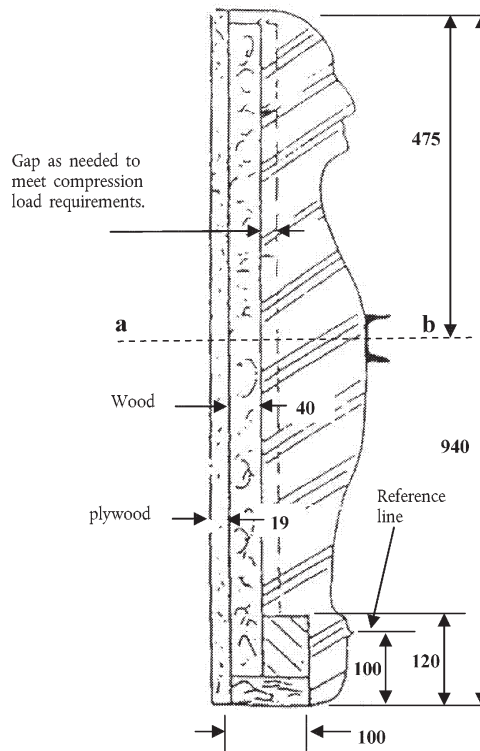
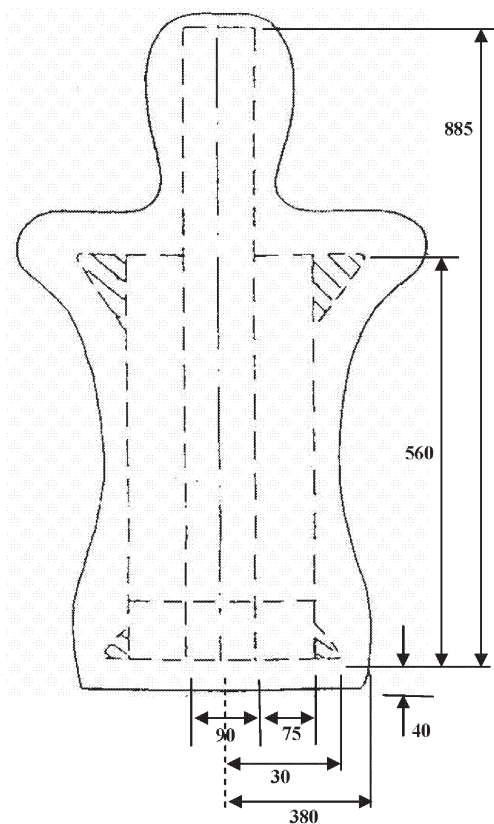

Spring rate: 107-143 kgf/cm.
 The chest is loaded with a 100 mm beam as shown, 90° to the longitudinal axis of the block and parallel to the backing plate. The load is measured when the beam has moved 12.7 mm into the body block.

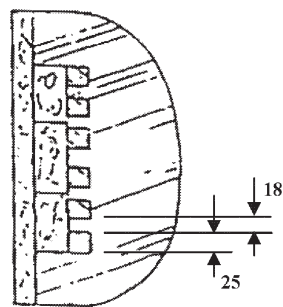

section a - b

All Dimensions in mm.

Rubber-like material strapped and taped to backing plate.

ANNEX 5

Head form test

1. PURPOSE

The purpose of this text is to verify whether the steering control meets the requirements set out in paragraph 5.3 of this Regulation.

2. INSTALLATIONS, PROCEDURES AND MEASURING INSTRUMENTS

2.1. **General**

2.1.1. The steering control shall be tested complete with trim.

2.1.2. If the steering control is fitted with a steering wheel air-bag, the test shall be carried out with the air-bag inflated. At the request of the manufacturer and with the consent of the technical service the test may be carried out without the air-bag inflated.

2.2. **Mounting of the steering control when seeking steering control approval related to vehicle approval**

2.2.1. The control shall be mounted on the front section of the vehicle obtained by cutting the body transversely at the level of the front seats and possibly eliminating the roof, windscreen and doors.

This section shall be fixed rigidly to the test bench so that it does not move under the impact of the head form.

The tolerance on the control mounting angle shall be ± 2 degrees of the design angle.

2.2.2. However, at the request of the manufacturer and with the agreement of the technical service, the steering control may be mounted on a framework simulating the mounting of the steering mechanism, provided that, as compared with the real 'front body section/steering mechanism' assembly, the 'framework/steering mechanism' assembly has:

2.2.2.1. the same geometric layout,

2.2.2.2. greater rigidity.

2.3. **Mounting the steering control when seeking steering control approval only**

The steering control shall be tested complete with trim. The steering control must have a minimum collapsing space of 100 mm between the steering control and the test bench. The steering shaft shall be firmly attached to the test bench so that the steering shaft does not move under impact (see fig. 1).

2.3.1. However, at the request of the manufacturer the test may be carried out under the conditions specified in paragraph 2.2 above. In such case the approval will only be valid for the specified type(s) of vehicle(s).

3. TEST APPARATUS

3.1. This apparatus consists of a fully guided linear impactor, rigid, with a mass of 6.8 kg. Its impact surface is hemispherical with a diameter of 165 mm.

3.2. The head-form shall be fitted with two accelerometers and a speed-measuring device, all capable of measuring values in the impact direction.

3.3. Measuring instruments

3.3.1. The measuring instruments used shall comply with ISO 6487:1987. In addition they shall have the following characteristics:

3.3.2. Acceleration

Channel amplitude class 150 g CAC

Channel frequency class 600 Hz CFC.

3.3.3. Speed

Accuracy to within $\pm 1\%$

3.3.4. Time recording

The instrumentation shall enable the action to be recorded throughout its duration and the readings to be made with the accuracy to one-thousandth of a second. The beginning of the impact at the moment of first contact between the impactor and the steering control shall be noted on the recordings used for analysing the test.

4. TEST PROCEDURE

4.1. The plane of the steering control shall be set up perpendicular to the direction of impact.

4.2. A maximum of four and a minimum of three positions on each steering control wheel type shall be impacted. A new steering control shall be used for each impact. On successive impacts the axial axis of the impactor shall be in line with one of the following points:

4.2.1. The centre of the steering control boss;

4.2.2. The joint of the stiffest or most supported spoke to the inner edge of the steering control rim;

4.2.3. The mid-point of the shortest unsupported area of the steering control rim that does not include a spoke when hit by the head form;

4.2.4. At the discretion of the type approving authority, the 'worst case' position on the steering control.

4.3. The impactor shall strike the steering control at a velocity of 24.1 km/h; this velocity shall be achieved either by the mere energy of propulsion or by using an additional propelling device.

5. RESULTS

5.1. In the tests carried out according to the above procedures, the deceleration rate of the impactor shall be taken as the simultaneous average of the readings of the two decelerometers.

6. EQUIVALENT PROCEDURES

6.1. Alternative tests may be permitted at the discretion of the Approval Authority provided equivalence can be demonstrated. A report shall be attached to the approval documentation describing the method used and the results obtained.

6.2. Responsibility for demonstrating the equivalence of the alternative method shall rest with the manufacturer or his agent wishing to use such a method.

Figure 1a
Testing set-up

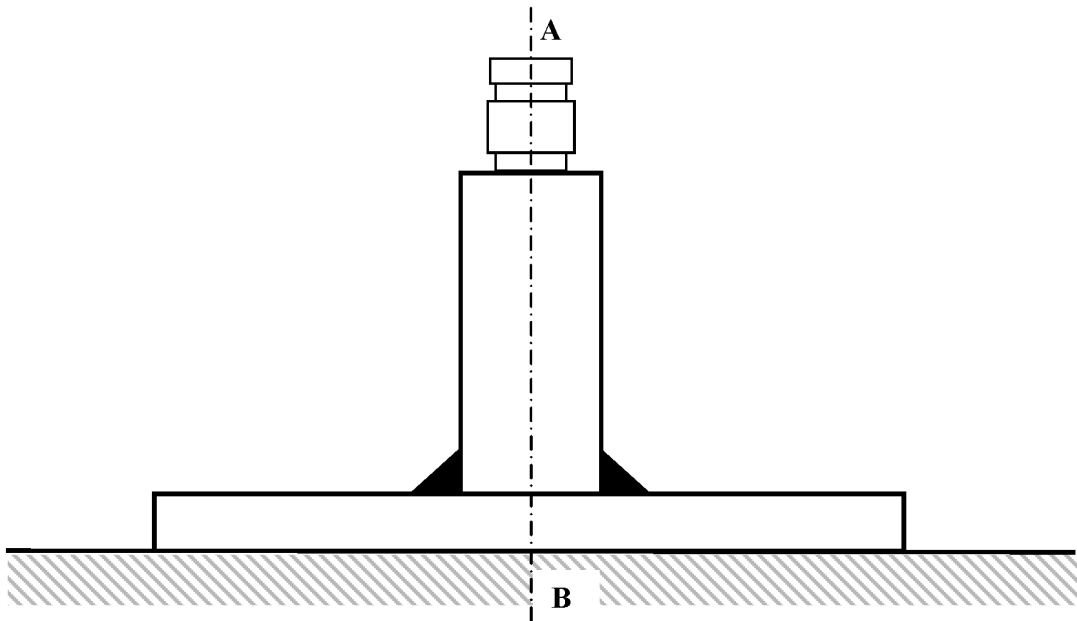
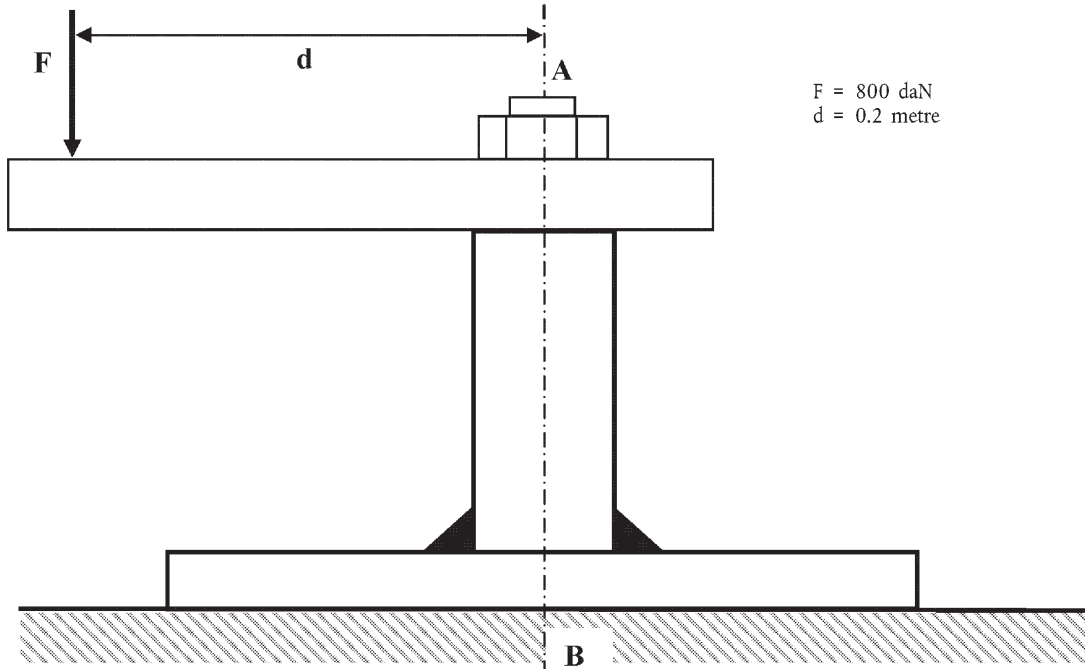

Fig. 1b
Measurement of the testing set-up rigidity



Under a load of 800 daN producing a couple of 160 mdaN in relation to the point 'B', the displacement in any direction of the point 'A' shall be lower than 2 mm

ANNEX 6

Procedure for determining the 'H' point and the actual torso angle for seating positions in motor vehicles

1. PURPOSE

The procedure described in this Annex is used to establish the 'H' point location and the actual torso angle for one or several seating positions in a motor vehicle and to verify the relationship of measured data to design specifications given by the vehicle manufacturer ⁽¹⁾.

2. DEFINITIONS

For the purposes of this Annex:

2.1. 'Reference data' means one or several of the following characteristics of a seating position:

2.1.1. the 'H' point and the 'R' point and their relationship,

2.1.2. the actual torso angle and the design torso angle and their relationship.

2.2. 'Three-dimensional "H" point machine' (3-D H machine) means the device used for the determination of 'H' points and actual torso angles. This device is described in Appendix 1 to this Annex;

2.3. 'H point' means the pivot centre of the torso and the thigh of the 3-D H machine installed in the vehicle seat in accordance with paragraph 4 below. The 'H' point is located in the centre of the centreline of the device which is between the 'H' point sight buttons on either side of the 3-D H machine. The 'H' point corresponds theoretically to the 'R' point (for tolerances see paragraph 3.2.2 below). Once determined in accordance with the procedure described in paragraph 4, the 'H' point is considered fixed in relation to the seat-cushion structure and to move with it when the seat is adjusted;

2.4. ' "R" point' or 'seating reference point' means a design point defined by the vehicle manufacturer for each seating position and established with respect to the three-dimensional reference system;

2.5. 'Torso-line' means the centreline of the probe of the 3-D H machine with the probe in the fully rearward position;

2.6. 'Actual torso angle' means the angle measured between a vertical line through the 'H' point and the torso line using the back angle quadrant on the 3-D H machine. The actual torso angle corresponds theoretically to the design torso angle (for tolerances see paragraph 3.2.2 below);

2.7. 'Design torso angle' means the angle measured between a vertical line through the 'R' point and the torso line in a position which corresponds to the design position of the seat-back established by the vehicle manufacturer;

2.8. 'Centreplane of occupant' (C/LO) means the median plane of the 3-D H machine positioned in each designated seating position; it is represented by the coordinate of the 'H' point on the 'Y' axis. For individual seats, the centreplane of the seat coincides with the centreplane of the occupant. For other seats, the centreplane of the occupant is specified by the manufacturer;

2.9. 'Three-dimensional reference system' means a system as described in Appendix 2 to this Annex;

2.10. 'Fiducial marks' are physical points (holes, surfaces, marks or indentations) on the vehicle body as defined by the manufacturer;

2.11. 'Vehicle measuring attitude' means the position of the vehicle as defined by the coordinates of fiducial marks in the three-dimensional reference system.

⁽¹⁾ In any seating position other than front seats where the 'H' point cannot be determined using the 'Three-dimensional "H" point machine' or procedures, the 'R' point indicated by the manufacturer may be taken as a reference at the discretion of the competent authority.

3. REQUIREMENTS

3.1. Data presentation

For each seating position where reference data are required in order to demonstrate compliance with the provisions of the present Regulation, all or an appropriate selection of the following data shall be presented in the form indicated in Appendix 3 to this Annex:

- 3.1.1. the coordinates of the 'R' point relative to the three-dimensional reference system;
- 3.1.2. the design torso angle;
- 3.1.3. all indications necessary to adjust the seat (if it is adjustable) to the measuring position set out in paragraph 4.3 below.

3.2. Relationship between measured data and design specifications

- 3.2.1. The coordinates of the 'H' point and the value of the actual torso angle obtained by the procedure set out in paragraph 4 below shall be compared, respectively, with the coordinates of the 'R' point and the value of the design torso angle indicated by the vehicle manufacturer.
- 3.2.2. The relative positions of the 'R' point and the 'H' point and the relationship between the design torso angle and the actual torso angle shall be considered satisfactory for the seating position in question if the 'H' point, as defined by its coordinates, lies within a square of 50 mm side length with horizontal and vertical sides whose diagonals intersect at the 'R' point, and if the actual torso angle is within 5° of the design torso angle.
- 3.2.3. If these conditions are met, the 'R' point and the design torso angle, shall be used to demonstrate compliance with the provisions of this Regulation.
- 3.2.4. If the 'H' point or the actual torso angle does not satisfy the requirements of paragraph 3.2.2 above, the 'H' point and the actual torso angle shall be determined twice more (three times in all). If the results of two of these three operations satisfy the requirements, the conditions of paragraph 3.2.3 above shall apply.
- 3.2.5. If the results of at least two of the three operations described in paragraph 3.2.4 above do not satisfy the requirements of paragraph 3.2.2 above, or if the verification cannot take place because the vehicle manufacturer has failed to supply information regarding the position of the 'R' point or regarding the design torso angle, the centroid of the three measured points or the average of the three measured angles shall be used and be regarded as applicable in all cases where the 'R' point or the design torso angle is referred to in this Regulation.

4. PROCEDURE FOR 'H' POINT AND ACTUAL TORSO ANGLE DETERMINATION

- 4.1. The vehicle shall be preconditioned at the manufacturer's discretion, at a temperature of 20 ± 10 °C to ensure that the seat material reached room temperature. If the seat to be checked has never been sat upon, a 70 to 80 kg person or device shall sit on the seat twice for one minute to flex the cushion and back. At the manufacturer's request, all seat assemblies shall remain unloaded for a minimum period of 30 min. prior to installation of the 3-D H machine.
- 4.2. The vehicle shall be at the measuring attitude defined in paragraph 2.11 above.
- 4.3. The seat, if it is adjustable, shall be adjusted first to the rearmost normal driving or riding position, as indicated by the vehicle manufacturer, taking into consideration only the longitudinal adjustment of the seat, excluding seat travel used for purposes other than normal driving or riding positions. Where other modes of seat adjustment exist (vertical, angular, seat-back, etc.) these will then be adjusted to the position specified by the vehicle manufacturer. For suspension seats, the vertical position shall be rigidly fixed corresponding to a normal driving position as specified by the manufacturer.
- 4.4. The area of the seating position contacted by the 3-D H machine shall be covered by a muslin cotton, of sufficient size and appropriate texture, described as a plain cotton fabric having 18,9 threads per cm and weighing 0,228 kg/m² or knitted or non-woven fabric having equivalent characteristics. If test is run on a seat outside the vehicle, the floor on which the seat is placed shall have the same essential characteristics ⁽¹⁾ as the floor of the vehicle in which the seat is intended to be used.

⁽¹⁾ Tilt angle, height difference with a seat mounting, surface texture etc.

- 4.5. Place the seat and back assembly of the 3-D H machine so that the centreplane of the occupant (C/LO) coincides with the centreplane of the 3-D H machine. At the manufacturer's request, the 3-D H machine may be moved inboard with respect to the C/LO if the 3-D H machine is located so far outboard that the seat edge will not permit levelling of the 3-D H machine.
- 4.6. Attach the foot and lower leg assemblies to the seat pan assembly, either individually or by using the T-bar and lower leg assembly. A line through the 'H' point sight buttons shall be parallel to the ground and perpendicular to the longitudinal centreplane of the seat.
- 4.7. Adjust the feet and leg positions of the 3-D H machine as follows:
 - 4.7.1. **Designated seating position: driver and outside front passenger**
 - 4.7.1.1. Both feet and leg assemblies shall be moved forward in such a way that the feet take up natural positions on the floor, between the operating pedals if necessary. Where possible the left foot shall be located approximately the same distance to the left of the centreplane of the 3-D H machine as the right foot is to the right. The spirit level verifying the transverse orientation of the 3-D H machine is brought to the horizontal by readjustment of the seat pan if necessary, or by adjusting the leg and foot assemblies towards the rear. The line passing through the 'H' point sight buttons shall be maintained perpendicular to the longitudinal centreplane of the seat.
 - 4.7.1.2. If the left leg cannot be kept parallel to the right leg and the left foot cannot be supported by the structure, move the left foot until it is supported. The alignment of the sight buttons shall be maintained.
 - 4.7.2. **Designated seating position: outboard rear**

For rear seats or auxiliary seats, the legs are located as specified by the manufacturer. If the feet then rest on parts of the floor which are at different levels, the foot which first comes into contact with the front seat shall serve as a reference and the other foot shall be so arranged that the spirit level giving the transverse orientation of the seat of the device indicates the horizontal.
 - 4.7.3. **Other designated seating positions:**

The general procedure indicated in paragraph 4.7.1 above shall be followed except that the feet shall be placed as specified by the vehicle manufacturer.
- 4.8. Apply lower leg and thigh weights and level the 3-D H machine.
- 4.9. Tilt the back pan forward against the forward stop and draw the 3-D H machine away from the seat-back using the T-bar. Reposition the 3-D H machine on the seat by one of the following methods:
 - 4.9.1. If the 3-D H machine tends to slide rearward, use the following procedure. Allow the 3-D H machine to slide rearward until a forward horizontal restraining load on the T-bar is no longer required i.e. until the seat pan contacts the seat-back. If necessary, reposition the lower leg.
 - 4.9.2. If the 3-D H machine does not tend to slide rearward, use the following procedure. Slide the 3-D H machine rearwards by applying a horizontal rearward load to the T-bar until the seat pan contacts the seat-back (see figure 2 of Appendix 1 to this Annex).
- 4.10. Apply a 100 ± 10 N load to the back and pan assembly of the 3-D H machine at the intersection of the hip angle quadrant and the T-bar housing. The direction of load application shall be maintained along a line passing by the above intersection to a point just above the thigh bar housing (see figure 2 of Appendix 1 to this Annex). Then carefully return the back pan to the seat-back. Care must be exercised throughout the remainder of the procedure to prevent the 3-D H machine from sliding forward.
- 4.11. Install the right and left buttock weights and then, alternately, the eight torso weights. Maintain the 3-D H machine level.
- 4.12. Tilt the back pan forward to release the tension on the seat-back. Rock the 3-D H machine from side to side through a 10° arc (5° to each side of the vertical centreplane) for three complete cycles to release any accumulated friction between the 3-D H machine and the seat.

During the rocking action, the T-bar of the 3-D H machine may tend to diverge from the specified horizontal and vertical alignment. The T-bar must therefore be restrained by applying an appropriate lateral load during the rocking motions. Care shall be exercised in holding the T-bar and rocking the 3-D H machine to ensure that no inadvertent exterior loads are applied in a vertical or fore and aft direction.

The feet of the 3-D H machine are not to be restrained or held during this step. If the feet change position, they should be allowed to remain in that attitude for the moment.

Carefully return the back pan to the seat-back and check the two spirit levels for zero position. If any movement of the feet has occurred during the rocking operation of the 3-D H machine, they must be repositioned as follows:

Alternately, lift each foot off the floor the minimum necessary amount until no additional foot movement is obtained. During this lifting, the feet are to be free to rotate; and no forward or lateral loads are to be applied. When each foot is placed back in the down position, the heel is to be in contact with the structure designed for this.

Check the lateral spirit level for zero position; if necessary, apply a lateral load to the top of the back pan sufficient to level the 3-D H machine's seat pan on the seat.

- 4.13. Holding the T-bar to prevent the 3-D H machine from sliding forward on the seat cushion, proceed as follows:
- (a) return the back pan to the seat-back;
 - (b) alternately apply and release a horizontal rearward load, not to exceed 25 N, to the back angle bar at a height approximately at the centre of the torso weights until the hip angle quadrant indicates that a stable position has been reached after load release. Care shall be exercised to ensure that no exterior downward or lateral loads are applied to the 3-D H machine. If another level adjustment of the 3-D H machine is necessary, rotate the back pan forward, re-level, and repeat the procedure from paragraph 4.12.
- 4.14. Take all measurements:
- 4.14.1. The coordinates of the 'H' point are measured with respect to the three-dimensional reference system.
 - 4.14.2. The actual torso angle is read at the back angle quadrant of the 3-D H machine with the probe in its fully rearward position.
- 4.15. If a re-run of the installation of the 3-D H machine is desired, the seat assembly should remain unloaded for a minimum period of 30 min. prior to the re-run. The 3-D H machine should not be left loaded on the seat assembly longer than the time required to perform the test.
- 4.16. If the seats in the same row can be regarded as similar (bench seat, identical seats, etc.) only one 'H' point and one 'actual torso angle' shall be determined for each row of seats, the 3-D H machine described in Appendix 1 to this Annex being seated in a place regarded as representative for the row. This place shall be:
- 4.16.1. in the case of the front row, the driver's seat;
 - 4.16.2. in the case of the rear row or rows, an outer seat.
-

Appendix 1

Description of the three dimensional 'H' point machine⁽¹⁾ (3-D H machine)**1. Back and seat pans**

The back and seat pans are constructed of reinforced plastic and metal; they simulate the human torso and thigh and are mechanically hinged at the 'H' point. A quadrant is fastened to the probe hinged at the 'H' point to measure the actual torso angle. An adjustable thigh bar, attached to the seat pan, establishes the thigh centre line and serves as a baseline for the hip angle quadrant.

2. Body and leg elements

Lower leg segments are connected to the seat pan assembly at the T-bar joining the knees, which is a lateral extension of the adjustable thigh bar. Quadrants are incorporated in the lower leg segments to measure knee angles. Shoe and foot assemblies are calibrated to measure the foot angle. Two spirit levels orient the device in space. Body element weights are placed at the corresponding centres of gravity to provide seat penetration equivalent to a 76 kg male. All joints of the 3-D H machine should be checked for free movement without encountering noticeable friction.

Figure 1

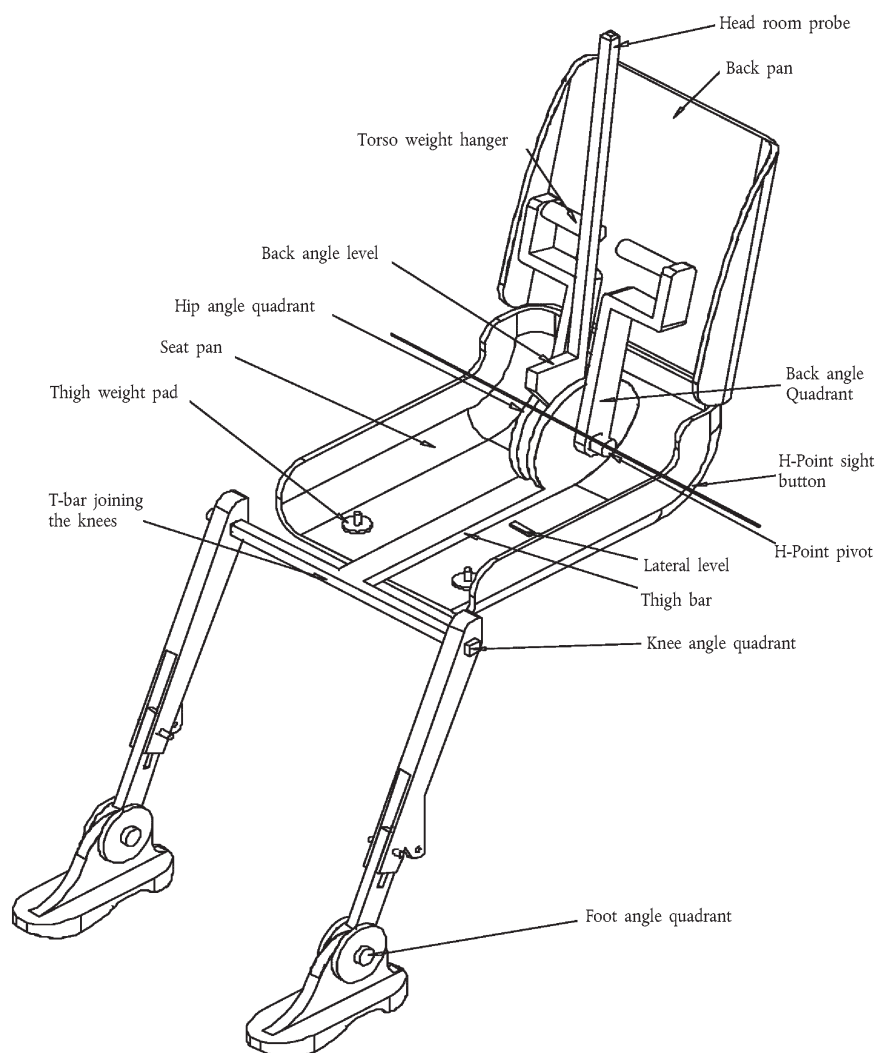
3-D H machine elements designation

⁽¹⁾ For details of the construction of the 3-D H machine refer to Society of Automobile Engineers (SAE), 400 Commonwealth Drive, Warrendale, Pennsylvania 15096, United States of America.
The machine corresponds to that described in ISO Standard 6549-1980.

Figure 2
Dimensions of the 3-D H machine elements and load distribution

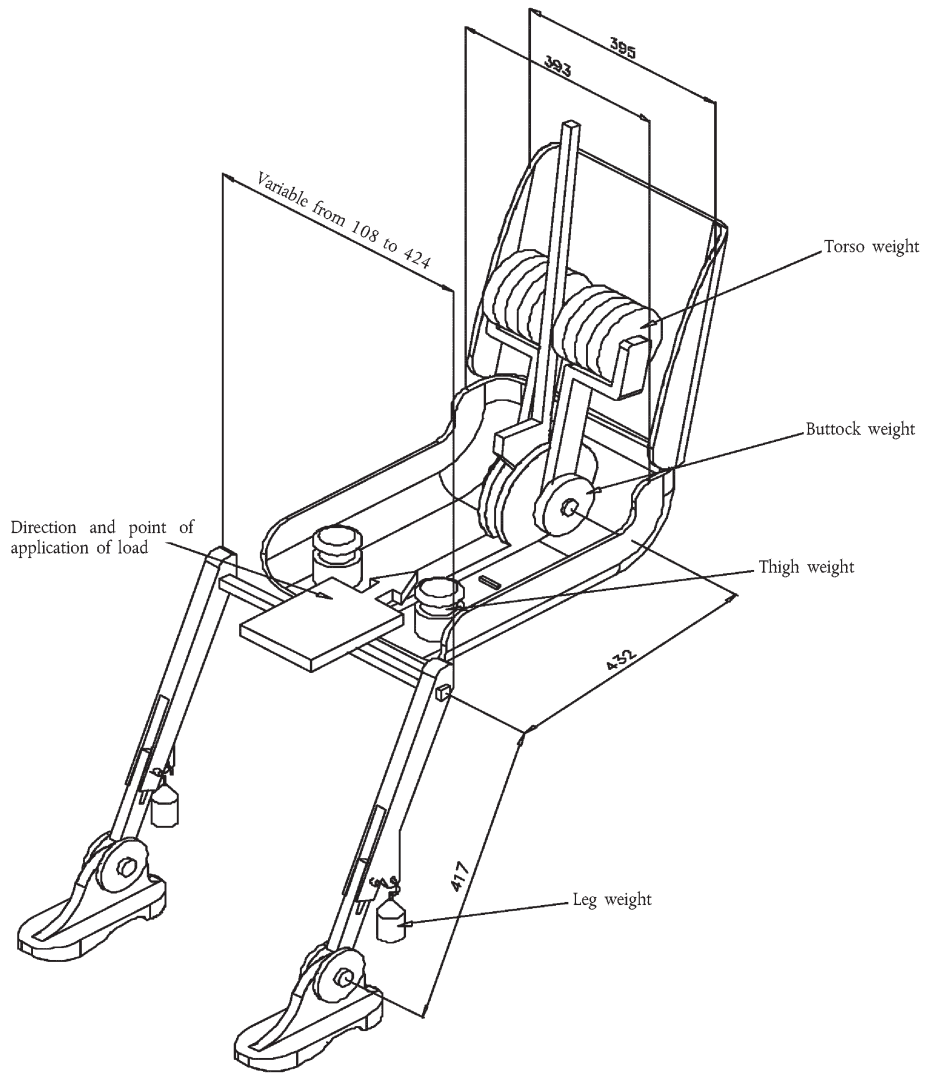

—

Appendix 2

Three-dimensional reference system

1. The three-dimensional reference system is defined by three orthogonal planes established by the vehicle manufacturer (see figure) ⁽¹⁾.
2. The vehicle measuring attitude is established by positioning the vehicle on the supporting surface such that the coordinates of the fiducial marks correspond to the values indicated by the manufacturer.
3. The coordinates of the 'R' point and the 'H' point are established in relation to the fiducial marks defined by the vehicle manufacturer.

Figure

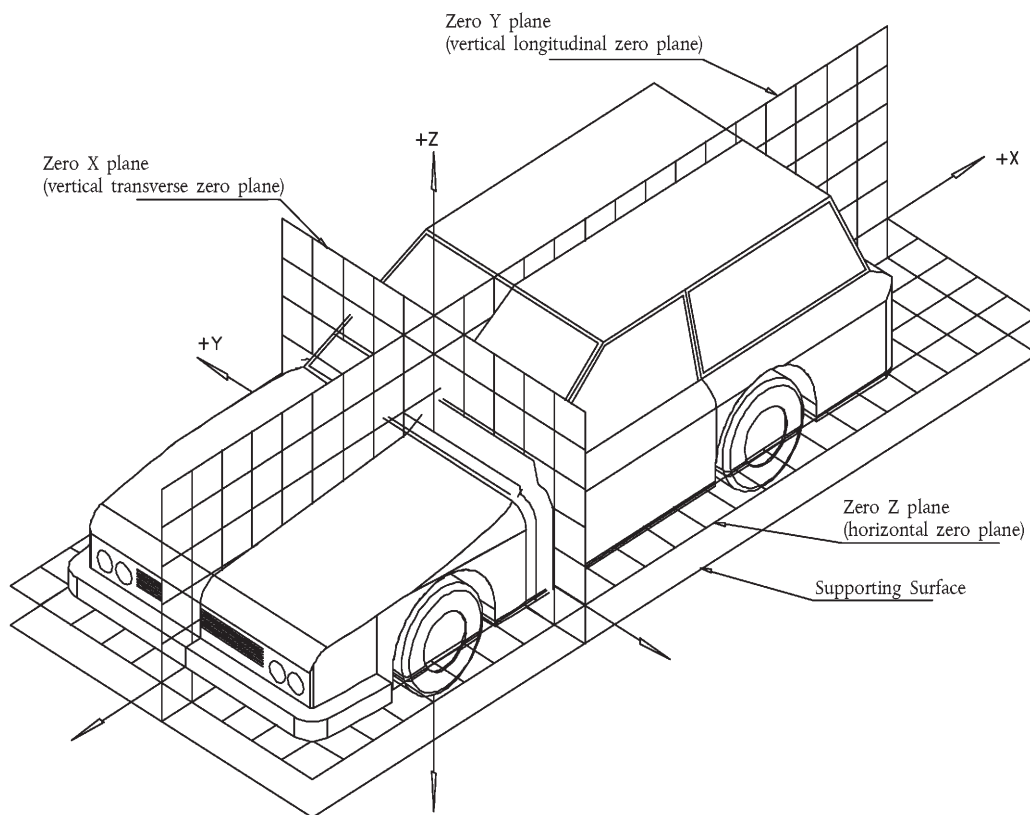
Three-dimensional reference system

⁽¹⁾ The reference system corresponds to ISO standard 4130, 1978.

Appendix 3

Reference data concerning seating positions

1. Coding of reference data

Reference data are listed consecutively for each seating position. Seating positions are identified by a two-digit code. The first digit is an Arabic numeral and designates the row of seats, counting from the front to the rear of the vehicle. The second digit is a capital letter which designates the location of the seating position in a row, as viewed in the direction of forward motion of the vehicle; the following letters shall be used:

- L = left
- C = centre
- R = right

2. Description of vehicle measuring attitude:

2.1. Coordinates of fiducial marks

- X
- Y
- Z

3. List of reference data:

3.1. Seating position:

3.1.1. Coordinates of 'R' point

- X
- Y
- Z

3.1.2. Design torso angle:

3.1.3. Specifications for seat adjustment ⁽¹⁾:

- horizontal:
- vertical:
- angular:
- torso angle:

Note: List reference data for further seating positions under 3.2, 3.3, etc.

⁽¹⁾ Strike out what does not apply.

III

(Acts adopted under the EU Treaty)

ACTS ADOPTED UNDER TITLE V OF THE EU TREATY

COUNCIL JOINT ACTION 2008/487/CFSP

of 23 June 2008

in support of the universalisation and implementation of the 1997 Convention on the Prohibition of the Use, Stockpiling, Production and Transfer of Anti-Personnel Mines and on their Destruction, in the framework of the European Security Strategy

THE COUNCIL OF THE EUROPEAN UNION,

Having regard to the Treaty on European Union, and in particular Article 14 thereof,

Whereas:

- (1) On 12 December 2003, the European Council adopted the European Security Strategy, which calls for an international order based on effective multilateralism. The European Security Strategy acknowledges the United Nations Charter as the fundamental framework for international relations. Strengthening the United Nations and helping to equip it to fulfil its responsibilities and to act effectively is a priority of the European Union.
- (2) United Nations General Assembly Resolution 51/45 of 10 December 1996 urged all States to pursue vigorously an effective, legally binding international agreement to ban the use, stockpiling, production and transfer of anti-personnel landmines.
- (3) The Convention on the Prohibition of the Use, Stockpiling, Production and Transfer of Anti-Personnel Mines and on their Destruction ('the Convention') was opened for signature on 3 December 1997 and entered into force on 1 March 1999. It constitutes a comprehensive international instrument to deal with all matters related to anti-personnel landmines, including their use, production and trade, victim assistance, mine clearance and stockpile destruction.
- (4) In December 2004, the States Parties to the Convention adopted the Nairobi Action Plan 2005-2009 and agreed to various understandings regarding the universalisation and implementation of the Convention in all its aspects.

- (5) In December 2007, the United Nations General Assembly adopted Resolution 62/41 on the implementation of the Convention, inviting all States that have not signed it to accede without delay, urging all States that have signed but not ratified the Convention to ratify it without delay and urging all States, where in a position to do so, to promote adherence to the Convention through bilateral, sub-regional, regional and multilateral contacts, outreach, seminars and other means,

HAS ADOPTED THIS JOINT ACTION:

Article 1

1. With a view to supporting the implementation of the Convention on the Prohibition of the Use, Stockpiling, Production and Transfer of Anti-Personnel Mines and on their Destruction (the Convention) in line with United Nations General Assembly Resolution 62/41, the European Union (EU) shall pursue the following objectives:
 - (a) promotion of the universalisation of the Convention and support for the preparation of the Second Review Conference of the Convention in 2009;
 - (b) support for full implementation of the Convention by States Parties.
2. In order to achieve the objectives referred to in paragraph 1, the EU shall undertake the following projects:
 - (a) organisation of up to six regional or sub-regional seminars aimed at increasing accession to and ratification of the Convention and preparing for the second Review Conference in 2009;

- (b) provision of continuous technical advice and up to 25 targeted technical assistance visits to States Parties with a view to making recommendations on the full implementation of the Convention.

A detailed description of these projects is set out in the Annex.

Article 2

1. The Presidency, assisted by the Secretary-General of the Council/High Representative for the CFSP (SG/HR), shall be responsible for the implementation of this Joint Action. The Commission shall be fully associated.
2. The technical implementation of the projects referred to in Article 1(2) shall be carried out by the Implementation Support Unit of the Geneva International Centre for Humanitarian Demining (ISU/GICHD). It shall perform this task under the control of the SG/HR, assisting the Presidency. For this purpose, the SG/HR shall enter into the necessary arrangements with the ISU/GICHD.
3. The Presidency, the SG/HR and the Commission shall keep each other regularly informed about the projects, in accordance with their respective competences.

Article 3

1. The financial reference amount for the implementation of the projects referred to in Article 1(2) shall be EUR 1 070 000, to be funded from the general budget of the European Union.
2. The expenditure financed by the amount stipulated in paragraph 1 shall be managed in accordance with the procedures and rules applicable to the general budget of the European Union.
3. The Commission shall supervise the proper management of the expenditure referred to in paragraph 2, which shall take the form of a grant. For this purpose, it shall conclude a financing agreement with the GICHD. The financing

agreement shall stipulate that the ISU/GICHD is to ensure visibility of the EU contribution, appropriate to its size.

4. The Commission shall endeavour to conclude the financing agreement referred to in paragraph 3 as soon as possible after the entry into force of this Joint Action. It shall inform the Council of any difficulties in that process and of the date of conclusion of the financing agreement.

Article 4

The Presidency, assisted by the SG/HR, shall report to the Council on the implementation of this Joint Action on the basis of regular reports prepared by the ISU/GICHD. These reports shall form the basis for the evaluation by the Council. The Commission shall be fully associated. It shall provide information on the financial aspects of the implementation of this Joint Action.

Article 5

This Joint Action shall enter into force on the date of its adoption.

It shall expire 21 months after the date of conclusion of the financing agreement referred to in Article 3(3) or six months after the date of its adoption if no financing agreement has been concluded within that period.

Article 6

This Joint Action shall be published in the *Official Journal of the European Union*.

Done at Luxembourg, 23 June 2008.

For the Council
The President
I. JARC

ANNEX

1. Objectives

The overall objectives of this Joint Action are the promotion of the universalisation of the Convention, support for full implementation of the Convention by States Parties and support for the preparations for the Second Review Conference which will take place in 2009. Maximum synergy will be ensured with other relevant EU financial instruments.

2. Projects**2.1. Promotion of the universalisation and implementation of the Convention on the Prohibition of the Use, Stock-piling, Production and Transfer of Anti-Personnel Mines and on their Destruction, and preparation of the 2009 Review Conference.****2.1.1. Project objective**

To promote adherence to the Convention through regional and sub-regional seminars and to support the preparations for the Second Review Conference.

2.1.2. Project description

Up to six regional or sub-regional workshops will be organised to prepare for the Second Review Conference and to encourage further universalisation of the Convention.

2.1.3. Project results

Increased membership of the Convention and renewed global interest in the importance of the objectives of and the obligations resulting from ratification of the Convention, as well as a better understanding of the needs of future States Parties concerning anti-personnel landmine programmes.

Better preparation of the Second Review Conference which will take place in 2009, through enhanced regional input and networking.

2.1.4. Seminar venues

The ISU/GICHD will present a list of potential venues for the regional seminars which will then be endorsed by the Presidency, assisted by the SG/HR in consultation with the competent Council bodies.

The criteria used for choosing the venues for the seminars will include the willingness and commitment of a relevant State in a particular region to host a seminar, the level of commitment to the Convention by States in the region and, if relevant, the commitment of a relevant regional or sub-regional organisation.

2.1.5. Project beneficiaries

States party and not party to the Convention in the regions where the seminars will be organised.

2.2. Support for the full implementation of the Convention**2.2.1. Project objective**

To assist States Parties in implementing the provisions of the Convention.

2.2.2. Project description

To assist States Parties to the Convention which are in the process of fulfilling their obligations resulting from it.

Technical assistance visits will be organised to States Parties with a view to assessing the national response to the obligations resulting from the Convention and to providing support in line with other relevant ongoing programmes and/or activities, the findings of the Nairobi Summit and the findings of the annual progress reports.

2.2.3. Project results

— Enhanced knowledge of the implementation efforts made at national level which may lead to further action by the EU,

- provision of advice and recommendations on technical requirements necessary to fulfil obligations under the Convention,
- development of relevant national plans in line with obligations under the Convention.

2.2.4. Project beneficiaries

States Parties will be invited to request assistance. A decision will be made on the basis of the degree to which requesting States Parties have compiled the necessary background information prior to engagement, taken meaningful steps to support a visit by technical experts and shown readiness to make full use of the information acquired as a result of the exercise.

The selection of beneficiaries will take into account the respecting of the commitments made by potential beneficiaries in the area of demining and stockpile destruction in the framework of the deadlines established at the Convention meetings.

The ISU/GICHD will present a final list of beneficiaries which will then be endorsed by the Presidency, assisted by the SG/HR in consultation with the competent Council bodies.

3. **Duration**

The total duration for the implementation of this Joint Action is 21 months.

4. **Implementing entity**

The Presidency, assisted by the SG/HR, is responsible for the implementation and supervision of this Joint Action. The Presidency will entrust the technical implementation to ISU/GICHD.

The ISU/GICHD will ensure the visibility of the EU contribution, appropriate to its size.

5. **Reporting**

The ISU/GICHD will prepare detailed reports following each of the planned seminars and the technical assistance visits.
