

Official Journal

of the European Union

L 84

Volume 51

26 March 2008

English edition

Legislation

Contents II Acts adopted under the EC Treaty/Euratom Treaty whose publication is not obligatory

DECISIONS

Commission

2008/231/CE:

- ★ **Commission Decision of 1 February 2008 concerning the technical specification of interoperability relating to the operation subsystem of the trans-European high-speed rail system adopted referred to in Article 6(1) of Council Directive 96/48/EC and repealing Commission Decision 2002/734/EC of 30 May 2002 (notified under document number C(2008) 356) ⁽¹⁾ 1**

2008/232/CE:

- ★ **Commission Decision of 21 February 2008 concerning a technical specification for interoperability relating to the 'rolling stock' sub-system of the trans-European high-speed rail system (notified under document number C(2008) 648) ⁽¹⁾ 132**

Corrigenda

- ★ **Corrigendum to the Guideline of the European Central Bank of 1 August 2007 on monetary, financial institutions and markets statistics (recast) (ECB/2007/9) (OJ L 341, 27.12.2007) 393**

⁽¹⁾ Text with EEA relevance

Price: EUR 58



Acts whose titles are printed in light type are those relating to day-to-day management of agricultural matters, and are generally valid for a limited period.

The titles of all other acts are printed in bold type and preceded by an asterisk.

II

(Acts adopted under the EC Treaty/Euratom Treaty whose publication is not obligatory)

DECISIONS

COMMISSION

COMMISSION DECISION

of 1 February 2008

concerning the technical specification of interoperability relating to the operation subsystem of the trans-European high-speed rail system adopted referred to in Article 6(1) of Council Directive 96/48/EC and repealing Commission Decision 2002/734/EC of 30 May 2002

(notified under document number C(2008) 356)

(Text with EEA relevance)

(2008/231/CE)

THE COMMISSION OF THE EUROPEAN COMMUNITIES,

Having regard to the Treaty establishing the European Community,

Having regard to Council Directive 96/48/EC of 23 July 1996 on the interoperability of the trans-European high-speed rail system ⁽¹⁾, and in particular Articles 6 (1) and 6(2) thereof,

Whereas:

- (1) In accordance with Article 6(2) of Directive 96/48/EC as modified by Directive 2004/50/EC ⁽²⁾, amendments to technical specifications for interoperability (TSIs) are drafted by the European Railway Agency (ERA) under a mandate of the Commission.
- (2) The TSI attached to this Decision was drafted by the Joint Representative Body under a mandate delivered in 2001, in accordance with Article 6(1) of Directive 96/48/EC before entry into force of Directive 2004/50/EC. The European Association for Railway Interoperability (AEIF) was appointed as the joint representative body.
- (3) The draft TSI was accompanied by a presentation report containing a cost-benefit analysis as provided for in Article 6(5) of Directive 96/48/EC.

(4) The draft TSI has been examined by the Committee set up by Directive 96/48/EC on the interoperability of the trans-European high-speed rail system in the light of the presentation report.

(5) In its current version the TSI does not fully deal with all essential requirements. In accordance with Article 17 of Directive 96/48/EC as modified by Directive 2004/50/EC, technical aspects which are not covered are identified as 'Open Points' in Annex U of this TSI.

(6) In accordance with Article 17 of Directive 96/48/EC as modified by Directive 2004/50/EC, individual Member States are to inform the other Member States and the Commission of the relevant national technical rules in use for implementing essential requirements related to these 'open points', as well as of the bodies it appoints for carrying out the procedure for the assessment of conformity or suitability for use and the checking procedure in use for verifying the interoperability of subsystems within the meaning of Article 16(2) of Directive 96/48/EC. For this latter purpose, Member States should apply, as far as possible, the principles and criteria provided for in Directive 96/48/EC and make use of the bodies notified under Article 20 of Directive 96/48/EC. The Commission should carry out an analysis of the information forwarded by the Member States, in the form of national rules, procedures, bodies in charge of implementing procedures, and duration of these procedures, and, where appropriate, should discuss with the Committee the need for the adoption of any measures.

⁽¹⁾ OJ L 235, 17.9.1996, p. 6. Directive as last amended by Directive 2007/32/EC (OJ L 141, 2.6.2007, p. 63).

⁽²⁾ OJ L 164, 30.4.2004, p. 114

- (7) The TSI in question should not demand the use of specific technologies or technical solutions except where this is strictly necessary for the interoperability of the trans-European high-speed rail system.
- (8) The TSI is based on best available expert knowledge at the time of preparation of the relevant draft. Developments in technology, operational, safety or social requirements may make it necessary to amend or supplement this TSI. Where applicable, a review or updating procedure should be initiated in accordance with Article 6(3) of Directive 96/48/EC.
- (9) To encourage innovation and in order to take into account the experience acquired, the attached TSI should be subject to a periodical revision at regular intervals.
- (10) Where innovative solutions are proposed the manufacturer or the contracting entity shall state the deviation from the relevant section of the TSI. The European Rail Agency will finalise the appropriate functional and interface specifications of the solution and develop the assessment methods.
- (11) Implementation of the attached TSI and conformity with the relevant sections of the TSI must be determined in accordance with an implementation plan that shall be drawn up by each Member State for the lines for which it is responsible. The Commission should carry out an analysis of the information forwarded by the Member States and, where appropriate, should discuss with the Committee the need for the adoption of any further measures.
- (12) Rail traffic currently operates under existing national, bilateral, multinational or international agreements. It is important that those agreements do not hinder current and future progress towards interoperability. To this end, it is necessary that the Commission examine those agreements in order to determine whether the TSI presented in this Decision needs to be revised accordingly.
- (13) The provisions of this Decision are in conformity with the opinion of the Committee set up by Article 21 of Council Directive 96/48/EC,

HAS ADOPTED THIS DECISION:

Article 1

A revised version of Technical Specification for Interoperability ('TSI') relating to the 'traffic operation and management' subsystem of the trans-European high-speed rail system referred to in Article 6(1) of Directive 96/48/EC is hereby adopted by the Commission.

The TSI shall be as set out in the Annex to this Decision.

The TSI shall be applicable to the traffic operation and management subsystem as defined in Annex II to Directive 96/48/EC.

Article 2

1. With regard to those issues classified as 'Open points' set out in Annex U of the TSI, the conditions to be complied with for the verification of the interoperability pursuant to Article 16(2) of Directive 96/48/EC shall be those applicable technical rules in use in the Member State which authorise the placing in service of the subsystem covered by this Decision.

2. Each Member State shall notify to the other Member States and to the Commission within six months of the notification of this Decision:

- (a) the list of the applicable technical rules mentioned in paragraph 1;
- (b) the conformity assessment and checking procedures to be applied with regard to the application of these rules;
- (c) the bodies it appoints for carrying out those conformity-assessment and checking procedures.

Article 3

Member States shall notify the following types of agreement to the Commission within six months of the entry into force of the attached TSI:

- (a) national, bilateral or multilateral agreements between Member States and Railway Undertaking(s) or Infrastructure Manager(s), agreed on either a permanent or a temporary basis and required due to the very specific or local nature of the intended train service;
- (b) bilateral or multilateral agreements between Railway Undertaking(s), Infrastructure Manager(s) or Member State(s) which deliver significant levels of local or regional interoperability;
- (c) international agreements between one or more Member State(s) and at least one third country, or between Railway Undertaking(s) or Infrastructure Manager(s) of Member States and at least one Railway Undertaking or Infrastructure Manager of a third country, which deliver significant levels of local or regional interoperability.

Article 4

Member States shall establish a national implementation plan of the TSI in accordance with the criteria specified in Chapter 7 of the Annex.

They shall forward this implementation plan to the other Member States and the Commission not later than one year after the date on which this Decision becomes applicable.

Article 5

Commission Decision 2002/734/EC ⁽¹⁾ shall no longer apply as from the date on which this Decision becomes applicable.

Article 6

This Decision shall apply from 1 September 2008.

Article 7

This Decision is addressed to the Member States.

Done at Brussels, 1 February 2008.

For the Commission
Jacques BARROT
Vice-President

⁽¹⁾ JO L 245, 12.9.2002, p. 370.

ANNEX

**DIRECTIVE 96/48/EC — INTEROPERABILITY OF THE TRANS-EUROPEAN
HIGH SPEED RAIL SYSTEM**

TECHNICAL SPECIFICATION FOR INTEROPERABILITY

‘Operations and traffic management’ Sub-System

1.	INTRODUCTION	10
1.1.	Technical scope	10
1.2.	Geographical scope	10
1.3.	Content of this TSI	10
2.	DEFINITION OF SUBSYSTEM/SCOPE	11
2.1.	Subsystem	11
2.2.	Scope	11
2.2.1.	Staff and trains	11
2.2.2.	Operating principles	12
2.2.3.	Applicability to existing vehicles and infrastructure	12
2.3.	Link between this TSI and Directive 2004/49/EC	12
3.	ESSENTIAL REQUIREMENTS	13
3.1.	Compliance with the essential requirements	13
3.2.	Essential requirements — overview	13
3.3.	Specific aspects in relation to these requirements	13
3.3.1.	Safety	13
3.3.2.	Reliability and availability	14
3.3.3.	Health	14
3.3.4.	Environmental protection	14
3.3.5.	Technical compatibility	15
3.4.	Aspects relating specifically to the Traffic Operation and Management subsystem	15
3.4.1.	Safety	15
3.4.2.	Reliability and availability	16
3.4.3.	Technical compatibility	16
4.	CHARACTERISTICS OF THE SUB-SYSTEM	17
4.1.	Introduction	17
4.2.	Functional and technical specifications of the sub-system	17
4.2.1.	Specifications relating to staff	17
4.2.1.1.	General requirements	17
4.2.1.2.	Documentation for drivers	18
4.2.1.2.1.	Rule Book	18
4.2.1.2.2.	Description of the line and the relevant lineside equipment associated with the lines worked over	19
4.2.1.2.2.1.	Preparation of the Route Book	19

4.2.1.2.2.2.	Modified elements	20
4.2.1.2.2.3.	Informing the driver in real time	20
4.2.1.2.3.	Timetables	20
4.2.1.2.4.	Rolling stock	21
4.2.1.3.	Documentation for Railway Undertaking staff other than drivers	21
4.2.1.4.	Documentation for Infrastructure Manager's staff authorising train movements	21
4.2.1.5.	Safety-related communications between traincrew, other Railway Undertaking staff and staff authorising train movements	21
4.2.2.	Specifications relating to trains	21
4.2.2.1.	Train visibility	21
4.2.2.1.1.	General requirement	21
4.2.2.1.2.	Front end	21
4.2.2.2.	Train audibility	22
4.2.2.2.1.	General requirement	22
4.2.2.2.2.	Control	22
4.2.2.3.	Vehicle identification	22
4.2.2.4.	Requirements for Passenger vehicles	22
4.2.2.5.	Train composition	22
4.2.2.6.	Train braking	23
4.2.2.6.1.	Minimum requirements of the braking system	23
4.2.2.6.2.	Brake performance	23
4.2.2.7.	Ensuring that the train is in running order	23
4.2.2.7.1.	General requirement	23
4.2.2.7.2.	Data required	24
4.2.3.	Specifications relating to train operations	24
4.2.3.1.	Train planning	24
4.2.3.2.	Identification of trains	24
4.2.3.3.	Train departure	24
4.2.3.3.1.	Checks and tests before departure	24
4.2.3.3.2.	Informing the Infrastructure Manager of the train's operational status	24
4.2.3.4.	Traffic management	24
4.2.3.4.1.	General requirements	24
4.2.3.4.2.	Train reporting	25
4.2.3.4.2.1.	Data required for train position reporting	25
4.2.3.4.2.2.	Predicted hand over time	25
4.2.3.4.3.	Dangerous goods	25
4.2.3.4.4.	Operational quality	25
4.2.3.5.	Data recording	26
4.2.3.5.1.	Recording of supervision data outside the train	26

4.2.3.5.2.	Recording of supervision data on-board the train	27
4.2.3.6.	Degraded operation	27
4.2.3.6.1.	Advice to other users	27
4.2.3.6.2.	Advice to train drivers	27
4.2.3.6.3.	Contingency arrangements	27
4.2.3.7.	Managing an emergency situation	28
4.2.3.8.	Aid to traincrew in the event of an incident or of a major rolling stock malfunction	28
4.3.	Functional and technical specifications of the interfaces	28
4.3.1.	Interfaces with the Infrastructure TSI	28
4.3.1.1.	Signal Sighting	28
4.3.1.2.	Passenger Vehicles	29
4.3.1.3.	Professional Competences	29
4.3.2.	Interfaces with the Control/Command and Signalling TSI	29
4.3.2.1.	Recording of supervision data	29
4.3.2.2.	Driver vigilance	29
4.3.2.3.	ERTMS/ETCS and ERTMS/GSM-R operating rules	29
4.3.2.4.	Signal and lineside marker sighting	29
4.3.2.5.	Train braking	30
4.3.2.6.	Use of sanding. Minimum elements relevant to professional competences for the task of driving a train	30
4.3.2.7.	Data recording and hot axle box detection	30
4.3.3.	Interfaces with the Rolling Stock TSI	30
4.3.3.1.	Braking	30
4.3.3.2.	Requirements for passenger vehicles	30
4.3.3.3.	Train visibility	30
4.3.3.3.1.	On the leading vehicle of a train facing in the direction of travel	30
4.3.3.3.2.	On the rear end	31
4.3.3.4.	Train audibility	31
4.3.3.5.	Signal sighting	31
4.3.3.6.	Driver vigilance	31
4.3.3.7.	Train composition and annex B	31
4.3.3.8.	Rolling Stock parameters which influence ground-based train monitoring systems and rolling stock dynamic behaviour	31
4.3.3.9.	Sanding	32
4.3.3.10.	Train composition, annexes H and J	32
4.3.3.11.	Contingency arrangements and Managing an emergency situation	32
4.3.3.12.	Data recording	32
4.3.3.13.	Aerodynamic effects on ballast	32
4.3.3.14.	Environmental conditions	32

4.3.3.15.	Crosswinds	32
4.3.3.16.	Maximum pressure variations in tunnels	32
4.3.3.17.	Exterior noise	32
4.3.3.18.	Fire safety	32
4.3.3.19.	Lifting/rescue procedures	32
4.3.3.20.	Monitoring and diagnostic concepts	32
4.3.3.21.	Particular specification for long tunnels	32
4.3.3.22.	Traction performance requirements	33
4.3.3.23.	Traction adhesion requirements	33
4.3.3.24.	Functional and technical specification related to power supply	33
4.3.4.	Interfaces with the HS Energy TSI	33
4.3.5.	Interfaces with the Safety in Rail Tunnels TSI	33
4.3.6.	Interfaces with the Persons with Reduced Mobility TSI	33
4.4.	Operating rules	33
4.5.	Maintenance rules	33
4.6.	Professional competences	34
4.6.1.	Professional competence	34
4.6.1.1.	Professional knowledge	34
4.6.1.2.	Ability to put this knowledge into practice	34
4.6.2.	Linguistic competence	34
4.6.2.1.	Principles	34
4.6.2.2.	Level of knowledge	35
4.6.3.	Initial and ongoing assessment of staff	35
4.6.3.1.	Basic elements	35
4.6.3.2.	Analysis of training needs	36
4.6.3.2.1.	Development of the analysis of training needs	36
4.6.3.2.2.	Updating the analysis of training needs	36
4.6.3.2.3.	Specific elements for traincrew and auxiliary staff	36
4.6.3.2.3.1.	Route knowledge	36
4.6.3.2.3.2.	Knowledge of rolling stock	36
4.6.3.2.3.3.	Auxiliary Staff	37
4.7.	Health and Safety Conditions	37
4.7.1.	Introduction	37
4.7.2.	Recommended criteria for approval of occupational doctors and medical organisations	37
4.7.3.	Criteria for approval of psychologists involved in psychological assessment and psychological assessment requirements	37
4.7.3.1.	Certification of psychologists	37
4.7.3.2.	Content and interpretation of psychological assessment	37
4.7.3.3.	Selection of assessment tools	38
4.7.4.	Medical examinations and psychological assessments	38
4.7.4.1.	Before appointment	38

4.7.4.1.1.	Minimum content of the medical examination	38
4.7.4.1.2.	Psychological assessment	38
4.7.4.2.	After appointment	39
4.7.4.2.1.	Periodicity of periodic medical examinations	39
4.7.4.2.2.	Minimum content of the periodic medical examination	39
4.7.4.2.3.	Additional medical examinations and/or psychological assessments	39
4.7.5.	Medical requirements	39
4.7.5.1.	General requirements	39
4.7.5.2.	Vision requirements	40
4.7.5.3.	Hearing requirements	40
4.7.5.4.	Pregnancy	40
4.7.6.	Specific requirements regarding the task of driving a train	40
4.7.6.1.	Periodicity of periodic medical examinations	40
4.7.6.2.	Additional content of medical examination	41
4.7.6.3.	Additional vision requirements	41
4.7.6.4.	Additional hearing and speaking requirements	41
4.7.6.5.	Anthropometrics	41
4.7.6.6.	Trauma Counselling	41
4.8.	Infrastructure and Rolling stock registers	41
4.8.1.	Infrastructure	41
4.8.2.	Rolling stock	42
5.	INTEROPERABILITY CONSTITUENTS	42
5.1.	Definition	42
5.2.	List of constituents	42
5.3.	Constituents' performances and specifications	42
6.	ASSESSMENT OF CONFORMITY AND/OR SUITABILITY FOR USE OF THE CONSTITUENTS AND VERIFICATION OF THE SUBSYSTEM	42
6.1.	Interoperability constituents	42
6.2.	Traffic Operation and Management Subsystem	42
6.2.1.	Principles	42
6.2.2.	Rules and procedures documentation	43
6.2.3.	Assessment procedure	43
6.2.3.1.	Decision by Competent Authority	43
6.2.3.2.	If an assessment is required	43
6.2.4.	System performance	44
7.	IMPLEMENTATION	44
7.1.	Principles	44
7.2.	Implementation guidelines	45
7.3.	Specific cases	46
7.3.1.	Introduction	46
7.3.2.	List of specific cases	46

ANNEX A:	ERTMS/ETCS AND ERTMS/GSM-R OPERATING RULES	47
ANNEX B:	OTHER RULES ENABLING A COHERENT OPERATION OF NEW STRUCTURAL SUBSYSTEMS	48
	A. GENERAL	48
	B. STAFF SAFETY AND SECURITY	48
	C. OPERATIONAL INTERFACE WITH SIGNALLING AND COMMAND AND CONTROL EQUIPMENT	48
	D. TRAIN MOVEMENTS	48
	E. ANOMALIES, INCIDENTS AND ACCIDENTS	48
ANNEX C:	SAFETY RELATED COMMUNICATIONS METHODOLOGY	49
ANNEX D:	INFORMATION TO WHICH THE RAILWAY UNDERTAKING MUST HAVE ACCESS IN CONNECTION WITH THE ROUTE(S) OVER WHICH HE INTENDS TO OPERATE	60
ANNEX E:	LANGUAGE AND COMMUNICATION LEVEL	65
ANNEX F:	INFORMATIVE AND NOT MANDATORY TRAFFIC OPERATION AND MANAGEMENT SUBSYSTEM ASSESSMENT GUIDELINES	66
ANNEX G:	INFORMATIVE AND NOT MANDATORY LIST OF ELEMENTS TO BE VERIFIED FOR EACH BASIC PARAMETER	68
ANNEX H:	MINIMUM ELEMENTS RELEVANT TO PROFESSIONAL COMPETENCE FOR THE TASK OF DRIVING A TRAIN	72
ANNEX I:	NOT USED	75
ANNEX J:	MINIMUM ELEMENTS RELEVANT TO PROFESSIONAL COMPETENCE FOR THE TASKS ASSOCIATED WITH 'ACCOMPANYING TRAINS'	75
ANNEX K:	NOT USED	77
ANNEX L:	MINIMUM ELEMENTS RELEVANT TO PROFESSIONAL COMPETENCE FOR THE TASK OF PREPAR- ING TRAINS	77
ANNEX M:	NOT USED	79
ANNEX N:	INFORMATIVE AND NOT MANDATORY IMPLEMENTATION GUIDELINES	79
ANNEX O:	NOT USED	83
ANNEX P:	VEHICLE IDENTIFICATION	84
ANNEX Q:	NOT USED	126
ANNEX R:	TRAIN IDENTIFICATION	126
ANNEX S:	NOT USED	126
ANNEX T:	BRAKE PERFORMANCE	127
ANNEX U:	LIST OF OPEN POINTS	127
ANNEX V:	PREPARATION AND UPDATING RULES DOCUMENTATION FOR DRIVERS	128
GLOSSARY	129

1. INTRODUCTION

1.1. Technical scope

This TSI concerns the Traffic Operation and Management subsystem which is one of the subsystems listed in Annex II (1) to Directive 96/48/EC as modified by Directive 2004/50/EC and its maintenance.

This TSI is applicable to the following classes of trains, regardless of whether the trains consist of fixed formation trainsets (indivisible in service), or individual vehicles. It applies equally to passenger and/or non-passenger carrying vehicles:

- class 1: Trains having a maximum speed of at least 250 km/h,
- class 2: Trains having a maximum speed of at least 190 km/h, but less than 250 km/h.

According to Annex I of the Directive, the specifications are defined for each of the following categories of line:

- category I: specially built high-speed lines equipped for speeds generally equal to or greater than 250 km/h,
- category II: specially upgraded high-speed lines equipped for speeds of the order of 200 km/h,
- category III: specially upgraded high-speed lines which have special features as a result of topographical, relief or town-planning constraints, on which the speed must be adapted to each case.]

1.2. Geographical scope

The geographical scope of this TSI is the trans-European high speed rail system as described in Annex I to Directive 96/48/EC as modified by Directive 2004/50/EC.

1.3. Content of this TSI

In accordance with Article 5(3) and Annex I (1) (b) of Directive 96/48/EC, as modified by Directive 2004/50/EC. In accordance with Article 5(3) of and with Annex I (1)(b) to Directive 96/48/EC, as modified by Directive 2004/50/EC, this TSI:

- (a) indicates its intended scope (chapter 2);
- (b) lays down essential requirements for the subsystem (chapter 3) and its interfaces vis-à-vis other subsystems (chapter 4);
- (c) establishes the functional and technical specifications to be met by the target subsystem and its interfaces vis-à-vis other subsystems (chapter 4);
- (d) determines the interoperability constituents and interfaces which must be covered by European specifications, including European standards, which are necessary to achieve interoperability within the trans-European high speed rail system (chapter 5);
- (e) states, in each case under consideration, which procedures are to be used in order to assess the conformity or the suitability for use of the interoperability constituents, on the one hand, or the EC verification of the subsystems, on the other hand (chapter 6);
- (f) indicates the strategy for implementing the TSI (chapter 7);
- (g) indicates, for the staff concerned, the professional competences and health and safety conditions at work required for the operation and maintenance of the subsystem, as well as for the implementation of the TSI.

Moreover, in accordance with Article 5(5), provision may be made for specific cases for each TSI; these are indicated in Chapter 7.

Lastly, this TSI also comprises, in Chapter 4, the operating and maintenance rules specific to the scope indicated in clauses 1.1 and 1.2 above.

2. DEFINITION OF SUBSYSTEM/SCOPE

2.1. Subsystem

The Traffic Operation and Management subsystem is one of the subsystems constituting the trans-European high speed rail system as listed in annex II to Directive 96/48/EC.

2.2. Scope

In conjunction with Annex I of directive 96/48/EC (as modified in Annex I of directive 2004/50/EC), the scope of this TSI applies to the Traffic Operation and Management subsystem of Infrastructure Managers and Railway Undertakings related to the operation of trains on the high speed rail TEN lines.

The specifications laid down in this TSI on Traffic Operation and Management may be used as a reference document for the operation of other trains running on the high speed rail TEN lines even though they are not covered by the scope of this TSI.

2.2.1. Staff and trains

It should be noted that Art 5.3 (g) of Dir. 96/48/EC as modified by Directive 2004/50/EC and Art 5.3 (g) of Dir. 2001/16/EC as modified by Directive 2004/50/EC are at variance in that the first speaks of 'professional competence' in respect to staff on the High Speed rail system, whilst 'professional qualification' is used in the second one in connection with the Conventional rail system.

To differentiate between the CR and HS OPE TSIs would not be appropriate and so the assumption has been made that the use of the term 'professional competence' covers the intention of the legislator.

Subsections 4.6 & 4.7 apply to those staff undertaking the safety critical tasks of driving a train and accompanying a train, when this involves crossing a border(s) between states and working beyond any location(s) designated as the 'frontier' in the Network Statement of an Infrastructure Manager and included in his safety authorisation.

A staff member will not be considered as crossing a border if the activity only involves working as far as any 'frontier' locations as described above.

For those staff undertaking the safety critical tasks of despatching trains and authorising train movements, mutual recognition of professional competences and health and safety conditions between Member States will apply.

For those staff undertaking the safety critical tasks associated with the last preparation of a train before it is scheduled to cross a border(s) and work beyond any 'frontier' location(s) as described above, Subsection 4.6 will apply with mutual recognition between Member States of health and safety conditions. A train will not be considered to be a cross border service, if all the vehicles of the train crossing the state border cross it only to the 'frontier' location(s) as described above.

This can be summarised in the tables below:

Staff involved with the working of trains that will cross-state borders *and proceed beyond the frontier location.*

Task	Professional Competences	Medical Requirements
Driving a Train and Accompanying a Train	4.6	4.7
Authorising Train movements	Mutual recognition	Mutual recognition
Ttrain Preparation	4.6	Mutual recognition
Train Despatch	Mutual recognition	Mutual recognition

Staff working trains that do not cross state borders *or do so as far as frontier locations*.

Task	Professional Competences	Medical Requirements
Driving a Train and Accompanying a Train	Mutual recognition	Mutual recognition
Authorising Train movements	Mutual recognition	Mutual recognition
Train Preparation	Mutual recognition	Mutual recognition
Train Despatch	Mutual recognition	Mutual recognition

In reading these tables it must be noted that the communications principles described in Chapter 4.2.1 are a mandatory requirement.

For cross border sections, agreements between neighbouring Infrastructure Managers or Member States referred in art. 7.1 describe:

- the safety rules to be applied between them concerning the protection of engineering worksites relating to the maintenance of the infrastructure subsystems concerned, and the content of the training of staff undertaking the safety critical tasks associated with the protection of these worksites,
- the safety rules to be applied between them concerning the operation and the protection of engineering worksites related to the maintenance of the fixed installations of the energy subsystems concerned, and the content of the training of staff undertaking the safety critical tasks associated with the operation and the protection of these installations.

2.2.2. Operating principles

The general objective of the present version of this TSI, which is the second one after the entry into force of Directive 96/48/EC but the first taking into account the modifications brought by Directive 2004/50/EC, is to enable a coherent operation of the structural subsystems intended to be used on the high speed network. In particular rules and procedures that are linked directly to the operation of a new train control and signalling system must be identical where identical situations exist.

Initially, this TSI has only covered those elements (as set out in Chapter 4) of the high speed rail 'Traffic Operation and Management' subsystem, where principally there are operational interfaces between Railway Undertakings and Infrastructure Managers or where there is a particular benefit to interoperability. In doing this, due consideration was given to the requirements of Directive 2004/49/EC (the Railway Safety Directive),

Subsequently, detailed operating rules for the European Train Control System (ETCS) and the Global System for Mobile communication — Railways (GSM-R) are specified in Annex A to this TSI.

2.2.3. Applicability to existing vehicles and infrastructure

While the majority of the requirements contained in this TSI relate to processes and procedures, a number also relate to physical elements, trains and vehicles which are important for operation.

The design criteria for these elements are described in the TSIs covering other subsystems such as rolling stock. In the context of the OPE TSI it is their operational function that is considered.

In such cases, it is recognised that modifying existing rolling stock/infrastructure facilities to meet the full requirements of this TSI may not be cost effective. The requirements concerned need therefore, only be applied to new elements or when the element is upgraded or renewed and requires new authorisation for placing into service within the meaning of Directive 96/48/EC Article 14.3.

2.3. Link between this TSI and Directive 2004/49/EC

Although this TSI is being developed under Interoperability Directive 96/48/EC (as amended by Directive 2004/50/EC), it addresses requirements closely related to the operational procedures and processes required from an Infrastructure Manager or Railway Undertaking when applying for a safety authorisation/certificate under the Safety Directive (2004/49/EC).

3. ESSENTIAL REQUIREMENTS

3.1. Compliance with the essential requirements

In accordance with Article 4(1) of Directive 96/48/EC, the trans-European high speed rail system, its subsystems and their interoperability constituents must meet the essential requirements set out in general terms in Annex III to the Directive.

3.2. Essential requirements — overview

The essential requirements cover:

- safety,
- reliability and availability,
- health,
- environmental protection,
- technical compatibility.

According to Directive 96/48/EC, the essential requirements may be generally applicable to the whole trans-European high speed rail system or be specific to each subsystem and its constituents.

3.3. Specific aspects in relation to these requirements

The relevance of the general requirements to the Traffic Operation and Management subsystem is determined in the following clauses.

3.3.1. Safety

In accordance with Annex III of Directive 96/48/EC, the safety-related essential requirements that apply to the Traffic Operation and Management subsystem are the following:

Essential requirement 1.1.1 of Annex III to Directive 96/48/EC:

'The design, construction or assembly, maintenance and monitoring of safety-critical components and, more particularly, of the components involved in train movements must be such as to guarantee safety at the level corresponding to the aims laid down for the network, including those for specific degraded situations.'

As far as the Traffic Operation and Management subsystem is concerned, this essential requirement is addressed by the specification of Subsection 'train visibility' (sub sections 4.2.2.1 and 4.3) and 'train audibility' in sub sections 4.2.2.2 and 4.3.

Essential requirement 1.1.2 of Annex III to Directive 96/48/EC:

'The parameters involved in the wheel/rail contact must meet the stability requirements needed in order to guarantee safe movement at the maximum authorised speed.'

This essential requirement is not relevant to the Traffic Operation and Management subsystem.

Essential requirement 1.1.3 of Annex III to Directive 96/48/EC:

'The components used must withstand any normal or exceptional stresses that have been specified during their period in service. The safety repercussions of any accidental failures must be limited by appropriate means.'

As far as the Traffic Operation and Management subsystem is concerned, this essential requirement is addressed by the specification of Subsection 'train visibility' (sub sections 4.2.2.1 and 4.3).

Essential requirement 1.1.4 of Annex III to Directive 96/48/EC:

'The design of fixed installations and rolling stock and the choice of the materials used must be aimed at limiting the generation, propagation and effects of fire and smoke in the event of a fire.'

This essential requirement is not relevant to the Traffic Operation and Management subsystem.

Essential requirement 1.1.5 of Annex III to Directive 96/48/EC:

'Any devices intended to be handled by users must be so designed as not to impair the safe operation of the devices or the health and safety of users if used foreseeably in a manner not in accordance with the posted instructions.'

This essential requirement is not relevant to the Traffic Operation and Management subsystem.

3.3.2. Reliability and availability

Essential requirement 1.2 of Annex III to Directive 96/48/EC:

'The monitoring and maintenance of fixed or movable components that are involved in train movements must be organised, carried out and quantified in such a manner as to maintain their operation under the intended conditions.'

This essential requirement is not relevant to the Traffic Operation and Management subsystem.

3.3.3. Health

Essential requirement 1.3.1 of Annex III to Directive 96/48/EC:

'Materials likely, by virtue of the way they are used, to constitute a health hazard to those having access to them must not be used in trains and railway infrastructure.'

This essential requirement is not relevant to the Traffic Operation and Management subsystem.

Essential requirement 1.3.2 of Annex III to Directive 96/48/EC:

'Those materials must be selected, deployed and used in such a way as to restrict the emission of harmful and dangerous fumes or gases, particularly in the event of fire.'

This essential requirement is not relevant to the Traffic Operation and Management subsystem.

3.3.4. Environmental protection

Essential requirement 1.4.1 of Annex III to Directive 96/48/EC:

'The repercussions on the environment of the establishment and operation of the trans-European high speed rail system must be assessed and taken into account at the design stage of the system in accordance with the Community provisions in force.'

This essential requirement is not relevant to the Traffic Operation and Management subsystem.

Essential requirement 1.4.2 of Annex III to Directive 96/48/EC:

'The materials used in the trains and infrastructures must prevent the emission of fumes or gases which are harmful and dangerous to the environment, particularly in the event of fire.'

This essential requirement is not relevant to the Traffic Operation and Management subsystem.

Essential requirement 1.4.3 of Annex III to Directive 96/48/EC:

'The rolling stock and energy-supply systems must be designed and manufactured in such a way as to be electromagnetically compatible with the installations, equipment and public or private networks with which they might interfere.'

This essential requirement is not relevant to the Traffic Operation and Management subsystem.

3.3.5. Technical compatibility

Essential requirement 1.5 of Annex III to Directive 96/48/EC:

'The technical characteristics of the infrastructure and fixed installations must be compatible with each other and with those of the trains to be used on the trans-European high speed rail system.'

'If compliance with these characteristics proves difficult on certain sections of the network, temporary solutions, which ensure compatibility in the future, may be implemented.'

This essential requirement is not relevant to the Traffic Operation and Management subsystem.

3.4. **Aspects relating specifically to the Traffic Operation and Management subsystem**

3.4.1. Safety

Essential requirement 2.7.1 of Annex III to Directive 96/48/EC:

'Alignment of the network operating rules and the competences of drivers and on-board staff must be such as to ensure safe international operation.'

The operations and maintenance intervals, the training and qualifications of maintenance staff and the quality assurance system set up in the maintenance centres of the operators concerned must be such as to ensure a high level of safety.'

The essential requirement is addressed by the following Subsections of this specification:

- Vehicle identification (Subsection 4.2.2.3)
- Train braking (Subsection 4.2.2.6)
- Train composition (Subsection 4.2.2.5)
- Requirements for passenger vehicles (Subsection 4.2.2.4)
- Ensuring that the train is in running order (Subsection 4.2.2.7)
- Train visibility (Subsections 4.2.2.1 and 4.3)
- Train audibility (Subsections 4.2.2.2 and 4.3)
- Train departure (Subsection 4.2.3.3)
- Traffic management (Subsection 4.2.3.4)
- Signal sighting and vigilance device (Subsection 4.3)
- Safety related communication (Subsections 4.2.1.5 and 4.6)
- Documentation for drivers (Subsection 4.2.1.2)
- Documentation for Railway Undertaking staff other than drivers (Subsection 4.2.1.3)

- Documentation for Infrastructure Manager's staff authorising train movements (Subsection 4.2.1.4)
- Degraded operation (Subsection 4.2.3.6)
- Managing an emergency situation (Subsection 4.2.3.7)
- ERTMS operating rules (Subsection 4.4)
- Professional competences (Subsections 2.2.1 and 4.6)
- Health and safety conditions (Subsections 2.2.1 and 4.7)

3.4.2. Reliability and availability

Essential requirement 2.7.2 of Annex III to Directive 96/48/EC:

'The operation and maintenance periods, the training and qualifications of the maintenance staff and the quality assurance system set up by the operators concerned in the maintenance centres must be such as to ensure a high level of system reliability and availability.'

The essential requirement is ensured by the following Subsections of this specification:

- Train composition (Subsection 4.2.2.5)
- Ensuring that the train is in running order (Subsection 4.2.2.7)
- Traffic Management (Subsection 4.2.3.4)
- Safety Related communication (Subsection 4.2.1.5)
- Degraded operation (Subsection 4.2.3.6)
- Managing an emergency situation (Subsection 4.2.3.7)
- Professional competences (Subsection 4.6)
- Health and safety conditions (Subsection 4.7)

3.4.3. Technical compatibility

Essential requirement 2.7.3 of Annex III to Directive 96/48/EC:

'The alignment of the operating rules of the networks and the qualifications of drivers, on-board staff and managers in charge of traffic must be such as to ensure operating efficiency on the trans-European high speed rail system.'

The essential requirement is addressed by the following Subsections of this specification:

- Vehicle identification (Subsection 4.2.2.3)
- Train Braking (Subsection 4.2.2.6)
- Train composition (Subsection 4.2.2.5)
- Requirements for passenger vehicles (Subsection 4.2.2.4)
- Safety Related communication (Subsection 4.2.1.5)
- Degraded operation (Subsection 4.2.3.6)
- Managing an emergency situation (Subsection 4.2.3.7)

4. CHARACTERISTICS OF THE SUB-SYSTEM

4.1. Introduction

The trans-European high speed rail system (TEN), to which Directive 96/48/EC applies and of which the Traffic Operation and Management subsystem is a part, is an integrated system whose consistency must be verified. This consistency must be checked in particular with regard to the specifications of the subsystem, its interfaces vis-à-vis the system with which it is integrated, as well as the operating rules.

Taking into account all the relevant essential requirements, the Traffic Operation and Management subsystem, as described in Subsection 2.2, covers only the elements specified in the following section.

In conformity with Directive 2001/14/EC, it is the overall responsibility of the Infrastructure Manager to provide all the appropriate requirements which must be met by trains permitted to run on his network, taking into account the geographic particularities of individual lines and the functional or technical specifications set out below.

4.2. Functional and technical specifications of the sub-system

The functional and technical specifications of the Traffic Operation and Management subsystem comprise of the following:

- specifications relating to staff
- specifications relating to trains
- specifications relating to train operations

4.2.1. Specifications relating to staff

4.2.1.1. General requirements

This section deals with the staff who contributes to the operation of the subsystem by performing safety critical tasks involving a direct interface between Railway Undertakings and Infrastructure Managers.

- Railway Undertaking staff:
 - undertaking the task of driving trains and forming part of the 'traincrew' (referred to throughout this document as 'driver')
 - undertaking tasks on-board (other than driving) and forming part of the 'traincrew'
 - undertaking the task of preparing trains
- Infrastructure Manager's staff undertaking the task of authorising the movement of trains

The areas covered are:

- Documentation
- Communication

and, in the scope specified in section 2.2 of this TSI:

- Competences (see Subsection 4.6 and Annexes H, J and L)
- Health and Safety conditions (see Subsection 4.7)

4.2.1.2. Documentation for drivers

The Railway Undertaking operating the train must supply the driver in due time with all the necessary information required to carry out his duties.

This information must take into account the necessary elements for operation in normal, degraded and emergency situations for the routes to be worked over and the rolling stock used on those routes.

4.2.1.2.1. Rule Book

All the necessary procedures for the driver must be included in a document or a computer medium called the 'Driver's Rule Book'.

The 'Driver's Rule Book' must state the requirements for all the routes worked and the rolling stock used on those routes according to the situations of normal operation, degraded operation and in emergency situations which the driver may encounter.

The 'Driver's Rule Book' must cover two distinct aspects:

- one which describes the set of common rules and procedures valid across the TEN (taking into account the contents of Annexes A, B and C)
- another which sets out any necessary rules and procedures specific to each Infrastructure Manager

It must include procedures covering, as a minimum, the following aspects:

- Staff Safety and Security
- Signalling and Control Command
- Train Operation including degraded mode
- Traction and Rolling Stock
- Incidents and accidents

The Railway Undertaking is responsible for compiling this document.

The Railway Undertaking must present the Driver's Rule Book in the same format for the entire infrastructure over which their drivers will work.

It shall have two appendices:

- appendix 1: Manual of communication procedures;
- appendix 2: Book of Forms

The Railway Undertaking must write the driver's rule book in either the language of one of the Member States or the 'operating' language of one of the Infrastructure Managers to which the rules will apply. This will not apply for messages and forms which must remain in the 'operating' language of Infrastructure Manager(s).

The process for preparing and updating the Driver's Rule Book shall include the following steps:

- the Infrastructure Manager (or the organisation responsible for the preparation of the operating rules) must provide the Railway Undertaking with the appropriate information in the Infrastructure Manager's 'operating' language,
- the Railway Undertaking must draw up the initial or updated document;
- if the language chosen by the Railway Undertaking for the Driver's Rule Book is not the language in which the appropriate information was originally supplied, it is the responsibility of the Railway Undertaking to arrange for any necessary translation.

In conformity with Annex III paragraph 2 of Directive 2004/49/EC, the Infrastructure Manager's Safety Management System must contain a validation process to ensure that the content of the documentation provided to the Railway Undertaking(s) is complete and accurate.

In conformity with Annex III paragraph 2 of Directive 2004/49/EC, the Railway Undertaking's Safety Management System must contain a validation process to ensure the content of the Rule Book is complete and accurate.

Annex V outlines this process in flowchart format and provides an overview to the process.

4.2.1.2.2. Description of the line and the relevant lineside equipment associated with the lines worked over

Drivers must be provided with a description of the lines and the associated lineside equipment for the lines over which they will operate and relevant to the driving task. Such information must be set out in a single document called the 'Route Book' (which can either be a traditional document or computer based).

The following is a list of information which must as a minimum, be provided:

- the general operating characteristics
- indication of rising and falling gradients
- detailed line diagram

4.2.1.2.2.1. Preparation of the Route Book

The Route Book must be prepared in either a language of one of the Member States chosen by the Railway Undertaking or the 'operating' language used by the Infrastructure Manager.

The following information must be included (this list is not exhaustive):

- the general operating characteristics:
 - type of signalling and corresponding running regime (double track, reversible working, left or right hand running, etc.)
 - type of power supply
 - type of ground-train radio equipment.
- indication of rising and falling gradients:
 - gradient values and their precise location
- detailed line diagram:
 - names of stations on the line and key locations and their location;
 - tunnels — including, location, name, length, specific information such as the existence of walkways and points of safe egress as well as the location of safe places where evacuation of passengers can take place
 - essential locations such as neutral sections
 - permissible speed limits for each track, including, if necessary, differential speeds relating to certain types of train
 - the name of the organisation responsible for traffic management control and the name(s) of the traffic management control areas;
 - the names and areas of control of traffic management centres such as signal boxes;
 - identification of the radio channels to be used;

The format of the Route Book must be prepared in the same manner for all the infrastructures worked over by the trains of an individual Railway Undertaking.

The Railway Undertaking is responsible for the preparation of the Route Book using the information supplied by the Infrastructure Manager(s).

In conformity with Annex III paragraph 2 of Directive 2004/49/EC, the Infrastructure Manager's Safety Management System must contain a validation process to ensure that the content of the documentation provided to the Railway Undertaking(s) is complete and accurate.

In conformity with Annex III paragraph 2 of Directive 2004/49/EC, the Railway Undertaking's Safety Management System must contain a validation process to ensure the content of the Route Book is complete and accurate.

4.2.1.2.2.2. Modified elements

The Infrastructure Manager must advise any elements modified either permanently or temporarily to the Railway Undertaking. Changes must be made known in time for the RU to process their impact, update documents and instruct staff. They must be grouped by the Railway Undertaking into a dedicated document or computer medium whose format must be the same for all the infrastructures worked over by the trains of an individual Railway Undertaking.

In conformity with Annex III paragraph 2 of Directive 2004/49/EC, the Infrastructure Manager's Safety Management System must contain a validation process to ensure that the content of the documentation provided to the Railway Undertaking(s) is complete and accurate.

In conformity with Annex III paragraph 2 of Directive 2004/49/EC, the Railway Undertaking's Safety Management System must contain a validation process to ensure the content of the document of modified elements is complete and accurate.

4.2.1.2.2.3. Informing the driver in real time

The procedure for advising drivers in real time about all modifications to safety arrangements on the route must be defined by the Infrastructure Managers concerned (the process must be unique where ERTMS/ETCS is in use).

4.2.1.2.3. Timetables

The provision of train schedule information facilitates the punctual running of trains and assists in service performance.

The Railway Undertaking must provide drivers with the information necessary for the normal running of the train and as a minimum include:

- the train identification;
- the train running days (if necessary);
- the stopping points and the activities associated with them
- other timing points;
- the arrival/departure/passing times at each of those points.

Such train running information, which must be based on information supplied by the Infrastructure Manager, may be provided either electronically or in a paper format.

Presentation to the driver must be consistent across all the lines over which the Railway Undertaking operates.

4.2.1.2.4. Rolling stock

The Railway Undertaking must provide the driver with all information relevant to the working of the rolling stock during degraded situations (such as trains requiring assistance). Such documentation must also focus on the specific interface with the Infrastructure Manager's staff in these cases.

4.2.1.3. Documentation for Railway Undertaking staff other than drivers

The Railway Undertaking must provide all members of his staff (whether on train or otherwise) who undertake safety critical tasks involving a direct interface with the staff, equipment or systems of the Infrastructure Manager with the rules, procedures, rolling stock and route specific information it deems appropriate to such tasks. Such information shall be applicable in both normal and degraded operation.

For staff on-board trains, the structure, format, content and process for preparation and updating of such information must be based on the specification set out in Subsection 4.2.1.2 of this TSI.

4.2.1.4. Documentation for Infrastructure Manager's staff authorising train movements

All the information necessary to ensure safety-related communication between staff authorising the movement of trains and train crews must be set out in:

- documents describing the Communications Protocol (annex C);
- the document entitled Book of Forms.

The Infrastructure Manager must draw up these documents in his 'operating' language.

4.2.1.5. Safety-related communications between traincrew, other Railway Undertaking staff and staff authorising train movements

The language used for safety-related communication between traincrew, other Railway Undertaking staff (as defined in Annex L) and the staff authorising train movements shall be the 'operating' language (see glossary) used by the Infrastructure Manager on the route concerned.

The principles for safety-related communication between traincrew and staff responsible for authorising the movement of trains are to be found in Annex C.

In conformity with Directive 2001/14/EC, the Infrastructure Manager is responsible for publishing the 'operating language' used by his personnel in daily operational use.

Where however, local practice requires that a second language is also provided for, it is the responsibility of the Infrastructure Manager to determine the geographic boundaries for its use.

4.2.2. Specifications relating to trains

4.2.2.1. Train visibility

4.2.2.1.1. General requirement

The Railway Undertaking must ensure that trains are fitted with means of indicating the front and rear of the train.

4.2.2.1.2. Front end

The Railway Undertaking must ensure that an approaching train is clearly visible and recognisable as such, by the presence and layout of its lit white front-end lights. This is to enable it to be distinguished as an approaching train from nearby road vehicles or other moving objects.

The detailed specification can be found in Subsection 4.3.3.4.1.

4.2.2.2. Train audibility

4.2.2.2.1. General requirement

The Railway Undertaking must ensure that trains are fitted with an audible warning device to indicate the approach of a train.

4.2.2.2.2. Control

The ability to sound the audible warning device must be possible from all driving positions.

4.2.2.3. Vehicle identification

Each vehicle must have a number to uniquely identify it from any other rail vehicle. This number must be prominently displayed at least on each longitudinal side of the vehicle.

It must also be possible to identify operational restrictions applicable to the vehicle.

Further requirements are specified in Annex P.

4.2.2.4. Requirements for Passenger vehicles

- Compatibility between passenger vehicles and platforms at scheduled passenger stops must be sufficient in order to ensure safe access and egress.
- Passengers must not be able to open body-side doors intended for their use until the train is at a standstill and the doors have been released by a member of the train crew.
- Door release must be separate for each side of the train. The integrity of door closure and blocking on passenger trains must be permanently indicated.
- Activation of the door release must prevent traction power from being applied. (For the purposes of this requirement, 'door release' means the doors have been enabled by the traincrew for opening by passengers.)
- All vehicles carrying passengers must be equipped with exits that facilitate emergency egress.
- Vehicles intended for passenger use must have either a passenger activated alarm or emergency brake fitted. In the event of this being triggered, the driver must be immediately alerted but be able to retain control of the train.

4.2.2.5. Train composition

The Railway Undertaking must define the rules and procedures to be followed by his staff so as to ensure that the train is in compliance with the allocated path.

Train Composition requirements must take into account the following elements:

- the vehicles
 - all vehicles in the train must be in compliance with all the requirements applicable on the routes over which the train will run;
 - all vehicles on the train must be fit to run at the maximum speed at which the train is scheduled to run;
 - all vehicles on the train must be currently within their specified maintenance interval and will remain so for the duration (in terms of both time and distance) of the journey being undertaken;
- the train
 - the combination of vehicles forming a train must comply with the technical constraints of the route concerned and be within the maximum length permissible for forwarding and receiving terminals;
 - the Railway Undertaking is responsible for ensuring that the train is technically fit for the journey to be undertaken and remains so throughout the journey;

- the weight and axle load
 - the weight of the train must be within the maximum permissible for the section of route, the strength of the couplings, the traction power and other relevant characteristics of the train. Axle load limitations must be respected;
- the maximum speed of the train
 - the maximum speed at which the train can run must take into account any restrictions on the route(s) concerned, braking performance, axle load and vehicle type;
- the kinematic envelope
 - the kinematic gauge of each vehicle (inclusive of any load) in the train must be within the maximum permissible for the section of route.

Additional constraints may be required or imposed due to the type of braking regime or traction type on a particular train.

Train composition must be described in a harmonised train composition document (see Annex U)

4.2.2.6. Train braking

4.2.2.6.1. Minimum requirements of the braking system

All vehicles in a train must be connected to the continuous automatic braking system as defined in the RST TSI.

The first and last vehicles (including any traction units) in any train must have the automatic brake operative.

In the case of a train becoming accidentally divided into two parts, both sets of detached vehicles must come automatically to a stand as a result of a maximum application of the brake.

4.2.2.6.2. Brake performance

The Infrastructure Manager must decide whether to:

- provide Railway Undertakings with the information necessary for calculating the required braking performance for the route(s) concerned, including information on the braking systems which can be accepted, and on the conditions of their use, or
- alternatively provide the actual performance required.

The Railway Undertaking is responsible for ensuring that the train has sufficient braking performance by providing braking rules for its staff to follow.

The information required by the Railway Undertaking to calculate the braking performance enabling their trains to stop and remain stopped must take into account the geography of all the routes involved, the allocated pathway and the development of ERTMS/ETCS.

Further requirements are specified in Annex T.

4.2.2.7. Ensuring that the train is in running order

4.2.2.7.1. General requirement

The Railway Undertaking must define the process to ensure that all safety-related on-train equipment is in a fully functional state and that the train is safe to run.

The Railway Undertaking must inform the Infrastructure Manager of any modification to the characteristics of the train affecting its performance or any modification that might affect the ability to accommodate the train in its allocated path.

The Infrastructure Manager and the Railway Undertaking must define and keep up to date conditions and procedures for train running in degraded mode.

4.2.2.7.2. Data required

The data required for safe and efficient operation and the process by which this data must be forwarded must comprise:

- the train identification
- the identity of the Railway Undertaking responsible for the train
- the actual length of the train
- if a train carries passengers or animals when it is not scheduled to do so
- any operational restrictions with an indication of the vehicle(s) concerned (gauge, speed restrictions, etc.)
- information the Infrastructure Manager requires for transport of dangerous goods.

The Railway Undertaking must define a process in order to ensure that this data is made available to the Infrastructure Manager(s) prior to the departure of the train.

The Railway Undertaking must define a process for advising the Infrastructure Manager(s) if a train will not occupy its allocated path or is cancelled.

4.2.3. Specifications relating to train operations

4.2.3.1. Train planning

The Infrastructure Manager must advise what data is required when a train path is requested. Further aspects of this element are set out in Directive 2001/14/EC.

4.2.3.2. Identification of trains

An unambiguous identification for all trains must exist.

These requirements are specified in Annex R.

4.2.3.3. Train departure

4.2.3.3.1. Checks and tests before departure

The Railway Undertaking must, in accordance with the requirements set out in the third paragraph of clause 4.1 of this TSI and all applicable rules, define the checks and tests (especially in relation to brakes) that must be undertaken before departure.

4.2.3.3.2. Informing the Infrastructure Manager of the train's operational status

The Railway Undertaking must inform the Infrastructure Manager of any anomaly affecting the train or its operation having possible repercussions on the train's running prior to departure and during the journey.

4.2.3.4. Traffic management

4.2.3.4.1. General requirements

Traffic management must ensure the safe, efficient and punctual operation of the railway, including effective recovery from service disruption.

The Infrastructure Manager must determine procedures and means for:

- the real time management of trains,
- operational measures to maintain the highest possible performance of the infrastructure in case of delays or incidents, whether actual or anticipated, and
- the provision of information to Railway Undertakings in such cases.

Any additional processes required by the Railway Undertaking and which affect the interface with the Infrastructure Manager(s) can be introduced after being agreed with the Infrastructure Manager.

4.2.3.4.2. Train reporting

4.2.3.4.2.1. Data required for train position reporting

The Infrastructure Manager must:

- provide a means of real time recording of the times at which trains depart from, arrive at or pass appropriate pre-defined reporting points on their networks and the delta-time value;
- provide the specific data required in relation to train position reporting. Such information must include:
 - Train identification
 - Identity of reporting point
 - Line on which the train is running
 - Scheduled time at reporting point
 - Actual time at reporting point (and whether depart, arrive or pass — separate arrival and departure times must be provided in respect of intermediate reporting points at which the train calls)
 - Number of minutes early or late at the reporting point
 - Initial explanation of any single delay exceeding 10 minutes or as otherwise required by the performance monitoring regime
 - Indication that a report for a train is overdue and the number of minutes by which it is overdue
 - Former train identification(s), if any
 - Train cancelled for a whole or a part of its journey.

4.2.3.4.2.2. Predicted hand over time

The Infrastructure Manager must have a process, which enables an indication of the estimated number of minutes of deviation from the scheduled time a train is scheduled to be handed over from one Infrastructure Manager to another.

This must include information on service disruption (description and location of problem).

4.2.3.4.3. Dangerous goods

The Railway Undertaking must define the procedures to supervise the transport of dangerous goods.

These procedures must include:

- existing European standards as specified in EC directive 96/49 for identifying dangerous goods on board a train
- advice to the driver of the presence and position of dangerous goods on the train
- information the Infrastructure Manager requires for transport of dangerous goods
- **determination of, in conjunction with the Infrastructure Manager, lines of communication and planning of specific measures in case of emergency situations involving the goods.**

4.2.3.4.4. Operational quality

Infrastructure Managers and Railway Undertakings shall have processes in place to monitor the efficient operation of the all the services concerned.

Monitoring processes shall be designed to analyse data and detect underlying trends, both in terms of human error and system error. The results of this analysis shall be used to generate improvement actions, designed to eliminate or mitigate against events which could compromise the efficient operation of the trans-European high speed rail system.

Where such improvement actions would have network-wide benefits, involving other Infrastructure Managers and Railway Undertakings, then, subject to commercial confidentiality, they shall be communicated accordingly.

Events that have significantly disrupted operations shall be analysed as soon as possible by the Infrastructure Manager. Where appropriate, and in particular where one of their staff is concerned, the Infrastructure Manager shall invite those Railway Undertakings involved in the event concerned to participate in the analysis. Where the result of such analysis leads to network improvement recommendations designed to eliminate or mitigate against causes of accidents/incidents, these shall be communicated to all relevant Infrastructure Managers and Railway Undertakings concerned.

These processes shall be documented and subject to internal audit.

4.2.3.5. Data recording

Data pertaining to the running of a train must be recorded and retained for the purposes of:

- Supporting systematic safety monitoring as a means of preventing incidents and accidents.
- Identifying driver, train and infrastructure performance in the period leading up to and (if appropriate) immediately after an incident or accident, to enable the identification of causes related to train driving or train equipment, and supporting the case for new or changed measures to prevent recurrence.
- Recording information relating to the performance and where appropriate, the working time of both the locomotive/traction unit and the person driving.

It must be possible to match recorded data to:

- the date and time of the recording
- the precise geographic location of the event being recorded (distance in kilometres from a recognisable location)
- the train identification
- the identity of the driver

Requirements with regard to storage, periodic evaluation of and access to this data are specified in relevant national laws of the Member State:

- in which the Railway Undertaking is licensed (with regard to on-board recorded data), or
- of the Member State in which the infrastructure is located (with regard to data recorded outside the train).

4.2.3.5.1. Recording of supervision data outside the train

As a minimum, the Infrastructure Manager must record the following data:

- the failure of lineside equipment associated with the movement of trains (signalling, points etc.);
- the detection of an overheating axle bearing;
- communication between the train driver and Infrastructure Manager's staff authorising train movements.

4.2.3.5.2. Recording of supervision data on-board the train

As a minimum, the Railway Undertaking must record the following data:

- the passing of signals at danger or 'end of movement authority' without authority
- application of the emergency brake
- speed at which the train is running
- any isolation or overriding of the on-board train control (signalling) systems
- operation of the audible warning device (horn)
- operation of door controls (release, closure)
- detection by on-board hot axle box detectors, if fitted
- identity of the cab for which data is being recorded to be checked
- data in order to record working time of drivers.

4.2.3.6. Degraded operation

4.2.3.6.1. Advice to other users

Infrastructure Managers in conjunction with Railway Undertakings must define a process to immediately inform each other of any situation that impedes the safety, performance and/or the availability of the rail network or rolling stock.

4.2.3.6.2. Advice to train drivers

In any case of degraded operation associated with the Infrastructure Manager's area of responsibility, the Infrastructure Manager must give formal instructions to drivers on what measures to take in order to safely overcome the degradation.

4.2.3.6.3. Contingency arrangements

The Infrastructure Manager in conjunction with all the Railway Undertakings operating over his infrastructure, and neighbouring Infrastructure Managers as appropriate, must define, publish and make available appropriate contingency measures and assign responsibilities based on the requirement to reduce any negative impact as a result of degraded operation.

The planning requirements and the response to such events must be proportional to the nature and potential severity of the degradation.

These measures, which must as a minimum include plans for recovering the network to 'normal' status, may also address:

- rolling stock failures (for example, those which could result in substantial traffic disruption, the procedures for rescuing failed trains);
- infrastructure failures (for example, when there has been a failure of the electric power or the conditions under which trains may be diverted from the booked route);
- extreme weather conditions.

The Infrastructure Manager must establish and keep updated contact information for key Infrastructure Manager and Railway Undertaking staff who may be contacted in the event of service disruption leading to degraded operation. This information must include contact details both during and outside office hours.

The Railway Undertaking must submit this information to the Infrastructure Manager and advise the Infrastructure Manager of any changes to these contact details.

The Infrastructure Manager must advise all the Railway Undertakings of any changes to his details.

4.2.3.7. Managing an emergency situation

The Infrastructure Manager shall, in consultation with:

- all Railway Undertakings operating over his infrastructure, or
- where appropriate, representative bodies of railway undertakings operating over his infrastructure, and
- neighbouring Infrastructure Managers, as appropriate, as well as
- local authorities and
- representative bodies at either local or national level as appropriate, of the emergency services including fire fighting and rescue

and in conformity with Directive 2004/49/EC, define, publish and make available appropriate measures to manage emergency situations and restore the line to normal operation.

Such measures shall typically cover:

- collisions,
- fires on train,
- evacuation of trains,
- accidents in tunnels,
- incidents involving dangerous goods,
- derailments.

The Railway Undertaking shall provide the Infrastructure Manager with any specific information in respect to these circumstances, especially in respect to the recovery or re-railing of their trains. (See also clause 4.2.7.5 in the Conventional Rail Freight Wagon TSI).

Additionally, the Railway Undertaking shall have processes to inform passengers about onboard emergency and safety procedures.

4.2.3.8. Aid to traincrew in the event of an incident or of a major rolling stock malfunction

The Railway Undertaking shall define appropriate procedures to assist the train crew in degraded situations in order to avoid or decrease delays caused by technical or other failures of the rolling stock (e.g. lines of communication, measures to be taken in case of evacuation of a train).

4.3. **Functional and technical specifications of the interfaces**

In light of the essential requirements in Chapter 3, the functional and technical specifications of the interfaces are as follows:

4.3.1. Interfaces with the Infrastructure TSI

4.3.1.1. Signal Sighting

The driver must be able to observe signals, and signals must be observable by the driver from his normal driving position. The same applies for line side signs if they are safety related.

Lineside signs and information boards must be designed in such a consistent way to facilitate this. Issues that must be taken into account include:

- suitably sited so that train headlights allow the driver to read the information
- suitability and intensity of lighting, where required to illuminate the information
- where retro-reflectivity is employed, the reflective properties of the material used are in compliance with appropriate specifications and that they are fabricated so as to allow train headlights to allow the driver to read the information

4.3.1.2. Passenger Vehicles

The compatibility between passenger vehicles and platforms of scheduled passenger stops in order to ensure safe access and egress must be assured.

The minimum distance between platform surfaces and live electrical parts of vehicles must be respected.

4.3.1.3. Professional Competences

There is an interface with subsection 2.2.1 of this TSI and subsection 4.6 of the HS INS TSI.

4.3.2. Interfaces with the Control/Command and Signalling TSI

4.3.2.1. Recording of supervision data

The Traffic Operation and Management subsystem determines the operational requirements for the recording of supervision data (see Subsection 4.2.3.5 of this TSI) with which the Control/Command subsystem (see section 4.2.15 of the HS CCS TSI) must comply.

4.3.2.2. Driver vigilance

Where the infrastructure supports the facility, this device shall be capable of automatically reporting an activation to the controlling signalling centre. There is an interface between this operational requirement and Subsection 4.2.2 in the HS CCS TSI associated with ERTMS.

4.3.2.3. ERTMS/ETCS and ERTMS/GSM-R operating rules

Annex A of this TSI has an interface with the ERTMS/ETCS FRS and SRS, the ERTMS/GSM-R FRS and SRS detailed in annex A of the HS CCS TSI.

There is also an interface between Subsection 4.4 of this TSI and Annex A of the HS CCS TSI in respect to the informative guideline documents for the rules, principles and implementation of ERTMS.

There is also an interface with the ETCS Driver/Machine Interface (DMI) specifications (section 4.2.13 of the HS CCS TSI) and the EIRENE DMI specifications (section 4.2.14 of the HS CCS TSI).

There is an interface between annex A of this TSI and subsection 4.2.2 of the HS CCS TSI in respect to isolation of the On-Board ETCS functionality.

4.3.2.4. Signal and lineside marker sighting

The driver must be able to observe signals and lineside markers, and they must be observable by the driver from his normal driving position. The same applies for other types of lineside signs if they are safety related.

Lineside markers, signs and information boards shall be designed in such a consistent way to facilitate this. Issues that must be taken into account include:

- that they are suitably sited so that train headlights allow the driver to read the information,
- suitability and intensity of lighting, where required to illuminate the information,
- where retro-reflectivity is employed, the reflective properties of the material used are in compliance with appropriate specifications and the signs are fabricated so that train headlights easily allow the driver to read the information.

There is an interface with subsection 4.2.16 of the HS CCS TSI in respect to driver's external field of view. There will also be a new item in a future version of Annex A of the HS CCS TSI in respect to lineside markers on ETCS-fitted lines.

4.3.2.5. Train braking

An interface exists between subsection 4.2.2.6.2 of this TSI and subsection 4.3.1.5 (Guaranteed train braking performance and characteristics) of the HS CCS TSI.

4.3.2.6. Use of sanding. Minimum elements relevant to professional competences for the task of driving a train

An interface exists between annex H and annex B (§ C1) of this TSI on one hand, and subsection 4.2.11 (compatibility with track-side Train Detection Systems) and § 4.1 of appendix 1 of Annex A (as quoted in subsection 4.3.1.10) of the HS CCS TSI on the other hand, in respect to the use of sanding.

4.3.2.7. Data recording and hot axle box detection

An interface exists between subsection 4.2.3.5 of this TSI on one hand, and subsection 4.2.2 (On-board ETCS functionality), indexes 5, 7 and 55 in annex A, and subsection 4.2.10 (HABD (Hot Axle Box Detector)) of the HS CCS TSI on the other hand. There will be a future interface with annex B of the OPE TSI, when the HS CCS open point is resolved.

4.3.3. Interfaces with the Rolling Stock TSI

4.3.3.1. Braking

Interfaces exists between Subsection 4.2.2.5.1, 4.2.2.6.1 and 4.2.2.6.2 of this OPE TSI, and subsection 4.2.4.1 and 4.2.4.3 of the HS RST TSI.

An interface also exists between subsection 4.2.4.5 (Eddy Current brakes) of the HS RST TSI and subsection 4.2.2.6.2 of this OPE TSI.

An interface also exists between subsection 4.2.4.6 (protection of an immobilised train) of the HS RST TSI and subsection 4.2.2.6.2 of this OPE TSI.

An interface also exists between subsection 4.2.4.7 (brake performance on steep gradients) of the HS RST TSI and subsections 4.2.2.6.2 and 4.2.1.2.2.3 of this OPE TSI.

4.3.3.2. Requirements for passenger vehicles

Interfaces exists between Subsection 4.2.2.4 of this OPE TSI and subsections 4.2.2.4 (doors), 4.2.5.3 (alarms), 4.3.5.16 (passenger alarm) and 4.2.7.1 (emergency exits) of the HS RST TSI.

4.3.3.3. Train visibility

The Traffic Operation and Management subsystem determines that the basic requirements for train visibility, which the Rolling Stock subsystem must define, are shown in the following clauses.

4.3.3.3.1. On the leading vehicle of a train facing in the direction of travel

The forward facing front-end of the leading vehicle of a train must be fitted with three lights, in the shape of an isosceles triangle, as shown below. These lights shall always be lit when the train is being driven from that end.

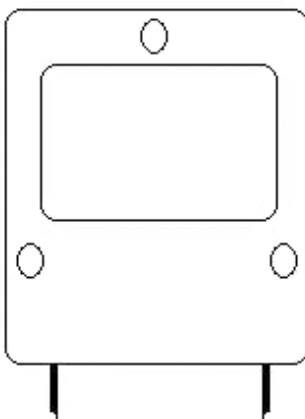

The front lights must optimise train detectability (e.g. to track workers and those using public crossings), provide sufficient visibility for the train driver (illumination of the line ahead, lineside information markers/boards, etc) by night and during low light conditions and shall not dazzle the drivers of oncoming trains.

The spacing, the height above rails, the diameter, the intensity of the lights, the dimensions and shape of the emitted beam in both day and night time operation must be standardised.

An interface exists with subsection 4.2.7.4.1 of the HS RST TSI and Subsection 4.2.2.1.2 of this TSI.

4.3.3.3.2. On the rear end

An interface exists between subsection 4.2.2.1.3 of this TSI and subsection 4.2.7.4.1 of the HS RST TSI.

4.3.3.4. Train audibility

The Traffic Operation and Management subsystem determines that the basic requirements for train audibility with which the Rolling Stock subsystem must comply is that a train must be able to provide an audible warning of its presence.

The sounds emitted by this warning device, the frequency and intensity of these sounds and the method of activation by the driver shall be standardised.

An interface with subsection 4.2.7.4.2 of the HS RST TSI and Subsection 4.2.2.2 of this TSI.

4.3.3.5. Signal sighting

The driver must be able to observe signals, and signals must be observable by the driver. The same applies for line side signs if they are safety related.

Driving cabs shall be designed in such a consistent way that the driver is able to easily see the information displayed to him from his usual driving position.

An interface exists between subsection 4.3.2.4 of this TSI and subsection 4.2.2.7 of the HS RST TSI.

4.3.3.6. Driver vigilance

A means of monitoring the reactions of the driver, intervening to bring the train to a stand if the driver does not react within a time to be specified.

An interface exists between subsections 4.3.3.2 and 4.3.3.7 of this TSI and subsection 4.2.7.9 of the HS RST TSI in respect to driver vigilance.

4.3.3.7. Train composition and annex B

There is an interface between:

- subsections 4.2.2.5, 4.2.3.6.3 and 4.2.3.7 of this TSI on one hand,
- and subsections 4.2.2.2.b (End couplers and coupling arrangements to rescue trains) of the HS RST TSI and its annex K, also subsection 4.2.3.5 (maximum train length) on the other hand,

in respect of:

- the maximum permissible weight of the train on the maximum gradient of the line concerned
- the maximum train length, and
- acceleration in case of banking.

4.3.3.8. Rolling Stock parameters which influence ground-based train monitoring systems and rolling stock dynamic behaviour

Interfaces exists between subsections 4.2.3.3.2 and 4.2.3.4 of the HS RST TSI and subsection 4.2.3.6 of this OPE TSI.

- 4.3.3.9. Sanding
- An interface exists between annex H and annex B (§ C1) of this TSI on one hand, and subsection 4.2.3.10 the HS RST TSI on the other hand, in respect to the use of sanding.
- 4.3.3.10. Train composition, annexes H and J
- Interfaces exist between subsection 4.2.2.5 and Annexes H and J of this TSI with subsections 4.2.1.2 (design of train) and 4.2.7.11 (Monitoring and diagnostic concepts) of the HS RST TSI in respect to train crew knowledge of rolling stock functionality.
- 4.3.3.11. Contingency arrangements and Managing an emergency situation
- There is an interface between subsection 4.2.3.6.3 and 4.2.3.7 of this TSI and subsection 4.2.2.2 (end couplers and coupling arrangements to rescue trains) and Annex K of the HS RST TSI.
- There is also an interface between subsections 4.2.3.6 and 4.2.3.7 of this TSI and subsection 4.2.7.1 (Emergency measures) and 4.2.7.2 (Fire safety) of the HS RST TSI.
- 4.3.3.12. Data recording
- There is an interface between subsection 4.2.3.5.2 (Recording of supervision data on-board the train) of this TSI and subsection 4.2.7.11 of the HS RST TSI (Monitoring and diagnostic concepts).
- 4.3.3.13. Aerodynamic effects on ballast
- An interface exists between subsection 4.2.3.11 of the HS RST TSI and subsection 4.2.1.2.2.3 of this TSI.
- 4.3.3.14. Environmental conditions
- An interface exists between subsection 4.2.6.1 of the HS RST TSI and subsections 4.2.2.5 and 4.2.3.3.2 of this TSI.
- 4.3.3.15. Crosswinds
- An interface exists between subsection 4.2.6.3 of the HS RST TSI and subsections 4.2.1.2.2.3 and 4.2.3.6 of this TSI.
- 4.3.3.16. Maximum pressure variations in tunnels
- An interface exists between subsection 4.2.6.4 of the HS RST TSI and subsections 4.2.1.2.2.3 and 4.2.3.6 of this TSI.
- 4.3.3.17. Exterior noise
- An interface exists between subsection 4.2.6.5 of the HS RST TSI and subsection 4.2.3.7 of this TSI.
- 4.3.3.18. Fire safety
- An interface exists between subsection 4.2.7.2 of the HS RST TSI and subsection 4.2.3.7 of this TSI.
- 4.3.3.19. Lifting/rescue procedures
- An interface exists between subsection 4.2.7.5 of the HS RST TSI and subsection 4.2.3.7 of this TSI.
- 4.3.3.20. Monitoring and diagnostic concepts
- An interface exists between subsection 4.2.7.11 of the HS RST TSI and subsection 4.2.3.5.2 and Annexes H and J of this TSI.
- 4.3.3.21. Particular specification for long tunnels
- An interface exists between subsection 4.2.7.12 of the HS RST TSI and subsections 4.2.1.2.2.1, 4.2.3.7 and 4.6.3.2.3.3 of this TSI.

4.3.3.22. Traction performance requirements

An interface exists between subsection 4.2.8.1 of the HS RST TSI and subsections 4.2.2.5 and 4.2.3.3.2 of this TSI.

4.3.3.23. Traction adhesion requirements

An interface exists between subsection 4.2.8.2 of the HS RST TSI and subsections 4.2.3.3.2, 4.2.3.6 and 4.2.1.2.2 of this TSI.

4.3.3.24. Functional and technical specification related to power supply

An interface exists between subsection 4.2.8.3 of the HS RST TSI and subsections 4.2.3.6 and 4.2.1.2.2 of this TSI.

4.3.4. Interfaces with the HS Energy TSI

There is an interface with subsection 2.2.1 of this TSI and subsection 4.6 of the HS ENE TSI.

4.3.5. Interfaces with the Safety in Rail Tunnels TSI

A number of requirements in the SRT TSI rely on elements within the OPE TSI as a complement. These are detailed in subsection 4.3.4 of the SRT TSI.

A specific interface exists between subsection 4.2.5.1.3.2 of the SRT TSI and subsection 4.6.3.2.3.3 of this TSI.

4.3.6. Interfaces with the Persons with Reduced Mobility TSI

A number of requirements in the PRM TSI rely on elements within the OPE TSI. These are detailed in subsections 4.1.4 and 4.2.4 of the PRM TSI.

4.4. **Operating rules**

The rules and procedures enabling coherent operation of new and different structural subsystems intended to be used in the TEN, and in particular those that are linked directly to the operation of a new train control and signalling system, shall be identical where identical situations exist.

To this end, operating rules for the European Train Control System (ETCS) and the Global System for Mobile communication — Railways (GSM-R) have been written. These are specified in Annex A.

AnnexA (ETCS and GSM-R rules and principles) is complemented by the two following informative documents:

- Presentation Report of ETCS/GSM-R Rules and Principles (EEIG Ref.: 05E374)
- Recommendations for the Implementation of ERTMS (EEIG Ref.: 05E375)

Other operating rules, which are able to be standardised across the TEN, are specified in Annex B.

As these rules are designed to be applied across the entire TEN, it is important that there is complete consistency. The only organisation able to make modifications to these rules shall be the ERA, which is responsible for the timely upkeep of Annexes A, B and C to this TSI.

4.5. **Maintenance rules**

Not applicable

4.6. Professional competences

In accordance with Subsection 2.2.1 of this TSI, this section deals with professional and linguistic competence and the assessment process required for staff to attain this competence.

4.6.1. Professional competence

Staff (including contractors) of Railway Undertakings and Infrastructure Managers must have attained appropriate professional competence to undertake all necessary safety-related duties in normal, degraded and emergency situations. Such competence comprises professional knowledge and the ability to put this knowledge into practice.

Minimum elements relevant to professional competence for individual tasks can be found in annexes H, J and L.

4.6.1.1. Professional knowledge

Taking these annexes into account and dependant on the duties of the individual staff member concerned, the knowledge required will comprise the following:

- general railway operation with particular emphasis on safety-critical activity:
 - principles of operation of their organisation's safety management system;
 - the roles and responsibilities of the key players involved in interoperable operations;
 - appreciation of hazards, especially in relation to the risks involving railway operation and electric traction supply
- appropriate knowledge of safety-related tasks in respect to procedures and interfaces for:
 - lines and lineside equipment;
 - rolling stock;
 - the environment.

4.6.1.2. Ability to put this knowledge into practice

The ability to apply this knowledge in routine, degraded and emergency situations will require staff to be fully acquainted with:

- the method and principles for applying these rules and procedures
- the process for the use of lineside equipment and rolling stock, as well as any specific safety-related equipment
- the principles of the safety management system to avoid the introduction of any undue risk to people and process

as well as a general ability to adapt to the different circumstances an individual may encounter.

In conformity with Annex III clause 2 of Directive 2004/49/EC, Railway Undertakings and Infrastructure Managers are required to establish a competence management system to ensure that the individual competence of their staff involved is assessed and maintained. Additionally, training shall be provided, as necessary, to ensure that knowledge and skills are kept current, especially in relation to weaknesses or deficiencies in system or individual performance.

4.6.2. Linguistic competence

4.6.2.1. Principles

Infrastructure Managers and Railway Undertakings are required to ensure that their relevant personnel are competent in the use of the communication protocols and principles set out in this TSI.

Where the 'operating' language used by the Infrastructure Manager differs from that habitually used by the Railway Undertaking's personnel, such linguistic and communications training must form a critical part of the Railway Undertaking's overall competence management system.

Railway Undertaking staff whose duties require them to communicate with staff of the Infrastructure Manager in connection with safety critical matters, whether in routine, degraded or emergency situations, shall have a sufficient level of knowledge in the 'operating' language of the Infrastructure Manager.

4.6.2.2. Level of knowledge

The level of knowledge in the Infrastructure Manager's language must be sufficient for safety purposes:

- As a minimum this must comprise of the driver being able to:
 - send and understand all the messages specified in annex C to the present TSI;
 - effectively communicate in routine, degraded and emergency situations;
 - complete the forms associated with the use of the 'Book of Forms'.
- Other members of the train crew whose duties require them to communicate with the Infrastructure Manager on safety critical matters, must as a minimum, be able to send and understand information describing the train and its operational status.

Guidance on the appropriate levels of competence is defined in Annex E. The level of knowledge for drivers shall be at least level 3. The level of knowledge for staff accompanying trains shall be at least level 2.

4.6.3. Initial and ongoing assessment of staff

4.6.3.1. Basic elements

In conformity with Annex III clause 2 of Directive 2004/49/EC, Railway Undertakings and Infrastructure Managers are required to define the assessment process for their staff. It is recommended that account be taken of each of the following:

A. Selection of personnel

- evaluation of individual experience and competence
- evaluation of individual competence in the use of any required foreign language(s) or the aptitude to learn them

B. Initial professional training

- analysis of training needs;
- training resources
- training of the trainers

C. Initial assessment

- basic conditions (minimum age for drivers, ...);
- assessment programme, including practical demonstration;
- trainer competence;
- deliver a certificate of competence.

D. Competence retention

- principles for retention of competence
 - in particular, for those staff undertaking the task of driving a train, re-assessment of competence shall be undertaken at least on an annual basis

- methods to be followed
- formalisation of the competence retention process.
- assessment process.

E. Refresher training

- principles for ongoing training (including language)

4.6.3.2. Analysis of training needs

4.6.3.2.1. Development of the analysis of training needs

Railway Undertakings and Infrastructure Managers must undertake an analysis of training needs for their relevant staff.

This analysis must set out both scope and complexity and take into account the risks associated with the operation of trains on the TEN, especially in relation to human capabilities and limitations (human factors) which may come about as a result of:

- differences in operating practices between Infrastructure Managers and the risks associated with changing between these;
- the differences between tasks, operating procedures and communication protocols;
- any difference in the 'operating' language used by the Infrastructure Manager's personnel;
- local operating instructions which may include special procedures or particular equipment to be applied in certain cases, for example a specific tunnel.

Guidance on the elements that should be considered can be found in the annexes referred to in Subsection 4.6.1 above. As appropriate, elements of the training for staff must be put in place which take these into account.

It is possible that due to the type of operation envisaged by a Railway Undertaking or the nature of the network being run by an Infrastructure Manager, some of the elements in these annexes will not be appropriate. The analysis of training needs shall document those not deemed appropriate and the reasons why.

4.6.3.2.2. Updating the analysis of training needs

Railway Undertakings and Infrastructure Managers shall define a process for reviewing and updating their individual training needs, taking into account issues such as previous audits, system feedback and known changes to rules and procedures, infrastructure and technology.

4.6.3.2.3. Specific elements for traincrew and auxiliary staff

4.6.3.2.3.1. Route knowledge

The Railway Undertaking shall define the process by which knowledge of train crew of the routes worked over is acquired and maintained, at the level that is deemed appropriate depending on the level of responsibilities. This process must be:

- based upon the route information provided by the Infrastructure Manager and
- in accordance with the process described in Subsection 4.2.1 of this TSI.

Drivers must learn these routes through both theoretical and practical elements.

4.6.3.2.3.2. Knowledge of rolling stock

The Railway Undertaking shall define the process for the acquisition and retention of traction and rolling stock knowledge by its train crew.

4.6.3.2.3.3. Auxiliary Staff

The RU shall make sure that the auxiliary staff (e.g catering, cleaning) not forming part of the 'traincrew' is, in addition to their basic training, trained to respond to the instructions of the fully trained members of the 'traincrew'.

4.7. Health and Safety Conditions

4.7.1. Introduction

Staff specified in Subsection 4.2.1 as staff performing safety critical tasks in accordance with Subsection 2.2 of this TSI must have appropriate fitness to ensure that overall operational and safety standards are met.

In conformity with Directive 2004/49/EC, Railway Undertakings and Infrastructure Managers shall set up and document the process they put in place to meet the medical, psychological and health requirements for their staff within their Safety Management System.

Medical examinations as specified in Subsection 4.7.4 and any associated decisions on the individual fitness of staff must be conducted by a recognised occupational doctor.

Staff must not perform safety critical work whilst vigilance is impaired by substances such as alcohol, drugs or psychotropic medication. Therefore, Railway Undertakings and Infrastructure Managers shall have procedures in place to control the risk that staff attend for work under the influence of such substances, or consume such substances at work.

National rules of the Member State where a train service is operated apply with regard to defined limits of the above mentioned substances.

4.7.2. Recommended criteria for approval of occupational doctors and medical organisations

Railway Undertakings and Infrastructure Managers should select occupational doctors and organisations involved in medical examinations in accordance with the national rules and practices of the country in which the Railway Undertaking or Infrastructure Manager is licensed or registered.

Occupational doctors performing medical examinations as specified in Subsection 4.7.4 should have the following:

- Expertise in occupational medicine;
- Knowledge of the hazards of the work concerned and of the railway environment;
- An understanding of how measures intended to eliminate or reduce the risks from those hazards could be affected by lack of medical fitness.

The occupational doctor complying with these criteria may seek external medical or paramedical assistance to support his or her medical consultation and assessment, e. g. ophthalmologists.

4.7.3. Criteria for approval of psychologists involved in psychological assessment and psychological assessment requirements

4.7.3.1. Certification of psychologists

It is recommended that the psychologist should hold the relevant university qualification and be certified and recognised as competent according to national rules and practices of the country in which the Railway Undertaking or Infrastructure Manager is licensed or registered.

4.7.3.2. Content and interpretation of psychological assessment

The content and the procedure for interpretation of the psychological assessment shall be determined by a person certified according to section 4.7.3.1, taking account of the railway work and environment.

4.7.3.3. Selection of assessment tools

The assessment shall only include assessment tools that are based on psychological-scientific principles.

4.7.4. Medical examinations and psychological assessments

4.7.4.1. Before appointment

4.7.4.1.1. Minimum content of the medical examination

Medical examinations shall cover:

- General medical examination;
- Examinations of sensory functions (vision, hearing, colour perception);
- Urine or blood analysis for the detection of diabetes mellitus and other conditions as indicated by the clinical examination;
- Screening for drugs of abuse.

4.7.4.1.2. Psychological assessment

The aim of the psychological assessment is to support the Railway Undertaking in the appointment and management of staff who have the cognitive, psychomotor, behavioural and personality capabilities to perform their roles safely.

In determining the content of the psychological assessment the psychologist shall, as a minimum, take the following criteria into account relevant to the requirements of each safety function:

- Cognitive:
 - Attention and concentration
 - Memory
 - Perceptive capability
 - Reasoning
 - Communication
- Psychomotor:
 - Speed of reaction
 - Gestured co-ordination
- Behavioural and personality:
 - Emotional self control
 - Behavioural reliability
 - Autonomy
 - Conscientiousness

If the psychologist omits any of the above, the respective decision must be justified and documented.

4.7.4.2. After appointment

4.7.4.2.1. Periodicity of periodic medical examinations

At least one systematic medical examination shall be performed:

- Every 5 years for staff aged up to 40;
- Every 3 years for staff aged between 41 and 62;
- Every year for staff aged over 62.

Increased periodicity of examination shall be set by the occupational doctor if the state of health of the member of the staff requires so.

4.7.4.2.2. Minimum content of the periodic medical examination

If the worker complies with the criteria required at the examination, which is carried out before practising an occupation, the periodic specialised examinations must include as a minimum:

- General medical examination;
- Examination of sensory functions (vision, hearing, colour perception);
- Urine or blood analysis for the detection of diabetes mellitus and other conditions as indicated by the clinical examination;
- Screening for drugs of abuse where clinically indicated.

4.7.4.2.3. Additional medical examinations and/or psychological assessments

Besides the periodic medical examination, an additional specific medical examination and/or psychological assessment shall be performed where there is reasonable ground for doubting the medical or psychological fitness of a member of staff or reasonable suspicion of use of drugs of abuse or abuse or inappropriate use of alcohol. This would be the case especially after an incident or accident caused by human error on the part of the individual.

The employer must request a medical examination after any sickness absence exceeding 30 days. In suitable cases such an examination can be limited to an assessment by the occupational doctor based on available medical information indicating that the employee's fitness for work has not been affected.

Railway Undertakings and Infrastructure Managers must put systems in place to ensure that such additional examinations and assessments are undertaken as appropriate.

4.7.5. Medical requirements

4.7.5.1. General requirements

Staff shall not suffer from medical conditions or take medical treatment likely to cause:

- Sudden loss of consciousness;
- Impairment of awareness or concentration;
- Sudden incapacity;
- Impairment of balance or co-ordination;
- Significant limitation of mobility.

The following vision and hearing requirements must be met:

4.7.5.2. Vision requirements

- Aided or unaided distance visual acuity: 0.8 (right eye + left eye — measured separately); Minimum of 0.3 for the worse eye.
- Maximum corrective lenses: hypermetropia + 5/myopia – 8. The recognised occupational doctor (as defined in Subsection 4.7.2) may allow values outside this range in exceptional cases and after having sought the opinion of an eye specialist.
- Intermediate and near vision: sufficient whether aided or unaided.
- Contact lenses are allowed.
- Normal colour vision: using a recognised test, such as the Ishihara, completed by another recognised test if required.
- Vision field: normal (absence of any abnormality affecting the task to be performed)
- Vision for both eyes: present
- Binocular vision: present
- Contrast sensitivity: good
- Absence of progressive eye disease
- Lens implants, keratomies and keratectomies are allowed only on condition that they are checked on a yearly basis or according to a periodicity set by the occupational doctor.

4.7.5.3. Hearing requirements

Sufficient hearing confirmed with tone audiogram, that is:

- Hearing good enough to keep a phone conversation going and be able to hear alert tones and radio messages;
- The following values given for information should be taken as guidelines;
- The hearing deficiency must not be higher than 40 dB at 500 and 1 000 Hz;
- The hearing deficiency must not be higher than 45 dB at 2 000 Hz for the ear with the worst air conduction of sound.

4.7.5.4. Pregnancy

Pregnancy shall be considered a temporary cause for exclusion as regards drivers in the event of poor tolerance or pathological condition. The employer shall ensure that the legal provisions protecting pregnant workers are applied.

4.7.6. Specific requirements regarding the task of driving a train

4.7.6.1. Periodicity of periodic medical examinations

In respect to staff undertaking the task of driving a train, Subsection 4.7.4.2.1 of this TSI is modified as follows:

‘At least one systematic medical examination must be performed:

- Every 3 years for staff aged up to 60;
- Every year for staff aged over 60.’

4.7.6.2. Additional content of medical examination

Regarding the task of train driving the medical examination before appointment as well as each periodic medical examination concerning staff aged 40 and older must additionally involve monitoring by ECG at rest.

4.7.6.3. Additional vision requirements

- Aided or unaided distance visual acuity 1.0 (binocularly); at least 0.5 for the worse eye.
- Coloured contact lenses and photochromatic lenses are not allowed. UV filter lenses are allowed.

4.7.6.4. Additional hearing and speaking requirements

- No anomaly of the vestibular system.
- No chronic speech disorder (given the necessity to exchange messages loudly and clearly).
- Hearing requirements as set out in Subsection 4.7.5.3 must be achieved without the use of hearing aids. However, subject to medical opinion, the use of hearing aids is allowed in special cases.

4.7.6.5. Anthropometrics

The anthropometric measures of staff must be suitable for the safe use of the rolling stock. Drivers must not be required or allowed to operate particular types of rolling stock if their height, weight or other physical characteristics would make this unsafe.

4.7.6.6. Trauma Counselling

Staff who, while performing the task of driving a train, are affected by traumatising accidents causing death or serious injuries of persons, shall be subject to appropriate care by the employer.

4.8. **Infrastructure and Rolling stock registers**

In accordance with Article 22a(1) of Directive 96/48/EC, 'the Member States shall ensure that registers of infrastructure and of rolling stock are published and updated annually. Those registers shall indicate the main feature of each subsystem or part subsystem involved and their correlation with the features laid down by the applicable TSIs. To that end, each TSI shall indicate precisely which information must be included in the registers of infrastructure and of rolling stock.'

Due to the annual update and publication of these registers they are not suitable for the particular requirements of the 'Traffic Operations and Management' subsystem. Therefore this TSI specifies nothing in respect of these registers.

However, there is an operational requirement for certain infrastructure related data items to be made available to a Railway Undertaking and conversely for certain rolling stock related items to be made available to an Infrastructure Manager. In both cases the data concerned shall be complete and accurate.

4.8.1. Infrastructure

The requirements for the high speed rail infrastructure related data items with regard to the Traffic Operation and Management subsystem, and which must be made available to railway undertakings, are specified in Annex D. The Infrastructure Manager is responsible for the correctness of the data.

4.8.2. Rolling stock

The following rolling stock related data items shall be available to infrastructure managers. The keeper (vehicle owner) is responsible for the correctness of the data:

- whether the vehicle is constructed from materials which can be hazardous in case of accidents or fire (e.g. asbestos)
- length over buffers.

5. INTEROPERABILITY CONSTITUENTS

5.1. Definition

According to Article 2(d) of Directive 96/48/EC:

Interoperability constituents are 'any elementary component, group of components, subassembly or complete assembly of equipment incorporated or intended to be incorporated into a subsystem upon which the interoperability of the trans-European high speed rail system depends directly or indirectly. The concept of a constituent covers both tangible objects and intangible objects such as software'.

An interoperability constituent is:

- a product which can be placed on the market before integration and use in the subsystem; in this respect, it shall be possible to verify its conformity independently of the subsystem into which it will be incorporated,
- or an intangible object such as software or a process, organisation, procedure, etc. which has a function in the subsystem and the conformity of which shall be verified to ensure that the essential requirements are met.

5.2. List of constituents

The interoperability constituents are covered by the relevant provisions of Directive 96/48/EC. In respect to the Traffic Operation and Management Subsystem, there are, at present, no interoperability constituents.

5.3. Constituents' performances and specifications

Not applicable

6. ASSESSMENT OF CONFORMITY AND/OR SUITABILITY FOR USE OF THE CONSTITUENTS AND VERIFICATION OF THE SUBSYSTEM

6.1. Interoperability constituents

As this TSI does not yet specify any interoperability constituents no assessment arrangements are discussed.

If however interoperability constituents are subsequently defined and therefore able to be assessed by a Notified Body, the relevant assessment procedure(s) may then be added to a revised version.

6.2. Traffic Operation and Management Subsystem

6.2.1. Principles

The Traffic Operation and Management subsystem is a structural subsystem according to annex II to Directive 96/48/EC.

However, the individual elements are closely aligned with the operational procedures and processes required from an Infrastructure Manager or Railway Undertaking for the granting of a safety authorisation/certificate under the terms of the Directive 2004/49/EC. The Railway Undertaking or Infrastructure Manager shall demonstrate compliance with the requirements of this TSI. They can do this as part of the Safety Management System as described in Directive 2004/49/EC. It should be noted that at present none of the elements contained within this TSI require separate assessment by a Notified Body.

The relevant Competent Authority shall carry out an assessment of any new or amended operational procedures and processes, prior to implementation, before granting a new or revised safety authorisation/certificate. This assessment shall be a part of the process for granting the safety certificate/authorisation. Where the scope of this SMS will impact on another Member State(s), co-ordination with that Member State in respect to assessment should be ensured.

Subject to satisfactory completion of the assessment process described below, the Competent Authority shall authorise the Infrastructure Manager or Railway Undertaking to implement the relevant elements of its Traffic Operation and Management System in conjunction with the granting of the Safety Authorisation or Safety Certificate required by Articles 10 and 11 of Directive 2004/49/EC.

Wherever an Infrastructure Manager or Railway Undertaking introduces new/upgraded/renewed operational process(es) (or materially changes existing ones) covered by the requirements of this TSI, then they shall draw up a commitment indicating that such process(es) is(are) in compliance with the Traffic Operation and Management TSI (or a part of it in the transitional period — see Chapter 7).

The assessment process of new or amended operational procedures and processes as described in this chapter is equivalent to the authorisation of placing in service delivered by the Member State in accordance with Article 14(1) of Directive 96/48/EC.

6.2.2. Rules and procedures documentation

In respect to the assessment of the documentation described in Subsection 4.2.1 of this TSI, assurance that the process for preparing the content of the documentation provided by both Infrastructure Manager and Railway Undertaking is complete and accurate is the responsibility of the Competent Authority.

6.2.3. Assessment procedure

6.2.3.1. Decision by Competent Authority

In conjunction with Annex G, Infrastructure Managers and Railway Undertakings shall submit a description of any proposed new or amended operational process(es).

In respect to those items shown as being under Part A of the Safety Certificate/Authorisation as defined by Directive 2004/49/EC, these shall be presented to the Competent Authority of the Member State in which the company is established.

In respect to items shown as being under Part B of the Safety Certificate/Authorisation as defined by Directive 2004/49/EC, these shall be presented to the Competent Authority of each Member State concerned.

This shall be provided in sufficient detail to allow the Competent Authority(ies) to make a judgement as to whether a formal assessment will be required.

6.2.3.2. If an assessment is required

Where the Competent Authority(ies) decide(s) that such an assessment is required, then this shall be carried out as part of the assessment leading to granting/renewal of the safety certificate/authorisation in conformity with Directive 2004/49/EC.

The assessment procedures shall be in compliance with the Common Safety Method to be established for assessment and certification/authorisation of Safety Management Systems required by Articles 10 and 11 of Directive 2004/49/EC.

Some informative and not mandatory guidelines as to how this assessment could be conducted are contained in Annex F.

6.2.4. System performance

Article 14 paragraph 2 of Directive 96/48/EC requires Member States to check at regular intervals that interoperability subsystems are being operated and maintained in accordance with the essential requirements. In respect to the Traffic Operation and Management subsystem, such checks will be conducted in conformity with Directive 2004/49/EC.

7. IMPLEMENTATION

7.1. Principles

Implementation of this TSI and conformity with the relevant sections of this TSI must be determined in accordance with an implementation plan that shall be drawn up by each Member State for the High Speed lines for which they are responsible.

This plan must take into account:

- The specific human factors issues associated with operating any given line;
- The individual operating and safety elements of each line involved; and
- Whether implementation of the element(s) under consideration is to be:
 - only for certain High Speed lines,
 - applicable on all High Speed lines,
 - applicable to all trains, as described in Chapter 1.1 of this TSI, running on High Speed lines
- the relationship with implementation of other subsystems (CCS, RST, INS, ENE, ...);

At this time any specific exceptions that may be applicable should be taken into account and documented as part of the plan.

The implementation plan shall take into account the various levels of potential for implementation from whenever:

- a Railway Undertaking or Infrastructure Manager commences operations, or
- a renewal or upgrade to the existing operational systems of a Railway Undertaking or Infrastructure Manager is introduced, or
- new or upgraded infrastructure, energy, rolling stock or command control & signalling subsystems, requiring a corresponding set of operating procedures, are put into service.

Where upgrades to existing operational systems affect both Infrastructure Manager(s) and Railway Undertaking(s), the Member State is responsible for ensuring that such projects are assessed and placed into service coincidentally.

It is commonly understood that the full implementation of all elements of this TSI cannot be complete until the hardware (infrastructure, control and command, etc.) that is to be operated has been harmonised. The guidelines set out in this chapter shall therefore only be seen as an interim phase supporting migration to the target system.

In conformity with Articles 10 and 11 of Directive 2004/49/EC, the certification/authorisation is required to be renewed every 5 years. Once this revised TSI has been put into force and as part of the review process leading to this certification/authorisation renewal, Railway Undertakings and Infrastructure Managers must be able to demonstrate that they have taken the contents of this TSI into account and provide justification for any elements of it with which they do not yet comply.

Whilst full compliance with the target system described in this TSI is clearly the ultimate position, migration may be done in stages through the development of national or international, bilateral or multilateral agreements. Such agreements, which may be drawn up by and between a combination of IM-IM, IM — RU, RU — RU, shall always involve input from the Safety Authorities concerned.

Where existing agreements contain requirements related to traffic operation and management, then Member States shall notify the Commission, within 6 months after the entry into force of this TSI, of the following agreements:

- (a) national, bilateral or multilateral agreements between Member States and Railway Undertakings or Infrastructure Managers, agreed on either a permanent or a temporary basis and required due to the very specific or local nature of the intended train service;
- (b) bilateral or multilateral agreements between Railway Undertakings, Infrastructure Managers or Member States which deliver significant levels of local or regional interoperability;
- (c) international agreements between one or more Member States and at least one third country, or between Railway Undertakings or Infrastructure Managers of Member States and at least one Railway Undertaking or Infrastructure Manager of a third country, which deliver significant levels of local or regional interoperability.

The compatibility of these agreements with EU legislation, including their non-discriminatory character and, in particular, this TSI, will be assessed and the Commission will take the necessary measures such as the revision of this TSI to include possible specific cases or transitional measures.

The RIC agreements and the COTIF instruments shall not be notified, because they are known.

Renewal of such agreements shall be possible, but only in the interests of continued through working arrangements and only when no other suitable alternatives exist. Any modification of existing agreements or any future agreement shall take into account EU legislation and, in particular, this TSI. Member States shall notify the Commission of such modifications or new agreements. The same procedure as shown above shall then apply.

7.2. **Implementation guidelines**

The table shown in Annex N, which is informative and not mandatory, has been prepared as a guide to what the Member State could identify as the trigger for implementation of each of the elements in Chapter 4.

There are three distinct elements to implementation:

- Confirmation that any existing systems and processes comply with the requirements of this TSI
- Adaptation of any existing systems and processes to comply with the requirements of this TSI
- New systems and processes arising from implementation of other sub-systems
 - New/upgraded high speed lines (INS/ENE)
 - New or upgraded ETCS signalling installations, GSM-R radio installations, Hot Axle Box Detectors, ... (CCS)
 - New rolling stock (RST)

7.3. **Specific cases**

7.3.1. Introduction

The following special provisions are permitted in the specific cases below.

These specific cases belong to two categories:

- the provisions apply either permanently (case 'P'), or temporarily (case 'T').
- In temporary cases, it is recommended that the Member States concerned should conform with the relevant subsystem either by 2010 (case 'T1'), an objective set out in Decision No 1692/96/EC of the European Parliament and of the Council of 23 July 1996 on Community guidelines for the development of the trans-European transport network, or by 2020 (case 'T2').

7.3.2. List of specific cases

Temporary Specific Case (T2) Ireland

For the implementation of annex P of this TSI in the Republic of Ireland, vehicles, which are used solely in domestic traffic, may be exempted from carrying the standard 12-digit number. This may also apply for cross-border traffic between Northern Ireland and the Republic of Ireland.

Temporary Specific Case (T2) UK

For the implementation of annex P of this TSI in United Kingdom, passenger coaches and locomotives, which are used solely in domestic traffic, may be exempted from carrying the standard 12-digit number. This may also apply for cross-border traffic between Northern Ireland and the Republic of Ireland.

ANNEX A

ERTMS/ETCS and ERTMS/GSM-R operating rules

This Annex contains the rules for ERTMS/ETCS and ERTMS/GSM-R as they appear in version 1 (document published on the European Railway Agency Internet site www.era.europa.eu).

ANNEX B

Other rules enabling a coherent operation of new structural subsystems

(see also section 4.4)

This Annex will evolve over a period of time and will be subject to regular review and update.

Typical content of this Annex will be rules and procedures which are to be applied in an identical way across the entire TEN and the high speed network in particular and which are not today covered in Chapter 4 of this TSI. It is also likely that some elements of Chapter 4 and associated annexes will also be integrated into this Annex.

A. GENERAL**A1. Train Staffing**

Reserved

B. STAFF SAFETY AND SECURITY

Reserved

C. OPERATIONAL INTERFACE WITH SIGNALLING AND COMMAND AND CONTROL EQUIPMENT**C1. Sanding**

The application of sand is an effective way of improving the adhesion of wheels to the rail, to aid braking and starting away especially in conditions of inclement weather.

A build-up of sand on the railhead can however, cause a number of problems, especially in connection with the activation of track circuits and the effective operation of points and crossings.

The driver must always be able to apply sand but this must be avoided wherever possible:

- in the area of points and crossings
- during braking at speeds less than 20 km/h.

These restrictions are nevertheless not applicable if there is a risk of SPAD, or other serious incident and the application of sand would assist adhesion.

- when at a standstill. The exception to this is when starting away and when required to test the sanding equipment on the traction unit. (Testing should normally be undertaken in areas specifically designated in the Infrastructure Register).

C2. Activation of Hot Axle Box Detectors

Reserved

D. TRAIN MOVEMENTS**D1. Normal conditions****D2. Degraded conditions**

Reserved

E. ANOMALIES, INCIDENTS AND ACCIDENTS

Reserved

ANNEX C

Safety related communications methodology

Introduction

The purpose of this document is to set out the rules for safety-related ground-to-mobile and mobile-to-ground communications applicable to information transmitted or exchanged for safety critical situations on the interoperable network and in particular to:

- define the nature and structure of the safety-related messages;
- define the methodology for voice transmission of those messages.

This annex is to serve as the basis:

- to enable the Infrastructure Manager to draw up the messages and Books of Forms. These elements shall be addressed to the Railway Undertaking at the same time as the rules and regulations are made available;
- for the Infrastructure Manager and the Railway Undertaking to draw up the documents for their staff (Books of Forms), instructions for staff authorising train movements and Appendix 1 to the Driver's Rule Book 'Manual of communication procedures'.

The extent to which forms are used and their structure may vary. For some risks the use of forms will be appropriate, whilst for others it will not be appropriate.

In the context of a given risk, the Infrastructure Manager shall, acting in compliance with Article 9(3) of 2004/49/EC, decide whether the use of a form is appropriate. A form should only be used if the value of its safety and performance benefits exceeds that of any safety and performance disbenefits.

The Infrastructure Managers must structure his communications protocol in a formalised way and in line with the following 3 categories:

- urgent (emergency) verbal messages;
- written orders;
- additional performance messages;

To support the disciplined approach to transmission of these messages a Communications Methodology has been developed.

1. Communications methodology**1.1. Elements and principles of the methodology****1.1.1. Standard terminology to be used in the procedures****1.1.1.1. Speech transmission procedure**

Term transferring the opportunity to speak to the opposite party:

over

1.1.1.2. Message receiving procedure

- upon receiving a direct message

Term confirming that the sent message has been received:

received

Term used to have the message repeated in the event of poor reception or misunderstanding

say again (+ speak slowly)

- upon reception of a message that has been read-back

Terms used to ascertain whether a read-back message exactly matches the sent message:

correct

or not:

error (+ I say again)

1.1.1.3. Communications breaking procedure

- if the message has ended:

out

- if break is temporary and does not break the connection

Term used to keep the other party waiting:

wait

- if break is temporary but the connection is broken

Term used to tell the other party that the communication is going to be broken but will be resumed later on:

I call again

1.1.1.4. Cancelling a written order

Term used to cancel the written order procedure underway:

cancel procedure

If the message is then to subsequently be resumed, the procedure shall be repeated from the start.

1.1.2. Principles to be applied in the event of error or misunderstanding

To permit the correction of possible errors during communication, the following rules shall be applied:

1.1.2.1. Errors

— **error during transmission**

When a transmission error is discovered by the sender himself, the sender must request cancellation by sending the following procedure message:

error (+ prepare new form ...)

or:

error + I say again

and then send the initial message again.

— **error during read-back**

When the sender discovers an error whilst the message is being read back to him, the sender shall send the following procedure messages:

error + I say again

and send the initial message again.

1.1.2.2. Misunderstanding

If one of the parties misunderstands a message he must ask the other party to repeat the message by using the following text:

say again (+ speak slowly)

1.1.3. Word, number, time, distance, speed and date spelling code

To aid in understanding and expressing messages in different situations, each term must be pronounced slowly and correctly by spelling out any words or names and figures likely to be misunderstood. Examples would be the identifying codes for signals or points.

The following spelling rules shall apply:

1.1.3.1. Spelling out of words and letter groups

The International Phonetic Alphabet shall be used.

A	Alpha	G	Golf	L	Lima	Q	Quebec	V	Victor
B	Bravo	H	Hotel	M	Mike	R	Romeo	W	Whisky
C	Charlie	I	India	N	November	S	Sierra	X	X-ray
D	Delta	J	Juliet	O	Oscar	T	Tango	Y	Yankee
E	Echo	K	Kilo	P	Papa	U	Uniform	Z	Zulu
F	Foxtrot								

Example:

Points A B = points alpha-bravo.

Signal Number KX 835 = signal Kilo X-Ray eight three five.

The Infrastructure Manager may add further letters, along with a phonetic pronunciation for each letter added, if required by the alphabet of the Infrastructure Manager's operating language(s).

The Railway Undertaking may add further indications about pronunciation, as it deems necessary.

1.1.3.2. Expression of numbers

Numbers shall be spoken digit by digit.

0	Zero	3	Three	6	Six	9	Nine
1	One	4	Four	7	Seven		
2	Two	5	Five	8	Eight		

Example: train 2183 = train two-one-eight-three.

Decimals shall be expressed by the word 'point'.

Example: 12,50 = one-two-point-five-zero

1.1.3.3. Expression of time

The time shall be given in local time, in plain language.

Example: 10:52 hours = ten fifty-two.

Whilst this is the principle, it would also be acceptable, whenever necessary, for the time to be spelled out digit by digit (one zero five two hours).

1.1.3.4. Expression of distances and speeds

Distances shall be expressed in kilometres and speeds in kilometres per hour.

Miles may be used if that unit is used on the infrastructure concerned.

1.1.3.5. Expression of dates

Dates shall be expressed in the usual manner.

Example: 10 December

1.2. *Communications structure*

The voice transmission of safety-related messages shall in principle comprise 2 phases as follows:

- identification and request for instructions;
- transmission of the message itself and termination of the transmission.

The first phase may be cut back or entirely skipped for top priority safety messages.

1.2.1. Rules for identification and requests for instruction

To enable the parties to identify one another, define the operational situation and transmit procedural instructions, the following rules shall apply:

1.2.1.1. Identification

It is very important that before each communication, other than very urgent top priority safety messages, the persons who are going to communicate identify themselves. Not only is this a polite thing to do it, more importantly, provides a confidence that the person authorising train movements is in communication with the driver of the correct train and the driver knows he is speaking with the correct signalling or control centre. This is especially critical when communication is taking place in areas where communications boundaries overlap.

This principle shall apply even after an interruption during transmission.

The following messages shall be used for this purpose by the different parties.

— by the staff authorising train movements:

train <div style="text-align: center;">(number)</div> this is Signals <div style="text-align: center;">(name) </div>
--

— by the driver:

..... Signals <div style="text-align: center;">(name)</div> this is train <div style="text-align: center;">(number) </div>
--

It should be noted that the identification may be followed by an additional information message giving the staff authorising train movements enough details of the situation to determine precisely the procedure that the driver may subsequently be required to follow.

1.2.1.2. Request for instructions

Every application of a procedure supported by a written order must be preceded by a request for instructions.

The following terms shall be used to request instructions:

prepare procedure

1.2.2. Rules for transmission of written orders and verbal messages

1.2.2.1. Top priority safety messages

Due to their urgent and imperative nature, these messages:

- may be sent or received while running;
- may skip the identification part;
- shall be repeated;
- shall, as soon as possible, be followed by further information.

1.2.2.2. Written Orders

In order to reliably send or receive (at a standstill) the procedural messages contained in the Book or Forms, the following rules shall be followed:

1.2.2.2.1. Message sending

The form may be completed prior to transmitting the message so that the full text of the message can be sent in one single transmission.

1.2.2.2.2. Message receiving

The receiver of the message must fill in the form contained in the Book of Forms based upon the information given by the sender.

1.2.2.2.3. Read-back

All the messages in the Book of Forms shall be read back.

1.2.2.2.4. Acknowledgement of correct read-back

Every read-back message shall be followed by an acknowledgement of conformity or non-conformity given by the sender of the message.

correct

or

error + I say again

followed by a repeat sending of the initial message

1.2.2.2.5. Acknowledgement

Every message received shall be acknowledged positively or negatively as follows:

received

or

negative, say again (+ speak slowly)

1.2.2.2.6. Traceability and verification

A unique identification or authorisation number shall accompany all messages initiated from the ground:

- if the message concerns an action for which the driver requires a specific authorisation (e.g. passing a signal at danger,):

Genehmigung
(number)

- in all other cases (e.g. proceeding with caution,):

message
(number)

1.2.2.2.7. Reporting Back

Every message comprising a request to 'report back' shall be followed by a 'report'.

1.2.2.3. Additional messages

Additional messages:

- shall be preceded by the identification procedure;
- shall be short and precise (limited wherever possible to information to be communicated and where it applies);
- shall be read back and followed by an acknowledgement of correct read-back, or not
- may be followed by a request for instructions or a request for further information.

1.2.2.4. Information messages with a variable non-predetermined content

Information messages with a variable content shall be:

- preceded by the identification procedure;
- prepared before sending;
- read back and followed by an acknowledgement of correct read-back, or not.

2. **Procedural Messages**

2.1. *Nature of the messages*

Procedural messages are used to send operational instructions associated with appropriate situations represented in the Driver's Rule Book.

They comprise the text of the message itself, corresponding to a situation, and a number identifying the message.

If the message requires the recipient to report back, the text of the report is also given.

These messages use predetermined wording prescribed by the Infrastructure Manager in his 'operating language' and they are presented in the form of pre-prepared forms in either paper format or in computer medium.

2.2. *Forms*

Forms are a formalised medium for communicating procedural messages. These messages are generally those associated with degraded working conditions. Typical examples would be the authority for a driver to pass a signal or an 'end of movement authority', the requirement to run at reduced speed in a particular area, or to examine the line. There may well be other circumstances that will require the used of such messages.

Their purpose is to:

- provide a common working document used in real-time by the staff authorising train movements and by the drivers;
- provide the driver (especially when working in an unfamiliar or rare environment) with a reminder of the procedure he will required to follow
- enable traceability of communications.

In order to identify the forms, a unique code word or number relating to the procedure should be developed. This could be based on the potential frequency that a form would be used. If, of all the forms being developed, the likelihood is that the one most often used is the one for passing a signal or EOA at danger, then this one could be numbered 001 and so on.

2.3. *Book of Forms*

Having identified all the forms to be used, the whole set must be collected into a document or a computer medium called the Book of Forms.

It is a joint document that will be used by the driver and the staff authorising the movement of trains when they communicate with each other. It is important therefore that the book used by the driver and the one used by the staff authorising the movement of trains are constructed and numbered in the same manner.

The Infrastructure Manager is responsible for drawing up the Book of Forms and the forms themselves in his 'operating language'.

The Railway Undertaking may add translations of the forms and associated information contained in the Book of Forms, if he thinks that would help his drivers both during training and in real-time situations.

The language to be used when transmitting the messages shall always be the 'operating language' of the Infrastructure Manager.

The Book of Forms shall comprise two parts.

- The first part contains the following items:
 - a reminder about the utilisation of the Book of Forms;
 - an index of ground-originated Procedure Forms;
 - an index of driver-originated Procedure Forms, where appropriate;
 - the list of situations cross-referencing to which procedure form is to be used;
 - a glossary giving the situations to which each procedure form applies;
 - the code for spelling out messages (phonetic alphabet etc.).

The second part contains the Procedure Forms themselves.

Several examples of each form should be included in the Book of Forms and it is suggested that dividers should be used to separate the sections.

The Railway Undertaking may include explanatory text relevant to each form and the situations covered, in the drivers' Book of Forms.

3. **Additional messages**

Additional messages are information messages used either:

- by the driver to inform the staff authorising train movements or
- by the staff authorising train movements to advise the driver

of situations of a rare nature and for which therefore a pre-determined form is considered unnecessary, or related to train running or to the technical condition of the train or the infrastructure.

To make it easier to describe the situations and construct the information messages, message guidelines, a glossary of railway terminology, a descriptive diagram of the rolling stock being employed and a descriptive statement of the infrastructure equipment (track, traction supply, etc.) might be beneficial.

3.1. Guideline structure for messages

These messages may be structured along the following lines:

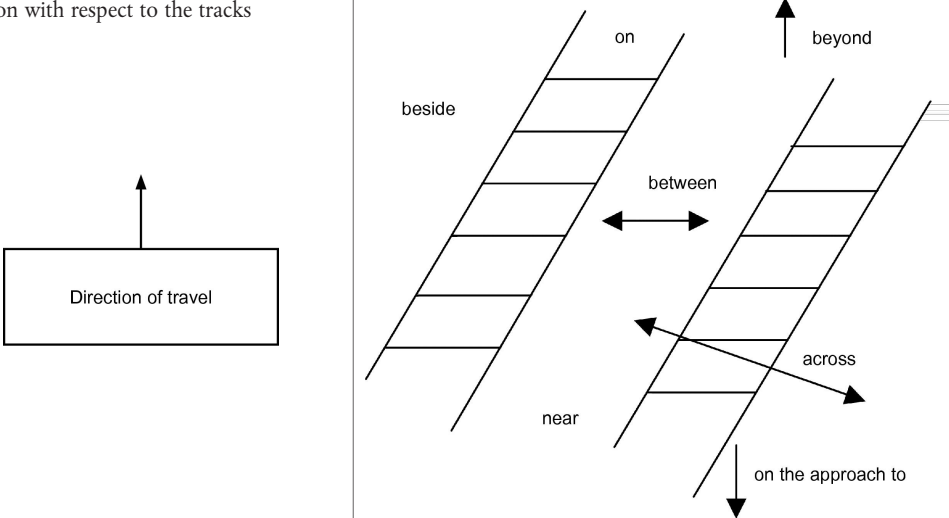
Stage in the communication flow	Message element
Reason for passing the information	<input type="checkbox"/> for information <input type="checkbox"/> for action
Observation	<input type="checkbox"/> There is <input type="checkbox"/> I saw <input type="checkbox"/> I had <input type="checkbox"/> I hit
Position — along the line	<input type="checkbox"/> at (station name) <input type="checkbox"/> (characteristic point) <input type="checkbox"/> at mile post/kilometre point (number)
— in respect to my train	<input type="checkbox"/> power car (number) <input type="checkbox"/> trailer car (number)
Nature	
— object — person (see glossary)
State	
— static	<input type="checkbox"/> standing on <input type="checkbox"/> lying on <input type="checkbox"/> fallen on
— moving	<input type="checkbox"/> walking <input type="checkbox"/> running <input type="checkbox"/> towards
Location with respect to the tracks	

These messages may be followed by a request for instructions.

The elements of the messages are provided in both the language chosen by the Railway Undertaking and in the operating language(s) of the Infrastructure Managers concerned.

3.2. *Glossary of Railway Terminology*

The Railway Undertaking shall produce a glossary of railway terminology for each network over which his trains operate. It shall supply the terms in regular use in the language chosen by the Railway Undertaking and in the 'operating' language of the Infrastructure Manager(s) whose infrastructure is worked over.

The glossary shall be composed of two parts:

- a listing of terms by subject matter;
- a listing of the terms in alphabetical order.

3.3. *Descriptive diagram of the rolling stock*

If the Railway Undertaking feels it would benefit his operation a descriptive diagram of the rolling stock used shall be prepared. It should list the names of the various components that may be the subject of communications with the different Infrastructure Managers concerned. It should include the common names for the standard terms in the language chosen by the Railway Undertaking and in the 'operating' language of the Infrastructure Manager(s) whose infrastructure is worked over.

3.4. *Descriptive statement of the characteristics of the infrastructure equipment (track, traction supply, etc.)*

If the Railway Undertaking feels it would benefit his operation a descriptive statement of the characteristics of the infrastructure equipment (track, traction supply, etc.) on the route worked over shall be prepared. This shall show the names of the various components that may be the subject of communications with the Infrastructure Manager(s) concerned. It should include the common names for the standard terms in the language chosen by the Railway Undertaking and in the 'operating' language of the Infrastructure Manager(s) whose infrastructure is worked over.

4. **Type and structure of verbal messages**

4.1. *Emergency messages*

Emergency messages are intended to give urgent operational instructions that are directly linked with the safety of the railway.

To avoid any risk of misunderstanding, messages must always be repeated once.

Classified according to need, the main messages which can be sent are indicated hereafter.

The Infrastructure Manager may, in addition, define other emergency messages according to the needs of his operation.

Emergency messages may be followed by a Written Order (see Subsection 2).

The type of text that goes to form Emergency messages must be included in Appendix 1 'Manual of communications procedures' to the Driver's Rule Book and in the documentation issued to staff authorising train movements.

4.2. *Messages sent either by the ground or the driver*

- Need to stop all trains:

The need to stop all trains must be transmitted by means of an acoustic signal; if this is not available the following phrase must be used:

Emergency, stop all trains

Information on location or area is, if necessary, specified in the message.

In addition, this message is to be quickly complemented, if possible, by the reason, the location of the emergency and the train's identification:

<p>Obstruction Or Fire Or</p> <p style="text-align: center;"><i>(other reason)</i></p> <p>on line at (km)</p> <p style="text-align: center;"><i>(name)</i></p> <p>Driver of train</p> <p style="text-align: center;"><i>(number)</i></p>

— Need to stop a particular train:

<p>Train (on line/track)</p> <p style="text-align: center;"><i>(number)</i> <i>(name/number)</i></p> <p>Emergency stop</p>
--

In this circumstance the name or number of the line or track on which the train is running may be used to complement this message.

4.3. Messages issued by the driver

— Need to cut the traction power supply:

<p>Emergency current isolation</p>

This message is to be quickly complemented, if possible, by the reason, the location of the emergency and the train's identification:

<p>At</p> <p style="text-align: center;"><i>(km)</i></p> <p>on line/track</p> <p style="text-align: center;"><i>(name/number)</i></p> <p>between and</p> <p style="text-align: center;"><i>(station)</i> <i>(station)</i></p> <p>Reason</p> <p>Driver of train</p> <p style="text-align: center;"><i>(number)</i></p>

In this circumstance the name or number of the line or track on which the train is running may be used to complement this message.

ANNEX D

Information to which the Railway Undertaking must have access in connection with the route(s) over which he intends to operate

PART 1. GENERIC INFORMATION REGARDING THE INFRASTRUCTURE MANAGER

- 1.1. Name (s)/Identity of Infrastructure Manager(s)
- 1.2. Country (or Countries)
- 1.3. Brief description
- 1.4. List of general operational rules and regulations (and how to obtain them)

PART 2. MAPS AND DIAGRAMS

2.1. **Geographic map**

- 2.1.1. Routes
- 2.1.2. Principal locations (stations, yards, junctions, freight terminals)

2.2. **Line diagram**

Information to be included on diagrams, supplemented as necessary by text. Where a separate station/yard/depot diagram is provided then information on line diagram may be simplified

- 2.2.1. Indication of distance
- 2.2.2. Identification of running lines, loops, sidings and catch/trap points
- 2.2.3. Connections between running lines
- 2.2.4. Principal locations (stations, yards, junctions, freight terminals)
- 2.2.5. Location and meanings of all fixed signals

2.3. **Station/Yard/Depot diagrams (N.B. applies only to locations available to interoperable traffic)**

Information to be identified on location specific diagrams, supplemented as necessary by text

- 2.3.1. Name of location
- 2.3.2. Location identity code
- 2.3.3. Type of location (passenger terminal, freight terminal, yard, depot)
- 2.3.4. Location and meanings of all fixed signals
- 2.3.5. Identification and plan of tracks, including catch/trap points
- 2.3.6. Identification of platforms
- 2.3.7. Length of platforms
- 2.3.8. Height of platforms

- 2.3.9. Identification of sidings
- 2.3.10. Length of sidings
- 2.3.11. Availability of shore electric supply
- 2.3.12. Distance between the edge of the platform and the centre of the track, parallel to the running surface
- 2.3.13. (For passenger stations) Availability of access for disabled persons

PART 3. SPECIFIC LINE SEGMENT INFORMATION

3.1. **General Characteristics**

- 3.1.1. Country
- 3.1.2. Line segment identification code: national code
- 3.1.3. Line segment extremity 1
- 3.1.4. Line segment extremity 2
- 3.1.5. Times of opening for traffic (times, days, special arrangements for holidays)
- 3.1.6. Lineside indications of distance (frequency, appearance and positioning)
- 3.1.7. Type of traffic (mixed, passenger, freight, ...)
- 3.1.8. Maximum permissible speed(s)
- 3.1.9. Any other information which is necessary for safety reasons
- 3.1.10. Specific local operational requirements (including any special staff competences)
- 3.1.11. Special restrictions for dangerous goods
- 3.1.12. Special loading restrictions
- 3.1.13. Model of temporary works notice (and way to obtain it)
- 3.1.14. Indication that Line segment is congested (art. 22 of 2001/14/EC)

3.2. **Specific Technical Characteristics**

- 3.2.1. EC verification for Infrastructure TSI
- 3.2.2. Date of putting into service as an interoperable line
- 3.2.3. List of possible specific cases
- 3.2.4. List of possible specific derogations
- 3.2.5. Track gauge
- 3.2.6. Structure gauge
- 3.2.7. Maximum axle load
- 3.2.8. Maximum load per linear metre
- 3.2.9. Transversal track forces

- 3.2.10. Longitudinal track forces
- 3.2.11. Minimum radius of curvature
- 3.2.12. Gradient percentage
- 3.2.13. Gradient location
- 3.2.14. For brake system that does not use wheel-rail adhesion, accepted braking effort
- 3.2.15. Bridges
- 3.2.16. Viaducts
- 3.2.17. Tunnels
- 3.2.18. Comments

- 3.3. **Energy subsystem**
 - 3.3.1. EC verification for Energy TSI
 - 3.3.2. Date of putting into service as an interoperable line
 - 3.3.3. List of possible specific cases
 - 3.3.4. List of possible specific derogations
 - 3.3.5. Type of power supply system (e.g. none, overhead, 3rd rail)
 - 3.3.6. Power supply system frequency (e.g. AC, DC)
 - 3.3.7. Minimum voltage
 - 3.3.8. Maximum voltage
 - 3.3.9. Restriction related to power consumption of specific electric traction unit(s)
 - 3.3.10. Restriction related to the position of Multiple Traction unit(s) to comply with contact line separation (position of pantograph)
 - 3.3.11. How to obtain electrical isolation
 - 3.3.12. Contact wire height
 - 3.3.13. Permissible contact wire gradient in relation to the track and the variation of the gradient
 - 3.3.14. Type of pantographs approved
 - 3.3.15. Minimum static force
 - 3.3.16. Maximum static force
 - 3.3.17. Location of neutral sections
 - 3.3.18. Information on operation
 - 3.3.19. Lowering of pantographs
 - 3.3.20. Conditions applying with regard to regenerative braking
 - 3.3.21. Maximum allowable train current

3.4. Control-Command and Signalling subsystem

3.4.1. EC verification for CCS TSI

3.4.2. Date of putting into service as an interoperable line

3.4.3. List of possible specific cases

3.4.4. List of possible specific derogations

ERTMS/ETCS

3.4.5. Level of application

3.4.6. Optional functions installed lineside

3.4.7. Optional functions required on board

3.4.8. Software version number

3.4.9. Placing-in-service date of this version

ERTMS/GSM-R RADIO

3.4.10. Optional functions as specified in FRS

3.4.11. Version number

3.4.12. Placing-in-service date of this version

FOR ERTM/ETCS LEVEL 1 WITH INFILL FUNCTION

3.4.13. Technical implementation required for rolling stock

CLASS B TRAIN PROTECTION, CONTROL AND WARNING SYSTEM(S)

3.4.14. National rules for operating class B systems (+ way to obtain them)

LINE SYSTEM

3.4.15. Responsible Member State

3.4.16. System name

3.4.17. Software Version number

3.4.18. Placing-in-service date of this version

3.4.19. End of period of validity

3.4.20. Need for more than one system active simultaneously

3.4.21. On-board system

CLASS B RADIO SYSTEM

3.4.22. Responsible Member State

3.4.23. System name

3.4.24. Version number

3.4.25. Placing-in-service date of this version

- 3.4.26. End of period of validity
- 3.4.27. Special conditions to switch over between different class B train protection, control and warning systems
- 3.4.28. Special technical conditions required to switch over between ERTMS/ETCS and Class B Systems
- 3.4.29. Special conditions to switch over between different radio systems

TECHNICAL DEGRADED MODES OF:

- 3.4.30. ERTM/ETCS
- 3.4.31. Class B train protection, control and warning system
- 3.4.32. ERTM/GSM-R
- 3.4.33. Class B radio system
- 3.4.34. Line side signalling

SPEED RESTRICTIONS RELATED TO BRAKING PERFORMANCE

- 3.4.35. ERTM/ETCS
- 3.4.36. Class B train protection, control and warning systems

NATIONAL RULES FOR FUNCTIONING CLASS B SYSTEM

- 3.4.37. National rules linked to braking performance
- 3.4.38. Other national rules, e.g.: data corresponding with UIC leaflet 512 (8th edition of 1.1.79 and 2 Amendments)

EMC SUSCEPTIBILITY OF INFRASTRUCTURE-SIDE CONTROL-COMMAND AND SIGNALLING

- 3.4.39. Requirement to be specified according to European Standards
- 3.4.40. Permissibility to use Eddy-current brake
- 3.4.41. Permissibility to use magnetic brake
- 3.4.42. Requirements for technical solutions concerning implemented derogations

3.5. Traffic Operation and Management Subsystem

- 3.5.1. EC verification for OPE TSI
 - 3.5.2. Date of putting into service as an interoperable line
 - 3.5.3. List of possible specific cases
 - 3.5.4. List of possible specific derogations
 - 3.5.5. Language used for safety critical communications with infrastructure manager staff
 - 3.5.6. Special climatic conditions and associated arrangements
-

ANNEX E

Language and communication level

Oral competence in a language can be subdivided into five levels:

Level	Description
5	<ul style="list-style-type: none">— can adapt the way he/she speaks to any interlocutor— can put forward an opinion— can negotiate— can persuade— can give advice
4	<ul style="list-style-type: none">— can cope with totally unforeseen situations— can make assumptions— can express an argued opinion
3	<ul style="list-style-type: none">— can cope with practical situations involving an unforeseen element— can describe— can keep a simple conversation going
2	<ul style="list-style-type: none">— can cope with simple practical situations— can ask questions— can answer questions
1	<ul style="list-style-type: none">— can talk using memorised sentences

This annex is a provisional position. A more detailed piece of work is being prepared and will be available for a future revision of this TSI and which will match the proposals in the CR OPE TSI.

There are also plans to incorporate a tool to be used when assessing the level of competence of an individual. This will be made available in a future version of this TSI.

—

ANNEX F

Informative and not mandatory Traffic Operation and Management Subsystem assessment guidelines

(The use of the expression 'Member State' when taken in the context of this module means the Member State or other body appointed by them, undertaking the assessment.)

1. This annex sets out guidelines to facilitate assessments by Member States to confirm that the operational process(es) proposed:

- complies with this TSI and demonstrates that the essential requirements ⁽¹⁾ of Directive 96/48/EC (and any amendments included in Directive 2004/50/EC) have been met,
- complies with the other regulations as appropriate, including Directive 2004/49/EC,

and may be placed into service.

2. The Infrastructure Manager or Railway Undertaking concerned must supply the Member State with appropriate documentation (as described in clause 3 below) describing the new or amended operations process(es).

The documentation supplied about the conception and development of the new or amended operational process(es) must be sufficiently detailed so as to enable the Member State to understand the rationale behind the proposal. Additionally, where subsystems are being upgraded or renewed, the submission must also include feedback of operational experience.

The documentation may be supplied in either paper or computer medium format (or a combination of both). The Member State may request further copies if needed for carrying out the assessment.

3. Details of assessment

- 3.1. The documentation describing the operational process(es) concerned should contain at least the following elements:

- a general description of the Infrastructure Manager's or Railway Undertaking's operations organisation (overview of the management/supervision and functionality), together with a detail of the conditions and the framework within which the operations process(es) to be assessed shall be used and operated;
- details of all relevant operational processes required to be carried out (typically procedures, instructions, computer programs, etc.);
- a description of how the operations process(es) concerned shall be implemented, used and controlled, including an analysis of any specific equipment to be used;
- details of the people who will be affected by the operational process(es), the training and/or briefing that will take place and any assessment of risk to personal exposure to which the people might be subjected;
- a procedure for how subsequent amendments and updates to the operations process(es) will be managed (NOTE: this does not include any future major changes or new process(es) — in this case, a new submission under these guidelines would be applicable);
- diagram showing how necessary feedback information (and all other information relating to the operation) flows into, out of and around the Infrastructure Manager's or Railway Undertaking's operations organisation to support the relevant operation processes;

⁽¹⁾ The essential requirements are reflected in the technical parameters, interfaces and performance requirements set out in Chapter 4 of the TSI.

- descriptions, explanations and all the records necessary for understanding the conception and development of the new or amended operations process(es) concerned (NOTE: for Safety Critical processes, this should include an assessment of the risks associated with implementing the new/amended process(es));
- demonstration of compliance between of the operation process(es) concerned with the requirements of the TSI;

The following elements should also be supplied, where relevant:

- a list of the specifications or European standards, against which the relevant operation processes of the subsystem have been validated and the evidence of this conformity;
- evidence of conformity with other regulations deriving from the treaty (including certificates);
- specific conditions or restrictions of relevant operation processes

3.2. The Member State shall:

- identify the relevant provisions of the TSI, with which operations process(es) concerned must comply;
- check that the documentation supplied is complete and in accordance with clause 3.1;
- examine the documentation supplied and evaluate whether:
 - the operations process(es) concerned comply with the relevant requirements of the TSI;
 - the conception and development of the new or revised operations process(es) (including any assessment of risks) are robust and have been managed in a controlled manner;
 - the arrangements for implementation and subsequent use/control of the operations process(es) will ensure continued compliance with the relevant TSI requirements;
- document (in an assessment report, see Clause 4 below) its findings with regards to compliance of the operations process(es) with the TSI provisions.

4. The assessment report shall include at least the following information:

- details of the Infrastructure Manager/Railway Undertaking concerned,
- description of operations process(es) that have been assessed, including details of any specific procedures, instructions, computer programs concerned;
- description of those elements relating to the control and use of the operations process(es) concerned, including monitoring, feedback and adjustment,
- any subsidiary inspection and audit reports drawn up in connection with the assessment
- confirmation that the operations process(es) concerned and their conditions of implementation will ensure compliance with the appropriate requirements stated in the relevant sections of the TSI, including any reservations remaining at the conclusion of the assessment.
- A statement of any conditions and limits (including any appropriate restrictions to address any reservations) for implementing the relevant operations process(es),
- name and address of the Member State involved in the assessment and date of the completion of the report.

If the Infrastructure Manager/Railway Undertaking is denied authorisation/certification to implement the relevant operation processes on the basis of the assessment report, the Member State must provide detailed reasons for such denial in accordance with Directive 2004/49/EC.

ANNEX G

Informative and not mandatory List of elements to be verified for each basic parameter

This Annex is at an early stage of development and requires further work; it is included as a working draft.

In association with the certification and authorisation processes described in Articles 10 and 11 of Directive 2004/49/EC, this annex outlines the following supporting information:

- **A** — an item that is of an organisational or principals nature and should be included in the Safety Management System
- **B** — an item that is a detailed procedure or operational process in support of the organisational principals in the SMS and which is only applicable within the Member State

Parameters to be assessed	Elements to be verified for each parameter	TSI reference	Applicable to		A/B
			RU	IM	
Documentation for Drivers	Process for compilation of Driver's Rule Book (including language translation [where appropriate] and validation process)	4.2.1.2.1	X		A
	Process for IM to provide RU with appropriate information	4.2.1.2.1		X	A
	Content of Driver's Rule Book includes minimum requirements of this TSI and specific procedures required by IM	4.2.1.2.1	X		B
	Process for compilation of Driver's Route Book (and validation process)	4.2.1.2.2.1	X		A
	Content of Driver's Route Book includes minimum requirements of this TSI	4.2.1.2.2.1	X		B
	Process for IM to advise RU of changes to operational rules/information	4.2.1.2.2.2		X	A
	Process for grouping changes into a dedicated document	4.2.1.2.2.2	X		A
	Process for advising drivers in real time of changes	4.2.1.2.2.3		X	A
	Process for providing drivers with train schedule information	4.2.1.2.3	X		A
	Process for providing drivers with rolling stock information	4.2.1.2.4	X		A
	Process for compilation of location-specific rules and procedures (including validation process) <i>ground staff</i>	4.2.1.3	X		B
Documentation for IM's staff authorising train movements	Process for safety-related communication between IM and RU staff	4.2.1.4		X	A
Safety-related communication between RU and IM staff	Process for ensuring that staff apply the operational communication methodology as specified in annex C of this TSI	4.2.1.5, 4.6.1.3.1	X		A
				X	A
Train Visibility	Process for ensuring front end illumination of trains complies with the requirements of this TSI	4.2.2.1.2, 4.3.3.4.1	X		A

Parameters to be assessed	Elements to be verified for each parameter	TSI reference	Applicable to		A/B
			RU	IM	
Train Audibility	Process for ensuring audibility of trains complies with the requirements of this TSI	4.2.2.2, 4.3.3.5	X		A
Vehicle Identification	Process to demonstrate compliance with Annex P of this TSI	4.2.2.3	X		A
Requirements for passenger vehicles	Process to demonstrate compliance with the requirements of this TSI	4.2.2.4	X		A
Train composition	Process for compilation of Train Composition Rules (including validation process)	4.2.2.5	X		A
	Content of Train Composition Rules includes minimum requirements specified in this TSI	4.2.2.5	X		B
Braking requirements	Process for ensuring provision of route related information required for brake performance calculations or provision of the actual performance required	4.2.2.6.2		X	A
	Process for calculation or provision of brake performance required ('Braking Rules')	4.2.2.6.2, 4.3.2.1	X		B
Responsibility to ensure that the train is in running order	Definition of the safety-related on-train equipment required to ensure train safe to run	4.2.2.7.1	X		B
	Process for ensuring that any modification to the characteristics of the train affecting its performance are identified, and that this information is provided to IM	4.2.2.7.1	X		A
	Process to ensure that train running information is made available to IM prior to departure	4.2.2.7.2	X		A
Train Planning	Process of ensuring RU provides required data to IM when requesting a train path	4.2.3.1		X	A
Identification of Trains	Process for assigning unique and unambiguous train identification numbers	4.2.3.2		X	A
Departure Procedures	Definition of pre-departure checks and tests	4.2.3.3.1	X		B
	Process for reporting factors that could affect train running	4.2.3.3.2	X		A
Traffic Management	Provision of means of recording real time information, including minimum data required by this TSI	4.2.3.4.1		X	B
	Definition of procedures for control and supervision of traffic operation	4.2.3.4.2.1		X	B
	Process of ensuring management of changes in line conditions and train characteristics	4.2.3.4.2		X	B
	Process for indication of estimated time a train is to be handed over from IM to IM	4.2.3.4.2.2		X	B
Dangerous Goods	Process of ensuring supervision of dangerous goods, including minimum requirements of this TSI	4.2.3.4.3	X		A
Operational Quality	Process to monitor efficient operation of all concerned services and communicate trends to all relevant IMs and RUs	4.2.3.4.4	X		B
				X	B

Parameters to be assessed	Elements to be verified for each parameter	TSI reference	Applicable to		A/B
			RU	IM	
Data Recording	List of data to be recorded outside the train includes minimum list of items required by this TSI	4.2.3.5.1		X	A
	List of data to be recorded inside the train includes minimum list of items required by this TSI	4.2.3.5.2, 4.3.2.3	X		A
Degraded Operation	Process for informing other users of disturbances likely to cause disruption of services	4.2.3.6.2		X	A
			X		A
	Definition of instructions to be given from IM to train drivers in times of service disruption	4.2.3.6.3		X	B
	Definitions of appropriate measures to address service disruption scenarios identified, including minimum requirements listed in this TSI	4.2.3.6.4		X	B
Managing an Emergency Situation	Process to define and publish contingency measures to manage emergency services	4.2.3.7		X	A
	Process for provision of emergency and safety instructions for passengers	4.2.3.7	X		A
Aid to traincrew in the event of major incident	Process to assist traincrew in degraded situations in order to avoid delays	4.2.3.8	X		A
Professional and Linguistic Competence	Process for assessing professional knowledge according to minimum requirements of this TSI	4.6.1.1	X		A
				X	A
	Definition of competence management system to ensure staff's ability to put knowledge into practice according to minimum requirements of this TSI	4.6.1.2	X		A
				X	A
	Process for assessing linguistic ability to meet minimum requirements of this TSI	4.6.2	X		A
				X	A
	Definition of the assessment process for train crew, including: Basic competences, procedures and languages Route knowledge Rolling stock knowledge Special competence (e.g. long tunnels)	4.6.3.1, 4.6.3.2.3	X		A
				X	A
X				A	
Definition of a training and competence needs analysis for staff with safety-critical duties, to take into account minimum requirements of this TSI	4.6.3.2	X		A	
			X	A	

Parameters to be assessed	Elements to be verified for each parameter	TSI reference	Applicable to		A/B
			RU	IM	
Health and Safety Conditions	Process for ensuring medical fitness of staff, including controls of affects of drugs and alcohol on operational performance	4.7.1	X		A
				X	A
	Determination of criteria for: Approval of occupational doctors and medical organisations	4.7.2, 4.7.3, 4.7.4	X		A
	Approval of psychologists Medical and psychological examination			X	A
	Determination of medical requirements, including	4.7.5	X		A
	— General health				
	— Vision			X	A
— Hearing					
— Pregnancy (drivers)					
Special requirements for drivers:		4.7.6	X		A
— Vision					
— Hearing/speaking requirements					
— anthropometrics					

ANNEX H

Minimum elements relevant to professional competence for the task of driving a train**1. GENERAL REQUIREMENTS**

- This Annex, which must be read in conjunction with Subsections 4.6 and 4.7 of this TSI and the requirements of the SRT TSI, is a list of the elements that are deemed to be relevant to the task of driving a train on the high speed lines of the TEN.

It should be noted that whilst this document is as complete as it can be in terms of a generally applicable list, there will be additional items, of a local/national nature, that will also need to be considered.

- The expression 'professional competence', when taken within the context of this TSI, refers to those elements that are important to ensuring that operational staff are trained and able to understand and discharge the elements of the task.
- Rules and procedures apply to the task being performed and to the person carrying out the task. These tasks may be carried out by any authorised competent person irrespective of any name, job title or grade used in rules or procedures or by the individual company.
- Any authorised competent person must carry out all rules and procedures related to the task being performed.

2. PROFESSIONAL KNOWLEDGE

Any authorisation requires a successfully passed initial examination and provisions for ongoing assessment and training as described in Subsection 4.6.

2.1. General professional knowledge

- General principles of safety management within the railway system, relevant to the task, including interfaces with other subsystems
- General conditions relevant to the safety of passengers and/or cargo and persons on or about the railway track
- Conditions of health and safety at work
- General principles of security of the railway system
- Personal safety including when leaving the driving cab on the running line
- Train composition (*as required by the company*)
- Knowledge of electrical principles in respect to rolling stock and the infrastructure.

2.2. Knowledge of operational procedures and safety systems applied to the infrastructure to be used

- Operational procedures and safety rules
- Control command and signalling system including related cab signalling indications
- Regulations for train driving in normal, degraded and emergency conditions
- Communications protocol and formalised messaging procedure including use of communication equipment

- The different roles and responsibilities of persons involved in the operation process
- Documents and other information related to the task including additional advice on current conditions e.g. regarding speed limits or temporary signalling received before departure

2.3. Knowledge of rolling stock

- Traction unit equipment relevant to the driving task:
 - Constituent parts and their purpose
 - Communication and emergency equipment
 - Control devices and indicators placed at the disposal of the driver and which concern traction, braking and traffic safety related elements.
- Vehicle equipment relevant to the driving task:
 - Constituent parts and their purpose
 - Control devices and indicators placed at the disposal of the driver which concern braking and traffic safety related elements
 - Meaning of markings on the inside and outside of vehicles and the symbols used for the transportation on dangerous goods.

3. ROUTE KNOWLEDGE

Route knowledge comprises the specific knowledge and/or experience of the individual characteristics of a route that a driver needs to have before being permitted to drive a train over it on his own responsibility. It comprises the knowledge that is needed in addition to information given by signals and documents such as timetables and other on board documents and in addition to knowledge of operations and safety rules applying to the route and as specified in clause 2.2 of this Annex.

Route knowledge covers in particular:

- The conditions of operation such as: signalling and control and communications
- Knowledge of the location of signals, steep gradients, and level crossings
- Points of transition between different operating systems or power supplies
- The type of traction power supply on the line concerned including location of neutral sections
- Local operating and emergency arrangements
- Stations and stopping points
- Local installations (depots, sidings, ...) as required by the company.

4. ABILITY TO PUT THE KNOWLEDGE INTO PRACTISE

The staff undertaking train driving duties must be capable of carrying out the following tasks (as appropriate to the company's activities)

4.1. Prepare for duty

- Identify the characteristics of the work to be done including any corresponding documents
- Ensure that documents and necessary equipment are complete
- Verify any requirements set out in the on board documents

4.2. Prior to departure, perform the required tests, checks and verifications on the traction unit

- 4.3. **Take part in checking the operation of the brakes on the train**
- Check before departure, based on the relevant documents, if the available brake performance complies with what is required for the train and the route it is to travel over.
 - Contribute to the brake tests as required by relevant operation rules and verify the correct working of the brake system
- 4.4. **Drive the train respecting the appropriate safety regulations, driving rules and timetable**
- Start movement of the train only if all requirements provided — especially train data — in the relevant rules are met.
 - Observation of track side signals and in-cab devices, understanding them immediately and correctly and react accordingly while running the train.
 - Take into account the speed limit of the train in relation to the type of train, the characteristics of the line, the traction unit and any information the driver is provided with before departure.
- 4.5. **Act and report in accordance with the applicable rules in case of irregularities or defects either of lineside installations or rolling stock**
- 4.6. **Apply measures relating to operational incidents and accidents, particularly those relating to train protection and to fire or dangerous goods**
- Initiate all appropriate measures to protect passengers and other persons that could be endangered. Provide necessary information and take part in the evacuation of passengers as required
 - Inform the Infrastructure Manager as appropriate.
 - Communication with on-board staff (as required by the Railway Undertaking).
 - Apply the special rules related to the transport of dangerous goods.
- 4.7. **Determine the conditions to continue to run after incidents affecting the rolling stock**
- Decide dependent on the operational procedures and on the basis of personal examination or external advice, if the train is able to continue to run and what kind of conditions must be observed.
 - Communicate to the Infrastructure Manager as required by the operational rules
- 4.8. **Park the train and, once stationary, take all required measures to ensure the train remains stationary**
- 4.9. **Communicate with the Infrastructure Manager's staff on the ground**
- 4.10. **Report any unusual occurrences concerning the operation of the train, the conditions of the infrastructure etc.**
- If required this report must be made in writing, in the language chosen by the Railway Undertaking.
-

ANNEX I

Not used

—

ANNEX J

Minimum elements relevant to professional competence for the tasks associated with 'accompanying trains'**1. GENERAL REQUIREMENTS**

- This Annex, which must be read in conjunction with Subsections 4.6 and 4.7 of this TSI and the requirements of the SRT TSI, is a list of the elements that are deemed to be relevant to the task of accompanying a train on the high speed lines of the TEN.

It should be noted that whilst this document is as complete as it can be in terms of a generally applicable list, there will be additional items, of a local/national nature, that will also need to be considered.

- The expression 'professional competence', when taken within the context of this TSI, refers to those elements that are important to ensuring that operational staff are trained and able to understand and discharge the elements of the task.
- Rules and procedures apply to the task being performed and to the person carrying out the task. These tasks may be carried out by any authorised competent person irrespective of any name, job title or grade used in rules or procedures or by the individual company.
- Any authorised competent person must carry out all rules and procedures related to the task being performed.

2. PROFESSIONAL KNOWLEDGE

Any authorisation requires a successfully passed initial examination and provisions for ongoing assessment and training as described in Subsection 4.6.

2.1. General professional knowledge

- General principles of safety management within the railway system, relevant to the task, including interfaces with other subsystems
- General conditions relevant to the safety of passengers and/or cargo (including the carriage of dangerous goods) and persons on or about the railway track
- Conditions of health and safety at work
- General principles of security of the railway system
- Personal safety including when leaving the train on the running line
- First aid where staff is required to administer first aid as part of their duties

2.2. Knowledge of operational procedures and safety systems applied to the infrastructure to be used

- Operational procedures and safety rules
- Control command and signalling system
- Communications protocol and formalised messaging procedure including use of communication equipment

2.3. Knowledge of rolling stock

- Passenger vehicle interior equipment:
- Repairing minor defects within the passenger areas of rolling stock, as required by the Railway Undertaking

2.4. Knowledge of the route

- Operational arrangements (such as the method of train despatch) at individual locations (signalling, station equipment etc.)
- Stations at which passengers may alight or join
- Local operating and emergency arrangements specific to the line(s) of route

3. ABILITY TO PUT THE KNOWLEDGE INTO PRACTISE

- Checks before departure, including brake tests and correct closure of the doors.
 - Departure processes
 - Communication with passengers especially in relation to circumstances involving passenger safety.
 - Degraded operations
 - Assess the potential of a defect within the passenger areas and react according to rules and procedures
 - Protection and warning measures as required by the rules and regulations or in assistance to the driver
 - Train evacuation and passenger safety especially if they are required to be on or near the line.
 - Communicate with the Infrastructure Manager's staff when assisting the driver or during an evacuation incident.
 - Report any unusual occurrences concerning the operation of the train, the condition of the rolling stock and the safety of passengers. If required these reports must be made in writing, in the language chosen by the Railway Undertaking.
-

ANNEX K

Not used

ANNEX L

Minimum elements relevant to professional competence for the task of preparing trains

1. GENERAL REQUIREMENTS

- This Annex, which must be read in conjunction with Subsection 4.6, is a list of the elements that are deemed to be relevant to the task of preparing a train on the that will operate in the high speed lines of the TEN.

It should be noted that whilst this document is as complete as it can be in terms of a generally applicable list, there will be additional items, of a local/national nature, that will also need to be considered.

- The expression 'professional competence', when taken within the context of this TSI, refers to those elements that are important to ensuring that operational staff are trained and able to understand and discharge the elements of the task.
- Rules and procedures apply to the task being performed and to the person carrying out the task. These tasks may be carried out by any authorised competent person irrespective of any name, job title or grade used in rules or procedures or by the individual company.
- Any authorised competent person must carry out all rules and procedures related to the task being performed.

2. PROFESSIONAL KNOWLEDGE

Any authorisation requires a successfully passed initial examination and provisions for ongoing assessment and training as described in Subsection 4.6.

2.1. **General professional knowledge**

- General principles of safety management within the railway system, relevant to the task, including interfaces with other subsystems
- General conditions relevant to the safety of passengers and/or cargo including the carriage of dangerous goods and exceptional loads
- Conditions of health and safety at work
- General principles of security of the railway system
- Personal safety when on or in the vicinity of rail lines
- Communications protocol and formalised messaging procedure including use of communication equipment

2.2. **Knowledge of operational procedures and safety systems applied to the infrastructure to be used**

- Working of trains in normal, degraded and emergency conditions
- Operational procedures at individual locations (signalling, station/depot/yard equipment) and safety rules
- Local operating arrangements

2.3. Knowledge of train equipment

- Purpose and use of wagon and vehicle equipment
- Identification of and arranging for technical inspections.

3. ABILITY TO PUT THE KNOWLEDGE INTO PRACTISE

- Application of train composition rules, train braking rules, train loading rules etc. to ensure the train is in running order
- Understanding of marking and labels on vehicles
- Process for determining and making train data available
- Communication with train crew
- Communication with staff responsible for controlling the movement of trains
- Degraded operations especially as it affects the preparation of trains
- Protection and warning measures as required by the rules and regulations or local arrangements at the location in question
- Actions to be taken in respect to incidents involving the carriage of dangerous goods (where relevant)

ANNEX M

Not used

ANNEX N

Informative and not mandatory Implementation Guidelines

The table below is informative and lists clauses from Chapter 4 and identifies a likely trigger for each of them.

Chapter 4 section	Work required by IM/RU to comply with requirements	Typical Trigger
4.2.1.2.1 Rule Book	RU — Production/revision of a document or a computer medium containing necessary operational procedures for working over IM's network	Change to network operational instructions
4.2.1.2.2.1 Preparation of the Route Book	RU — Production/revision of a document or a computer medium containing a description of the lines over which they will operate	Change to network infrastructure (e.g. junction re-modelling, re-signalling) resulting in amended route information
4.2.1.2.2.2 Modified Elements	RU — Definition/revision of procedure(s) whereby a document or computer medium is provided to drivers to inform them of any [route] elements modified	Change to RU's operational safety management system, resulting in amended roles and responsibilities
4.2.1.2.2.3 Informing the driver in real time	IM — Definition/revision of procedure(s) for advising drivers in real time about all modifications to [route] safety arrangements	Change to IM's or RU's organisational structure, resulting in amended roles and responsibilities
4.2.1.2.3 Timetables	RU — Definition/revision of procedure(s) for providing drivers with timetable information, in paper or electronic format	Change to RU's operational safety management system, resulting in amended roles and responsibilities Implementation of new (electronic) traffic management system
4.2.1.2.4 Rolling Stock	RU — Production/revision of a document or a computer medium containing necessary operational procedures associated with working of rolling stock during degraded situations.	Change to RU's operational safety management system, resulting in amended roles and responsibilities Implementation of new/modified rolling stock
4.2.1.3 Documentation for RU staff other than drivers	RU — Production/revision of a document or a computer medium containing necessary operational procedures for staff other than drivers working on or over IM's network	Change to RU's operational safety management system, resulting in amended roles and responsibilities Change to network infrastructure resulting in amended route information or introduction of new/modified rolling stock
4.2.1.4 Documentation for IM staff authorising train movements	IM — Production/revision of a document or a computer medium containing network operational procedures, including communications protocol and the 'Book of Forms'	Change to network operational arrangements as a result of an identified improvement action (e.g. inquiry recommendation) Change to network infrastructure resulting in amended operational arrangements
4.2.1.5 Safety-related communication between RU and IM staff	IM/RU — Document/computer mediums referred to in 4.2.1.2.1, 4.2.1.3 & 4.2.1.4 to include operational communication methodology as specified in annex C of the TSI	In conjunction with 4.2.1.2.1, 4.2.1.3 & 4.2.1.4
4.2.2.1.2 Train Visibility (Front End)	RU — Definition/revision of procedure(s) for drivers and/or other operational staff to ensure correct front end illumination	Change to RU's operational safety management system, resulting in amended roles and responsibilities Implementation of new/modified rolling stock

Chapter 4 section	Work required by IM/RU to comply with requirements	Typical Trigger
4.2.2.4 Requirements for passenger vehicles	RU — Definition/revision of procedure(s) to ensure that passenger vehicles are in compliance with the requirements of this TSI	Implementation of new/modified passenger vehicles Change to network operational rules affecting passenger vehicles
4.2.2.5 Train composition	RU — Definition/revision of procedure(s) to ensure that the trains is in compliance with the allocated path	Change to RU's operational safety management system, resulting in amended roles and responsibilities Change to network operational rules affecting train composition New/altered infrastructure, signalling or implementation of new (electronic) traffic management system
4.2.2.6.1 Minimum requirements of the braking system	RU — Definition/revision of procedure(s) for operational staff to ensure that vehicles in train comply with braking requirements	Change to RU's operational safety management system, resulting in amended roles and responsibilities
4.2.2.6.2 Brake performance	IM — Definition/revision of procedure(s) for supplying RU's with braking performance information RU — Production/revision of a document or a computer medium containing braking rules for its staff to follow, taking into account geography of route(s), allocated pathway and development of ERTMS/ETCS	Change to IM's operational safety management system, resulting in amended roles and responsibilities Change to RU's operational safety management system, resulting in amended roles and responsibilities Change to network operational rules affecting braking rules New/altered infrastructure, signalling or implementation of new (electronic) traffic management system Implementation of new/modified rolling stock
4.2.2.7.1 Ensuring that the train is in running order (General Requirements)	RU — Definition/revision of procedure(s) for operational staff to ensure that vehicles are in running order, including advising IM of changes that may affect running performance and running in degraded mode.	Change to RU's operational safety management system, resulting in amended roles and responsibilities
4.2.2.7.2 Data required	RU — Definition/revision of procedure(s) to ensure that train running information is made available to IM prior to departure	Change to RU's operational safety management system, resulting in amended roles and responsibilities Implementation of new (electronic) traffic management system
4.2.3.2 Identification of Trains	IM — Definition/revision of procedure(s) for assigning unique and unambiguous train identification numbers	Change to IM's or RU's train planning system, resulting in amended roles and responsibilities Implementation of new (electronic) traffic management system
4.2.3.3.1 Checks & tests before departure	RU — Definition/revision of checks and tests that must be undertaken before departure	Change to RU's operational safety management system, resulting in amended roles and responsibilities
4.2.3.3.2 Informing IM of train's operational status	RU- Definition/revision of procedure(s) for reporting rolling stock-related factors that could affect train running	Change to IM's or RU's operational safety management system, resulting in amended roles and responsibilities Implementation of new (electronic) traffic management system

Chapter 4 section	Work required by IM/RU to comply with requirements	Typical Trigger
4.2.3.4.1 Traffic Management General Requirements	IM — Definition/revision of procedure(s) for control and supervision of traffic operation, including interface with any additional processes required by RU's	Change to IM's or RU's operational safety management system, resulting in amended roles and responsibilities
		Implementation of new (electronic) traffic management system
4.2.3.4.2 Train Reporting	IM — Definition/revision of procedure(s) for train position reporting, including real time recording of arrivals/departures and predicted hand over times to other IM's.	Change to IM's traffic management system, resulting in amended roles and responsibilities
		Implementation of new (electronic) traffic management system
4.2.3.4.3 Dangerous Goods	RU — Definition/revision of procedure(s) for supervising the transport of dangerous goods, including provision of information required by IM.	Change to IM's or RU's operational safety management system, resulting in amended roles and responsibilities
4.2.3.4.4 Operational Quality	IM/RU — Documented procedures, describing internal processes for monitoring and review of operational performance and identifying improvement actions to improve network efficiency.	Change to IM's or RU's traffic management system, resulting in amended roles and responsibilities
		Implementation of new (electronic) traffic management system, including performance monitoring
4.2.3.5.1 Recording of Supervision data outside the train	IM — Definition/revision of procedure(s) for recording the required data, and storage and access arrangements	Change to IM's operational safety management system, resulting in amended roles and responsibilities
		Change to network infrastructure resulting in new/amended monitoring equipment
4.2.3.5.2 Recording of Supervision data on-board the train	RU — Definition/revision of procedure(s) for recording the required data, and storage and access arrangements	Change to RU's operational safety management system, resulting in amended roles and responsibilities
		Implementation of new/modified rolling stock (locomotives, multiple units)
4.2.3.6.1 Degraded Operation — Advice to other users	IM/RU — Definition/revision of procedure(s) for informing each other of situations likely to impede safety, performance or availability of network	Change to IM's or RU's traffic management system, resulting in amended roles and responsibilities
		Implementation of new (electronic) traffic management system
4.2.3.6.2 Advice to train drivers	IM — Definition/revision of instructions to drivers to deal with degraded situation	Change to IM's or RU's traffic management system, resulting in amended roles and responsibilities
4.2.3.6.3 Contingency arrangements	IM — Definition/revision of procedure(s) for dealing with degraded operation, including rolling stock and infrastructure failures (contingency arrangements)	Change to IM's or RU's traffic management system, resulting in amended roles and responsibilities
		Change to network infrastructure or introduction of new/modified rolling stock
4.2.3.7 Managing an Emergency Situation	IM/RU — Definition/revision of procedure(s) detailing contingency measures for dealing with emergency situations	Change to RU's operational safety management system, resulting in amended roles and responsibilities
4.2.3.8 Aid to traincrew for rolling stock incident/malfunction	RU — Definition/revision of procedure(s) for traincrew to deal with technical or other failure of rolling stock	Change to RU's traffic management system, resulting in amended roles and responsibilities
		Introduction of new/modified rolling stock

Chapter 4 section	Work required by IM/RU to comply with requirements	Typical Trigger
4.4 Operating Rules	IM/RU — Definition of rules and procedures to be used with ETCS and GSM-R and/or HABD	Introduction of ETCS signalling system and/or GSM-R radio system and/or HABD
4.6.1.1 Professional Knowledge	IM/RU — Definition of Process for assessing professional knowledge	Change to IM/RU's operational safety management system, resulting in amended roles and responsibilities
4.6.1.2 Ability to put this knowledge into practice	IM/RU — Definition/revision of competence management system to ensure staff's ability to put knowledge into practice	Change to IM/RU's operational safety management system, resulting in amended roles and responsibilities
4.6.2.2 Linguistic level of knowledge	IM/RU — Definition/revision of procedure(s) for assessing linguistic ability	Change to IM/RU's operational safety management system, resulting in amended roles and responsibilities
4.6.3.1 Assessment of Staff — Basic Elements	IM/RU — Definition/revision of assessment process(es) staff including: <ul style="list-style-type: none"> — Experience/competences — Language — Competence retention 	Change to IM/RU's operational safety management system, resulting in amended roles and responsibilities
4.6.3.2 Analysis of Training Needs	IM/RU — Definition/revision of the process for undertaking and updating analysis of training needs for staff	Change to IM/RU's operational safety management system, resulting in amended roles and responsibilities
4.6.3.2.3 Specific elements for train-crew	RU — Definition/revision of the process for train crew acquisition and retention of: <ul style="list-style-type: none"> — Route knowledge — Rolling stock knowledge 	Change to RU's operational safety management system, resulting in amended roles and responsibilities
4.7.1 Health and Safety Conditions Introduction	IM/RU — Definition/revision of procedure(s) for ensuring medical fitness of staff, including controls of affects of drugs and alcohol on operational performance	Change to RU's operational safety management system, resulting in amended roles and responsibilities
4.7.2-4.7.4 Criteria for approval of occupational doctors, medical organisations, psychologists & examinations	IM/RU — Determination/revision of criteria for: <ul style="list-style-type: none"> — Approval of occupational doctors and medical organisations — Approval of psychologists — Medical and psychological examination 	Change to RU's operational safety management system, resulting in amended roles and responsibilities Change to national rules and practices for approval of medical practitioners and recognition of organisations
4.7.5 Medical requirements	IM/RU — Determination/revision of medical requirements, including <ul style="list-style-type: none"> — General health — Vision — Hearing — Pregnancy 	Change to RU's operational safety management system, resulting in amended roles and responsibilities
4.7.6 Specific Requirements regarding the task of driving a train	IM/RU — Determination/revision of specific driver medical requirements, including: <ul style="list-style-type: none"> — ECG Monitoring (40+ year old) — Vision — Hearing/speaking requirements — Anthropometrics 	Change to RU's operational safety management system, resulting in amended roles and responsibilities

ANNEX O

Not used

—

ANNEX P

Vehicle identification**General remarks:**

1. This annex describes the number and linked marking applied in a visible manner on the vehicle to identify it uniquely in operation. It does not describe other numbers or markings eventually engraved or fixed in a permanent manner on the chassis or the main components of the vehicle during its construction.
2. The conformity of the number and linked marking with the indications described in this annex is not mandatory for:
 - vehicles that are only used on networks to which this TSI does not apply;
 - heritage vehicles, in a historical guise;
 - vehicles that are not normally used or transported on the networks to which this TSI applies.

Nevertheless, these vehicles must receive a temporary number permitting their operation.

3. This annex is subject to changes due to the future evolution of RIC and future development and implementation of the TAP TSI.

Standard number and linked abbreviations

Each railway vehicle receives a number consisting of 12 figures (called standard number) with the following structure:

Types of rolling stock	Type of vehicle and indication of the interoperability [2 figures]	Country in which the vehicle is registered [2 figures]	Technical characteristics [4 figures]	Serial number [3 figures]	Self-checking digit [1 figure]
Wagons	00 to 09 10 to 19 20 to 29 30 to 39 40 to 49 80 to 89 <i>[details in annex P.6]</i>	01 to 99 <i>[details in annex P.4]</i>	0000 to 9999 <i>[details in annex P.9]</i>	001 to 999	0 to 9 <i>[details in annex P.3]</i>
Hauled passenger vehicles	50 to 59 60 to 69 70 to 79 <i>[details in annex P.7]</i>		0000 to 9999 <i>[details in annex P.10]</i>	001 to 999	
Tractive rolling stock	90 to 99 <i>[details in annex P.8]</i>		0000001 to 8999999 <i>[the meaning of these figures is defined by the Member States, eventually by bilateral or multilateral agreement]</i>		
Special vehicles			9000 to 9999 <i>[details in annex P.11]</i>	001 to 999	

In a given country, the 7 digits of technical characteristics and serial number are sufficient to identify uniquely a vehicle inside each group of wagons, hauled passenger vehicles, tractive rolling stock ⁽¹⁾ and special vehicles ⁽²⁾.

Alphabetical markings complete the number:

- (a) markings linked to the interoperability ability (*details in annex P.5*);
- (b) abbreviation of the country in which the vehicle is registered (*details in annex P.4*);
- (c) keeper's ⁽³⁾ abbreviation (*details in annex P.1*);
- (d) abbreviation of the technical characteristics (*details in annex P.13 for the hauled passenger vehicles, annex P.12 for the wagons, annex P.14 for the special vehicles*).

Technical characteristics, codes and abbreviations are managed by one or more bodies (hereafter designed as 'central body') to be proposed by ERA (European Railway Agency) as a result of activity N° 15 of its work programme 2005.

Allocation of number

The rules for the management of the numbers will be proposed by the ERA as part of the activity N° 15 of its work programme 2005.

⁽¹⁾ For tractive rolling stock, the number has to be unique in a given country with 6 digits.

⁽²⁾ For special vehicles, the number has to be unique in a given country with the first digit and the 5 last digits of the technical characteristics and serial number.

⁽³⁾ A vehicle keeper is the person, who being the owner or having the right to dispose of it, exploits a vehicle economically in a permanent manner as a means of transport and is registered as such in the Rolling Stock Register.

ANNEX P.1

Keeper's abbreviation marking**Definition of the Vehicle Keeper Marking (VKM)**

A Vehicle Keeper Marking (VKM) is an alphanumeric code, consisting of 2 to 5 letters ⁽¹⁾. A VKM is inscribed on each rail vehicle, near the vehicle number. The VKM denominates the Vehicle Keeper as registered in the Rolling Stock Register.

A VKM is unique in all countries covered by this TSI and all countries that enter into an agreement that involves the application of the system of vehicle numbering and vehicle keeper marking as described in this TSI.

Format of the Vehicle Keeper Marking

The VKM is representation of the full name or abbreviation of the vehicle keeper, if possible in a recognisable manner. All 26 letters of the Latin alphabet may be used. The letters in the VKM are written in capitals. Letters that do not stand for first letters of words in the keeper's name may be written in lower case. For checking uniqueness, the written name will be ignored.

Letters may contain diacritical signs ⁽²⁾. Diacritical signs used by these letters are ignored for checking uniqueness.

For vehicles of keepers that reside in a country that does not use the Latin alphabet, a translation of the VKM in its own alphabet may be applied behind the VKM separated from it by a slash-sign ('/'). This translated VKM is disregarded for data-processing purposes.

Exemptions for using a Vehicle Keeper Marking

Member States may decide to apply the following exemptions.

A VKM is not required for the vehicles whose numbering system does not follow the present annex (*cf.* general remark, point 2). Nevertheless, adequate information about the identity of the vehicle keeper has to be provided to the organisations involved in their operation over networks to which this TSI applies.

When the full name and address information is inscribed on the vehicle, a VKM is not required for:

- vehicles of keepers with such a limited vehicle fleet that this does not warrant the use of a VKM;
- specialised vehicles for infrastructure maintenance.

A VKM is not required for locomotives, multiple units and passenger vehicles used in national traffic only, when:

- they carry their keeper's logo and that logo contains the same and well recognisable letters as the VKM;
- they carry a well recognisable logo that has been accepted by the competent national authority as an adequate equivalent for the VKM.

When a company logo is applied in addition to the application of a VKM, only the VKM is valid and the logo is disregarded.

Provisions about allocation of Vehicle Keeper Markings

A vehicle keeper can be issued more than one VKM, in case:

- the vehicle keeper has a formal name in more than one language;
- a vehicle keeper has good cause to distinguish between separate vehicle fleets within his organisation.

⁽¹⁾ For NMBS/SNCB, the use of an encircled single letter B can be continued.

⁽²⁾ Diacritical marks are 'accent-signs', such as in À, Ç, Ö, Ć, Ž, Å etc. Special letters such as Ø and Æ will be represented by a single letter; in tests for uniqueness Ø is treated as O and Æ as A.

A single VKM can be issued for a group of companies:

- that belong to single corporate structure that has appointed and mandated one organisation within this structure to handle all issues on behalf of all others;
- that has mandated a separate, single legal entity for handling all issues on their behalf, in which event the legal entity is the keeper.

Register of Vehicle Keeper Markings and procedure for allocation

The register of VKM is public and updated on a real time basis.

An application for a VKM is filed with the applicant's competent national authority and forwarded to the central body. A VKM can be used only after publication by the central body.

The holder of a VKM must inform the competent national authority when he ends the use of a VKM, and the competent national authority will forward the information to the central body. A VKM will then be revoked once the keeper has proved that the marking has been changed on all vehicles concerned. It will not be reissued for 10 years, unless it is reissued to the original holder or at his request to another holder.

A VKM can be transferred to another holder, which is the legal successor to the original holder. A VKM stays valid when the holder changes his name to a name that does not bear resemblance to the VKM.

The first list of VKM will be drafted using existing railway company abbreviations.

The VKM will be applied to all new build wagons after entry into force of the relevant TSIs. Existing wagons will have until end 2014 to comply with VKM marking.

ANNEX P.2

Inscription of the number and linked alphabetical marking on the bodywork**General arrangements for external markings**

The capital letters and figures making up the marking inscriptions shall be at least 80 mm in height, in a sans serif font type of correspondence quality. A smaller height may only be used where there is no option but to place the marking on the sole bars.

The marking is put not higher than 2 metres above rail level.

Wagons

The marking shall be inscribed on the wagon bodywork in the following manner:

23	TEN	31	TEN	33	TEN	43		(In this case without VKM, full name and address information is inscribed on the vehicle)
80	D-RFC	80	D-DB	84	NL-ACTS	87	F	
7369 553-4		0691 235-2		4796 100-8		4273 361-3		
Zcs		Tanoos		Slpss		Laeks		

For wagons whose bodywork does not offer a large enough area for this type of arrangement, particularly in the case of flat wagons, the marking shall be arranged as follows:

01	87	3320 644-7
TEN	F-SNCF	Ks

When one or more index letters of national significance are inscribed on a wagon, this national marking must be shown after the international letter marking and separated from it by a hyphen.

Coaches and hauled passenger stock

The number shall be applied to each sidewall of the vehicle in the following manner:

F-SNCF 61 87 $\frac{20-72021}{B^{10}tu}$ - 7

The marking of the country in which the vehicle is registered and of the technical characteristics are printed directly in front of, behind or under the twelve digits of the vehicle number.

In case of coaches with driver's cabin, the number is also written inside the cabin.

Locomotives, power cars and special vehicles

The standard 12-digit number must be marked on each sidewall of the tractive stock used in international service in the following manner:

91 88 0001323-0

The standard 12-digit number is also written inside each cabin of the tractive rolling stock.

The keeper can add, in letters of larger size than the standard number, an own number marking (consisting generally of digits of the serial number supplemented by alphabetical coding) useful in operations. The place where the own number is marked is left to the choice of the keeper.

Examples SP 42037 ES 64 F4-099 88-1323 473011
 92 51 0042037-9 94 80 0189 999-6 91 88 0001323-0 92 87 473011-0 94 79 2 642 185-5

These rules may be altered in bilateral agreements for vehicles existing when the TSI comes into force and assigned to a specific service and where there is no risk of confusion between different stocks operating on the rail networks concerned. The exemption is valid for a period decided upon by the competent national authorities.

The national authority can prescribe that the alphabetic country code and the VKM be recorded additional to the 12 digit vehicle number.

ANNEX P.3

Rules for the determination of the check-digit (digit 12)

The check-digit is determined in the following manner:

- the digits in the even positions of the basic number (counting from the right) are taken at their own decimal value;
- the digits in the odd positions of the basic number (counting from the right) are multiplied by 2;
- the sum formed by the digits in even position and by all the digits which constitute the partial products obtained from the odd positions is then established;
- the units digit of this sum is retained;
- the complement required to bring the units digit to 10 forms the check-digit; should this units digit be nought, then the check-digit will also be nought.

Examples:

1 —	Let the basic number be	3	3	8	4	4	7	9	6	1	0	0
	Multiplication factor	2	1	2	1	2	1	2	1	2	1	2
		6	3	16	4	8	7	18	6	2	0	0

Sum: $6 + 3 + 1 + 6 + 4 + 8 + 7 + 1 + 8 + 6 + 2 + 0 + 0 = 52$

The units digit of this sum is 2.

The check-digit number will therefore be 8 and the basic number thus becomes the registration number 33 84 4796 100-8.

2 —	Let the basic number be	3	1	5	1	3	3	2	0	1	9	8
	Multiplication factor	2	1	2	1	2	1	2	1	2	1	2
		6	1	10	1	6	3	4	0	2	9	16

Sum: $6 + 1 + 1 + 0 + 1 + 6 + 3 + 4 + 0 + 2 + 9 + 1 + 6 = 40$

The units digit of this sum is 0.

The check-digit number will therefore be 0 and the basic number thus becomes the registration number 31 51 3320 198-0.

ANNEX P.4

Coding of the countries in which the vehicles are registered (digits 3-4 and abbreviation)*'Information relating to third countries given for information purposes only.'*

Countries	Alphabetical country code ⁽³⁾	Numerical country code	Companies concerned by the square brackets in annexes P.6 and P.7 ⁽⁴⁾
Albania	AL	41	HSh
Algeria	DZ	92	SNTF
Armenia	AM ⁽¹⁾	58	ARM
Austria	A	81	ÖBB
Azerbaijan	AZ	57	AZ
Belarus	BY	21	BC
Belgium	B	88	SNCB/NMBS
Bosnia-Herzegovina	BIH	44	ŽRS
		50	ŽFBH
Bulgaria	BG	52	BDZ, SRIC
China	RC	33	KZD
Croatia	HR	78	HŽ
Cuba	CU ⁽¹⁾	40	FC
Cyprus	CY		
Czech Republic	CZ	54	ČD
Denmark	DK	86	DSB, BS
Egypt	ET	90	ENR
Estonia	EST	26	EVR
Finland	FIN	10	VR, RHK
France	F	87	SNCF, RFF
Georgia	GE	28	GR
Germany	D	80	DB, AAE ⁽²⁾
Greece	GR	73	CH
Hungary	H	55	MÁV, GySEV/ROeEE ⁽²⁾
Iran	IR	96	RAI
Iraq	IRQ ⁽¹⁾	99	IRR
Ireland	IRL	60	CIE
Israel	IL	95	IR
Italy	I	83	FS, FNME ⁽²⁾
Japan	J	42	EJRC
Kazakhstan	KZ	27	KZH
Kyrgyzstan	KS	59	KRG
Latvia	LV	25	LDZ
Lebanon	RL	98	CEL
Liechtenstein	LIE ⁽¹⁾		
Lithuania	LT	24	LG
Luxembourg	L	82	CFL
Macedonia (Former Yugoslav Republic of)	MK	65	CFARYM (MŽ)
Malta	M		

Countries	Alphabetical country code ⁽³⁾	Numerical country code	Companies concerned by the square brackets in annexes P.6 and P.7 ⁽⁴⁾
Moldova	MD ⁽¹⁾	23	CFM
Monaco	MC		
Mongolia	MGL	31	MTZ
Morocco	MA	93	ONCFM
Netherlands	NL	84	NS
North Korea	PRK ⁽¹⁾	30	ZC
Norway	N	76	NSB, JBV
Poland	PL	51	PKP
Portugal	P	94	CP, REFER
Romania	RO	53	CFR
Russia	RUS	20	RZD
Serbia-Montenegro	SCG	72	JŽ
Slovakia	SK	56	ŽSSK, ŽSR
Slovenia	SLO	79	SŽ
South Korea	ROK	61	KNR
Spain	E	71	RENFE
Sweden	S	74	GC, BV
Switzerland	CH	85	SBB/CFF/FFS, BLS ⁽²⁾
Syria	SYR	97	CFS
Tajikistan	TJ	66	TZD
Tunisia	TN	91	SNCFT
Turkey	TR	75	TCDD
Turkmenistan	TM	67	TRK
Ukraine	UA	22	UZ
United Kingdom	GB	70	BR
Uzbekistan	UZ	29	UTI
Vietnam	VN ⁽¹⁾	32	DSVN

⁽¹⁾ Codes to be confirmed.

⁽²⁾ Until the evolutions indicated in point 3 of the general remarks come into force, these companies can use the codes 43 (GySEV/ROeEE), 63 (BLS), 64 (FNME), 68 (AAE). The period of updating will then be defined together with the concerned Member States.

⁽³⁾ According to the alphabetical coding system described in Appendix 4 to the 1949 convention and Article 45(4) of the 1968 convention on road traffic.

⁽⁴⁾ Companies who, at the time of coming into force, were members of UIC or OSJD and used the described country code as company code.

ANNEX P.5

Alphabetical marking of the interoperability capability

- TEN: Vehicle, which complies with Rolling Stock TSI
RIV: Wagon, which complies with the RIV regulations at the date of their abolishment
PPW: Wagon, which complies with PPW agreement (inside OJSD States)
RIC: Coach which complies/complied with RIC regulations

The alphabetical marking of the interoperability capability concerning special vehicles is described in annex P.14.

ANNEX P.6

Interoperability codes used for wagons (digits 1-2)

		2 nd digit		0	1	2	3	4	5	6	7	8	9	2 nd digit	
1 st digit				fixed or variable	fixed	variable	fixed	variable	fixed	variable	fixed	variable	fixed or variable	Gauge	1 st digit
TSI ^(a) and/or COTIF ^(b) and/or PPW	0	with axles	Spare	Wagons used by industry	TSI and/or COTIF wagons ^(b) <i>[of which keeper is a railway undertaking listed in annex P.4]</i>		Not to be used pending further decision						PPW wagons (variable gauge)	with axles	0
	1	with bogies												with bogies	1
	2	with axles	Spare		TSI and/or COTIF wag- on ^(b) <i>[of which keeper is a railway undertaking listed in annex P.4]</i>		TSI and/or COTIF wagons ^(b) PPW wagons			Others TSI and/or COTIF wagons ^(b) PPW wagons			PPW wagons (fixed gauge)	with axles	2
	3	with bogies												with bogies	3
Non TSI and non COTIF ^(b) and non PPW	4	with axles ^(c)	Service wag- ons		Others wagons <i>[of which keeper is a railway undertaking listed in annex P.4]</i>		Others wagons			Others wagons			Wagons with special numbering for technical characteristics	with axles ^(d)	4
	8	with bogies ^(c)												with bogies ^(d)	8
		Traffic		Domestic traffic or international traffic by special agreement	Interna- tional traffic by special agreement	Domestic traffic	Interna- tional traffic by special agreement	Domestic traffic	Interna- tional traffic by special agreement	Domestic traffic	Interna- tional traffic by special agreement	Domestic traffic	Domestic traffic or international traffic by special agreement	Traffic	
1 st digit		2 nd digit		0	1	2	3	4	5	6	7	8	9	1 st digit	
				0	1	2	3	4	5	6	7	8	9	2 nd digit	

^(a) Compliance at least with Rolling Stock TSI.

^(b) Including vehicles, which according to existing regulations carry these digits at the time of coming into force of these new regulations.

^(c) Fixed or variable gauge.

^(d) Excepted for wagons in category I (temperature-controlled wagons).

International traffic ability codes used for hauled passenger vehicles (digits 1-2)

Warning:

The conditions between square brackets are transitional and will be deleted with the evolutions of RIC (see general remarks, point 3).

1 st digit	2 nd digit	Domestic traffic	TSI ^(a) and/or RIC/COTIF ^(b) and/or PPW				Domestic traffic or international traffic by special agreement	TSI ^(a) and/or RIC/COTIF ^(b)	PPW		
		0	1	2	3	4	5	6	7	8	9
5	Vehicles for domestic traffic <i>[of which keeper is a RIC railways undertaking listed in annex P.4]</i>	Fixed-gauge non air-conditioned vehicles (including car-carrying wagons) <i>[of which keeper is a RIC railways undertaking listed in annex P.4]</i>	Gauge-adjustable (1435/1520) non air-conditioned vehicles <i>[of which keeper is a RIC railways undertaking listed in annex P.4]</i>	Reserved	Gauge-adjustable (1435/1672) non air-conditioned vehicles <i>[of which keeper is a RIC railways undertaking listed in annex P.4]</i>	Vehicles with special numbering for technical characteristics	Fixed-gauge vehicles	Fixed-gauge vehicles	Gauge-adjustable (1435/1520) vehicles with change of bogies	Gauge-adjustable (1435/1520) vehicles with gauge-adjustable axles	
6	Service vehicles not run in revenue-earning service	Fixed-gauge air-conditioned vehicles <i>[of which keeper is a RIC railways undertaking listed in annex P.4]</i>	Gauge-adjustable (1435/1520) air-conditioned vehicles <i>[of which keeper is a RIC railways undertaking listed in annex P.4]</i>	Service vehicles not run in revenue-earning service <i>[of which keeper is a RIC railways undertaking listed in annex P.4]</i>	Gauge-adjustable (1435/1672) air-conditioned vehicles <i>[of which keeper is a RIC railways undertaking listed in annex P.4]</i>	Car-carrying wagons	Gauge-adjustable vehicles				
7	Air-conditioned and pressure-tight vehicles <i>[of which keeper is a RIC railways undertaking listed in annex P.4]</i>	Reserved	Reserved	Pressure-tight fixed-gauge air-conditioned vehicles <i>[of which keeper is a RIC railways undertaking listed in annex P.4]</i>	Reserved	Other vehicles	Reserved	Reserved	Reserved	Reserved	

^(a) Compliance at least with future TSI on hauled passenger vehicles.

^(b) Compliance with RIC or COTIF according to the regulation in force.

ANNEX P.8

Types of tractive stock (digits 1-2)

The first digit is '9'.

The second digit is defined by each Member State. It can for example fit with the self-checking digit if this digit is also calculated with the serial number.

If the second digit describes the type of tractive stock, following coding is mandatory:

Code	General vehicle type
0	Miscellaneous
1	Electric locomotive
2	Diesel locomotive
3	Electric multiple-unit set (high speed) [power car or trailer]
4	Electric multiple-unit set (except high speed) [power car or trailer]
5	Diesel multiple-unit set [power car or trailer]
6	Specialised trailer
7	Electric shunting engine
8	Diesel shunting engine
9	Maintenance vehicle

ANNEX P.9

Standard numerical marking of wagons (digits 5 to 7)

This annex indicates in tables the numerical marking in 4 figures associated to the main technical characteristics of the wagon.

This Annex is distributed on a separate medium (electronic file).

Codes for the technical characteristics of the hauled passenger stock (digits 5-6)

	6 th digit 5 th digit	0	1	2	3	4
Reserved	0	Reserved	Reserved	Reserved	Reserved	Reserved
Vehicles with 1 st class seats	1	10 side-corridor compartments or equivalent open-saloon space with centre aisle	≥ 11 side-corridor compartments or equivalent open-saloon space with centre aisle	Reserved	Reserved	Two or three axles
Vehicles with 2 nd class seats	2	10 side-corridor compartments or equivalent open-saloon space with centre aisle	11 side-corridor compartments or equivalent open-saloon space with centre aisle	≥ 12 side-corridor compartments or equivalent open-saloon space with centre aisle	Three axles	Two axles
Vehicles with 1 st or 1 st /2 nd class seats	3	10 side-corridor compartments or equivalent open-saloon space with centre aisle	11 side-corridor compartments or equivalent open-saloon space with centre aisle	≥ 12 side-corridor compartments or equivalent open-saloon space with centre aisle	Reserved	Two or three axles
1 st or 1 st /2 nd class couchette cars	4	10 1 st /2 nd class compartments	Reserved	Reserved	Reserved	≤ 9 1 st /2 nd class compartments
2 nd class couchette cars	5	10 compartments	11 compartments	≥ 12 compartments	Reserved	Reserved
Reserved	6	Reserved	Reserved	Reserved	Reserved	Reserved
Sleeping cars	7	10 compartments	11 compartments	12 compartments	Reserved	Reserved
Vehicles of special design and vans	8	Driving trailer with seats, all classes, with or without luggage compartment, with driving cab for reversible working	Vehicles with 1 st or 1 st /2 nd class seats with luggage or mail compartment	Vehicles with 2 nd class seats with luggage or mail compartment	Reserved	Vehicles with seats, all classes with specially-fitted areas, e.g. children's play area
	9	Mail vans	Luggage vans with mail compartment	Luggage vans	Luggage vans and two or three-axle 2 nd class vehicles with seats, with luggage or mail compartment	Side-corridor luggage vans, with or without compartment under customs seal

Note: Fractions of a compartment are not considered. The equivalent accommodation in open saloon cars with centre aisle is obtained by dividing the number of available seats by 6, 8 or 10 depending on the construction of the vehicle.

Codes for the technical characteristics of the hauled passenger stock (digits 5-6)

	6 th digit 5 th digit	5	6	7	8	9
Reserved	0	Reserved	Reserved	Reserved	Reserved	Reserved
Vehicles with 1 st class seats	1	Reserved	Double-deck coaches	≥ 7 side-corridor compartments or equivalent open-saloon space with centre aisle	8 side-corridor compartments or equivalent open-saloon space with centre aisle	9 side-corridor compartments or equivalent open-saloon space with centre aisle
Vehicles with 2 nd class seats	2	Only for OSJD, double-deck coaches	Double-deck coaches	Reserved	≥ 8 side-corridor compartments or equivalent open-saloon space with centre aisle	9 side-corridor compartments or equivalent open-saloon space with centre aisle
Vehicles with 1 st or 1 st /2 nd class seats	3	Reserved	Double-deck coaches	Reserved	≥ 8 side-corridor compartments or equivalent open-saloon space with centre aisle	9 side-corridor compartments or equivalent open-saloon space with centre aisle
1 st or 1 st /2 nd class couchette cars	4	Reserved	Reserved	Reserved	Reserved	≤ 9 1 st class compartments
2 nd class couchette cars	5	Reserved	Reserved	Reserved	Reserved	≤ 9 compartments
Reserved	6	Reserved	Reserved	Reserved	Reserved	Reserved
Sleeping cars	7	> 12 compartments	Reserved	Reserved	Reserved	Reserved
Vehicles of special design and vans	8	Coaches with seats and couchette cars, all classes, with bar or buffet area	Double-deck driving coach with seats, all classes, with or without luggage compartment, with driving cab for reversible working	Dining cars or coaches with bar or buffet area, with luggage compartment	Dining cars	Other special coaches (conference, disco, bar, cinema, video, ambulance coaches)
	9	Two or three-axle luggage vans with mail compartment	Reserved	Two or three-axle car-carrying wagons	Car-carrying wagons	Service vehicles

Note: Fractions of a compartment are not considered. The equivalent accommodation in open saloon cars with centre aisle is obtained by dividing the number of available seats by 6, 8 or 10 depending on the construction of the vehicle.

Codes for the general characteristics of hauled passenger stock (digits 7-8)

Energy supply	8 th digit	0	1	2	3	4	5	6	7	8	9
Maximum speed < 120 km/h	7 th digit 0	All voltages (*)	Reserved	3 000 V~ + 3 000 V =	1 000 V~ (*)	Reserved	1 500 V~	Other voltages than 1 000 V, 1 500 V, 3 000 V	1 500 V~ + 1 500 V =	3 000 V =	Reserved
	1	All voltages (*) + Steam (1)	1 000 V~ + Steam (1)	1 000 V~ + Steam (1)	1 000 V~ + Steam (1)	1 000 V~ + Steam (1)	1 000 V~ + Steam (1)	Reserved	1 500 V~ + 1 500 V = + Steam (1)	3 000 V = + Steam (1)	3 000 V = + Steam (1)
	2	Steam (1)	Steam (1)	3 000 V~ + 3 000 V = + Steam (1)	Steam (1)	3 000 V~ + 3 000 V = + Steam (1)	Steam (1)	3 000 V~ + 3 000 V = 1 500 V~ + Steam (1)	1 500 V~ + Steam (1)	1 500 V~ + Steam (1)	A (1)
121 to 140 km/h	3	All voltages	Reserved	1 000 V~ + 3 000 V =	1 000 V~ (*) (1)	1 000 V~ (*) (1)	1 000 V~	1 000 V~ + 1 500 V~ + 1 500 V =	1 500 V~ + 1 500 V =	3 000 V =	3 000 V =
	4	All voltages (*) + Steam (1)	All voltages + Steam (1)	All voltages + Steam (1)	1 000 V~ (*) (1) + Steam (1)	1 500 V~ + 1 500 V =	1 000 V~ + Steam (1)	3 000 V~ + 3 000 V =	1 500 V~ + 1 500 V = + Steam (1)	3 000 V = + Steam (1)	Reserved
	5	All voltages (*) + Steam (1)	All voltages + Steam (1)	All voltages + Steam (1)	1 000 V~ + Steam (1)	Reserved	1 500 V~ + Steam (1)	Other voltages than 1 000 V, 1 500 V, 3 000 V	1 500 V~ + 1 500 V = + Steam (1)	Reserved	Reserved
	6	Steam (1)	Reserved	3 000 V~ + 3 000 V =	Reserved	3 000 V~ + 3 000 V =	Reserved	Steam (1)	Reserved	Reserved	A (1)

Energy supply	8 th digit	0	1	2	3	4	5	6	7	8	9
Maximum speed	7 th digit										
141 to 160 km/h	7	All voltages (*)	All voltages	1 500 V~ ⁽¹⁾ + 3 000 V = ⁽¹⁾ All volt- ages ⁽²⁾	1 000 V~ (*)	1 500 V~ + 1 500 V =	1 000 V~	1 500 V~	1 500 V~ + 1 500 V =	3 000 V =	3 000 V =
	8	All voltages (*) + Steam ⁽¹⁾	All voltages + Steam ⁽¹⁾	3 000 V~ + 3 000 V =	Reserved	All voltages (*) + Steam ⁽¹⁾	1 000 V~ + Steam ⁽¹⁾	3 000 V~ + 3 000 V =	Other volt- ages than 1 000 V, 1 500 V, 3 000 V	All volt- ages (*) + Steam ⁽¹⁾	A ⁽¹⁾ G ⁽²⁾
> 160 km/h	9	All volt- ages (*) ⁽²⁾	All voltages	All voltages + Steam ⁽¹⁾	1 000 V~ + 1 500 V~	1 000 V~	1 000 V~	Reserved	1 500 V~ + 1 500 V =	3 000 V =	A ⁽¹⁾ G ⁽²⁾

⁽¹⁾ Only for domestic traffic vehicles

⁽²⁾ Only for vehicles able to international traffic

All voltages Single phase alternating current 1 000 V 51 to 15 Hz, single phase alternating current 1 500 V 50 Hz, direct current 1 500 V, direct current 3 000 V. Can also include single phase alternating current 3 000 V 50 Hz

(*) For certain vehicles with 1 000 V single phase alternating current, only one frequency, either 16 2/3 or 50 Hz, is permitted

A Autonomous heating, without train bus electricity supply line

G Vehicles with train bus electricity supply line for all voltages, but requiring a generator van to supply air-conditioning

Steam Steam heating only. If voltages are written, the code is also available for vehicles without steam heating.

ANNEX P.11

Codes for the technical characteristics of the special vehicles (digit 6 to 8)

Authorised speed for special vehicles (digit 6)

Classification			Self-propelled travelling speed		
			≥ 100 km/h	< 100 km/h	0 km/h
Can be put into a train	V ≥ 100 km/h	Self-propelled	1	2	
		Non self-propelled			3
	V < 100 km/h and/or restrictions ^(a)	Self-propelled		4	
		Non self-propelled			5
Cannot be put into a train		Self-propelled		6	
		Non self-propelled			7
Self-propelled rail/road vehicle than can be put into a train ^(b)				8	
Self-propelled rail/road vehicle than cannot be put into a train ^(b)				9	
Non self-propelled rail/road vehicle ^(b)					0

^(a) By restriction is meant a special position in a train (e.g. at the rear), an obligatory protection wagon, etc.

^(b) Special conditions concerning inclusion in a train must be complied with.

Type and sub-type of special vehicle (digits 7-8)

7th digit	8th digit	Vehicles/machines	7th digit	8th digit	Vehicles/machines
1 Infrastructure and superstructure	1	Track laying and renewal train	2 Track	1	High capacity plain track tamping machine
	2	Switches and crossing laying equipment		2	Other plain track tamping machines
	3	Track rehabilitation train		3	Tamping machine with stabilisation
	4	Ballast cleaning machine		4	Tamping machine for switches and crossings
	5	Earthworks machine		5	Ballast plough
	6			6	Stabilisation machine
	7			7	Grinding and welding machine
	8			8	Multi-purpose machine
	9	Rail-mounted crane (excl. rerailing)		9	Track inspection car
	0	Other or general		0	Other

7th digit	8th digit	Vehicles/machines
3 Overhead line	1	Multi-purpose machine
	2	Rolling and unrolling machine
	3	Mast installation machine
	4	Drum carrier machine
	5	Overhead line tensioning machine
	6	Machine with elevating work platform and machine with scaffold
	7	Cleaning train
	8	Greasing train
	9	Overhead line inspection car
	0	Other
4 Structures	1	Deck laying machine
	2	Bridge inspection platform
	3	Tunnel inspection platform
	4	Gas purification machine
	5	Ventilation machine
	6	Machine with elevating work platform or with scaffold
	7	Tunnel lighting machine
	8	
	9	
	0	Other
5 Loading, unloading and various transport	1	Rail loading/unloading and transport machine
	2	Loading/unloading and transport machine for ballast, gravel, etc.
	3	
	4	
	5	Sleeper loading/unloading and transport machine
	6	
	7	
	8	Loading/unloading and transport machine for switchgear, etc.
	9	Loading/unloading and transport machine for other materials
	0	Other

7th digit	8th digit	Vehicles/machines
6 Measuring	1	Earthworks recording car
	2	Track recording car
	3	Overhead line recording car
	4	Gauge recording car
	5	Signalling recording car
	6	Telecommunications recording car
	7	
	8	
	9	
	0	Other
7 Emergency	1	Emergency crane
	2	Emergency haulage car
	3	Emergency tunnel train
	4	Emergency car
	5	Fire car
	6	Sanitary vehicle
	7	Equipment car
	8	
	9	
	0	Other
8 Traction, transport, energy, etc.	1	Tractive units
	2	
	3	Transport car (excl. 59)
	4	Power car
	5	Track car/power car
	6	
	7	Concreting train
	8	
	9	
	0	Other

7th digit	8th digit	Vehicles/machines
9 Environment	1	Self-propelled snow plough
	2	Hauled snow plough
	3	Snow broom
	4	De-icing machine
	5	Weed-killing machine
	6	Rail cleaning machine
	7	
	8	
	9	
	0	Other

7th digit	8th digit	Vehicles/machines
0 Rail/road	1	Category 1 rail/road machine
	2	
	3	Category 2 rail/road machine
	4	
	5	Category 3 rail/road machine
	6	
	7	Category 4 rail/road machine
	8	
	9	
	0	Other

ANNEX P.12

Letter marking for wagons excluding articulated and multiple wagons

DEFINITION OF THE CATEGORY AND INDEX LETTERS

1. Important notes

In the attached tables:

- the information given in meters refers to the inside length of the wagons (lu);
- the information given in tonnes (tu) corresponds to the highest load limit shown in the loading table for the wagon in question, this limit being determined in accordance with the procedures laid down.

2. Index letters with an international value common to all categories

- q pipe for electric heating which can be supplied by all accepted currents
 qq pipe and installation for electric heating which can be supplied by all accepted currents
 s wagons authorised to run under 's' conditions (see annex B of Rolling Stock TSI)
 ss wagons authorised to run under 'ss' conditions (see annex B of Rolling Stock TSI)

3. Index letters with an national value

t, u, v, w, x, y, z

The value of these letters is defined by each Member State.

CATEGORY LETTER: E — OPEN HIGH-SIDED WAGON

Reference wagon	of ordinary type, with side and end tipping, with flat floor with 2 axles: $lu \geq 7,70$ m; $25 t \leq tu \leq 30 t$ with 4 axles: $lu \geq 12$ m; $50 t \leq tu \leq 60 t$ with 6 axles or more: $lu \geq 12$ m; $60 t \leq tu \leq 75 t$	
Index letters	a	with 4 axles
	aa	with 6 axles or more
	c	with floor traps ^(a)
	k	with 2 axles: $tu < 20 t$ with 4 axles: $tu < 40 t$ with 6 axles or more: $tu < 50 t$
	kk	with 2 axles: $20 t \leq tu < 25 t$ with 4 axles: $40 t \leq tu < 50 t$ with 6 axles or more: $50 t \leq tu < 60 t$
	l	without side tipping
	ll	without floor traps ^(b)
	m	with 2 axles: $lu < 7,70$ m with 4 axles or more: $lu < 12$ m
	mm	with 4 axles or more: $lu > 12$ m ^(b)
	n	with 2 axles: $tu > 30 t$ with 4 axles: $tu > 60 t$ with 6 axles or more: $tu > 75 t$
	o	without end tipping
	p	with station for brakeman ^(b)

^(a) This concept only applies to open high-sided wagons with a flat floor, and provided with a device enabling them to be used, either as ordinary wagons with a flat bottom, or for gravity unloading of certain goods by suitable positioning of the traps.

^(b) Only applicable to wagons with gauge of 1 520 mm.

CATEGORY LETTER: F — OPEN HIGH-SIDED WAGON

Reference wagon		Of special type with 2 axles: $25\text{ t} \leq tu \leq 30\text{ t}$ with 3 axles: $25\text{ t} \leq tu \leq 40\text{ t}$ with 4 axles: $50\text{ t} \leq tu \leq 60\text{ t}$ with 6 axles or more: $60\text{ t} \leq tu \leq 75\text{ t}$
Index letters	a	with 4 axles
	aa	with 6 axles or more
	b	high capacity with axles (volume > 45 m ³)
	c	with controlled gravity unloading, on both sides, alternately, at the top ^(a)
	cc	with controlled gravity unloading, on both sides, alternately, at the bottom ^(a)
	f	suitable for traffic with Great Britain
	ff	suitable for traffic with Great Britain (by tunnel exclusively)
	fff	suitable for traffic with Great Britain (by train-ferry exclusively)
	k	with 2 or 3 axles: $tu < 20\text{ t}$ with 4 axles: $tu < 40\text{ t}$ with 6 axles or more: $tu < 50\text{ t}$
	kk	with 2 or 3 axles: $20\text{ t} \leq tu < 25\text{ t}$ with 4 axles: $40\text{ t} \leq tu < 50\text{ t}$ with 6 axles or more: $50\text{ t} \leq tu < 60\text{ t}$
	l	with bulk gravity unloading, on both sides, simultaneously, at the top ^(a)
	ll	with bulk gravity unloading, on both sides, simultaneously, at the bottom ^(a)
	n	with 2 axles: $tu > 30\text{ t}$ with 3 axles or more: $tu > 40\text{ t}$ with 4 axles: $tu > 60\text{ t}$ with 6 axles or more: $tu > 75\text{ t}$
	o	with axial bulk gravity unloading, at the top ^(a)
	oo	with axial bulk gravity unloading, at the bottom ^(a)
	p	with axial controlled gravity unloading, at the top ^(a)
pp	with axial controlled gravity unloading, at the bottom ^(a)	
ppp	with station for brakeman ^(b)	

^(a) Wagons with gravity unloading in category F are open wagons, which do not have a flat floor and have no tipping facility either at the end or the side.

^(b) Only applicable to wagons with gauge of 1 520 mm.

The method of unloading these wagons is defined by a combination of the following characteristics:

Arrangement of the unloading apertures:

— axial: Apertures situated above the centre of the track

— bilateral: Apertures on either side of the track, outside the rails

(For these wagons, unloading is:

— simultaneous, if complete emptying of the wagon requires the apertures to be open on both sides,

— alternate, if complete emptying of the wagon can take place by opening the apertures on one side only)

— top: The lower edge of the discharge through (without taking into account mobile devices which may extend this through) is situated at least 0,700 m above the rail, and allows for the use of a conveyor belt to take away the goods

— bottom: The position of the lower edge of the discharge through does not allow for the use of a conveyor belt to take away the goods

Rate of unloading:

— bulk: Once the apertures are open for unloading, they cannot be closed again until the wagon is empty

— controlled: At any time during unloading, the flow of the goods can be regulated or even stopped

CATEGORY LETTER: G — COVERED WAGON

Reference wagon	Of ordinary type with at least 8 ventilation apertures with 2 axles: $9\text{ m} \leq lu < 12\text{ m}$; $25\text{ t} \leq tu \leq 30\text{ t}$ with 4 axles: $15\text{ m} \leq lu < 18\text{ m}$; $50\text{ t} \leq tu \leq 60\text{ t}$ with 6 axles or more: $15\text{ m} \leq lu < 18\text{ m}$; $60\text{ t} \leq tu \leq 75\text{ t}$	
Index letters	a	with 4 axles
	aa	with 6 axles or more
	b	high capacity: — with 2 axles: $lu \geq 12\text{ m}$ and payload capacity $\geq 70\text{ m}^3$ — with 4 axles or more: $lu \geq 18\text{ m}$
	bb	with 4 axles: $lu > 18\text{ m}$ ^(a)
	g	for grain
	h	for fruits and vegetables ^(b)
	k	with 2 axles: $tu < 20\text{ t}$ with 4 axles: $tu < 40\text{ t}$ with 6 axles or more: $tu < 50\text{ t}$
	kk	with 2 axles: $20\text{ t} \leq tu < 25\text{ t}$ with 4 axles: $40\text{ t} \leq tu < 50\text{ t}$ with 6 axles or more: $50\text{ t} \leq tu < 60\text{ t}$
	l	with less than 8 ventilation apertures
	ll	with enlarged doors apertures ^(a)
	m	with 2 axles: $lu < 9\text{ m}$ with 4 axles or more: $lu < 15\text{ m}$
	n	with 2 axles: $tu > 30\text{ t}$ with 4 axles: $tu > 60\text{ t}$ with 6 axles or more: $tu > 75\text{ t}$
	o	with 2 axles: $lu < 12\text{ m}$ and payload capacity $\geq 70\text{ m}^3$
	p	with station for brakeman ^(a)

^(a) Only applicable to wagons with gauge of 1 520 mm.

^(b) The concept 'for fruits and vegetables' applies only to wagons provided with additional ventilation apertures at the floor level.

CATEGORY LETTER: H — COVERED WAGON

Reference wagon		of special type with 2 axles: $9\text{ m} \leq lu \leq 12\text{ m}$; $25\text{ t} \leq tu \leq 28\text{ t}$ with 4 axles: $15\text{ m} \leq lu < 18\text{ m}$; $50\text{ t} \leq tu \leq 60\text{ t}$ with 6 axles or more: $15\text{ m} \leq lu < 18\text{ m}$; $60\text{ t} \leq tu \leq 75\text{ t}$
Index letters	a	with 4 axles
	aa	with 6 axles or more
	b	with 2 axles: $12\text{ m} \leq lu \leq 14\text{ m}$ and payload capacity $\geq 70\text{ m}^3$ ^(a) with 4 axles or more: $18\text{ m} \leq lu < 22\text{ m}$
	bb	with 2 axles: $lu \geq 14\text{ m}$ with 4 axles or more: $lu \geq 22\text{ m}$
	c	with end doors
	cc	with end doors and fitted internally for the transport of motor cars
	d	with floor traps
	dd	with tipping body ^(b)
	e	with 2 floors
	ee	with 3 floors or more
	f	suitable for traffic with Great Britain ^(a)
	ff	suitable for traffic with Great Britain (by tunnel exclusively)
	fff	suitable for traffic with Great Britain (by train-ferry exclusively) ^(a)
	g	for grain
	gg	for cement ^(b)
	h	for fruits and vegetables ^(c)
	hh	for mineral fertilizer ^(b)
	i	with opening or shunt walls
	ii	with very robust opening or shunt walls ^(d)
	k	with 2 axles: $tu < 20\text{ t}$ with 4 axles: $tu < 40\text{ t}$ with 6 axles or more: $tu < 50\text{ t}$
kk	with 2 axles: $20\text{ t} \leq tu < 25\text{ t}$ with 4 axles: $40\text{ t} \leq tu < 50\text{ t}$ with 6 axles or more: $50\text{ t} \leq tu < 60\text{ t}$	
l	with movable partitions ^(e)	
ll	with lockable movable partitions ^(e)	
m	with 2 axles: $lu < 9\text{ m}$ with 4 axles or more: $lu < 15\text{ m}$	
mm	with 4 axles or more: $lu > 18\text{ m}$ ^(b)	
n	with 2 axles: $tu > 28\text{ t}$ with 4 axles: $tu < 60\text{ t}$ with 6 axles or more: $tu > 75\text{ t}$	
o	with 2 axles: $lu\ 12\text{ m} < 14\text{ m}$ et volume utile $\geq 70\text{ m}^3$	
p	with station for brakeman ^(b)	

^(a) 2-axle wagons bearing the index letters 'f', 'fff' can have a payload capacity less than 70 m^3 .

^(b) Only applicable to wagons with gauge of 1 520 mm.

^(c) The concept 'for fruits and vegetables' applies only to wagons provided with additional ventilation apertures at the floor level.

^(d) Only applicable to wagons with gauge of 1 435 mm.

^(e) Movable partitions may be dismantled temporarily.

CATEGORY LETTER: I — TEMPERATURE-CONTROLLED WAGON

Reference wagon	refrigerator wagon with class IN thermal insulation, with motor-driven ventilation, with gratings and ice bunker $\geq 3,5 \text{ m}^3$ with 2 axles: $19 \text{ m}^2 \leq \text{floor area} < 22 \text{ m}^2$; $15 \text{ t} \leq \text{tu} \leq 25 \text{ t}$ with 4 axles: floor area $\geq 39 \text{ m}^2$; $30 \text{ t} \leq \text{tu} \leq 40 \text{ t}$	
Index letters	a	with 4 axles
	b	with 2 axles and large floor area: $22 \text{ m}^2 \leq \text{floor area} \leq 27 \text{ m}^2$
	bb	with 2 axles and very large floor area: floor area $> 27 \text{ m}^2$
	c	with meat hooks
	d	for fish
	e	with electric ventilation
	f	suitable for traffic with Great Britain
	ff	suitable for traffic with Great Britain (by tunnel exclusively)
	fff	suitable for traffic with Great Britain (by train-ferry exclusively)
	g	with mechanical refrigeration ^(a) ^(b)
	gg	refrigerator with liquefied gas ^(a)
	h	with class IR thermal insulation
	i	mechanically refrigerated by the machinery of an accompanying technical wagon ^(a) ^(b) ^(c)
	ii	accompanying technical wagon ^(a) ^(c)
	k	with 2 axles: $\text{tu} > 15 \text{ t}$ with 4 axles: $\text{tu} < 30 \text{ t}$
	l	insulated without ice bunkers ^(a) ^(d)
m	with 2 axles: floor area $< 19 \text{ m}^2$ with 4 axles: floor area $< 39 \text{ m}^2$	
mm	with 4 axles: floor area $\geq 39 \text{ m}^2$ ^(e)	
n	with 2 axles: $\text{tu} > 25 \text{ t}$ with 4 axles; $\text{tu} > 40 \text{ t}$	
o	with ice bunkers of capacity less than $3,5 \text{ m}^3$ ^(d)	
p	without gratings	

^(a) The index letter 'l' shall not be marked on wagons bearing the index letters 'g', 'gg', 'i' or 'ii'.

^(b) Wagons bearing both the index letters 'g' and 'i' can be used individually or in a mechanically refrigerated raft.

^(c) The concept of 'accompanying technical wagon' applies at the same time to factory wagons, workshop wagons (both with or without sleeping accommodation) and dormitory wagons.

^(d) The index letter 'o' shall not be marked on wagons bearing the index letter 'l'.

^(e) Only applicable to wagons with gauge of 1 520 mm.

Note: The floor area of covered refrigerator wagons is always determined taking into account the use of ice bunkers.

CATEGORY LETTER: K — 2-AXLE FLAT WAGON

Reference wagon	Of ordinary type with drop sides and short stanchions $lu \geq 12 \text{ m}; 25 \text{ t} \leq tu \leq 30 \text{ t}$	
Index letters	b	with long stanchions
	g	fitted for the transport of containers ^(a)
	i	with removable cover and non-removable ends ^(b)
	j	with shock-absorbing device
	k	$tu < 20 \text{ t}$
	kk	$20 \text{ t} \leq tu < 25 \text{ t}$
	l	without stanchions
	m	$9 \text{ m} \leq lu < 12 \text{ m}$
	mm	$lu < 9 \text{ m}$
	n	$tu > 30 \text{ t}$
	o	with non-removable sides
	p	without sides ^(b)
	pp	with removable sides

^(a) Index letter 'g' may be used together with category letter K exclusively for ordinary wagons which have only been additionally fitted out for the transport of containers. Wagons fitted out solely for the transport of containers must be classified in category L.

^(b) The index letter 'p' shall not be marked on wagons bearing index letter 'i'.

CATEGORY LETTER: L — 2-AXLE FLAT WAGON

Reference wagon		of special type lu ≥ 12 m; 25 t ≤ tu ≤ 30 t
Index letters	b	with special fittings for securing purposes for medium-sized containers (pa) ^(a)
	c	with swivelling bolster ^(a)
	d	fitted out for the transport of motor cars, without deck ^(a)
	e	with decks for the transport of motor cars ^(a)
	f	suitable for traffic with Great Britain
	ff	suitable for traffic with Great Britain (by tunnel exclusively)
	fff	suitable for traffic with Great Britain (by train-ferry exclusively)
	g	fitted for the transport of containers (except pa) ^(a) ^(b)
	h	fitted out for the transport of steel coils, eye to side ^(a) ^(c)
	hh	fitted out for the transport of steel coils, eye to sky ^(a) ^(c)
	i	with removable cover and non-removable ends ^(a)
	ii	with very robust removable metallic cover ^(d) and non-removable ends ^(a)
	j	with shock-absorbing device
	k	tu < 20 t
	kk	20 t ≤ tu < 25 t
	l	without stanchions ^(a)
	m	9 m ≤ lu < 12 m
mm	lu < 9 m	
n	tu > 30 t	
p	without sides ^(a)	

^(a) The inscription of the index letters 'l' or 'p' is optional for wagons bearing the index letters 'b', 'c', 'd', 'e', 'g', 'h', 'hh', 'i' or 'ii'. But numerical codes must always correspond to letter markings on wagons.

^(b) Wagons used solely for the transport of containers (except pa).

^(c) Wagons used solely for the transport of steel coils.

^(d) Only applicable to wagons with gauge of 1 435 mm.

CATEGORY LETTER: O — MIXED FLAT AND OPEN HIGH
-SIDED WAGON

Reference wagon		of ordinary type with 2 or 3 axles, with drop sides or ends and stanchions with 2 axles: $lu \geq 12$ m; 25 t \leq $tu \leq 30$ t with 3 axles: $lu \geq 12$ m; 25 t \leq $tu \leq 40$ t
Index letters	a	with 3 axles
	f	suitable for traffic with Great Britain
	ff	suitable for traffic with Great Britain (by tunnel exclusively)
	fff	suitable for traffic with Great Britain (by train-ferry exclusively)
	k	$tu < 20$ t
	kk	20 t \leq $tu < 25$ t
	l	without stanchions
	m	9 m \leq $lu < 12$ m
	mm	$lu < 9$ m
	n	with 2 axles: $tu > 30$ t with 3 axles: $tu > 40$ t

CATEGORY LETTER: R — FLAT BOGIES WAGON

Reference wagon	of ordinary type with drop ends and stanchions $18\text{ m} \leq lu < 22\text{ m}$; $50\text{ t} \leq tu \leq 60\text{ t}$	
Index letters	b	$lu \geq 22\text{ m}$
	e	with drop sides
	g	fitted for the transport of containers ^(a)
	h	fitted out for the transport of steel coils, eye to side ^(b)
	hh	fitted out for the transport of steel coils, eye to sky ^(b)
	i	with removable cover and non-removable ends ^(c)
	j	with shock-absorbing device
	k	$tu < 40\text{ t}$
	kk	$40\text{ t} \leq tu < 50\text{ t}$
	l	without stanchions
	m	$15\text{ m} \leq lu < 18\text{ m}$
	mm	$lu < 15\text{ m}$
	n	$tu > 60\text{ t}$
	o	with non-removable ends less than 2 m in height
	oo	with non-removable ends, 2 m or more in height ^(c)
	p	without drop ends ^(c)
pp	with removable sides	

^(a) The use of the index letter 'g' associated with the category letter R is only possible in the case of ordinary wagons which have only been additionally fitted out for the transport of containers. Wagons fitted out solely for the transport of containers must be classified in category S.

^(b) The use of the index letter 'h' or 'hh' together with the category letter R is only possible in the case of ordinary wagons which have only been additionally fitted out for the transport of containers. Wagons fitted out solely for the transport of containers must be classified in category S.

^(c) The index letters 'oo' and/or 'p' shall not be marked on wagons bearing index letter 'i'.

CATEGORY LETTER: S — FLAT BOGIES WAGON

Reference wagon		of special type with 4 axles: $lu \geq 18$ m; 50 t $\leq tu \leq 60$ t with 6 axles or more: $lu \geq 22$ m; 60 t $\leq tu \leq 75$ t
Index letters	a	with 6 axles (2 bogies of 3 axles)
	aa	with 8 axles or more
	aaa	with 4 axles (2 bogies of 2 axles) ^(a)
	b	with special fittings for securing purposes for medium-sized containers (pa) ^(b)
	c	with swivelling bolster ^(b)
	d	fitted out for the transport of motor cars, without deck ^(b) ^(c)
	e	with decks for the transport of motor cars ^(b)
	f	suitable for traffic with Great Britain
	ff	suitable for traffic with Great Britain (by tunnel exclusively)
	fff	suitable for traffic with Great Britain (by train-ferry exclusively)
	g	fitted for the transport of containers, total loading length $\leq 60'$ (except pa) ^(b) ^(c) ^(d)
	gg	fitted for the transport of containers, total loading length $> 60'$ (except pa) ^(b) ^(c) ^(d)
	h	fitted out for the transport of steel coils, eye to side ^(b) ^(c)
	hh	fitted out for the transport of steel coils, eye to sky ^(b) ^(c)
	i	with removable cover and non-removable ends ^(b)
	ii	with very robust removable metallic cover ^(f) and non-removable ends ^(b)
	j	with shock-absorbing device
	k	with 4 axles: $tu < 40$ t with 6 axles or more: $tu < 50$ t
	kk	with 4 axles: 40 t $\leq tu < 50$ t with 6 axles or more: 50 t $\leq tu < 60$ t
	l	without stanchions ^(b)
m	with 4 axles: 15 m $\leq lu < 18$ m; with 6 axles or more: 18 m $\leq lu < 22$ m	
mm	with 4 axles: $lu < 15$ m with 6 axles or more: $lu < 18$ m	
mmm	with 4 axles: $lu \geq 22$ m ^(a)	
n	with 4 axles: $tu > 60$ t with 6 axles or more: $tu > 75$ t	
p	without sides ^(b)	

^(a) Only applicable to wagons with gauge of 1 520 mm.

^(b) The inscription of the index letters 'l' or 'p' is optional for wagons bearing the index letters 'b', 'c', 'd', 'e', 'g', 'gg', 'h', 'hh', 'i' or 'ii'. But numerical codes must always correspond to letter markings on wagons.

^(c) Wagons which in addition to the transport of containers and swap bodies are used to transport vehicles shall be marked with the index letters 'g' or 'gg' and the letter 'd'.

^(d) Wagons used solely for the transport of containers or for transport of swap bodies for grab handling and spreader gripping.

^(e) Wagons used solely for the transport of steel coils.

^(f) Only applicable to wagons with gauge of 1 435 mm.

CATEGORY LETTER: T — WAGON WITH OPENING ROOF

Reference wagon		with 2 axles: $9\text{ m} \leq lu < 12\text{ m}$; $25\text{ t} \leq tu \leq 30\text{ t}$ with 4 axles: $15\text{ m} \leq lu < 18\text{ m}$; $50\text{ t} \leq tu \leq 60\text{ t}$ with 6 axles or more: $15\text{ m} \leq lu < 18\text{ m}$; $60\text{ t} \leq tu \leq 75\text{ t}$
Index letters	a	with 4 axles
	aa	with 6 axles or more
	b	high capacity: with 2 axles: $lu \geq 12\text{ m}$ with 4 axles or more: $lu \geq 18\text{ m}$ ^(a) ^(b)
	c	with end doors
	d	with controlled gravity unloading, on both sides, alternately, at the top ^(a) ^(b) ^(c)
	dd	with controlled gravity unloading, on both sides, alternately, at the bottom ^(a) ^(b) ^(c)
	e	with unobstructed height of the doors $> 1,90\text{ m}$ ^(a) ^(b) ^(c)
	f	suitable for traffic with Great Britain
	ff	suitable for traffic with Great Britain (by tunnel exclusively)
	fff	suitable for traffic with Great Britain (by train-ferry exclusively)
	g	for grain
	h	fitted out for the transport of steel coils, eye to side
	hh	fitted out for the transport of steel coils, eye to sky
	i	with opening walls ^(a)
	j	with shock-absorbing device
	k	with 2 axles: $tu < 20\text{ t}$ with 4 axles: $tu < 40\text{ t}$ with 6 axles or more: $tu < 50\text{ t}$
	kk	with 2 axles: $20\text{ t} \leq tu < 25\text{ t}$ with 4 axles: $40\text{ t} \leq tu < 50\text{ t}$ with 6 axles or more: $50\text{ t} \leq tu < 60\text{ t}$
	l	with bulk gravity unloading, on both sides, simultaneously, at the top ^(a) ^(b) ^(c)
	ll	with bulk gravity unloading, on both sides, simultaneously, at the bottom ^(a) ^(b) ^(c)
	m	with 2 axles: $lu < 9\text{ m}$ with 4 axles or more: $lu < 15\text{ m}$ ^(b)
n	with 2 axles: $tu > 30\text{ t}$ with 4 axles: $tu > 60\text{ t}$ with 6 axles or more: $tu > 75\text{ t}$	
o	with axial bulk gravity unloading, at the top ^(a) ^(b) ^(c)	
oo	with axial bulk gravity unloading, at the bottom ^(a) ^(b) ^(c)	
p	with axial controlled gravity unloading, at the top ^(a) ^(b) ^(c)	
pp	with axial controlled gravity unloading, at the bottom ^(a) ^(b) ^(c)	

^(a) Index letter 'e':

- is optional on wagons bearing the index letter 'b' (but numerical codes must always correspond to letter markings on wagons),
- shall not be marked on wagons bearing the index letters 'd', 'dd', 'i', 'l', 'll', 'o', 'oo', 'p' or 'pp'.

^(b) Index letter 'b' and 'm' shall not be marked on wagons bearing the index letters 'd', 'dd', 'l', 'll', 'o', 'oo', 'p' or 'pp'.

^(c) Wagons with gravity unloading in category T are wagons fitted with an opening roof giving access to a loading hatch over the complete length of the body; these wagons do not have a flat floor and are not designed for end or side tipping.

The method of unloading these wagons is defined by a combination of the following characteristics:

Arrangement of the unloading apertures:

- axial: Apertures situated above the centre of the track
- bilateral: Apertures on either side of the track, outside the rails
(For these wagons, unloading is:
 - simultaneous, if complete emptying of the wagon requires the apertures to be open on both sides,
 - alternate, if complete emptying of the wagon can take place by opening the apertures on one side only)
- top: The lower edge of the discharge through (without taking into account mobile devices which may extend this through) is situated at least 0,700 m above the rail, and allows for the use of a conveyor belt to take away the goods
- bottom: The position of the lower edge of the discharge through does not allow for the use of a conveyor belt to take away the goods

Rate of unloading:

- bulk: Once the apertures are open for unloading, they cannot be closed again until the wagon is empty
- controlled: At any time during unloading, the flow of the goods can be regulated or even stopped

CATEGORY LETTER: U — SPECIAL WAGONS

Reference wagon		other than those in categories F, H, L, S ou Z with 2 axles: $25 t \leq tu \leq 30 t$ with 3 axles: $25 t \leq tu \leq 40 t$ with 4 axles: $50 t \leq tu \leq 60 t$ with 6 axles or more: $60 t \leq tu \leq 75 t$
Index letters	a	with 4 axles
	aa	with 6 axles or more
	c	with unloading under pressure
	d	with controlled gravity unloading, on both sides, alternately, at the top ^(a)
	dd	with controlled gravity unloading, on both sides, alternately, at the bottom ^(a)
	f	suitable for traffic with Great Britain
	ff	suitable for traffic with Great Britain (by tunnel exclusively)
	fff	suitable for traffic with Great Britain (by train-ferry exclusively)
	g	for grain
	i	fitted out for the transport of objects which should exceed the gauge if they were loaded on ordinary wagons ^(b) ^(c)
	k	with 2 or 3 axles: $tu < 20 t$ with 4 axles: $tu < 40 t$ with 6 axles or more: $tu < 50 t$
	kk	with 2 or 3 axles: $20 t \leq tu < 25 t$ with 4 axles: $40 t \leq tu < 50 t$ with 6 axles or more: $50 t \leq tu < 60 t$
	l	with bulk gravity unloading, on both sides, simultaneously, at the top ^(a)
	ll	with bulk gravity unloading, on both sides, simultaneously, at the bottom ^(a)
	n	with 2 axles: $tu > 30 t$ with 3 axles: $tu > 40 t$ with 4 axles: $tu > 60 t$ with 6 axles or more: $tu > 75 t$ ^(c)
	o	with axial bulk gravity unloading, at the top ^(a)
oo	with axial bulk gravity unloading, at the bottom ^(a)	
p	with axial bulk gravity unloading, at the top ^(a)	
pp	with axial bulk gravity unloading, at the bottom ^(a)	

^(a) Wagons with gravity unloading in category U are closed wagons which can only be loaded through one or more loading apertures situated in at the top part of the body, and whose total opening dimensions are less than the length of the body; these wagons do not have a flat floor and are not designed for end or side tipping.

^(b) In particular:

- well wagons
- wagons with a central recess
- wagons with an ordinary sloping diagonal permanent control desk

^(c) Index letter 'n' shall not be marked on wagons bearing the index letter 'i'.

The method of unloading these wagons is defined by a combination of the following characteristics:

Arrangement of the unloading apertures:

- axial: Apertures situated above the centre of the track
- bilateral: Apertures on either side of the track, outside the rails

(For these wagons, unloading is:

- simultaneous, if complete emptying of the wagon requires the apertures to be open on both sides,
- alternate, if complete emptying of the wagon can take place by opening the apertures on one side only)

— top: The lower edge of the discharge through (without taking into account mobile devices which may extend this through) is situated at least 0,700 m above the rail, and allows for the use of a conveyor belt to take away the goods

— bottom: The position of the lower edge of the discharge through does not allow for the use of a conveyor belt to take away the goods

Rate of unloading:

- bulk: Once the apertures are open for unloading, they cannot be closed again until the wagon is empty
- controlled: At any time during unloading, the flow of the goods can be regulated or even stopped

CATEGORY LETTER: Z — TANK WAGON

Reference wagon		with metal shell, for the transport of liquids or gases with 2 axles: $25 \text{ t} \leq \text{lu} \leq 30 \text{ t}$ with 3 axles: $25 \text{ t} \leq \text{tu} \leq 40 \text{ t}$ with 4 axles: $50 \text{ t} \leq \text{tu} \leq 60 \text{ t}$ with 6 axles or more: $60 \text{ t} \leq \text{tu} \leq 75 \text{ t}$
Index letters	a	with 4 axles
	aa	with 6 axles or more
	b	for oil products ^(a)
	c	with unloading under pressure ^(b)
	d	for food and chemical products ^(a)
	e	fitted with heating devices
	f	suitable for traffic with Great Britain
	ff	suitable for traffic with Great Britain (by tunnel exclusively)
	fff	suitable for traffic with Great Britain (by train-ferry exclusively)
	g	for the transport of gases under pressure, liquefied or dissolved under pressure ^(b)
	i	tank of non-metallic material
	j	with shock-absorbing device
	k	with 2 or 3 axles: $\text{tu} < 20 \text{ t}$ with 4 axles: $\text{tu} < 40 \text{ t}$ with 6 axles or more: $\text{tu} < 50 \text{ t}$
	kk	with 2 or 3 axles: $20 \text{ t} \leq \text{tu} < 25 \text{ t}$ with 4 axles: $40 \text{ t} \leq \text{tu} < 50 \text{ t}$ with 6 axles or more: $50 \text{ t} \leq \text{tu} < 60 \text{ t}$
	n	with 2 axles: $\text{tu} > 30 \text{ t}$ with 3 axles: $\text{tu} > 40 \text{ t}$ with 4 axles: $\text{tu} > 60 \text{ t}$ with 6 axles or more: $\text{tu} > 75 \text{ t}$
p	with station for brakeman ^(a)	

^(a) Only applicable to wagons with gauge of 1 520 mm.

^(b) The index letter 'c' shall not be marked on wagons bearing the index letter 'g'.

LETTER MARKING FOR WAGONS FOR ARTICULATED AND MULTIPLE WAGONS

DEFINITION OF THE CATEGORY AND INDEX LETTERS

1. Important notes

In the attached tables, the information given in meters refers to the inside length of the wagons (lu).

2. Index letters with an international value common to all categories

q	pipe for electric heating which can be supplied by all accepted currents
qq	pipe and installation for electric heating which can be supplied by all accepted currents
s	wagons authorised to run under 's' conditions (see annex B of rolling stock STI)
ss	wagons authorised to run under 'ss' conditions (see annex B of rolling stock STI)

3. Index letters with a national value

t, u, v, w, x, y, z

The value of these letters is defined by each Member State.

CATEGORY LETTER: F — OPEN HIGH-SIDED WAGON

Reference wagon	Articulated or multiple wagon with axles, with 2 units $22\text{ m} \leq \text{lu} < 27\text{ m}$	
Index letters	a	with bogies
	c	with controlled gravity unloading, on both sides, alternately, at the top ^(a)
	cc	with controlled gravity unloading, on both sides, alternately, at the bottom ^(a)
	e	with 3 units
	ee	with 4 units or more
	f	suitable for traffic with Great Britain
	ff	suitable for traffic with Great Britain (by tunnel exclusively)
	fff	suitable for traffic with Great Britain (by train-ferry exclusively)
	l	with bulk gravity unloading, on both sides, simultaneously, at the top ^(a)
	ll	with bulk gravity unloading, on both sides, simultaneously, at the bottom ^(a)
	m	with 2 units: $\text{lu} \geq 27\text{ m}$
	mm	with 2 units: $\text{lu} < 22\text{ m}$
	o	with axial bulk gravity unloading, at the top ^(a)
	oo	with axial bulk gravity unloading, at the bottom ^(a)
	p	with axial controlled gravity unloading, at the top ^(a)
	pp	with axial controlled gravity unloading, at the bottom ^(a)
	r	articulated wagon
rr	multiple wagon	

^(a) Wagons with gravity unloading in category F are open wagons, which do not have a flat floor and are not designed for end or side tipping.

The method of unloading these wagons is defined by a combination of the following characteristics:

Arrangement of the unloading apertures:

— axial: Apertures situated above the centre of the track

— bilateral: Apertures on either side of the track, outside the rails

(For these wagons, unloading is:

— simultaneous, if complete emptying of the wagon requires the apertures to be open on both sides,

— alternate, if complete emptying of the wagon can take place by opening the apertures on one side only)

— top: The lower edge of the discharge through (without taking into account mobile devices which may extend this through) is situated at least 0,700 m above the rail, and allows for the use of a conveyor belt to take away the goods

— bottom: The position of the lower edge of the discharge through does not allow for the use of a conveyor belt to take away the goods

Rate of unloading:

— bulk: Once the apertures are open for unloading, they cannot be closed again until the wagon is empty

— controlled: At any time during unloading, the flow of the goods can be regulated or even stopped

CATEGORY LETTER: H — COVERED WAGON

Reference wagon	articulated or multiple wagon with axles, with 2 units $22\text{ m} \leq l_u < 27\text{ m}$	
Index letters	a	with bogies
	c	with end doors
	cc	with end doors and fitted internally for the transport of motor cars
	d	with floor traps
	e	with 3 units
	ee	with 4 units or more
	f	suitable for traffic with Great Britain
	ff	suitable for traffic with Great Britain (by tunnel exclusively)
	fff	suitable for traffic with Great Britain (by train-ferry exclusively)
	g	for grain
	h	for fruits and vegetables ^(a)
	i	with opening or shunt walls
	ii	with very robust opening or shunt walls ^(b)
	l	with movable partitions ^(c)
	ll	with lockable movable partitions ^(c)
	m	with 2 units: $l_u \geq 27\text{ m}$
	mm	with 2 units: $l_u < 22\text{ m}$
r	articulated wagon	
rr	multiple wagon	

^(a) The concept 'for fruits and vegetables' applies only to wagons provided with additional ventilation apertures at the floor level.

^(b) Only applicable to wagons with gauge of 1 435 mm.

^(c) Movable partitions may be dismantled temporarily.

CATEGORY LETTER: I — TEMPERATURE CONTROLLED WAGON

Reference wagon		refrigerator wagon with class IN thermal insulation, with motor-driven ventilation, with gratings and ice bunker $\geq 3,5 \text{ m}^3$ articulated or multiple wagon with axles, with 2 units $22 \text{ m} \leq \text{lu} < 27 \text{ m}$
Index letters	a	with bogies
	c	with meat hooks
	d	for fish
	e	with electric ventilation
	ee	with 4 units or more
	f	suitable for traffic with Great Britain
	ff	suitable for traffic with Great Britain (by tunnel exclusively)
	fff	suitable for traffic with Great Britain (by train-ferry exclusively)
	g	with mechanical refrigeration ^(a)
	gg	refrigerator with liquefied gas ^(a)
	h	with class IR thermal insulation
	i	mechanically refrigerated by the machinery of an accompanying technical wagon ^(a) ^(b)
	ii	accompanying technical wagon ^(a) ^(b)
	l	insulated without ice bunkers ^(a) ^(c)
	m	with 2 units: $\text{lu} \geq 27 \text{ m}$
	mm	with 2 units: $\text{lu} < 22 \text{ m}$
	o	with ice bunkers of capacity less than $3,5 \text{ m}^3$ ^(c)
	oo	with 3 units
	p	without gratings
r	articulated wagon	
rr	multiple wagon	

^(a) The index letter 'l' shall not be marked on wagons bearing the index letters 'g', 'gg', 'i' or 'ii'.

^(b) The concept of 'accompanying technical wagon' applies at the same time to factory wagons, workshop wagons (both with or without sleeping accommodation) and dormitory wagons.

^(c) The index letter 'o' shall not be marked on wagons bearing the index letter 'l'.

CATEGORY LETTER: L — FLAT WAGON WITH SEPARATE AXLES

Reference wagon	articulated or multiple wagon with 2 units $22\text{ m} \leq l_u < 27\text{ m}$	
Index letters	a	articulated wagon
	aa	multiple wagon
	b	with special fittings for securing purposes for medium-sized containers (pa) ^(a)
	c	with swivelling bolster ^(a)
	d	fitted out for the transport of motor cars, without deck ^(a)
	e	with decks for the transport of motor cars ^(a)
	f	suitable for traffic with Great Britain
	ff	suitable for traffic with Great Britain (by tunnel exclusively)
	fff	suitable for traffic with Great Britain (by train-ferry exclusively)
	g	fitted for the transport of containers ^(a) ^(b)
	h	fitted out for the transport of steel coils, eye to side ^(a) ^(c)
	hh	fitted out for the transport of steel coils, eye to sky ^(a) ^(c)
	i	with removable cover and non-removable ends ^(a)
	ii	with very robust removable metallic cover ^(d) and non-removable ends ^(a)
	j	with shock-absorbing device
	l	without stanchions ^(a)
	m	with 2 units: $18\text{ m} \leq l_u < 22\text{ m}$
	mm	with 2 units: $l_u < 18\text{ m}$
	o	with 3 units
	oo	with 4 units or more
p	without sides ^(a)	
r	with 2 units: $l_u \geq 27\text{ m}$	

^(a) The inscription of the index letters 'l' or 'p' is optional for wagons bearing the index letters 'b', 'c', 'd', 'e', 'g', 'h', 'hh', 'i' or 'ii'. But numerical codes must always correspond to letter markings on wagons.

^(b) Wagons used solely for the transport of containers (except pa).

^(c) Wagons used solely for the transport of steel coils.

^(d) Only applicable to wagons with gauge of 1 435 mm.

CATEGORY LETTER: S — FLAT BOGIE WAGON

Reference wagon	articulated or multiple wagon with 2 units $22\text{ m} \leq \text{lu} < 27\text{ m}$	
Index letters	b	with special fittings for securing purposes for medium-sized containers (pa) ^(a)
	c	with swivelling bolster ^(a)
	d	fitted out for the transport of motor cars, without deck ^(a) ^(b)
	e	with decks for the transport of motor cars ^(a)
	f	suitable for traffic with Great Britain
	ff	suitable for traffic with Great Britain (by tunnel exclusively)
	fff	suitable for traffic with Great Britain (by train-ferry exclusively)
	g	fitted for the transport of containers, total loading length $\leq 60'$ (except pa) ^(a) ^(b) ^(c)
	gg	fitted for the transport of containers, total loading length $> 60'$ (except pa) ^(a) ^(b) ^(c)
	h	fitted out for the transport of steel coils, eye to side ^(a) ^(d)
	hh	fitted out for the transport of steel coils, eye to sky ^(a) ^(d)
	i	with removable cover and non-removable ends ^(a)
	ii	with very robust removable metallic cover ^(c) and non-removable ends ^(a)
	j	with shock-absorbing device
	l	without stanchions ^(a)
	m	with 2 units: $\text{lu} \geq 27\text{ m}$
	mm	with 2 units: $\text{lu} < 22\text{ m}$
	o	with 3 units
	oo	with 4 units or more
	p	without sides ^(a)
r	articulated wagon	
rr	multiple wagon	

^(a) The inscription of the index letters 'l' or 'p' is optional for wagons bearing the index letters 'b', 'c', 'd', 'e', 'g', 'gg', 'h', 'hh', 'i' or 'ii'. But numerical codes must always correspond to letter markings on wagons.

^(b) Wagons which in addition to the transport of containers and swap bodies are used to transport vehicles shall be marked with the index letters 'g' or 'gg' and the letter 'd'.

^(c) Wagons used solely for the transport of containers or for transport of swap bodies for grab handling and spreader gripping.

^(d) Wagons used solely for the transport of steel coils.

^(e) Only applicable to wagons with gauge of 1 435 mm.

CATEGORY LETTER: T — WAGON WITH OPENING ROOF

Reference wagon	articulated or multiple wagon with axles, with 2 units $22\text{ m} \leq lu < 27\text{ m}$	
Index letters	a	with bogies
	b	with unobstructed height of doors $> 1,90\text{ m}$ ^(a)
	c	with end doors
	d	with controlled gravity unloading, on both sides, alternately, at the top ^(a) ^(b)
	dd	with controlled gravity unloading, on both sides, alternately, at the bottom ^(a) ^(b)
	e	with 3 units
	ee	with 4 units or more
	f	suitable for traffic with Great Britain
	ff	suitable for traffic with Great Britain (by tunnel exclusively)
	fff	suitable for traffic with Great Britain (by train-ferry exclusively)
	g	for grain
	h	fitted out for the transport of steel coils, eye to side
	hh	fitted out for the transport of steel coils, eye to sky
	i	with opening walls ^(a)
	j	with shock-absorbing device
	l	with bulk gravity unloading, on both sides, simultaneously, at the top ^(a) ^(b)
	ll	with bulk gravity unloading, on both sides, simultaneously, at the bottom ^(a) ^(b)
	m	with 2 units: $lu \geq 27\text{ m}$
	mm	with 2 units: $lu < 22\text{ m}$
	o	with axial bulk gravity unloading, at the top ^(a) ^(b)
oo	with axial bulk gravity unloading, at the bottom ^(a) ^(b)	
p	with axial controlled gravity unloading, at the top ^(a) ^(b)	
pp	with axial controlled gravity unloading, at the bottom ^(a) ^(b)	
r	articulated wagon	
rr	multiple wagon	

^(a) Index letter 'b' shall not be marked on wagons bearing the index letters 'd', 'dd', 'i', 'l', 'll', 'o', 'oo', 'p' or 'pp'.

^(b) Wagons with gravity unloading in category T are wagons fitted with an opening roof giving access to a loading hatch over the complete length of the body; these wagons do not have a flat floor and are not designed for end or side tipping.

The method of unloading these wagons is defined by a combination of the following characteristics:

Arrangement of the unloading apertures:

— axial: Apertures situated above the centre of the track

— bilateral: Apertures on either side of the track, outside the rails

(For these wagons, unloading is:

— simultaneous, if complete emptying of the wagon requires the apertures to be open on both sides,

— alternate, if complete emptying of the wagon can take place by opening the apertures on one side only)

— top: The lower edge of the discharge through (without taking into account mobile devices which may extend this through) is situated at least 0,700 m above the rail, and allows for the use of a conveyor belt to take away the goods

— bottom: The position of the lower edge of the discharge through does not allow for the use of a conveyor belt to take away the goods

Rate of unloading:

— bulk: Once the apertures are open for unloading, they cannot be closed again until the wagon is empty

— controlled: At any time during unloading, the flow of the goods can be regulated or even stopped

CATEGORY LETTER: U — SPECIAL WAGONS

Reference wagon	articulated or multiple wagon, with axles, with 2 units $22\text{ m} \leq lu < 27\text{ m}$	
Index letters	a	with bogies
	e	with 3 units
	ee	with 4 units or more
	c	with unloading under pressure
	d	with controlled gravity unloading, on both sides, alternately, at the top ^(a)
	dd	with controlled gravity unloading, on both sides, alternately, at the bottom ^(a)
	f	suitable for traffic with Great Britain
	ff	suitable for traffic with Great Britain (by tunnel exclusively)
	fff	suitable for traffic with Great Britain (by train-ferry exclusively)
	g	for grain
	i	fitted out for the transport of objects which should exceed the gauge if they were loaded on ordinary wagons ^(b)
	l	with bulk gravity unloading, on both sides, simultaneously, at the top ^(a)
	ll	with bulk gravity unloading, on both sides, simultaneously, at the bottom ^(a)
	m	with 2 units: $lu \geq 27\text{ m}$
	mm	with 2 units: $lu < 22\text{ m}$
	o	with axial bulk gravity unloading, at the top ^(a)
	oo	with axial bulk gravity unloading, at the bottom ^(a) ^(b)
	p	with axial controlled gravity unloading, at the top ^(a)
	pp	with axial controlled gravity unloading, at the bottom ^(a)
r	articulated wagon	
rr	multiple wagon	

^(a) Wagons with gravity unloading in category U are closed wagons which can only be loaded through one or more loading apertures situated in at the top part of the body, and whose total opening dimensions are less than the length of the body; these wagons do not have a flat floor and are not designed for end or side tipping.

^(b) In particular:

- well wagons
- wagons with a central recess
- wagons with an ordinary sloping diagonal permanent control desk

The method of unloading these wagons is defined by a combination of the following characteristics:

Arrangement of the unloading apertures:

— axial: Apertures situated above the centre of the track

— bilateral: Apertures on either side of the track, outside the rails.

(For these wagons, unloading is:

- simultaneous, if complete emptying of the wagon requires the apertures to be open on both sides,
- alternate, if complete emptying of the wagon can take place by opening the apertures on one side only)

— top: The lower edge of the discharge through (without taking into account mobile devices which may extend this through) is situated at least 0,700 m above the rail, and allows for the use of a conveyor belt to take away the goods

— bottom: The position of the lower edge of the discharge through does not allow for the use of a conveyor belt to take away the goods

Rate of unloading:

- bulk: Once the apertures are open for unloading, they cannot be closed again until the wagon is empty
- controlled: At any time during unloading, the flow of the goods can be regulated or even stopped

CATEGORY LETTER: Z — TANK WAGON

Reference wagon		with metal shell, for the transport of liquids or gases articulated or multiple wagon with axles, with 2 units $22\text{ m} \leq \text{lu} < 27\text{ m}$
Index letters	a	with bogies
	c	with unloading under pressure ^(a)
	e	fitted with heating devices
	f	suitable for traffic with Great Britain
	ff	suitable for traffic with Great Britain (by tunnel exclusively)
	fff	suitable for traffic with Great Britain (by train-ferry exclusively)
	g	for the transport of gases under pressure, liquefied or dissolved under pressure ^(a)
	i	tank of non-metallic material
	j	with shock-absorbing device
	m	with 2 units: $\text{lu} \geq 27\text{ m}$
	mm	with 2 units: $\text{lu} < 22\text{ m}$
	o	with 3 units
	oo	with 4 units or more
	r	articulated wagon
rr	multiple wagon	

^(a) The index letter 'c' shall not be marked on wagons bearing the index letter 'g'.

ANNEX P.13

Letter marking for hauled passenger stock**Serial letters with an international value:**

A	1 st class coach with seats
B	2 nd class coach with seats
AB	1 st /2 nd class coach with seats
WL	Sleeping-car with serial letter A, B or AB depending on the type of accommodation offered. The serial letters for sleeping-car with 'special' compartments are supplemented with index-letter 'S'
WR	Dining-car
R	Coach with dining-car, buffet or bar compartment (serial-letter used in addition)
D	Van
DD	Open, 2-tier car-carrier van
Post	Mail van
AS	Bar coach with dancing facilities
SR	
WG	
WSP	Pullman coach
Le	Open 2-axle 2-tier car-carrier wagon
Leq	Open 2-axle 2-tier car-carrier wagon fitted with train supply cable
Laeq	Open 3-axle 2-tier car-carrier wagon fitted with train supply cable

Index letters with an international value:

b h	Coach fitted out to carry disabled passengers
c	Compartments convertible into couchette accommodation
d v	Vehicle fitted to receive bicycles
ee z	Vehicle fitted with central power supply
f	Vehicle fitted with driver's cab (driving trailer)
p t	Centre-aisle coach with seats
m	Vehicle over 24,5 m in length
s	Centre-aisle in vans and coaches with luggage compartment

The number of compartments is shown in the form of an index (for example: Bc9)

Serial letters and index letters with a national value

The others serial letters and index letters have a national value, defined by each Member State.

ANNEX P.14

Letter marking for special vehicles

This marking is indicated in document EN 14033-1 'Railway applications — Track — Technical requirements for railbound construction and maintenance machines — Part 1: Running of railbound machines'.

—

ANNEX Q

Not used

—

ANNEX R

Train identification

An EN is being developed in this area. Once it has been introduced, its suitability as a means by which compliance with the requirements of this TSI can be assured, will be assessed by the ERA and the EC.

Until this EN has been developed, this Annex contains the CWA prepared in this regard.

It should be noted that this CWA does not remove the applicability of UIC leaflets 419-1 and 419-2.

Please refer to the attached document — CWA on train numbering

—

ANNEX S

Not Used

—

ANNEX T

Brake performance

A detailed specification is being defined which will set out the formula for the calculation of brake performance. This specification shall be valid across the TEN and shall take into account how best such a formula can be established to permit the working of brakes to be harmonised safely and in a cost-effective manner. An expert, multi-disciplined drafting group is taking this forward. It will also work in conjunction with the requirements of the CR OPE TSI as well.

Until the detailed specifications can be developed and introduced, this is an Open Point and it is recommended that Railway Undertakings and Infrastructure Managers liaise to jointly establish bilateral or multilateral agreements to facilitate the unhindered passage of trains from one Infrastructure Manager's operating area to another.

See also Annex U.

ANNEX U

List of open points

CLAUSE 4.2.2.5

Train composition document

ANNEX T (see Subsection 4.2.2.6.2 of this TSI)

Brake Performance

ANNEX V

Preparation and updating rules documentation for drivers

In conjunction with Subsections 4.2 and 4.6 of this TSI, the diagram below is a pictorial representation of the process outlined in this TSI for the preparation and updating of rules documentation required by this TSI

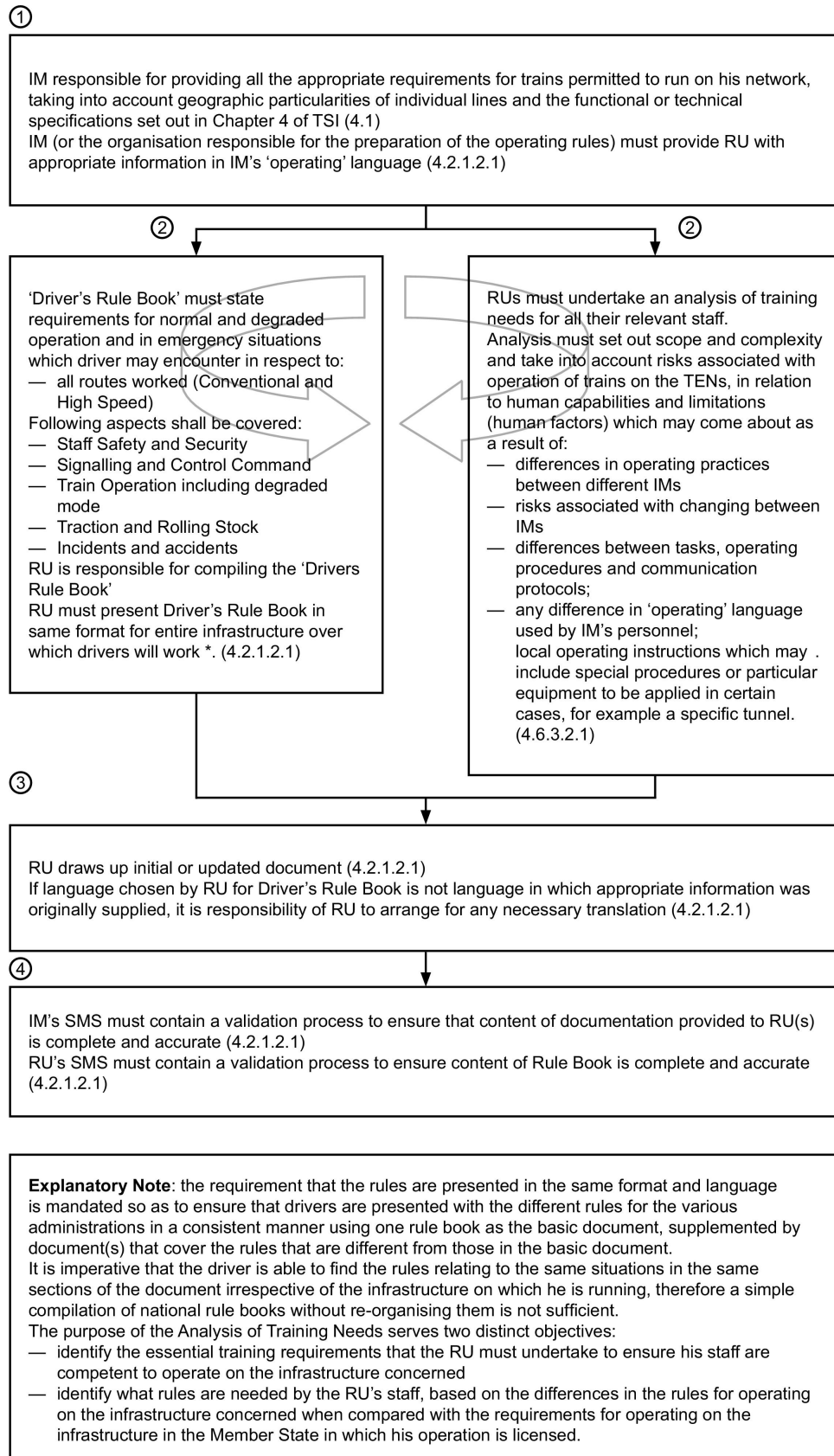

GLOSSARY

Term	Definition
Accident	As defined in Article 3 of Directive 2004/49/EC.
Authorising the movement of trains	The operation of equipment in signalling centres, electric traction current supply control rooms and traffic control centres that permits train movement. This does not include those staff employed by Railway Undertakings who are responsible for management of resources such as train crew or rolling stock.
Dangerous goods	As defined by Article 2 of Directive 96/49
Degraded operation	Operation resulting from an unplanned event that prevents the normal delivery of train services.
Despatch	See Train despatch
Driver	A person competent and authorised to drive trains.
Exceptional loads	A load carried on a rail vehicle, for example a container, swap body or other traffic where the rail vehicle size and/or axle loading requires special authority for the movement and/or the application of special conditions of travel for all or part of the journey.
Health and Safety Conditions	In the context of Chapter 4.7 of this TSI, this refers only to the medical and psychological fitness requirements necessary to operate the relevant elements of the subsystem.
Hot axle box	An axle box and bearing that has exceeded its maximum designed operating temperature.
Incident	As defined in Article 3 of Directive 2004/49/EC.
Book of Forms	A book of forms that describes the sequence of action to be taken by the Infrastructure Manager's staff and the Railway Undertaking's staff when moving trains in degraded situations. Each separate activity requires a separate form. The Book of Forms is prepared in the languages of both the Infrastructure Manager and the Railway Undertaking and the relevant Infrastructure Managers and Railway Undertakings staff holds copies.
Member State	When used in connection with this TSI it refers to the Member State which issues the safety authorisation/certificate as set out in Articles 10 and 11 of Directive 2004/49/EC.
Operating Language	The language or languages used in daily operation by an Infrastructure Manager and published in his Network Statement, for the communication of operational or safety related messages between the staff of the Infrastructure Manager and Railway Undertakings.
Passenger	Person (other than an employee with specific duties on the train) travelling by train or on railway property before or after a train journey.
Performance monitoring	The systematic observation and recording of the performance of the train service and the infrastructure for the purpose of bringing about improvements in the performance of both.
Real time	The ability to exchange or process information on specified events (such as arrival at a station, passing a station or departure from a station) on the trains journey as they occur.
Reporting point	A point on the trains schedule where reporting of the arrival, departure or passing time is required.
Route	The particular section or sections of line
Route knowledge	The knowledge of the section(s) of line over which on board staff operate, based on information provided by the Infrastructure Manager, to enable them to operate the train safely. Essential elements of this knowledge must be learned in detail and remembered by the staff concerned. Other elements may be held in documentation, which those staff can rapidly access based on an assessment of the route by the Railway Undertaking or by the requirements of the National Safety Authority.
Safety critical work	Work performed by staff when they control or affect the movement of a vehicle, which could affect the health, and safety of persons.

Term	Definition
SPAD	A Signal Passed At Danger without authority — that is, a signal showing a stop aspect which is passed without the authority of the person responsible for authorising train movements.
Staff	Employees working for a Railway Undertaking or an Infrastructure Manager, or their contractors, undertaking tasks as specified in this TSI.
Stopping point	A location identified in the schedule of a train where the train is planned to stop, usually to carry out a specific activity such as allowing passengers to join and leave the train.
Timetable	Document or system that gives details of a train(s) schedule over a particular route.
Timing point	A location identified in the schedule of a train where a specific time is identified. This time may be an arrival time, departure time or in the case of a train not scheduled to stop at that location the passing time.
Traction unit	A powered vehicle able to move itself and other vehicles to which it may be coupled.
Train	A train is defined as (a) traction unit(s) with or without coupled railway vehicles, or a self-propelled set of vehicles, with train data available operating between two or more defined points on the TENS.
Train despatch	The indication to the person driving the train that all station or depot activities are completed and that, as far as the staff responsible are concerned, movement authority has been granted for the train.
Train crew	Members of the on-board staff of a train, who are certified as competent and appointed by a Railway Undertaking to carry out specific, designated safety related tasks on the train, for example the driver or the guard.
Train identification	The means to unambiguously identify a particular train.
Train preparation	Ensuring that a train is in a fit condition to enter service, that the train equipment is correctly deployed and the formation of the train matches the train's designated pathway. Train preparation also includes technical inspections carried out prior to the train entering service.
Vehicle	Any single item of rolling stock, for example a locomotive, carriage or wagon.
Vehicle identification	A number applied to a vehicle to uniquely identify it from any other vehicles

LIST OF ABBREVIATIONS TO BE INCLUDED IN THE TSI:

Abbreviation	Explanation
ac	Alternating current
CCS	Command Control Signalling
cen	European Committee for Standardisation (<i>Comité Européen de Normalisation</i>)
COTIF	Convention Concerning International Carriage by Rail
cr	Conventional Rail
Db	Decibels
dc	Direct Current
dmi	Driver Machine Interface
EC	European Community
ECG	Electro Cardiogram
eirene	European Integrated Railway Radio Enhanced Network
en	Euro-norm
ENE	Energy
era	European Railway Agency
ertms	European Rail Traffic Management System
ETCS	European Train Control System
EU	European Union
FRS	Functional Requirement Specification
GSM-R	Global System for Mobile Communications — Rail
habd	Hot Axle Box Detector
Hz	Hertz
IM	Infrastructure Manager
INS	Infrastructure
OPE	Traffic Operation and Management
osjd	Organisation for Co-operation of Railways
PPW	Russian abbreviation for <i>Prawila Polzowaniiia Wagonami w mejdunarodnom soobqenii</i> = Rules for use of railway vehicles in international traffic
RIC	Regulations governing the reciprocal use of carriages and brake vans in international traffic (<i>Règlement pour l'emploi réciproque des Voitures et des Fourgons en Trafic international</i>)
riv	Regulations governing the reciprocal use of wagons in international traffic. (<i>Règlement pour l'emploi réciproque des Wagons en Trafic international</i>)
RST	Rolling Stock
RU	Railway Undertaking
SMS	Safety Management System
spad	Signal Passed at Danger
SRS	System Requirement Specification
TAP	Telematic Applications — Passenger
ten	Trans-European Network
TSI	Technical Specification for Interoperability
uic	International Union of Railways (<i>Union Internationale des Chemins de fer</i>)
UV	Ultra violet
VKM	Vehicle Keeper Marking

COMMISSION DECISION

of 21 February 2008

concerning a technical specification for interoperability relating to the 'rolling stock' sub-system of the trans-European high-speed rail system*(notified under document number C(2008) 648)***(Text with EEA relevance)**

(2008/232/CE)

THE COMMISSION OF THE EUROPEAN COMMUNITIES,

Having regard to the Treaty establishing the European Community,

Having regard to Directive 96/48/EC of 23 July 1996 of the Council on the interoperability of the trans-European high speed rail system ⁽¹⁾, and in particular Article 6 (1) thereof,

Whereas:

- (1) In accordance with Article 2(c) and Annex II of Directive 96/48/EC, the trans-European high speed rail system is subdivided into structural and functional subsystems, including a rolling stock subsystem.
- (2) Commission Decision 2002/735/EC ⁽²⁾ established the first technical specification for interoperability (TSI) concerning the trans-European high speed rolling stock sub-system.
- (3) It is necessary to review that first TSI in light of technical progress and experience gained from its implementation.
- (4) The AEIF, as joint representative body, had been given a mandate to review and revise that first TSI. Decision 2002/735/EC should therefore be replaced by this Decision.
- (5) The draft revised TSI has been examined by the Committee set up by Directive 96/48/EC
- (6) This TSI should apply to new or upgraded and renewed rolling stock, under certain conditions.
- (7) This TSI is without prejudice to the provisions of other relevant TSIs which may be applicable to rolling stock subsystems.

- (8) The first TSI concerning the 'rolling stock' sub-system, came into force in 2002. Due to existing contractual commitments, new rolling stock sub-systems or interoperability constituents, or their renewal and upgrade should fall under conformity assessment under the provisions of this first TSI. Further, the first TSI should remain applicable for the purposes of maintenance, maintenance related replacements for components of the subsystem and interoperability constituents authorised under the first TSI. Therefore, the effects of Decision 2002/735/EC should be maintained in force in relation to the maintenance of projects authorised in accordance with the TSI annexed to that Decision and to projects for a new line and for the renewal or upgrading of an existing line which are at an advanced stage of development or the subject of a contract in course of performance at the date of notification of the present Decision. In order to determine the difference in scope of applicability of the first TSI, from the new TSI which is in annex to the present Decision, Member States shall notify, not later than six months after the date on which the present Decision becomes applicable, a list of the sub-systems and interoperability constituents to which the first TSI is still applicable.
- (9) This TSI does not impose the use of specific technologies or technical solutions except where this is strictly necessary for the interoperability of the trans-European high speed rail system.
- (10) This TSI allows, for a limited period of time, for interoperability constituents to be incorporated into sub-systems without certification if certain conditions are met.
- (11) In its current version this TSI does not fully deal with all essential requirements. In accordance with Article 17 of Directive 96/48/EC technical aspects which are not covered are identified as 'Open Points' in Annex L of this TSI. In accordance with Article 16(3) of Directive 96/48/EC, Member States shall notify to the Commission and other Member States a list of their national technical rules relating to the 'Open Points' and the procedures to be used for their conformity assessment.
- (12) In relation to the specific cases described in Chapter 7 of this TSI, Member States shall notify to the Commission and other Member States the conformity assessment procedures to be used.

⁽¹⁾ OJ L 235, 17.9.1996, p. 6, Directive as amended by Directive 2004/50/EC (OJ L 164, 30.4.2004, p. 114).

⁽²⁾ OJ L 245, 12.9.2002, p. 402

- (13) Rail traffic currently operates under existing national, bilateral, multinational or international agreements. It is important that those agreements do not hinder current and future progress towards interoperability. To this end, it is necessary that the Commission examine those agreements in order to determine whether the TSI presented in this Decision needs to be revised accordingly.
- (14) The TSI is based on best available expert knowledge at the time of preparation of the relevant draft. To continue to encourage innovation and to take into account the experience acquired, the attached TSI should be subject to periodic revision.
- (15) This TSI allows for innovative solutions. Where these are proposed the manufacturer or the contracting entity shall state the deviation from the relevant section of the TSI. The European Rail Agency will finalise the appropriate functional and interface specifications of the solution and develop the assessment methods.
- (16) The provisions of this Decision are in conformity with the opinion of the Committee set up by Article 21 of Council Directive 96/48/EC,

HAS ADOPTED THIS DECISION:

Article 1

A Technical Specification for Interoperability (‘TSI’) relating to the ‘rolling stock’ subsystem of the trans-European high speed railway, is hereby adopted by the Commission.

The TSI shall be as set out in the Annex to this Decision.

Article 2

This TSI shall be applicable to all new, upgraded or renewed rolling stock of the trans-European high speed rail system as defined in Annex I to Directive 96/48/EC.

Article 3

(1) With regard to those issues classified as ‘Open points’ set out in Annex L of the TSI, the conditions to be complied with for the verification of the interoperability pursuant to Article 16(2) of Directive 96/48/EC shall be those applicable technical rules in use in the Member State which authorise the placing in service of the subsystems covered by this Decision.

(2) Each Member State shall notify to the other Member States and to the Commission within six months of the notification of this Decision:

- (a) the list of the technical rules mentioned in paragraph 1;
- (b) the conformity assessment and checking procedures to be applied with regard to the application of these rules;
- (c) the bodies it appoints for carrying out those conformity-assessment and checking procedures.

Article 4

With regard to those issues classified as ‘Specific Cases’ set out in Chapter 7 of the TSI the conformity assessment procedures shall be those applicable in Member States. Each Member State shall notify to the other Member States and the Commission within six months of the notification of this Decision:

- (a) the conformity assessment and checking procedures to be applied with regard to the application of these rules;
- (b) the bodies it appoints for carrying out those conformity-assessment and checking procedures.

Article 5

The TSI allows for a transition period during which the conformity assessment and certification of interoperability constituents may be carried out as part of the sub-system. During this time Member States shall notify to the Commission which interoperability constituents have been assessed in this manner in order for the market for interoperability constituents to be closely monitored and steps taken to facilitate it.

Article 6

Decision 2002/735/EC is hereby repealed. Its provisions shall however continue to apply in relation to the maintenance of projects authorised in accordance with the TSI annexed to that Decision and to projects for a new line and for the renewal or upgrading of an existing line which are at an advanced stage of development or the subject of a contract in course of performance at the date of notification of the present Decision.

A list of the sub-systems and interoperability constituents to which the provisions of Decision 2002/735/EC continue to apply shall be notified to the Commission not later than six months after the date on which the present Decision becomes applicable.

Article 7

Member States shall notify the following types of agreement to the Commission within six months of the entry into force of the attached TSI:

- (a) national, bilateral or multilateral agreements between Member States and Railway Undertaking(s) or Infrastructure Manager(s), agreed on either a permanent or a temporary basis and required due to the very specific or local nature of the intended train service;
- (b) bilateral or multilateral agreements between Railway Undertaking(s), Infrastructure Manager(s) or Member State(s) which deliver significant levels of local or regional interoperability;

- (c) international agreements between one or more Member State(s) and at least one third country, or between Railway Undertaking(s) or Infrastructure Manager(s) of Member States and at least one Railway Undertaking or Infrastructure Manager of a third country, which deliver significant levels of local or regional interoperability.

Article 8

This Decision shall apply from 1 September 2008.

Article 9

This Decision is addressed to the Member States.

Done at Brussels, 21 February 2008.

For the Commission
Jacques BARROT
Vice-President of the Commission

ANNEX

DIRECTIVE 96/48/EC — INTEROPERABILITY OF THE TRANS-EUROPEAN HIGH SPEED RAIL SYSTEM

TECHNICAL SPECIFICATION FOR INTEROPERABILITY

'Rolling stock' Sub-System

1.	INTRODUCTION	146
1.1.	Technical scope	146
1.2.	Geographical scope	146
1.3.	Content of this TSI	146
2.	DEFINITION AND FUNCTIONS OF THE ROLLING STOCK SUBSYSTEM	147
2.1.	Subsystem Description	147
2.2.	Functions and aspects of the rolling stock subsystem	147
3.	ESSENTIAL REQUIREMENTS	147
3.1.	General	147
3.2.	The essential requirements relate to	148
3.3.	General requirements	148
3.3.1.	Safety	148
3.3.2.	Reliability and availability	150
3.3.3.	Health requirements	151
3.3.4.	Protection of the environment	151
3.3.5.	Technical compatibility	152
3.4.	Requirements specific to the rolling stock subsystem	153
3.4.1.	Safety	153
3.4.2.	Reliability and availability	154
3.4.3.	Technical compatibility	155
3.5.	Requirements specific to maintenance	156
3.6.	Other requirements also concerning the rolling stock subsystem	157
3.6.1.	Infrastructure	157
3.6.2.	Energy	157
3.6.3.	Control-command and signalling	158
3.6.4.	Environment	158
3.6.5.	Operation	159
3.7.	Elements of the rolling stock subsystem related to the essential requirements	160
4.	CHARACTERISTICS OF THE SUBSYSTEM	162
4.1.	Introduction	162
4.2.	Functional and technical specification of the subsystem	163
4.2.1.	General	163
4.2.1.1.	Introduction	163
4.2.1.2.	Design of trains	164

4.2.2.	Structure and mechanical parts	165
4.2.2.1.	General	165
4.2.2.2.	End couplers and coupling arrangements to rescue trains	166
4.2.2.2.1.	Subsystem requirements	166
4.2.2.2.2.	Interoperability constituent requirements	166
4.2.2.2.2.1.	Automatic centre buffer coupler	166
4.2.2.2.2.2.	Buffing and draw gear components	166
4.2.2.2.2.3.	Towing coupler for recovery and rescue	166
4.2.2.3.	Strength of vehicle structure	166
4.2.2.3.1.	General description	166
4.2.2.3.2.	Principles (functional requirements)	167
4.2.2.3.3.	Specifications (simple load cases and design collision scenarios)	167
4.2.2.4.	Access	167
4.2.2.4.1.	Passenger step	167
4.2.2.4.2.	External access door	168
4.2.2.4.2.1.	Passenger access doors	168
4.2.2.4.2.2.	Doors for freight use and for use of the train crew	169
4.2.2.5.	Toilets	169
4.2.2.6.	Driver's cab	169
4.2.2.7.	Windscreen and front of the train	170
4.2.2.8.	Storage facilities for use by staff	170
4.2.2.9.	External steps for use by shunting staff	171
4.2.3.	Track interaction and gauging	171
4.2.3.1.	Kinematic gauge	171
4.2.3.2.	Static axle load	171
4.2.3.3.	Rolling stock parameters which influence ground based train monitoring systems	172
4.2.3.3.1.	Electrical resistance	172
4.2.3.3.2.	Axle bearing health monitoring	172
4.2.3.3.2.1.	Class 1 trains	172
4.2.3.3.2.2.	Class 2 trains	173
4.2.3.3.2.3.	Hot axle box detection for Class 2 trains	173
4.2.3.3.2.3.1.	General	173
4.2.3.3.2.3.2.	Functional requirements for the vehicle	173
4.2.3.3.2.3.3.	Transverse dimensions and height above rail level of the target area	173
4.2.3.3.2.3.4.	Longitudinal dimension of the target area	173
4.2.3.3.2.3.5.	Limit criteria outside of the target area	174
4.2.3.3.2.3.6.	Emissivity	174
4.2.3.4.	Rolling stock dynamic behaviour	175
4.2.3.4.1.	General	175

4.2.3.4.2.	Limit values for running safety	176
4.2.3.4.3.	Track loading limit values	177
4.2.3.4.4.	Wheel/rail interface	178
4.2.3.4.5.	Design for vehicle stability	178
4.2.3.4.6.	Definition of equivalent conicity	178
4.2.3.4.7.	Design values for wheel profiles	179
4.2.3.4.8.	In service values of equivalent conicity	179
4.2.3.4.9.	Wheelsets	180
4.2.3.4.9.1.	Wheelsets	180
4.2.3.4.9.2.	Interoperability Constituent Wheels	180
4.2.3.4.10.	Specific requirements for vehicles with independently rotating wheels	181
4.2.3.4.11.	Detection of derailments	181
4.2.3.5.	Maximum train length	181
4.2.3.6.	Maximum gradients	181
4.2.3.7.	Minimum curve radius	182
4.2.3.8.	Flange lubrication	182
4.2.3.9.	Suspension coefficient	182
4.2.3.10.	Sanding	182
4.2.3.11.	Ballast pick up	182
4.2.4.	Braking	182
4.2.4.1.	Minimum braking performance	182
4.2.4.2.	Brake wheel/rail adhesion demand limits	184
4.2.4.3.	Brake system requirements	185
4.2.4.4.	Service braking performance	186
4.2.4.5.	Eddy current brakes	186
4.2.4.6.	Protection of an immobilised train	187
4.2.4.7.	Brake performance on steep gradients	187
4.2.4.8.	Brake requirements for rescue purposes	187
4.2.5.	Passenger information and communication	188
4.2.5.1.	Public address system	188
4.2.5.2.	Passenger information signs	188
4.2.5.3.	Passenger alarm	188
4.2.6.	Environmental conditions	189
4.2.6.1.	Environmental conditions	189
4.2.6.2.	Train aerodynamic loads in open air	189
4.2.6.2.1.	Aerodynamic loads on track workers at the lineside	189
4.2.6.2.2.	Aerodynamic loads on passengers on a platform	190
4.2.6.2.3.	Pressure loads in open air	192
4.2.6.3.	Crosswind	193

4.2.6.4.	Maximum pressure variations in tunnels	195
4.2.6.5.	Exterior noise	196
4.2.6.5.1.	Introduction	196
4.2.6.5.2.	Limits for stationary noise	197
4.2.6.5.3.	Limits for starting noise	197
4.2.6.5.4.	Limits for pass-by noise	198
4.2.6.6.	Exterior electromagnetic interference	198
4.2.6.6.1.	Interference generated on the signalling system and the telecommunications network:	198
4.2.6.6.2.	Electromagnetic interference:	198
4.2.7.	System protection	199
4.2.7.1.	Emergency exits	199
4.2.7.1.1.	Passengers' emergency exits	199
4.2.7.1.2.	Driver's cab emergency exits	199
4.2.7.2.	Fire safety	199
4.2.7.2.1.	Introduction	200
4.2.7.2.2.	Measures to prevent fire	200
4.2.7.2.3.	Measures to detect/control fire	200
4.2.7.2.3.1.	Fire detection	200
4.2.7.2.3.2.	Fire extinguisher	201
4.2.7.2.3.3.	Fire resistance	201
4.2.7.2.4.	Additional measures to improve running capability	201
4.2.7.2.4.1.	Trains of all categories of fire safety	201
4.2.7.2.4.2.	Category B fire safety	202
4.2.7.2.5.	Specific measures for tanks containing flammable liquids	202
4.2.7.2.5.1.	General	202
4.2.7.2.5.2.	Specific requirements for fuel tanks	203
4.2.7.3.	Protection against electric shock	204
4.2.7.4.	External lights and horn	204
4.2.7.4.1.	Front and rear lights	204
4.2.7.4.1.1.	Head lights	204
4.2.7.4.1.2.	Marker lights	204
4.2.7.4.1.3.	Tail lights	205
4.2.7.4.1.4.	Lamp controls	205
4.2.7.4.2.	Horns	205
4.2.7.4.2.1.	General	205
4.2.7.4.2.2.	Warning horn sound pressure levels	206
4.2.7.4.2.3.	Protection	206
4.2.7.4.2.4.	Verification of sound pressure levels	206
4.2.7.4.2.5.	Interoperability constituent requirements	207

4.2.7.5.	Lifting/rescue procedures	207
4.2.7.6.	Interior noise	207
4.2.7.7.	Air conditioning	208
4.2.7.8.	Driver's vigilance device	208
4.2.7.9.	Control-command and signalling system	208
4.2.7.9.1.	General	208
4.2.7.9.2.	Wheelset location	209
4.2.7.9.3.	Wheels	209
4.2.7.10.	Monitoring and diagnostic concepts	209
4.2.7.11.	Particular specification for tunnels	210
4.2.7.11.1.	Passenger and train crew areas equipped with air conditioning	210
4.2.7.11.2.	Public address system	210
4.2.7.12.	Emergency lighting system	210
4.2.7.13.	Software	210
4.2.7.14.	Driver-Machine-Interface (DMI)	210
4.2.7.15.	Vehicle identification	210
4.2.8.	Traction and electrical equipment	210
4.2.8.1.	Traction performance requirements	210
4.2.8.2.	Traction wheel/rail adhesion requirements	211
4.2.8.3.	Functional and technical specification related to the electric power supply	211
4.2.8.3.1.	Voltage and frequency of the power supply	212
4.2.8.3.1.1.	Power supply	212
4.2.8.3.1.2.	Energy recuperation	212
4.2.8.3.2.	Maximum power and maximum current that is permissible to draw from the overhead contact line	212
4.2.8.3.3.	Power factor	212
4.2.8.3.4.	System energy disturbances	212
4.2.8.3.4.1.	Harmonic characteristics and related over-voltages on the overhead contact line	212
4.2.8.3.4.2.	Effects of DC content in AC supply	212
4.2.8.3.5.	Energy consumption measuring devices	212
4.2.8.3.6.	Rolling stock subsystem requirements linked to pantographs	213
4.2.8.3.6.1.	Pantograph contact force	213
4.2.8.3.6.2.	Arrangement of pantographs	214
4.2.8.3.6.3.	Insulation of pantograph from the vehicle	214
4.2.8.3.6.4.	Pantograph lowering	215
4.2.8.3.6.5.	Quality of current collection	215
4.2.8.3.6.6.	Electrical protection coordination	215
4.2.8.3.6.7.	Running through phase separation sections	215
4.2.8.3.6.8.	Running through system separation sections	215
4.2.8.3.6.9.	Height of pantographs	216

4.2.8.3.7.	Interoperability constituent pantograph	216
4.2.8.3.7.1.	Overall design	216
4.2.8.3.7.2.	Pantograph head geometry	216
4.2.8.3.7.3.	Pantograph static contact force	217
4.2.8.3.7.4.	Working range of pantographs	217
4.2.8.3.7.5.	Current capacity	217
4.2.8.3.8.	Interoperability constituent contact strip	217
4.2.8.3.8.1.	General	217
4.2.8.3.8.2.	Contact strip geometry	217
4.2.8.3.8.3.	Material	217
4.2.8.3.8.4.	Detection of contact strip breakage	217
4.2.8.3.8.5.	Current capacity	218
4.2.8.3.9.	Interfaces with electrification system	218
4.2.8.3.10.	Interfaces with control-command and signalling subsystem	218
4.2.9.	Servicing	219
4.2.9.1.	General	219
4.2.9.2.	Train external cleaning facilities	219
4.2.9.3.	Toilet discharge system	219
4.2.9.3.1.	On board discharge system	219
4.2.9.3.2.	Mobile discharge trolleys	219
4.2.9.4.	Train interior cleaning	220
4.2.9.4.1.	General	220
4.2.9.4.2.	Electrical sockets	220
4.2.9.5.	Water restocking equipment	220
4.2.9.5.1.	General	220
4.2.9.5.2.	Water filling adapter	220
4.2.9.6.	Sand restocking equipment	220
4.2.9.7.	Special requirements for stabling of trains	221
4.2.9.8.	Refuelling equipment	221
4.2.10.	Maintenance	221
4.2.10.1.	Responsibilities	221
4.2.10.2.	The maintenance file	221
4.2.10.2.1.	The maintenance design justification file	221
4.2.10.2.2.	The Maintenance Documentation	222
4.2.10.3.	Management of the maintenance file	223
4.2.10.4.	Management of maintenance information	224
4.2.10.5.	Implementation of the maintenance	225
4.3.	Functional and technical specification of the interfaces	225
4.3.1.	General	225
4.3.2.	Infrastructure subsystem	228

4.3.2.1.	Access	228
4.3.2.2.	Driver's cab	228
4.3.2.3.	Kinematic gauge	229
4.3.2.4.	Static axle load	229
4.3.2.5.	Rolling stock parameters, which influence ground based train monitoring systems	229
4.3.2.6.	Rolling stock dynamic behaviour and wheel profiles	229
4.3.2.7.	Maximum train length	229
4.3.2.8.	Maximum gradients	229
4.3.2.9.	Minimum curve radius	229
4.3.2.10.	Flange lubrication	229
4.3.2.11.	Ballast pick up	229
4.3.2.12.	Eddy current brake	229
4.3.2.13.	Brake performance on steep gradients	230
4.3.2.14.	Passenger alarm	230
4.3.2.15.	Environmental conditions	230
4.3.2.16.	Train aerodynamic loads in open air	230
4.3.2.17.	Crosswind	230
4.3.2.18.	Maximum pressure variations in tunnels	230
4.3.2.19.	Exterior noise	230
4.3.2.20.	Fire safety	230
4.3.2.21.	Head lights	230
4.3.2.22.	Particular specification for tunnels	230
4.3.2.23.	Servicing	231
4.3.2.24.	Maintenance	231
4.3.3.	Energy subsystem	231
4.3.3.1.	Reserved	231
4.3.3.2.	Brake system requirements	231
4.3.3.3.	Exterior electromagnetic interference	231
4.3.3.4.	Head lights	231
4.3.3.5.	Functional and technical specification related to power supply	231
4.3.4.	Control-Command and Signalling Subsystem	231
4.3.4.1.	Driver's cab	231
4.3.4.2.	Windscreen and front of the train	231
4.3.4.3.	Static axle load	232
4.3.4.4.	Rolling stock parameters, which influence ground based train monitoring systems	232
4.3.4.5.	Sanding	232
4.3.4.6.	Braking performance	232
4.3.4.7.	Electromagnetic interference	232
4.3.4.8.	Control-command and signalling system	232
4.3.4.9.	Monitoring and diagnostic concepts	233

4.3.4.10.	Particular specification for tunnels	234
4.3.4.11.	Functional and technical specification related to power supply	234
4.3.4.12.	Vehicle front lights	234
4.3.5.	Operation subsystem	234
4.3.5.1.	Design of the trains	234
4.3.5.2.	End couplers and coupling arrangements to rescue trains	234
4.3.5.3.	Access	234
4.3.5.4.	Toilets	234
4.3.5.5.	Windscreen and front of the train	234
4.3.5.6.	Rolling stock parameters, which influence ground based train monitoring systems	234
4.3.5.7.	Rolling stock dynamic behaviour	234
4.3.5.8.	Maximum train length	234
4.3.5.9.	Sanding	234
4.3.5.10.	Ballast pick up	234
4.3.5.11.	Braking performance	234
4.3.5.12.	Brake system requirements	234
4.3.5.13.	Eddy current brakes	234
4.3.5.14.	Protection of an immobilised train	235
4.3.5.15.	Brake performance on steep gradients	235
4.3.5.16.	Public address system	235
4.3.5.17.	Passenger alarm	235
4.3.5.18.	Environmental conditions	235
4.3.5.19.	Train aerodynamic loads in open air	235
4.3.5.20.	Crosswind	235
4.3.5.21.	Maximum pressure variations in tunnels	235
4.3.5.22.	Exterior noise	235
4.3.5.23.	Emergency exits	236
4.3.5.24.	Fire safety	236
4.3.5.25.	External lights and horn	236
4.3.5.26.	Lifting/rescue procedures	236
4.3.5.27.	Interior noise	236
4.3.5.28.	Air conditioning	236
4.3.5.29.	Driver's vigilance device	236
4.3.5.30.	Monitoring and diagnostic concepts	236
4.3.5.31.	Particular specification for tunnels	236
4.3.5.32.	Traction performance requirements	236
4.3.5.33.	Traction wheel/rail adhesion requirements	236
4.3.5.34.	Functional and technical specification related to power supply	237
4.3.5.35.	Servicing	237
4.3.5.36.	Vehicle identification	237

4.3.5.37.	Signal sighting	237
4.3.5.38.	Emergency exits	237
4.3.5.39.	Driver-Machine-Interface (DMI)	237
4.4.	Operating rules	237
4.5.	Maintenance rules	238
4.6.	Professional competencies	238
4.7.	Health and safety conditions	238
4.8.	Infrastructure and rolling stock registers	239
4.8.1.	Infrastructure register	239
4.8.2.	Rolling stock register	240
5.	INTEROPERABILITY CONSTITUENTS	240
5.1.	Definition	240
5.2.	Innovative solutions	240
5.3.	List of constituents	240
5.4.	Constituents performance and specifications	241
6.	ASSESSMENT OF CONFORMITY AND/OR SUITABILITY FOR USE	241
6.1.	Interoperability constituents of the rolling stock subsystem	241
6.1.1.	Conformity assessment (general)	241
6.1.2.	Conformity assessment procedures (modules)	242
6.1.3.	Existing solutions	243
6.1.4.	Innovative solutions	243
6.1.5.	Assessment of suitability for use	243
6.2.	Rolling stock subsystem	244
6.2.1.	Conformity assessment (general)	244
6.2.2.	Conformity assessment procedures (modules)	244
6.2.3.	Innovative solutions	245
6.2.4.	Assessment of maintenance	245
6.2.5.	Assessment of single vehicles	245
6.3.	Interoperable Constituents Not Holding an EC Declaration	245
6.3.1.	General	245
6.3.2.	The Transition Period	245
6.3.3.	The Certification of Subsystems Containing Non-Certified Interoperability Constituents during the Transition Period	246
6.3.3.1.	Conditions	246
6.3.3.2.	Notification	246
6.3.3.3.	Lifecycle Implementation	246
6.3.4.	Monitoring Arrangements	247
7.	IMPLEMENTATION OF THE ROLLING STOCK TSI	247
7.1.	Implementation of the TSI	247
7.1.1.	Newly built rolling stock of new design	247

7.1.1.1.	Definitions	247
7.1.1.2.	General	247
7.1.1.3.	Phase A	247
7.1.1.4.	Phase B	248
7.1.2.	Newly built rolling stock of an existing design certified to an existing TSI	248
7.1.3.	Rolling stock of an existing design	249
7.1.4.	Rolling stock being upgraded or renewed	249
7.1.5.	Noise	250
7.1.5.1.	Transitional period	250
7.1.5.2.	Upgrading or renewal of rolling stock	250
7.1.5.3.	A two step approach	250
7.1.6.	Mobile toilet discharge trolleys [clause 4.2.9.3]	250
7.1.7.	Measures to prevent fire — material conformity	250
7.1.8.	Rolling stock operating under national, bilateral, multilateral or international agreements	251
7.1.8.1.	Existing agreements	251
7.1.8.2.	Future agreements	251
7.1.9.	TSI revision	251
7.2.	Compatibility of rolling stock with other subsystems	251
7.3.	Specific cases	252
7.3.1.	General	252
7.3.2.	List of specific cases	252
7.3.2.1.	General specific case on the 1 524 mm gauge network	252
7.3.2.2.	End couplers and coupling arrangements to rescue trains [clause 4.2.2.2]	252
7.3.2.3.	Passenger step [clause 4.2.2.4.1]	252
7.3.2.4.	Vehicle gauge [clause 4.2.3.1]	253
7.3.2.5.	Vehicle mass [clause 4.2.3.2]	253
7.3.2.6.	Electrical resistance of wheelsets [clause 4.2.3.3.1]	253
7.3.2.7.	Hot axle box detection for Class 2 trains [clause 4.2.3.3.2.3]	254
7.3.2.8.	Wheel-rail contact (wheel profiles) [4.2.3.4.4]	255
7.3.2.9.	Wheelsets [4.2.3.4.9]	255
7.3.2.10.	Maximum train length [4.2.3.5]	255
7.3.2.11.	Sanding [4.2.3.10]	255
7.3.2.12.	Braking [clause 4.2.4]	256
7.3.2.12.1.	General	256
7.3.2.12.2.	Eddy current brakes [clause 4.2.4.5]	256
7.3.2.13.	Environmental conditions [clause 4.2.6.1]	256
7.3.2.14.	Train Aerodynamics	256
7.3.2.14.1.	Aerodynamic loads on passengers on a platform [clause 4.2.6.2.2]	256
7.3.2.14.2.	Pressure loads in open air [clause 4.2.6.2.3]	257

7.3.2.14.3.	Maximum pressure variations in tunnels [clause 4.2.6.4]	257
7.3.2.15.	Boundary characteristics linked to exterior noise [clause 4.2.6.5]	257
7.3.2.15.1.	Limit for stationary noise [clause 4.2.6.5.2]	257
7.3.2.15.2.	Limit for starting noise [clause 4.2.6.5.3]	258
7.3.2.16.	Fire extinguisher [clause 4.2.7.2.3.2]	258
7.3.2.17.	Horns [clause 4.2.7.4.2.1]	258
7.3.2.18.	Control-command and signalling system [clause 4.2.7.10]	258
7.3.2.18.1.	Wheelset location [clause 4.2.7.10.2]	258
7.3.2.18.2.	Wheels [clause 4.2.7.10.3]	259
7.3.2.19.	Pantograph [clause 4.2.8.3.6.]	260
7.3.2.20.	Interfaces with control-command and signalling system [clause 4.2.8.3.8]	263
7.3.2.21.	Toilet discharge system connections [clause 4.2.9.3.]	263
7.3.2.22.	Water filling adapters [clause 4.2.9.5.]	263
7.3.2.23.	Fire Standards [clause 7.1.6]	263

1. INTRODUCTION

1.1. Technical scope

This TSI concerns the rolling stock subsystem. These subsystems are included in the list of Annex II(1) to Directive 96/48/EC, as modified by Directive 2004/50/EC.

This TSI is applicable to the following classes of rolling stock, assessed as trainsets (indivisible in service), or as single vehicles, within defined formations of powered and non-powered vehicles. It applies equally to passenger and/or non-passenger carrying vehicles.

Class 1: Rolling stock having a maximum speed equal to or greater than 250 km/h.

Class 2: Rolling stock having a maximum speed of at least 190 km/h but less than 250 km/h.

This TSI shall be applied for rolling stock, referred in section 2 of annex I of Directive 96/48/EC as modified by Dir.2004/50/EC and having a maximum speed of at least 190 km/h as described above. But, if the maximum speed of this rolling stock is higher than 351 km/h, this TSI will apply, but additional specifications are necessary: these additional specifications are not detailed in this TSI and are an open point: national rules apply in such a case.

More information about the rolling stock subsystem is given in section 2.

This TSI specifies requirements with which rolling stock intended to be operated on the rail network as defined in section 1.2 below shall comply and thereby meet the essential requirements of Directive 96/48/EC, as modified by Directive 2004/50/EC.

Access to lines is not solely dependent on fulfilment of the technical requirements of this TSI, other requirements in Directive 2004/49 and Directive 2001/14, as modified by Directive 2004/50 shall also be taken into account in permitting a railway undertaking to operate this rolling stock on a specific line. For example an infrastructure manager is permitted to decide not to allocate a path for a class 2 train on a category 1 line for capacity reasons.

1.2. Geographical scope

The geographical scope of this TSI is the trans-European high-speed rail system as described in Annex I to Directive 96/48/EC modified by Directive 2004/50/EC.

1.3. Content of this TSI

In accordance with Article 5(3) and with Annex I, (1)b of Directive 96/48/EC modified by Directive 2004/50/EC, this TSI:

- (a) indicates its intended scope (section 2);
- (b) states essential requirements for the rolling stock subsystem (section 3)
- (c) establishes the functional and technical specifications to be met by the subsystems and their interfaces with other subsystems (section 4);
- (d) sets out, operating and maintenance rules specific to the scope indicated in sections 1.1 and 1.2 above (section 4).
- (e) indicates, for the persons concerned, the professional competencies and health and safety conditions at work required for the operation and maintenance of the subsystems (section 4).
- (f) determines the interoperability constituents and interfaces which are to be covered by European specifications, including European standards, which are necessary to achieve interoperability within the trans-European high-speed rail system (section 5);

- (g) states which procedures are to be used in order to assess the conformity or the suitability for use of the interoperability constituents, on the one hand, or the EC verification of the subsystems, on the other hand (section 6);
- (h) indicates the strategy for implementing the TSIs (section 7);
- (i) makes provision, in accordance with Article 6(3) of the Directive, specific cases (section 7).

2. DEFINITION AND FUNCTIONS OF THE ROLLING STOCK SUBSYSTEM

2.1. Subsystem Description

The rolling stock subsystem includes neither the control-command, infrastructure, operation subsystems nor the trackside part of the energy subsystem, since these subsystems are specified in their own TSIs.

In addition, rolling stock subsystem does not include the train staff (driver and other on-board train crew) and passengers.

2.2. Functions and aspects of the rolling stock subsystem

The scope of this TSI for the rolling stock subsystem is expanded from that given in the TSI contained in Annex to Decision 2002/735/EC.

The functions to be fulfilled in the scope of the rolling stock subsystem are as follows:

- Carry and protect the passengers and train crew
- Accelerate, maintain speed, brake and stop
- Keep the train driver informed, provide a view ahead, and allow proper control
- Support and guide the train on the track
- Signal the presence of the train to others
- Be able to operate safely even in the event of incidents
- Respect the environment
- Maintain the rolling stock subsystem and the on-board part of the energy subsystem
- Be able to operate on relevant traction supply systems.

The on-board control-command and signalling equipment is within the scope of the control-command and signalling subsystem.

3. ESSENTIAL REQUIREMENTS

3.1. General

In the scope of this TSI, fulfilment of relevant essential requirements quoted in section 3 of this TSI will be ensured by the compliance with the specifications described:

- in section 4 for the subsystems,
- and in section 5 for the interoperability constituents,
- as demonstrated by a positive result of the assessment of:

- conformity and/or suitability for use of the interoperability constituents
- and verification of the subsystems.

as described in section 6.

Parts of the essential requirements are covered by national rules because:

- open and reserved points are listed in Annex L;
- derogations under art. 7 of the Directive 96/48/EC;
- specific cases are described in section 7.3 of this TSI.

The corresponding conformity assessment shall be carried out under the responsibility and according to procedures of the Member State that has notified the national rules or asked for the derogation or the specific case.

According to Article 4(1) of Directive 96/48/EC modified by Directive 2004/50/EC, the Trans-European high-speed rail system, subsystems and their interoperability constituents shall meet the essential requirements set out in general terms in Annex III to the Directive.

Conformity of the rolling stock subsystem and its constituents to the essential requirements is checked in accordance with the provisions envisaged in Directive 96/48/EC modified by Directive 2004/50/EC as well as in this TSI.

3.2. **The essential requirements relate to:**

- safety,
- reliability and availability,
- health,
- environmental protection,
- technical compatibility.

According to Directive 96/48/EC modified by Directive 2004/50/EC, the essential requirements can be generally applied to the whole Trans-European high-speed rail system or be specific to particular aspects of each subsystem and its constituents.

3.3. **General requirements**

In the case of the rolling stock subsystem, the specific aspects, in addition to the considerations contained in Annex III to the Directive, are as follows:

3.3.1. Safety

Essential requirement 1.1.1:

The design, construction or assembly, maintenance and monitoring of safety-critical components, and more particularly of the components involved in train movements must be such as to guarantee safety at the level corresponding to the aims laid down for the network, including those for specific degraded situations.'

This essential requirement is satisfied by the functional and technical specifications in clauses:

- 4.2.2.2 (end couplers and coupling arrangements to rescue trains)
- 4.2.2.3 (strength of vehicle structure)
- 4.2.2.4 (access)

- 4.2.2.6 (driver's cab)
- 4.2.2.7 (windscreen and front of the train)
- 4.2.3.1 (kinematic gauge)
- 4.2.3.3 (rolling stock parameters which influence ground based train monitoring systems)
- 4.2.3.4 (rolling stock dynamic behaviour)
- 4.2.3.10 (sanding)
- 4.2.3.11 (aerodynamic effects on ballast)
- 4.2.4 (braking)
- 4.2.5 (passenger information and communication)
- 4.2.6.2 (train aerodynamic loads in open air)
- 4.2.6.3 (crosswind)
- 4.2.6.4 (maximum pressure variations in tunnels)
- 4.2.6.6 (exterior electromagnetic interference)
- 4.2.7 (system protection)
- 4.2.7.13 (software)
- 4.2.10 (maintenance)

Essential requirement 1.1.2:

The parameters involved in the wheel-rail contact must meet the stability requirements needed in order to guarantee safe movement at the maximum authorised speed.'

This essential requirement is satisfied by the functional and technical specifications in clauses:

- 4.2.3.2 (static axle load)
- 4.2.3.4 (rolling stock dynamic behaviour)

Essential requirement 1.1.3:

The components used must withstand any normal or exceptional stresses that have been specified during their period in service. The safety repercussions of any accidental failures must be limited by appropriate means.'

This essential requirement is satisfied by the functional and technical specifications in clauses:

- 4.2.2.2 (end couplers and coupling arrangements to rescue trains)
- 4.2.2.3 (strength of vehicle structure)
- 4.2.2.7 (windscreen and front of the train)
- 4.2.3.3.2 (axle bearing health monitoring)
- 4.2.3.4.3 (track loading limit values)
- 4.2.3.4.9 (wheelsets)
- 4.2.4 (braking)

- 4.2.6 1 (environmental conditions)
- 4.2.6.3 (crosswind)
- 4.2.6.4 (maximum pressure variations in tunnels)
- 4.2.7.2 (fire safety)
- 4.2.8.3.6 (pantographs and contact strips)
- 4.2.9 (servicing)
- 4.2.10 (maintenance)

Essential requirement 1.1.4:

'The design of fixed installation and rolling stock and the choice of the materials used must be aimed at limiting the generation, propagation and effects of fire and smoke fumes in the event of a fire.'

This essential requirement is satisfied by the functional and technical specifications in clauses:

- 4.2.7.2 (fire safety)

Essential requirement 1.1.5:

'Any devices intended to be handled by users must be so designed as not to impair their safety if used foreseeably in a manner not in accordance with the posted instructions.'

This essential requirement is satisfied by the functional and technical specifications in clauses:

- 4.2.2.2 (end couplers and coupling arrangements to rescue trains)
- 4.2.2.4 (access)
- 4.2.2.5 (toilets)
- 4.2.4 (braking)
- 4.2.5.3 (passenger alarm)
- 4.2.7.1 (emergency exits)
- 4.2.7.3 (protection against electric shock)
- 4.2.7.5 (lifting/rescue procedures)
- 4.2.9 (servicing)
- 4.2.10 (maintenance)

3.3.2. Reliability and availability

Essential requirement 1.2:

'The monitoring and maintenance of fixed or moveable components that are involved in train movements must be organised, carried out and quantified in such a manner as to maintain their operation under the intended conditions.'

This essential requirement is satisfied by the functional and technical specifications in clauses:

- 4.2.2.2 (end couplers and coupling arrangements to rescue trains)
- 4.2.2.3 (strength of vehicle structure)
- 4.2.2.4 (access)

- 4.2.3.1 (kinematic gauge)
- 4.2.3.3.2 (axle bearing health monitoring)
- 4.2.3.4 (rolling stock dynamic behaviour)
- 4.2.3.9 (suspension coefficient)
- 4.2.4 (braking)
- 4.2.7.10 (monitoring and diagnostic concepts)
- 4.2.10 (maintenance)

3.3.3. Health requirements

Essential requirement 1.3.1:

'Materials likely, by virtue of the way they are used, to constitute a health hazard to those having access to them must not be used in trains and railway infrastructures.'

This essential requirement is satisfied by the functional and technical specifications in clauses:

- 4.2.10 (maintenance)

Essential requirement 1.3.2:

'Those materials must be selected, deployed and used in such a way as to restrict the emission of harmful and dangerous fumes or gases, particularly in the event of fire.'

This essential requirement is satisfied by the functional and technical specifications in clauses:

- 4.2.7.2 (fire safety)
- 4.2.10 (maintenance)

3.3.4. Protection of the environment

Essential requirement 1.4.1:

'The repercussions on the environment of the establishment and operation of the Trans-European high-speed rail system must be assessed and taken into account at the design stage of the system in accordance with the Community provisions in force.'

This essential requirement is satisfied by the functional and technical specifications in clauses:

- 4.2.3.11 (ballast pick up)
- 4.2.6.2 (train aerodynamic load)
- 4.2.6.5 (exterior noise)
- 4.2.6.6 (exterior electromagnetic interference)
- 4.2.9 (servicing)
- 4.2.10 (maintenance)

Essential requirement 1.4.2:

'The materials used in the trains must prevent the emission of fumes or gases which are harmful and dangerous to the environment, particularly in the event of fire.'

This essential requirement is satisfied by the functional and technical specifications in clauses:

- 4.2.7.2 (fire safety)
- 4.2.10 (maintenance)

Essential requirement 1.4.3:

'The rolling stock and energy-supply systems must be designed and manufactured in such a way as to be electromagnetically compatible with the installations, equipment and public or private networks with which they might interfere.'

This essential requirement is satisfied by the functional and technical specifications in clauses:

- 4.2.6.6 (exterior electromagnetic interference)

3.3.5. Technical compatibility

Essential requirement 1.5:

'The technical characteristics of the infrastructures and fixed installations must be compatible with each other and with those of the trains to be used on the Trans-European high-speed rail system.'

'If adherence to these characteristics proves difficult on certain sections of the network, temporary solutions, which ensure compatibility in the future, may be implemented.'

This essential requirement is satisfied by the functional and technical specifications in clauses:

- 4.2.2.4 (access)
- 4.2.3.1 (kinematic gauge)
- 4.2.3.2 (static axle load)
- 4.2.3.3 (rolling stock parameters which influence ground based train monitoring systems)
- 4.2.3.4 (rolling stock dynamic behaviour)
- 4.2.3.5 (maximum train length)
- 4.2.3.6 (maximum gradients)
- 4.2.3.7 (minimum curve radius)
- 4.2.3.8 (flange lubrication)
- 4.2.3.11 (ballast pick up)
- 4.2.4 (braking)
- 4.2.6.2 (train aerodynamic load)
- 4.2.6.4 (maximum pressure variations in tunnels)
- 4.2.7.11 (particular specification for tunnels)
- 4.2.8.3 (functional and technical specification related to power supply)
- 4.2.9 (servicing)
- 4.2.10 (maintenance)

3.4. Requirements specific to the rolling stock subsystem

3.4.1. Safety

Essential requirement 2.4.1 § 1:

The rolling stock structures and those of the links between vehicles must be designed in such a way as to protect the passenger and driving compartments in the event of collision or derailment.'

This essential requirement is satisfied by the functional and technical specifications in clauses:

- 4.2.2.2 (end couplers and coupling arrangements to rescue trains)
- 4.2.2.3 (strength of vehicle structure)

Essential requirement 2.4.1 § 2:

The electrical equipment must not impair the safety and functioning of the control-command and signalling installations.'

This essential requirement is satisfied by the functional and technical specifications in clauses:

- 4.2.6.6 (exterior electromagnetic interference)
- 4.2.8.3 (functional and technical specification related to power supply)

Essential requirement 2.4.1 § 3:

The braking techniques and the stresses exerted must be compatible with the design of the tracks, engineering structures and signalling systems.'

This essential requirement is satisfied by the functional and technical specifications in clauses:

- 4.2.3.4.3 (track loading limit values)
- 4.2.4.1 (minimum braking performance)
- 4.2.4.5 (eddy current brakes)

Essential requirement 2.4.1 § 4:

'Steps must be taken to prevent access to electrically-live constituents in order not to endanger the safety of persons.'

This essential requirement is satisfied by the functional and technical specifications in clauses:

- 4.2.5.2 (passenger information signs)
- 4.2.7.3 (protection against electric shock)
- 4.2.9 (servicing)
- 4.2.10 (maintenance)

Essential requirement 2.4.1 § 5:

'In the event of danger, devices must enable passengers to inform the driver and accompanying staff to contact him.'

This essential requirement is satisfied by the functional and technical specifications in clauses:

- 4.2.5 (passenger information and communication)

Essential requirement 2.4.1 § 6:

The access door must incorporate an opening and closing system which guarantees passenger safety.'

This essential requirement is satisfied by the functional and technical specifications in clauses:

- 4.2.2.4.2 (external access door)

Essential requirement 2.4.1 § 7:

'Emergency exits must be provided and indicated.'

This essential requirement is satisfied by the functional and technical specifications in clauses:

- 4.2.5.2 (passenger information signs)
- 4.2.7.1 (emergency exits)

Essential requirement 2.4.1 § 8:

'Appropriate provisions must be laid down to take account of the particular safety conditions in very long tunnels.'

This essential requirement is satisfied by the functional and technical specifications in clauses:

- 4.2.5.3 (passenger alarm)
- 4.2.7.2 (fire safety)
- 4.2.7.11 (particular specification for tunnels)
- 4.2.7.12 (emergency lighting system)

Essential requirement 2.4.1 § 9:

'An emergency lighting system having a sufficient intensity and duration is an absolute requirement on board trains.'

This essential requirement is satisfied by the functional and technical specifications in clause:

- 4.2.7.12 (emergency lighting system)

Essential requirement 2.4.1 § 10:

'Trains must be equipped with a public address system which provides a means of communication to the public from on-board staff and ground control.'

This essential requirement is satisfied by the functional and technical specifications in clause:

- 4.2.5 (passenger information and communication)

3.4.2. Reliability and availability

Essential requirement 2.4.2:

'The design of the vital equipment and the running, traction and braking equipment and also the control command system must, in a specific degraded situation, be such as to enable the train to continue without adverse consequences for the equipment remaining in service.'

This essential requirement is satisfied by the functional and technical specifications in clauses:

- 4.2.1.1 (introduction)
- 4.2.1.2 (design of the trains)
- 4.2.2.2 (end couplers and coupling arrangements to rescue trains)
- 4.2.4.1 (minimum braking performance)
- 4.2.4.2 (brake wheel/rail adhesion demand limits)
- 4.2.4.3 (brake system requirements)
- 4.2.4.4 (service braking performance)
- 4.2.4.6 (protection of an immobilised train)
- 4.2.4.7 (brake performance on steep gradients)
- 4.2.5.1 (public address system)
- 4.2.7.2 (fire safety)
- 4.2.7.10 (monitoring and diagnostic concepts)
- 4.2.7.12 (emergency lighting system)
- 4.2.8.1 (traction performance requirements)
- 4.2.8.2 (traction wheel/rail adhesion requirements)
- 4.2.10 (maintenance)

3.4.3. Technical compatibility

Essential requirement 2.4.3 § 1:

The electrical equipment must be compatible with the operation of the control command and signalling installations.'

This essential requirement is satisfied by the functional and technical specifications in clauses:

- 4.2.6.6 (exterior electromagnetic interference)
- 4.2.8.3 (functional and technical specification related to power supply)

Essential requirement 2.4.3 § 2:

The characteristics of the current-collection devices must be such as to enable trains to travel under the energy supply systems for the Trans-European high-speed rail system.'

This essential requirement is satisfied by the functional and technical specifications in clause:

- 4.2.8.3 (functional and technical specification related to power supply)

Essential requirement 2.4.3 § 3:

The characteristics of the rolling stock must be such as to allow it to travel on any line on which it is expected to operate.'

This essential requirement is satisfied by the functional and technical specifications in clauses:

- 4.2.2.4 (access)
- 4.2.3.1 (kinematic gauge)
- 4.2.3.2 (static axle load)
- 4.2.3.3 (rolling stock parameters which influence ground based train monitoring systems)
- 4.2.3.4 (rolling stock dynamic behaviour)
- 4.2.3.5 (maximum train length)
- 4.2.3.6 (maximum gradients)
- 4.2.3.7 (minimum curve radius)
- 4.2.3.11 (ballast pick up)
- 4.2.4 (braking)
- 4.2.6 (environmental conditions)
- 4.2.7.4 (external lights and horn)
- 4.2.7.9 (control-command and signalling system)
- 4.2.7.11 (particular specification for tunnels)
- 4.2.8 (traction and electrical equipment)
- 4.2.9 (servicing)
- 4.2.10 (maintenance)
- 4.8 (infrastructure and rolling stock registers)

3.5. **Requirements specific to maintenance**

Essential Requirement 2.5.1 Health:

The technical installations and the procedures used in the maintenance centres must not constitute a danger to human health.'

This essential requirement is satisfied by the functional and technical specifications in sections:

- 4.2.9 (servicing)
- 4.2.10 (maintenance)

Essential Requirement 2.5.2 Environmental protection:

The technical installations and the procedures used in the maintenance centres must not exceed the permissible levels of nuisance with regard to the surrounding environment.'

This essential requirement is satisfied by the functional and technical specifications in clauses:

- 4.2.6.5 (exterior noise)
- 4.2.6.6 (exterior electromagnetic interference)

- 4.2.9 (servicing)
- 4.2.10 (maintenance)

Essential Requirement 2.5.3 Technical compatibility:

'The maintenance installations [handling] high-speed trains must be such as to enable safety, health and comfort operations to be carried out on all trains for which they have been designed.'

This essential requirement is satisfied by the functional and technical specifications in sections:

- 4.2.9 (servicing)
- 4.2.10 (maintenance)

3.6. **Other requirements also concerning the rolling stock subsystem**

3.6.1. Infrastructure

Essential Requirement 2.1.1. Safety

'Appropriate steps must be taken to prevent access to or undesirable intrusions into installations on lines travelled at high speed.'

'Steps must be taken to limit the dangers to which persons are exposed, particularly in stations through which trains pass at high speed.'

'Infrastructures to which the public has access must be designed and made in such a way as to limit any human health hazards (stability, fire, access, evacuation, platforms, etc.).'

'Appropriate provisions must be laid down to take account of the particular safety conditions in very long tunnels.'

This essential requirement is not relevant to the scope of this TSI.

3.6.2. Energy

Essential Requirement 2.2.1. Safety

'Operation of the energy-supply systems must not impair the safety either of high-speed trains or of persons (users, operating staff, trackside dwellers and third parties).'

This essential requirement is not relevant to the scope of this TSI.

Essential Requirement 2.2.2. Environmental protection

'The functioning of the energy-supply systems must not interfere with the environment beyond the specified limits.'

This essential requirement is satisfied by the functional and technical specifications in clauses:

- 4.2.6.6 (exterior electromagnetic interference)
- 4.2.8.3.6 (Rolling stock requirements linked to pantographs)

Essential Requirement 2.2.3. Technical compatibility

'The electricity supply systems used throughout the trans-European high-speed rail system must:

- enable trains to achieve the specified performance levels;
- be compatible with the collection devices fitted to the trains.'

This essential requirement is satisfied by the functional and technical specifications in clause:

- 4.2.8.3 (functional and technical specification related to power supply)

3.6.3. Control-command and signalling

Essential Requirement 2.3.1. Safety

'The control and command and signalling installation and procedures used on the trans-European high-speed rail system must enable trains to travel with a level of safety which corresponds to the objectives set for the network.'

This essential requirement is not relevant to the scope of this TSI.

Essential Requirement 2.3.2. Technical compatibility

'All new high-speed infrastructures and all new high-speed rolling stock manufactured or developed after adoption of compatible control and command and signalling must be tailored to the use of those systems.'

'The control and command and signalling equipment installed within the train drivers' cabs must permit normal operation, under the specified conditions, throughout the trans-European high-speed rail system.'

This essential requirement is satisfied by the functional and technical specifications in clauses:

- 4.2.3.2 (static axle load)
- 4.2.3.3 (rolling stock parameters which influence ground based train monitoring systems)
- 4.2.6.6.1 (interference generated on the signalling system and the telecommunications network)
- 4.2.7.9 (control-command and signalling system)
- 4.2.8.3.10 (interfaces with control, command and signalling system)

3.6.4. Environment

Essential Requirement 2.6.1. Health:

'Operation of the trans-European high-speed rail system must remain within the statutory noise nuisance limits.'

This essential requirement is satisfied by the functional and technical specifications in clauses:

- 4.2.6.5 (exterior noise)
- 4.2.7.6 (interior noise)

Essential Requirement 2.6.2. Environmental protection

'Operation of the trans-European high-speed rail system must not cause a level of ground vibrations which is unacceptable for activities and the immediate environment in the vicinity of the infrastructure and in a normal state of maintenance.'

This essential requirement is not relevant to the scope of this TSI.

3.6.5. Operation

Essential Requirement 2.7.1. Safety § 1

'Alignment of the network operating rules and the qualifications of drivers and on-board staff must be such as to ensure safe international operation.'

This essential requirement is satisfied by the functional and technical specifications in the following section:

- 4.2.7.8 (driver's vigilance device)

Essential Requirement 2.7.1. Safety § 2

'The operations and maintenance intervals, the training and qualifications of maintenance staff and the quality assurance system set up in the maintenance centres of the operators concerned must be such as to ensure a high level of safety.'

This essential requirement is satisfied by the functional and technical specifications in sections:

- 4.2.9 (servicing)
- 4.2.10 (maintenance)

Essential Requirement 2.7.2. Reliability and availability

'The operation and maintenance periods, the training and qualifications of the maintenance staff and the quality assurance system set up by the operators concerned in the maintenance centres must be such as to ensure a high level of system reliability and availability.'

This essential requirement is satisfied by the functional and technical specifications in clause:

- 4.2.10 (maintenance)

Essential Requirement 2.7.3. Technical compatibility

'The alignment of the operating rules of the networks and the qualifications of drivers, on-board staff and managers in charge of traffic must be such as to ensure operating efficiency on the trans-European high-speed rail system.'

This essential requirement is satisfied by the functional and technical specifications in sections:

- 4.2.10 (maintenance)

3.7.

Elements of the rolling stock subsystem related to the essential requirements

Element of the rolling stock subsystem	Ref. clause of TSI	Essential requirement clause of Directive 96/48/EC as modified by Directive 2004/50/EC				
		Safety	Reliability Availability	Health	Environmental protection	Technical compatibility
General	4.2.1		2.4.2			
Structure and mechanical parts	4.2.2					
Design of the trains	4.2.1.2		2.4.2			
End couplers and coupling arrangements to rescue trains	4.2.2.2	1.1.1 1.1.3 1.1.5 2.4.1.1	1.2 2.4.2			
Strength of vehicle structure	4.2.2.3	1.1.1 1.1.3 2.4.1.1	1.2			
Access	4.2.2.4	1.1.1 1.1.5	1.2			1.5 2.4.3.3
Access door	4.2.2.4.2	2.4.1.6				
Toilets	4.2.2.5	1.1.5				
Driver's cab	4.2.2.6	1.1.1				
Windscreen & front of the train	4.2.2.7	1.1.1 1.1.3				
Track interaction and gauging	4.2.3					
Kinematic gauge	4.2.3.1	1.1.1	1.2			1.5 2.4.3.3
Static axle load	4.2.3.2	1.1.2				1.5 2.4.3.3 2.3.2
Rolling stock parameters which influence ground based train monitoring systems	4.2.3.3	1.1.1				1.5 2.4.3.3 2.3.2
Axle bearing health monitoring	4.2.3.3.2	1.1.3	1.2			
Rolling stock dynamic behaviour	4.2.3.4	1.1.1 1.1.2	1.2			1.5 2.4.3.3
Track loading limit values	4.2.3.4.3	1.1.3 2.4.1.3				
Wheelsets	4.2.3.4.9	1.1.3				
Maximum train length	4.2.3.5					1.5 2.4.3.3
Maximum gradients	4.2.3.6					1.5 2.4.3.3
Minimum curve radius	4.2.3.7					1.5 2.4.3.3
Flange lubrication	4.2.3.8					1.5
Suspension coefficient	4.2.3.9		1.2			
Sanding	4.2.3.10	1.1.1				

Element of the rolling stock subsystem	Ref. clause of TSI	Essential requirement clause of Directive 96/48/EC as modified by Directive 2004/50/EC				
		Safety	Reliability Availability	Health	Environmental protection	Technical compatibility
Aerodynamic effects on ballast	4.2.3.11	1.1.1			1.4.1	1.5 2.4.3.3
Braking	4.2.4	1.1.1 1.1.3 1.1.5	1.2			1.5 2.4.3.3
Minimum braking performance	4.2.4.1	2.4.1.3	2.4.2			
Brake wheel/rail adhesion demand limits	4.2.4.2		2.4.2			
Brake system requirements	4.2.4.3		2.4.2			
Service Braking Performance	4.2.4.4		2.4.2			
Eddy current brakes	4.2.4.5	2.4.1.3				
Protection of an immobilised train	4.2.4.6		2.4.2			
Brake performance on steep gradients	4.2.4.7		2.4.2			
Passenger information and communication	4.2.5	1.1.1 2.4.1.5 2.4.1.10				
Public address system	4.2.5.1		2.4.2			
Passenger information signs	4.2.5.2	2.4.1.4 2.4.1.7				
Passenger alarm	4.2.5.3	1.1.5 2.4.1.8				
Environmental conditions	4.2.6					2.4.3.3
Environmental conditions	4.2.6.1	1.1.3				
Train aerodynamic loads in open air	4.2.6.2	1.1.1			1.4.1	1.5
Crosswind	4.2.6.3	1.1.1 1.1.3				
Maximum Pressure Variations in Tunnels	4.2.6.4	1.1.1 1.1.3				1.5
Exterior Noise	4.2.6.5			2.6.1	1.4.1 2.5.2	
Exterior Electromagnetic Interference	4.2.6.6	1.1.1 2.4.1.2			1.4.1 1.4.3 2.5.2 2.2.2	2.4.3.1
Interference generated on the signalling system and the telecommunications network	4.2.6.6.1					2.3.2
System protection	4.2.7	1.1.1				
Emergency exits	4.2.7.1	1.1.5 2.4.1.7				
Fire safety	4.2.7.2	1.1.3 1.1.4 2.4.1.8	2.4.2	1.3.2	1.4.2	
Protection against electric shock	4.2.7.3	1.1.5 2.4.1.4				

Element of the rolling stock subsystem	Ref. clause of TSI	Essential requirement clause of Directive 96/48/EC as modified by Directive 2004/50/EC				
		Safety	Reliability Availability	Health	Environmental protection	Technical compatibility
External lights and horn	4.2.7.4					2.4.3.3
Lifting/rescue procedures	4.2.7.5	1.1.5				
Interior Noise	4.2.7.6			2.6.1		
Air Conditioning	4.2.7.7					
Driver's Vigilance Device	4.2.7.8	2.7.1				
Control-command system	4.2.7.9	1.1.1				2.4.3.3 2.3.2
Monitoring and Diagnostic Concepts	4.2.7.10		1.2 2.4.2			
Particular specification for tunnels	4.2.7.11	2.4.1.8				1.5 2.4.3.3
Emergency lighting system	4.2.7.12	2.4.1.8 2.4.1.9	2.4.2			
Software	4.2.7.13	1.1.1				
Traction and electrical equipment	4.2.8					2.4.3.3
Traction performance requirements	4.2.8.1		2.4.2			
Traction wheel/rail adhesion requirements	4.2.8.2		2.4.2			
Functional and technical specification related to power supply	4.2.8.3	2.4.1.2			2.2.3	1.5 2.4.3.1 2.4.3.2
Pantographs and contact strips	4.2.8.3.6				2.2.2	
Interfaces with control, command and signalling system	4.2.8.3.8					2.3.2
Servicing	4.2.9	1.1.3 1.1.5 2.4.1.4 2.7.1		2.5.1	1.4.1 2.5.2	1.5 2.4.3.3 2.5.3
Maintenance	4.2.10	1.1.3 1.1.5 2.4.1.4 2.7.1	1.2 2.4.2 2.7.2	1.3.1 1.3.2 2.5.1	1.4.1 1.4.2 2.5.2	1.5 2.4.3.3 2.5.3 2.7.3
Infrastructure and rolling stock registers	4.8					2.4.3.3

4. CHARACTERISTICS OF THE SUBSYSTEM

4.1. Introduction

The rolling stock subsystem shall be verified in accordance with Directive 96/48/EC as modified by Directive 2004/50/EC with the objective of assuring interoperability in respect of the essential requirements.

The functional and technical specifications of the subsystem and its interfaces, described in sections 4.2 and 4.3, shall not impose the use of specific technologies or technical solutions, except where this is strictly necessary for the interoperability of the trans-European High Speed rail network. Innovative solutions, which do not fulfil the requirements, specified in this TSI and/or which are not assessable as stated in this TSI require new specifications and/or new assessment methods. In order to allow technological innovation, these specifications and assessment methods shall be developed by the process described in clauses 6.1.4 and 6.2.3.

The common characteristics of rolling stock subsystem are defined in section 4 of this TSI. Particular characteristics are listed in the rolling stock register (see Annex I of this TSI)

4.2. **Functional and technical specification of the subsystem**

4.2.1. General

4.2.1.1. Introduction

The basic parameters for the rolling stock subsystem are:

- Maximum Track Forces (track loading limit values)
- Axle Load
- Maximum Train Length
- Vehicle Kinematic Gauge
- Minimum Braking Characteristics
- Electrical Boundary Characteristics for Rolling Stock
- Mechanical Boundary Characteristics for Rolling Stock
- Exterior Noise Limits
- Electromagnetic Interference Limits
- Interior Noise Limits
- Air Conditioning Limits
- Requirements for the Transport of People with Reduced Mobility
- Maximum Pressure Variations in Tunnels
- Maximum Gradients
- Geometry of the pantograph collector head
- Maintenance

Performance criteria for the Trans-European high-speed network shall be met for the specific requirements for each of the following line categories as appropriate for the class of train:

- Lines specifically built for high speed,
- Lines specifically upgraded for high speed,
- Lines specifically upgraded for high speed but with special features,

as described in Annex I § 1 of Directive 96/48/EC as modified by Directive 2004/50/EC.

For the rolling stock subsystem these requirements are:

(a) Minimum Performance Requirements

In order to run on the trans-European high-speed network and under conditions allowing trains to slot smoothly into the overall traffic pattern, all high-speed rolling stock shall be required to guarantee minimum traction and braking performance levels. The trains shall have sufficient standby and backup capacity to ensure that these performance levels are maintained or only slightly downgraded in case of breakdown in systems or modules contributing to these processes (traction equipment from pantograph to axles, mechanical/electrical braking equipment). These margins and redundancies are defined in detail in the characteristics contained in clauses 4.2.1, 4.2.4.2, 4.2.4.3, 4.2.5.1, 4.2.4.7, 4.2.7.2, 4.2.7.12, 4.2.8.1, and 4.2.8.2.

For safety significant failures of rolling stock equipment or functions described in this TSI, or passenger overload, the rolling stock keeper and/or the railway undertaking shall, have defined the operating rules associated with each reasonably foreseeable degraded mode in full knowledge of the consequences as defined by the manufacturer. The operating rules are part of the safety management system of the railway undertaking and are not required to be verified by a notified body. For this purpose, the manufacturer shall describe and list in a document the various reasonably foreseeable degraded modes and the related acceptable limits and operating conditions of the rolling stock subsystem that can be experienced. This document shall be part of the technical file according to § 4 of annex VI of Directive 96/48/EC as modified by Directive 2004/50/EC and shall be taken into account in the operational rules.

(b) Maximum service speed of trains

Trains shall have in conformity with Article 5(3) and Annex I of the Directive 96/48/EC modified by Directive 2004/50/EC a maximum service speed of:

- at least 250 km/h for class 1 trains;
- at least 190 km/h, but less than 250 km/h for class 2 trains.

The service speed is the nominal speed trains are expected to run in daily operation on appropriate sections.

In all cases, it shall be possible for rolling stock to be worked at their maximum speed (if allowed by the infrastructure) with sufficient acceleration margins (as specified in the following paragraphs).

4.2.1.2. Design of trains

- (a) This TSI is applicable to both trainsets and single vehicles, but always assessed within defined formations of powered and non-powered vehicles.
- (b) For both classes of train the following configurations are permissible:
- articulated and/or non-articulated trains,
 - trains with and/or without tilt systems,
 - single and/or double deck trains.
- (c) Class 1 trains shall be self-propelled trainsets and shall provide a driver's cab at each end and be capable of bi-directional operation and to achieve the performance stated in this TSI. To allow train capacity to meet changing traffic needs it is permissible to couple trainsets to run in multiple. Such a train formed from two or more trainsets shall also meet the relevant specifications and performance in this TSI. It is not a requirement that trainsets of different manufacturers' designs, or trains from other railway undertakings shall be able to operate coupled together.

- (d) Class 2 trains shall be either trainsets, or trains of variable formation with or without bi-directional capabilities. They shall be capable of the performance stated in this TSI. To allow train capacity to meet changing traffic needs it is permissible to couple Class 2 trains to run in multiple, or to add vehicles in the case of trains with locomotives and coaches, where they remain in defined formations. Such a train formed from two or more trains shall meet the relevant specifications and performance in this TSI. It is not a requirement that trainsets of different manufacturers' designs, or trains from other railway undertakings shall be able to operate coupled together under normal conditions.
- (e) To allow train capacity to meet changing traffic needs it is permissible to couple Class 1 and Class 2 trains to run in multiple. Such a train formed from two or more trains shall meet the relevant specifications and performance in this TSI. It is not a requirement that trainsets of different manufacturers' designs, or trains from other railway undertakings shall be able to operate coupled together.
- (f) For both classes of trains, whether assessing a trainset or a single vehicle within one or more formations, the formations for which such assessments are valid shall be clearly defined by the party asking for assessment, and clearly stated in the type or design examination certificate of 'EC' verification. It is not permissible to assess a single vehicle without reference to a specific formation. The definition of each formation shall include the type designation, the number of vehicles and TSI relevant characteristics of the vehicles (as listed in the rolling stock register).
- (g) The characteristics of each vehicle in a train shall be such that the train fulfils the requirement of this TSI. Some requirements are capable of being assessed for a single vehicle and some have to be assessed with reference to a defined formation as defined in section 6 for each requirement.
- (h) The formation(s) for which each assessment is valid shall be clearly defined in the type or design examination certificate of 'EC' verification.

Definitions

1. A **trainset** is a fixed formation that can only be reconfigured within a workshop environment, if at all.
2. **EMU/DMU (Electric/Diesel Multiple Unit)**, are trainsets, where all vehicles are capable of carrying a payload.

Traction and other equipment are usually, but not exclusively under-floor.

3. A **Power Head** is a traction vehicle of a trainset with a single driver's cab at one end, which is not capable of carrying a payload.
4. A **Locomotive** is a traction vehicle that is not capable of carrying a payload and has the ability to uncouple in normal operation from a train and operate independently.
5. A **coach** is a non-traction vehicle in a fixed or variable formation capable of carrying a payload. It is permitted to equip such a coach with a driver's cab. Such a coach is named a driving coach.
6. A **train** is an operational formation consisting of one or more vehicles or trainsets
7. **Defined formation** see 4.2.1.2.f

4.2.2. Structure and mechanical parts

4.2.2.1. General

This section deals with the requirements for coupling arrangements, vehicle structures, access, toilets, drivers cabs, windscreens and the front-end designs of the train.

- 4.2.2.2. End couplers and coupling arrangements to rescue trains
- 4.2.2.2.1. Subsystem requirements
- (a) Class 1 trains shall be equipped at each end of the train with an automatic centre buffer coupler as defined in clause 4.2.2.2.2.1. This is to enable such trains to be rescued in the event of a breakdown by another Class 1 train.
- (b) Class 2 trains shall be equipped at each end either
- with an automatic centre buffer coupler as defined in clause 4.2.2.2.2.1
 - or with buffing and draw gear components compliant with clause 4.2.2.2.2.2.
 - or with a permanent adaptor meeting the requirements
 - of clause 4.2.2.2.2.1
 - or of clause 4.2.2.2.2.2.
- (c) All trains equipped with automatic centre buffer couplers meeting the requirements of clause 4.2.2.2.2.1 shall be provided with a towing coupler as defined in clause 4.2.2.2.2.3 available on board. This is to enable such trains to be rescued or recovered in the event of a breakdown by motive power units or other trains, equipped with buffing and draw components compliant to clause 4.2.2.2.2.2.
- (d) Provision to enable Class 1 and 2 trains to be rescued in the event of a breakdown is required only by a motive power unit or another train equipped with automatic centre buffer couplers meeting the requirements of clause 4.2.2.2.2.1 or with buffing and draw components compliant to clause 4.2.2.2.2.2.
- (e) Requirements for the pneumatic brake equipment of high speed trains for towing in case of emergency rescue are specified in clause 4.2.4.8. and in clause K.2.2.2 of Annex K.
- 4.2.2.2.2. Interoperability constituent requirements
- 4.2.2.2.2.1. Automatic centre buffer coupler
- Automatic centre buffer couplers shall be geometrically and functionally compatible with a 'Type 10 latch system automatic centre buffer coupler' (also known as the 'Scharfenberg' system) as shown in Annex K clause K.1.
- 4.2.2.2.2.2. Buffing and draw gear components
- The buffing and draw gear components shall be compliant with clause 4.2.2.1.2 of the Conventional Rail Rolling Stock Freight Wagons TSI 2005.
- 4.2.2.2.2.3. Towing coupler for recovery and rescue
- Towing couplers for recovery and rescue shall meet the requirements of Annex K clause K.2.
- 4.2.2.3. Strength of vehicle structure
- 4.2.2.3.1. General description
- The static and dynamic strength of vehicle bodies shall ensure the safety required for the occupants.
- The railway safety system is based on active and passive safety.
- Active safety: Systems which reduce the probability of an accident occurring or the severity of the accident
 - Passive safety: Systems which reduce the consequences of an accident, should it occur

Passive safety systems shall not be used to compensate for a possible lack of active safety in the railway network but shall be complementary to active safety in order to complement personal safety when all other measures have failed.

4.2.2.3.2. Principles (functional requirements)

In the event of a frontal impact as described in the scenarios below, the mechanical structure of vehicles shall:

- Limit deceleration,
- Maintain survival space and structural integrity of the occupied areas,
- Reduce the risk of derailment.
- Reduce the risk of over-riding,

Deformation shall be controlled in order to, as a minimum, absorb the energy of the design collision scenarios. Deformation shall be progressive, without overall instabilities or failures and shall occur in the designated collapse zones only. Collapse zones can be:

- reversible and irreversible deformable parts of the buffing/coupling gears;
- non-structural devices;
- crumple zones in the car-body;
- or any combination of the above.

The crumple zones shall either be located in non-occupied areas close to the extremities of each vehicle, in front of the cab and in inter-car gangways, or if this is not possible in adjacent areas of temporary occupation (for example toilets or vestibules) or cabs. Crumple zones are not allowed in passenger seating areas including those equipped with folding (tip up) seats.

4.2.2.3.3. Specifications (simple load cases and design collision scenarios)

- (a) The structural elements of the body shell of each vehicle shall be able to withstand the longitudinal and vertical static loads for the vehicle bodies corresponding to category P II of EN12663:2000 as a minimum.
- (b) Four collision scenarios shall be considered:
 - A front end impact between two identical trains,
 - A front end impact with a vehicle fitted with side buffers,
 - An impact with a lorry on a level crossing.
 - An impact with a low obstacle

The details for the above scenarios and the corresponding criteria are to be found in annex A.

4.2.2.4. Access

4.2.2.4.1. Passenger step

This is specified in detail by clauses 4.2.2.12.1, 4.2.2.12.2 and 4.2.2.12.3 in the TSI for Accessibility for Persons With Reduced Mobility.

4.2.2.4.2. External access door

4.2.2.4.2.1. Passenger access doors

The relevant clauses of 4.2.2.4. of the TSI for Accessibility for Persons With Reduced Mobilit. will also apply.

(a) Terminology used:

- a 'closed door' is a door held closed by the door closing mechanism only
- a 'locked door' is a door held closed by a mechanical door locking device
- a 'door locked out of service' is immobilised in a closed position by a mechanical device activated by a member of the train crew.

(b) Door operation:

To latch or unlatch a manually operated door, for use by the public, the control device shall be operable by the palm of the hand exerting a force not exceeding 20 Newton.

The force required to open or close a manual door shall not exceed:

If pushbuttons are provided for the powered operation of doors then each pushbutton shall be illuminated (or the surround shall be illuminated) when enabled and shall be operable by a force not greater than 15 Newton.

(c) Door closing:

The door control device shall allow the train crew (driver or conductor) to close and lock the doors before the train departs.

When the locking control is under staff control and activated from a door, it is permissible for this door to remain open when the other doors close. It shall be possible for staff to close and lock this door subsequently. This door shall automatically close when the train reaches 5 km/h after which locking shall be initiated.

The doors shall be kept closed and locked until the train crew releases them.

In the event of loss of power to the door controls, the doors shall be kept locked by the locking mechanism.

An audible warning sound shall be activated before the doors start to close.

(d) Information available to the train crew:

An appropriate device shall indicate to the driver or the train crew that all the doors (except for the door under local control of the train crew) are closed and locked.

Appropriate indication shall be provided to the driver or the train crew of any fault in the door closing operation.

A 'door locked out of service' shall not be taken into account.

(e) Locking a door out of service:

A manual device shall be provided to enable the train crew to lock a door out of service. This action shall be possible from both inside and outside the train.

After the door is locked out of service, it shall no longer be taken into account by the door controls or the onboard monitoring systems.

- (f) Door opening release: The train crew shall be provided with controls that allow the doors to be released separately on each side, to allow them to be opened by passengers when the train is stopped.
- (g) Door opening control: A normal opening control or opening device shall be accessible for passengers from both the outside and the inside of the vehicle.

Each door shall be provided with one of the following systems, either system shall be equally acceptable to all Member States:

- an individual internal emergency-opening device, accessible to passengers, that shall allow the door only to be opened at speeds below 10 km/h.,
- or
- an individual internal emergency-opening device, accessible to passengers, that shall allow the door to be opened. This device shall be independent of any speed signal. This device shall be operated after a succession of at least two actions.

This device shall have no effect on 'a door locked out of service'. In such a case the door shall be unlocked first.

Each door shall be provided with an individual external emergency-opening device, accessible to rescue staff, to allow that door to be opened for emergency reasons. This device shall have no effect on 'a door locked out of service'. In such an emergency case the door shall be unlocked first.

- (h) The number of the doors and their dimensions shall allow the complete evacuation within three minutes by passengers without their baggage in a situation where the train is stopped alongside a platform. It is permitted to consider that passengers with reduced mobility are to be assisted by other passengers or staff, and that wheelchair users are evacuated without their wheelchair. Verification of this requirement shall be made by a physical test with a normal load as defined in clause 4.2.3.2 and under normal operating conditions.
- (i) Doors shall be fitted with transparent windows to allow passengers to identify the presence of a platform.

4.2.2.4.2.2. Doors for freight use and for use of the train crew

A device shall allow the driver or train crew to close and lock the doors before the train departs.

The doors shall be kept closed and locked until the driver or train crew releases them.

4.2.2.5. Toilets

On passenger carrying trains, sealed retention toilets shall be installed onboard. Flushing is permissible with either clean water or by re-circulation techniques.

If the flushing medium is not clean water, the characteristics of the flushing medium shall be recorded in the rolling stock register.

4.2.2.6. Driver's cab

- (a) access and egress

The cab shall be accessible from both sides of the train from the platforms as defined in the High-Speed Infrastructure TSI 2006 and from a level 200mm below the top of the rail on a stabling track.

It is permissible for this access to be either directly from the exterior or through an adjoining compartment at the rear of the cab.

The train crew shall be able to prevent the cab being accessed by non-authorised persons.

(b) External visibility

Forward Vision: The driver's cab shall be designed such that a driver has a clear, unobstructed line of sight to be able to see fixed signals set to both the left and right of the track from the normal seated driving position as defined in Annex B, Figures B.1, B.2, B.3, B.4 and B.5, when the train is on a level and straight track, with the signals following locations defined in Annex B, measured from either the coupling face or the buffer plane (whichever is applicable). Consideration of a standing driving position is not required

Side vision: The driver shall be provided with an opening window or opening panel, sufficiently large for the driver to put his head through the aperture, at each side of the cab. Additional equipment for side and rearwards vision is not mandatory.

(c) Seats:

The main seat available to the driver shall be designed in such a way that it allows him to undertake all normal driving functions in a seated position. Requirements related to health, safety and ergonomics are an open point.

In addition, a second forward facing seat shall be provided for possible accompanying crew. The requirements for external visibility given in section b) do not apply to this position.

(d) Interior layout:

Freedom of movement of personnel in the cab interior shall not be inhibited by obstructions. Steps are not permitted on the cab floor; they are permitted between the cab and adjacent compartments or outside doors. The interior layout shall take into account the anthropometric dimensions of the driver as set out in Annex B..

4.2.2.7. Windscreen and front of the train

The driver's cab windscreens shall:

- (a) be of an optical quality in accordance with the following characteristics: The types of safety glass used for the front windows, and any heated windows (windows heated to prevent frost) of drivers' cabs shall not alter the colour of signals and their quality shall be such that the glass, when pierced or starred, remains in position and affords staff protection and sufficient visibility to enable the train to continue its journey. These requirements are set out in clause J.1 of Annex J.
- (b) be equipped with de-icing, de-misting and external cleaning facilities.
- (c) be able to resist impacts from projectiles as specified in clause J.2.1 of Annex J and resist spalling as specified in clause J.2.2 of Annex J.

The front end of the train shall be capable of resisting the same impact as the window in order to protect persons travelling in the front vehicle.

The inside face of the windscreen shall be supported along its edges to limit intrusion in case of an accident.

4.2.2.8. Storage facilities for use by staff

In or near to driver cabs and where a train is equipped with a separate service compartment there shall be adequate storage facilities for clothing and equipment that must travel with the staff.

4.2.2.9. External steps for use by shunting staff

Where a train

- is equipped with UIC couplers
- is of variable consist
- and external steps for use by shunting staff are required

such steps shall conform to the requirements of clause 4.2.2.2 of CR RST Freight Wagon TSI.

4.2.3. Track interaction and gauging

4.2.3.1. Kinematic gauge

Rolling stock shall comply with one of the kinematic vehicle gauges defined in Annex C of the Conventional Rail Rolling Stock Freight Wagon TSI 2005.

The pantograph gauge shall comply with Clause 5.2 of prEN 50367:2006

The type or design examination certificate of 'EC' verification of the rolling stock and the rolling stock register shall indicate the assessed gauge.

4.2.3.2. Static axle load

The nominal static axle load (P_0) on the track shall meet the following requirements, in order to limit the forces exerted on the track by the train. Measurements shall be made under the following normal load conditions: with normal payload, train crew, all materials needed for operation (e.g. lubricants, coolants, catering equipment, flushing medium for toilets etc.) and 2/3 of consumables (e.g. fuel, sand, food, etc).

The following definition of the normal payload will apply, dependant upon the type of vehicle or area:

- Passenger seating areas including seats in dining cars: number of passenger seats multiplied by 80 kg (stools (low and high), resting bars or standing aids are not classified as seats)
- Areas of temporary occupation (e.g. vestibules, gangways, toilets): no passenger payload to be taken into account
- Other compartments not accessible to passengers containing luggage, freight: maximum payload in revenue service

The different types of vehicles are defined in clause 4.2.1.2.

The nominal static load P_0 per axle shall be as set out in Table 1 (1 tonne (t) = 1 000 kg):

Table 1
Static axle load

	Maximum service speed V [km/h]				
	$190 \leq V \leq 200$	$200 < V \leq 230$	$230 < V < 250$	$V = 250$	$V > 250$
Class 1				≤ 18 t	≤ 17 t
Class 2 locomotives and powerheads	$\leq 22,5$ t		≤ 18 t	n/a	n/a
Class 2 multiple units	≤ 20 t	≤ 18 t		n/a	n/a
Class 2 loco hauled coaches	≤ 18 t			n/a	n/a

The maximum total static axle load of the train (the total mass of the train) shall not be greater than:

(the sum of all nominal static axle loads of the train) x 1,02.

The total mass of the train shall not exceed 1 000 t

The maximum individual static axle load of any axle shall not be greater than:

(the nominal individual static axle load) x 1,04.

The difference in static wheel load between any wheel on the same bogie or running gear shall not exceed 6 % of the average wheel load of that bogie or running gear. It is permitted to centre the car body to the centre lines of the bogies before the weighing process.

Individual static axle loads shall not be less than 5 t. This value satisfies the requirement specified in clauses 3.1.1, 3.1.2 and 3.1.3 of Annex A Appendix 1 of the Control-Command and Signalling TSI 2006.

4.2.3.3. Rolling stock parameters which influence ground based train monitoring systems

4.2.3.3.1. Electrical resistance

To ensure the operation of track circuits, the electrical resistance of each wheelset, measured from tyre to tyre shall meet the requirements of clause 3.5 of Annex A Appendix 1 of the Control-Command and Signalling TSI:2006.

In the case of independent wheels (left and right parallel wheels that rotate independently), it is necessary to electrically connect the pair of wheels to achieve the above values.

4.2.3.3.2. Axle bearing health monitoring

4.2.3.3.2.1. Class 1 trains

The health of wheelset bearings on Class 1 trains shall be monitored by on board detection equipment.

This equipment shall be able to detect a deterioration of the wheelset bearing health, either by monitoring its temperature, or its dynamic frequencies or some other suitable wheelset bearing health condition characteristic. A maintenance requirement shall be generated by this equipment and indicate a need for operational restrictions when necessary depending on the extent of the wheelset bearing deterioration.

The detection system shall be located entirely on board and diagnosis messages shall be communicated to the driver.

Specification and assessment method for on board detection equipment are an open point

To prevent Class 1 trains triggering an incorrect alarm of trackside hot axle box detection (HABD) equipment, Class 1 trains shall have no component (other than axle boxes), or vehicle part, or commodity, that generates sufficient heat in the target area, defined in clause 4.2.3.3.2.3, that triggers an alarm. Where such a possibility exists then that component, vehicle part or commodity that has the possibility of generating an alarm shall be permanently shielded from the trackside HABD equipment.

It is permissible for Class 1 train axle boxes, by mutual agreement between all the infrastructure managers to whose lines the trains are intended to run and the railway undertaking, to interface with trackside HABD, in addition to the on board detection equipment, if all the requirements of clause 4.2.3.3.2.3 are fulfilled. As an alternative it is permissible by mutual agreement between infrastructure manager and railway undertaking to identify these trains by train identification systems and use the HABD information as agreed.

When, for vehicles with independent rotating wheels, inhibition of false alarms by using the train identification number is not possible, priority shall be given to the on-board detection system provided that all bearings of the wheels are monitored. The rolling stock register shall indicate if the axle boxes that have the possibility of generating an alarm are or are not shielded permanently from the trackside HABD equipment.

4.2.3.3.2.2. Class 2 trains

It is not required to equip Class 2 trains with on board detection system unless their hot axle box bearings cannot be detected by the systems of trackside detection defined in TSI Control-Command Signalling TSI: 2006 Annex A Appendix 2.

Where a Class 2 train is equipped with on board detection system for wheelset bearing health monitoring equipment the requirements of clause 4.2.3.3.2.1 shall be applied.

The wheelset bearing health of Class 2 trains, that are not equipped with on board wheelset bearing health monitoring equipment, shall be able to be monitored by trackside Hot Axle Box Detector (HABD) equipment to detect abnormal wheelset bearing temperature rises, and shall meet the vehicle interface requirements set out in clause 4.2.3.3.2.3.

4.2.3.3.2.3. Hot axle box detection for Class 2 trains

4.2.3.3.2.3.1. General

The minimum area on a vehicle that shall remain clear for the observation and measurement of axle box temperatures by trackside HABD equipment, known as the target area (TA), shall comply with the requirements given in clause 4.2.3.3.2.3.3 and 4.2.3.3.2.3.4.

4.2.3.3.2.3.2. Functional requirements for the vehicle

The vehicle's axle box shall be designed such that the maximum temperature difference between the loaded zone of the bearing and the target area shall not exceed 20 °C when assessed by the methods defined in Annex 6 of EN12082:1998, Rig performance test.

A minimum of three alarm trigger levels shall apply to Class 2 trains on the axle box target area temperatures ($T_{\text{axle box}}$) as measured by the trackside HABD equipment:

- (a) Warm alarm: $T_{\text{axle box open point}} \text{ } ^\circ\text{C}$
- (b) Hot alarm: $T_{\text{axle box open point}} \text{ } ^\circ\text{C}$
- (c) Difference alarm (Difference between the temperature of the right and the left bearing of a wheelset = ΔT_{diff}): $\Delta T_{\text{diff open point}} \text{ } ^\circ\text{C}$

As an alternative to this requirement on alarm trigger levels, it is permissible by mutual agreement between the infrastructure-manager and the railway undertaking to identify trains by train identification systems and use specific alarm trigger levels as agreed, that are different from the above levels. Specific alarm trigger levels shall be listed in the rolling stock register

4.2.3.3.2.3.3. Transverse dimensions and height above rail level of the target area

For rolling stock intended to be used on 1 435 mm track gauge the target area on the underside of an axle box, that shall remain un-obstructed to permit observation by a trackside HABD, shall occupy a minimum uninterrupted length of 50mm within a minimum transverse distance from the wheelset-centre of 1 040 mm and a maximum transverse distance from the wheelset centre of 1 120 mm at a height above the top of the rail between 260 mm and 500 mm.

4.2.3.3.2.3.4. Longitudinal dimension of the target area

The longitudinal dimension on the underside of the axle box that shall remain unobstructed to permit observation by a trackside HABD (see Figure 1) shall:

- be centred on the wheelset's centreline,
- have a minimum length L_{min} (mm) = 130mm for Class 1 trains where used
- have a minimum length L_{min} (mm) =100mm for Class 2 trains

4.2.3.3.2.3.5. Limit criteria outside of the target area

To prevent unwanted activation of the trackside HABD, in the vertical plane and over a minimum longitudinal length of L_E mm (= 500 mm) centred on the wheelset centreline:

- (a) No component, or vehicle part, or commodity that has a temperature greater than that of the axle box (e.g. hot load, engine exhaust) shall be located within the longitudinal limit of L_E mm and at a distance of less than 10 mm from either outer edge of the target area's transverse limits (as given in 4.2.3.3.2.3.3) unless it is shielded from observation by the trackside HABD.
- (b) No component, vehicle part or commodity that has the potential to increase the temperature of a component or part that lies within the longitudinal limit of L_E mm and the target area transverse limits to a temperature above that of the wheelset-box (e.g. engine exhaust), shall be located at a distance of less than 100 mm from either outer edge of the target area's transverse limits (as shown in 4.2.3.3.2.3.3) unless it is shielded and prevented from causing an increase in temperature of any part within that area.

4.2.3.3.2.3.6. Emissivity

In order to maximise the emissivity of the observed target area surface and to limit stray radiation from the axle box, the underside surfaces of the axle box and its immediate environment shall be designed to have a matt finish and be painted with dark paint of a matt finish. The paint used shall be to a specification of a maximum 5 % specular reflection in its new state (as defined in clause 3.1 of EN ISO 2813:1999) and be appropriate for the axle box surfaces to which it is applied.

Figure 1

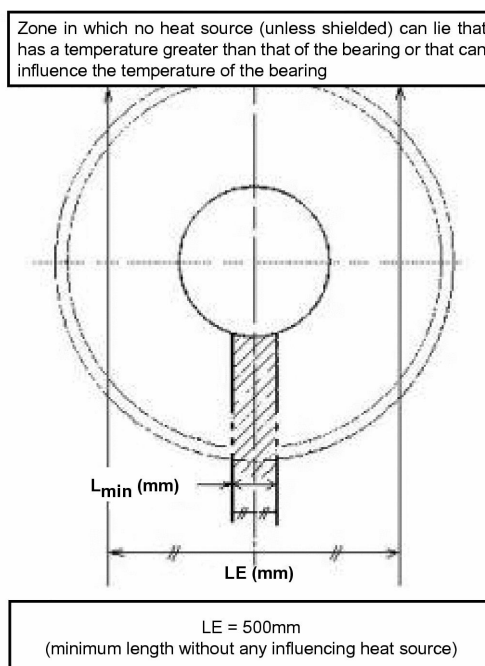

4.2.3.4. Rolling stock dynamic behaviour

4.2.3.4.1. General

The dynamic behaviour of a vehicle has a strong influence on safety against derailment, running safety and track loading. The vehicle dynamic behaviour is mainly determined by:

- the maximum speed
- the maximum designed cant deficiency for the rolling stock
- wheel/rail contact parameters (wheel and rail profile, track gauge)
- mass and inertia of the car body, bogies and wheelsets
- suspension characteristic of the vehicles
- track irregularities

In order to ensure safety against derailment and running safety, as well as to avoid overloading of the track, an acceptance procedure test shall be carried out for vehicles which:

- are newly developed,
 - have had relevant design modifications that could affect safety against derailment, running safety or track loading
- or
- have had changes in their operating regimes that could affect safety against derailment, running safety or track loading.

The acceptance procedure tests for safety against derailment, running safety and track loading shall be carried out in accordance with the relevant requirements in EN14363:2005. The parameters described in 4.2.3.4.2 and 4.2.3.4.3, below, shall be assessed (using the normal or simplified method as permitted in EN14363:2005 Clause 5.2.2). More details about these parameters are given in EN14363:2005.

The EN14363 takes account of the present state of the art. However the requirements are not always achievable in the following areas:

- track geometric quality
- combinations of speed, curvature, cant deficiency.

These requirements remain as open points within this TSI.

The tests shall be carried out under a range of conditions of speed, cant deficiency, track quality and curve radius appropriate for the application of the vehicle.

The track geometric quality for the tests shall be representative of the service routes and shall be included in the test report. The methodology of EN14363 Annex C shall be used with the specified QN1 and QN2 values taken as guidance. However they do not represent the range of geometric quality that may occur.

Some aspects of EN14363 are also not consistent with the requirements of the HS RST TSI:

- contact geometry
- loading conditions.

In accordance with EN14363:2005 it is permitted to deviate from the requirements laid down in this clause 4.2.3.4 where evidence can be provided that safety is equivalent to that achieved by complying with these requirements.

4.2.3.4.2. Limit values for running safety

EN14363:2005 (Clauses 4.1.3, 5.5.1, 5.5.2 and appropriate sections of clauses 5.3.2, 5.5.3, 5.5.4, 5.5.5 and 5.6) contains definitions of the frequency content, measuring methods and conditions for the parameters specified in sections a), b) and c) below.

(a) Transverse track forces:

Rolling stock shall comply with the PRUD'HOMME criteria for the maximum transverse force ΣY defined as follows:

$$(\Sigma Y)_{\max, \lim} = 10 + \frac{P_0}{3} \text{ kN},$$

where ΣY is the sum of the guiding forces of a wheelset and P_0 is the static load on the axle in kN defined in clause 4.2.3.2. The result of this formula defines the limit of wheel/rail adhesion between the sleeper and the ballast under the influence of transverse dynamic forces.

(b) Quotient of the transverse and vertical forces of a wheel in normal operating conditions (for a Curve Radius $R \geq 250$ m):

The ratio of transverse to vertical force (Y/Q) of a wheel shall not exceed the limit

$$(Y/Q)_{\lim} = 0,8$$

where Y is the lateral guiding force of a wheel exerted on the rail measured in a wheelset based reference frame and Q is the vertical force of the wheel on the rail measured in the same reference frame.

(c) Quotient of the transverse and vertical forces of a wheel on twisted track (For a Curve Radius $R < 250$ m).

The ratio of transverse to vertical force (Y/Q) of a wheel shall not exceed the limit

$$(Y/Q)_{\lim} = \frac{\tan \gamma - 0,36}{1 + 0,36 \tan \gamma}$$

with the flange angle γ .

Note:

If the flange angle γ is 70 degrees the limit value $(Y/Q)_{\lim} = 1,2$.

This limit characterises the ability of the rolling stock to run on twisted track.

(d) Instability criterion

Definition: On straight track or large radius curves a wheelset is running in an unstable manner if the periodic lateral movement of the wheelset exhausts the clearance between the wheel flanges and the gauge corner of the rails. In unstable motion this lateral movement is exerted over several cycles and is strongly dependent on:

— Speed

and

- Equivalent conicity (defined in clause 4.2.3.4.6) where relevant (see clause 4.2.3.4.10);

and causes excessive lateral vibrations.

- (d1) The rms value of the sum of the guiding forces used in the acceptance testing shall not exceed the limit

$$\Sigma Y_{\text{rms,lim}} = \Sigma Y_{\text{max,lim}}/2$$

where $\Sigma Y_{\text{max,lim}}$ is defined in section a) of this clause.

This limit characterises the ability of the rolling stock to run in a stable manner

(rms = root mean square)

- (d2) The criteria for the activation of an on board instability alarm shall follow either:

- the requirements of clause 5.3.2.2 and clause 5.5.2 of EN14363:2005 for simplified acceleration measurement method or
- indicate instability characterised by a maintained lateral oscillation (more than 10 cycles) generating accelerations of the bogie frame above the centreline of the wheelset greater than 0,8g peak value, with a frequency between 3 and 9 Hz.

4.2.3.4.3. Track loading limit values

The frequency content, measuring methods and conditions for the parameters specified in sections a), c) and d) below are defined in EN14363:2005 (Clauses 5.5.1, 5.5.2 and appropriate sections of clauses 5.3.2, 5.5.3, 5.5.4, 5.5.5 and 5.6).

- (a) Vertical dynamic wheel load

The maximum vertical force exerted by the wheels on the rails (dynamic wheel load, Q) shall not be more than the value given in Table 2 for the speed range of the vehicle:

Table 2

Dynamic wheel load

V (km/h)	Q (kN)
190 < V ≤ 250	180
250 < V ≤ 300	170
V > 300	160

- (b) Longitudinal load

In order to limit the longitudinal forces exerted on the track by the rolling stock the maximum acceleration or deceleration shall be less than 2,5 m/s².

Braking systems which dissipate kinetic energy through heating the rail shall not create braking forces of more than:

case 1: 360 kN per train in the case of emergency braking,

case 2: for other braking cases, such as a normal service braking for speed reduction or non repetitive braking to a halt, or repetitive braking for speed control, the use of the brake and the maximum braking force allowed shall be determined by the infrastructure manager for each line concerned. Any limitations on the braking force defined in clause 4.2.4.5 shall be justified and published in the infrastructure register and taken into account in the operating rules.

(c) Quasi static guiding force Y_{qst}

Limitation of the quasi static guiding force Y_{qst} is to avoid excessive wear of rails in curves.

National rules apply (see Annex L)

(d) Quasi static wheel force Q_{qst}

In order to limit the vertical forces in curves at cant deficiency and cant excess the quasi static vertical wheel force shall be less than

$$Q_{qst,lim} = 145 \text{ kN.}$$

4.2.3.4.4. Wheel/rail interface

The wheel-rail interface is fundamental for safety against derailment and for explaining the dynamic running behaviour of a railway vehicle. The wheel profile shall meet the following requirements:

- (a) The flange angle (see Annex M) is at least 67 degrees
- (b) The taper angle (see Annex M) is between 3,7 and 8,5 degrees (6,5 % to 15 %).
- (c) The equivalent conicity is in the limits set out in Sections 4.2.3.4.6 to 4.2.3.4.8.

4.2.3.4.5. Design for vehicle stability

Vehicles shall be designed to be stable on track meeting the requirements of the High-Speed Infrastructure TSI 2006 at the maximum vehicle design speed plus 10 %. Unstable running is defined in clause 4.2.3.4.2 (d).

Rolling stock designed for higher speeds shall still be stable when running on lines designed for lower speeds. For example, rolling stock designed for speeds >250 km/h shall still be stable when running on lines designed for speeds of the order of 200 km/h or less.

The range of values of speed and conicity for which the vehicle is designed to be stable shall be specified, certified and indicated in the rolling stock register.

If stability is dependent on the use of devices, which are not fail-safe, an on board instability alarm shall be fitted on trains with a speed that exceeds 220 km/h. The detection of instability shall be based on acceleration measurements taken on the bogie frame. This alarm shall advise the driver to reduce speed in the event of instability. The criteria for activation of this alarm shall be as defined in clause 4.2.3.4.2 d2.

4.2.3.4.6. Definition of equivalent conicity

Equivalent conicity is the tangent of the cone angle of a wheelset with coned wheels whose lateral movement has the same kinematic wavelength as the given wheelset on straight track and large-radius curves.

The limiting values for equivalent conicity quoted in the tables below shall be calculated for the amplitude (y) of the wheelset's lateral displacement

- $y = 3 \text{ mm,}$ if $(TG - SR) \geq 7 \text{ mm}$
- $y = \left(\frac{(TG - SR) - 1}{2} \right),$ if $5 \text{ mm} \leq (TG - SR) < 7 \text{ mm}$
- $y = 2 \text{ mm,}$ if $(TG - SR) < 5 \text{ mm}$

where TG is the track gauge and SR is the distance between the active faces of the wheelset.

4.2.3.4.7. Design values for wheel profiles

Wheel profiles and the distance between active faces of the wheels (Dimension S_R in Annex M) shall be selected to ensure that the equivalent conicity limits set out in Table 3 are not exceeded when the designed wheelset is modelled passing over the representative sample of track test conditions (simulated by calculation) specified in Table 4.

Table 3

Equivalent conicity design limit values

Maximum vehicle operating speed (km/h)	Equivalent conicity limit values	Test conditions (see Table 4)
≥ 190 and ≤ 230	0,25	1, 2, 3, 4, 5 and 6
> 230 and ≤ 280	0.20	1, 2, 3, 4, 5 and 6
> 280 and ≤ 300	0,10	1, 3, 5 and 6
> 300	0,10	1 and 3

Table 4

Modelling track test conditions for equivalent conicity

Test condition No.	Rail head profile	Rail inclination	Track gauge
1	rail section 60 E 1 defined in EN 13674-1:2003	1 in 20	1 435 mm
2	rail section 60 E 1 defined in EN 13674-1:2003	1 in 40	1 435 mm
3	rail section 60 E 1 defined in EN 13674-1:2003	1 in 20	1 437 mm
4	rail section 60 E 1 defined in EN 13674-1:2003	1 in 40	1 437 mm
5	rail section 60 E 2 defined in Annex F of HS INS TSI 2006	1 in 40	1 435 mm
6	rail section 60 E 2 defined in Annex F of HS INS TSI 2006	1 in 40	1 437 mm

The requirements of this clause are deemed to have been met by wheelsets having unworn S1002 or GV 1/40 profiles, as defined in prEN13715:2006 with spacing of active faces between 1 420 mm and 1 426 mm.]

Note: Design conicity values for rail profiles are given in The High Speed Infrastructure TSI 2006. Those values are different from the values given here for wheel profiles. This difference is intentional and results from the selection of reference wheel and rail profiles for the assessment.

4.2.3.4.8. In service values of equivalent conicity

Assessment of this clause is the responsibility of the Member State(s) where the rolling stock is operated. This clause is excluded from the assessment made by a notified body.

The maintenance plan shall set out the railway undertaking's procedures for maintaining wheelsets and wheel profiles. The procedures shall take account of the conicity ranges for which the vehicle is certified (see clause 4.2.3.4.5).

Wheelsets shall be maintained to ensure (directly or indirectly) that the equivalent conicity remains within the approved limits for the vehicle when the wheelset is modelled passing over the representative sample of track test conditions (simulated by calculation) specified in Tables 4 and 5.

Table 5

Simulated track test conditions for in service values of equivalent conicity

Maximum vehicle operating speed (km/h)	Test conditions (see Table 4)
≥ 190 and ≤ 200	1, 2, 3, 4, 5 and 6
> 200 and ≤ 230	1, 2, 3, 4, 5 and 6
> 230 and ≤ 250	1, 2, 3, 4, 5 and 6
> 250 and ≤ 280	1, 2, 3, 4, 5 and 6
> 280 and ≤ 300	1, 3, 5 and 6
> 300	1 and 3

For a novel bogie/vehicle design, or for operation of a known vehicle on a route with relevant different characteristics, then the development of wear of a wheel profile, and therefore the change in equivalent conicity, is usually not known. For this situation a provisional maintenance plan shall be proposed. The validity of the plan shall be confirmed following monitoring of the wheel profile and equivalent conicity in service. The monitoring shall consider a representative number of wheelsets and shall take into account the variation between wheelsets in different positions in the vehicle and between different vehicle types in the trainset.

If ride instability is reported, the railway undertaking shall model the measured wheel profiles and distances between active faces of the wheels (Dimension S_R in Annex M) over the representative sample of track test conditions specified in Table 5 and Table 4 to check for compliance with the maximum equivalent conicity at which the vehicle is designed and certified to be stable.

If the wheelsets comply with the maximum equivalent conicity at which the vehicle is designed and certified to be stable, the High-Speed Infrastructure TSI 2006 requires the infrastructure manager to check the track for compliance with the requirements set out in the High-Speed Infrastructure TSI 2006.

If both vehicle and track comply with the requirements of the relevant TSIs, a joint investigation by the railway undertaking and the infrastructure manager shall be undertaken to determine the reason for the instability.

4.2.3.4.9. Wheelsets

4.2.3.4.9.1. Wheelsets

(a) Geometrical dimensions

The maximum and minimum dimensions for wheelsets for standard track gauge (1 435 mm) are given in Annex M.

(b) Requirements linked to control-command and signalling subsystem

The requirements related to electrical resistance of wheelsets linked to control-command and signalling subsystem are specified in clause 4.2.3.3.1.

4.2.3.4.9.2. Interoperability Constituent Wheels

(a) Geometrical dimensions

The maximum and minimum dimensions for wheels for standard track gauge (1 435 mm) are given in Annex M.

(b) Wear Criteria Characteristics

To achieve a proper match between the choice of materials for the rail (as defined in the High-Speed Infrastructure TSI 2006) and the wheels, the wheels shall use materials defined as follows:

- For the entire wheel rim wearing depth, the values of Brinell hardness (HB) of the material shall be greater than or equal to 245;
- If the thickness of the zone of wear is greater than 35 mm, the value of 245 HB shall be obtained to a depth of 35 mm below the bearing surface.
- The value of hardness at the interface between the wheel centre and the wheel rim shall be at least 10 points less than when measured at the maximum depth of wear

(c) Requirements linked to control-command and signalling subsystem

The requirements related to geometry and material for wheels linked to control-command and signalling subsystem are specified in clause 4.2.7.9.3

4.2.3.4.10. Specific requirements for vehicles with independently rotating wheels

A vehicle equipped with independently rotating wheels shall have the following characteristics:

- (a) suspension/bogie design to ensure stable behaviour of the axle/bogie in curves
- (b) a method to centre the axle in the track when running on straight track
- (c) wheel dimensions complying with the requirements given in Annex M of this TSI

Equivalent conicity requirements (sections 4.2.3.4.6 to 4.2.3.4.8) do not apply to vehicles equipped with wheels rotating independently and therefore wheel profiles not complying with these conicity requirements may be used for vehicles with independent wheels.

The other dynamic behaviour requirements (sections 4.2.3.4.1 to 4.2.3.4.4 (b)) for vehicles with wheelsets do apply to vehicles equipped with independent wheels.

4.2.3.4.11. Detection of derailments

Derailment detection systems shall be installed on new builds of Class 1 trainsets, when their specification for interoperability is established and they are available on the market.

As long as the specification for interoperability of derailment detection systems is not available, installation of derailment detection systems is not mandatory.

4.2.3.5. Maximum train length

The length of trains shall not exceed 400 m. A tolerance of 1 % is permissible in order to improve aerodynamic penetration of the front and rear of the train.

To maximise access to the high-speed Trans European Network the maximum length of trains shall be compatible with the usable length of platform specified in the High-Speed Infrastructure TSI 2006.

4.2.3.6. Maximum gradients

Trains shall be able to start, operate and stop on the maximum gradients on all the lines for which they are designed and over which they are likely to operate.

This is of particular relevance to the performance requirements specified in this TSI.

The maximum gradients of each line are defined in the infrastructure register. Clauses 4.2.5 and 7.3.1 of the High Speed Infrastructure TSI 2006 state the maximum permitted gradients.

4.2.3.7. Minimum curve radius

This parameter is an interface with the high-speed infrastructure subsystem in that the minimum curvatures to be taken into account are defined on one hand for the high-speed tracks (based on the cant deficiency) and on the other hand for the stabling tracks. Reference shall be made to clause 2.2 of the infrastructure register and clauses 4.2.6 and 4.2.24.3 of the High-Speed Infrastructure TSI 2006.

4.2.3.8. Flange lubrication

To protect the rails and wheels against excessive wear, particularly in curves, trains shall be equipped with flange lubrication. This shall be installed as a minimum on one axle close to the leading end of a train.

After such a lubrication the wheel tread/rail contact area shall not be contaminated.

4.2.3.9. Suspension coefficient

Whenever a stationary vehicle is placed on a canted track whose running surface lies at an angle δ to the horizontal, its body leans on its suspension and forms an angle η with the perpendicular to the rail level. The vehicle suspension coefficient s is defined by the ratio:

$$s = \frac{\eta}{\delta}$$

This parameter influences the swept envelope of a vehicle. The suspension coefficient s of vehicles equipped with pantographs shall be less than 0,25. It is permissible for tilting trains not to meet this requirement providing they are equipped with pantograph compensation devices.

4.2.3.10. Sanding

Sanding devices shall be provided for improving braking and traction performance.. The amount of sand distributed along the rail is specified in clause 4.1.1 of Annex A Appendix 1 of the Control-Command and Signalling TSI 2006. The maximum number of active sanding devices is defined in clause 4.1.2 of Annex A Appendix 1 of the Control-Command and Signalling TSI 2006. There shall be provision on rolling stock to permit interruption of sanding:

- within switching zones
- when at standstill except during starting and testing of the sanding devices
- during braking at speeds below 20 km/h.

4.2.3.11. Ballast pick up

This is an open point.

4.2.4. Braking

4.2.4.1. Minimum braking performance

- (a) Trains shall incorporate a brake control system with one or more deceleration levels. The prescribed performance levels defining the minimum braking power are given in Tables 6 and 7. Meeting these performance levels and the safe operation of the braking system shall be fully demonstrated.
- (b) It is important to note that the values in Table 6 below are those appropriate for rolling stock and they shall not be interpreted as being the absolute values for defining the braking curves required by the control-command and signalling subsystem.

- (c) Performance: trains shall be able to achieve, over the range of speeds shown, the minimum mean decelerations within each the speed range shown below.

Table 6

Minimum braking performance levels

Braking mode	t_e [s]	Minimum mean deceleration measured between end of t_e and reaching the target speed [m/s ²]			
		350-300 (km/h)	300-230 (km/h)	230-170 (km/h)	170-0 (km/h)
Case A — Emergency braking with specific equipment isolated	3	0,75	0,9	1,05	1,2
Case B — Emergency braking with specific equipment isolated and unfavourable climatic conditions	3	0,60	0,7	0,8	0,9

t_e [s] = Equivalent time of application: the sum of the delay period and half of the brake force build up time, where the build up time is defined as the time needed to reach 95 % of the braking force demanded.

Case A

- Level track and normal train load as defined in clause 4.2.3.2 on dry rails ⁽¹⁾

and the worst degraded operation mode defined below:

- One dynamic brake unit, which is able to function independently of the other dynamic brake units, is deactivated if it is independent of the contact wire, or all units on the dynamic brake are deactivated if they are dependent on the voltage in the contact wire.
- Or one independent module of the braking system, which dissipates kinetic energy through heating the rails, is inoperable, if this system is independent of the dynamic brake.

Case B

As per case A and

- One distributor valve or equivalent self-supporting control device acting on the friction brake from one or two carrying bogies is deactivated.

and

- Reduced wheel/rail adhesion

and

- Brake pad/brake disc friction coefficient reduced as a result of dampness.

The complete process of assessment is described in annex P

Note 1: On existing infrastructures, infrastructure managers are permitted to define further requirements because of the different Class B signalling and control systems on their part of trans-European high-speed network (see infrastructure register), e.g. additional braking systems or reduced service speeds for given braking distances.

Note 2: Normal service braking conditions are defined in clause 4.2.4.4.

⁽¹⁾ In cases where loading is not possible, alternative methods are permissible, such as simulation by isolating further brake units provided they do not introduce significant errors in the procedure

- (d) Stopping distances: The stopping distance 'S' calculated as a function of the minimum decelerations defined above is defined by the formula:

$$S = V_0 \times t_e + \frac{V_0^2 - V_1^2}{2ab_1} + \frac{V_1^2 - V_2^2}{2ab_2} + \dots + \frac{V_n^2}{2ab_{n+1}}$$

where:

- V_0 = initial speed (m/s)
 $V_0 \dots V_n$ = speed given in Table 6 (m/s)
 $ab_1 \dots ab_{n+1}$ = specified deceleration over the speed band under consideration (m/s²)
 t_e = Equivalent time of application (s)

For example, using the data in Table 6, the following stopping distances to be met from specific initial speeds are given in Table 7.

Table 7

Maximum stopping distance

Braking mode	t_e [s]	Stopping distances shall not exceed [m]			
		350-0 (km/h)	300-0 (km/h)	250-0 (km/h)	200-0 (km/h)
Case A — emergency braking with specific equipment isolated	3	5 360	3 650	2 430	1 500
Case B — Emergency braking with specific equipment isolated and unfavourable climatic conditions	3	6 820	4 690	3 130	1 940

- (e) Additional conditions:

For the Cases A & B, when emergency braking is considered:

The contribution of electric dynamic brakes shall only be included in the calculation of the performance defined above if

- Either their operation is independent of the presence of voltage in the catenary or
- it is permitted by the Member State

It is permissible to include the contribution of braking systems that dissipate kinetic energy through heating the rails in the emergency braking performance under the conditions defined in clause 4.2.4.5.

Electromagnetic brakes with magnets that are in contact with the rail shall not be employed at speeds higher than 280 km/h. It is permissible to include the contribution made by electromagnetic brakes independent of wheel rail adhesion for emergency braking on all lines as a means of maintaining the envisaged braking performance.

4.2.4.2. Brake wheel/rail adhesion demand limits

The design of the train and the calculation of its braking performance shall not assume wheel/rail adhesion values in excess of the following values. For speeds below 200 km/h, the maximum wheel/rail adhesion coefficient demand during braking shall be assumed to be no more than 0,15. For speeds above 200 km/h, the wheel/rail adhesion coefficient maximum demand shall be assumed to decline linearly to 0,1 at 350 km/h.

A train in full service condition and with a normal load (as defined in 4.2.3.2) shall be used in calculations to verify the braking performance.

4.2.4.3. Brake system requirements

In addition to the needs listed in clauses 4.2.4.1 and 4.2.4.2, the braking system shall be proved to meet the safety objectives set within Directive 96/48/EC. This requirement is met by using for example UIC compliant braking systems.

For other braking systems, a demonstration is required to prove a level of performance at least as safe as that provided by the UIC compliant braking system.

The brake system shall meet the following requirements:

For the complete train:

- Use of the emergency brake, for whatever reason, shall automatically cut all traction power, without the facility of reapplying traction power while the emergency brake is being applied.
- The emergency brake shall be capable of being applied at all times with the driver in his normal driving position
- Vehicles shall be fitted with wheel-slide devices to control the sliding of wheels in the event of reduced adhesion between wheel and rail,
- Class 1 trains shall be equipped with a wheel rotation monitoring system to advise the driver that an axle has seized. The wheel slide protection device and the rotation monitoring system shall function independently.
- Emergency brake applications actuated via the driver's brake valve or additional emergency brake control as well as via the monitoring and speed control equipment shall have the following immediate and simultaneous effects:
 - A rapid pressure drop in the main brake pipe to ≤ 2 bar. The cab shall be equipped with both a drivers brake valve and an additional emergency brake control to provide redundancy.
 - An interruption in re-filling of main brake pipe

In the case of short trains less than 250 m in length and if the equivalent time of application t_e of 3 s or less is met when the emergency brake is applied, it is not mandatory to interrupt re-filling of the main brake pipe.

- An application of the electro-pneumatic brake (ep brake) if fitted

In the case of short trains less than 250 m in length and if the equivalent time of application t_e of 3 s or less is met when the emergency brake is applied, it is not mandatory to control the electro pneumatic brake.

- An application of full brake force corresponding to performance set out in 4.2.4.1,
- A traction cut-off.
- Service braking: application of full service braking shall result in a traction cut-off without an automatic restoration of traction power.
- Full service braking is defined as the braking resulting from the maximum braking force within the range of service braking before emergency braking.

Electric braking

- The contribution of electric brakes shall be in accordance with requirements of clause 4.2.4.1.e
- Where the electrical installations (the sub-stations) permit, the return of electrical energy generated in braking is permissible, but this shall not cause the voltage to exceed the limits defined in EN50163:2004 clause 4.1.

All vehicles shall be provided with a means of brake isolation and indicators of brake status.

In addition, trains with a maximum speed greater than 200km/h shall be provided with a system of (brake) fault diagnostics.

4.2.4.4. Service braking performance

In addition to the specifications required in clause 4.2.4.1 'minimum braking characteristics', the trains shall comply with the average decelerations in service defined in Table 8.

Table 8

Minimum mean deceleration levels for service braking

Braking mode	t_e	Minimum mean deceleration measured between end of t_e and reaching the target speed [m/s^2]			
	[s]	350-300 (km/h)	300-230 (km/h)	230-170 (km/h)	170-0 (km/h)
Service braking	2	0,30	0,35	0,6	0,6

t_e [s] = Equivalent time of application

These decelerations shall be achieved by a train on level track, in the configurations defined in clause 4.2.4.1 Cases A.

4.2.4.5. Eddy current brakes

This paragraph deals with the infrastructure subsystem interfaces relating to eddy current track brakes.

As specified in the High-Speed Infrastructure TSI 2006, the use of this type of brake, independent of wheel/rail adhesion, on the lines (to be built, upgraded or connecting) of the trans-European high-speed network is permissible as follows:

- For emergency braking on all lines except specific connecting lines listed in the infrastructure register.
- For full or normal service braking on the sections of line where the infrastructure manager permits it. In this case the conditions of use shall be published in the infrastructure register.

Trains equipped with this type of brake shall meet the following specifications:

- Brakes independent of wheel rail adhesion are permitted to be used from the maximum operating speed down to 50 km/h: ($V_{max} \geq V \geq 50$ km/h)
- The maximum average deceleration shall be less than 2,5 m/s² (this value, which is an interface with the longitudinal resistance of the track, shall be met with all brakes in use).
- In the worst case, that is to say with the trainsets working in multiple to their maximum permitted train length, the maximum longitudinal braking force applied to the track by the eddy current train brake shall be:
 - 105 kN for brake applications with a force lower than 2/3 of full service braking
 - Linear between 105 kN and 180 kN for brake applications between 2/3 and full service braking,
 - 180 kN for full service braking
 - 360 kN in emergency braking

It is permissible to include the contribution of brakes independent of wheel/rail adhesion in the braking performance defined in clause 4.2.4.1. This is with the understanding that the safe operation of this type of brake can be assured and is not affected by any single point failure.

4.2.4.6. Protection of an immobilised train

In the event of the compressed air supply being disrupted or the power supply failing, it shall be possible to stop and hold a train with a normal load (as defined in clause 4.2.3.2) on a 35‰ gradient by using the friction brake alone, even if one distributor valve is switched off, for at least two hours.

It shall be possible to keep a train with a normal load stationary for an unlimited period on a 35‰ gradient. Should the parking brake be unable to achieve this on its own, further means of securing the train shall be available on board.

4.2.4.7. Brake performance on steep gradients

The brake thermal performance shall allow a train to run on a maximum gradient set out in clause 4.2.5 of the High Speed Infrastructure TSI 2006 at a speed of at least equivalent to 90 % of the maximum train operating speed. This thermal performance shall be used for calculating the limiting gradient where maximum train speed can be operated.

The same conditions for train loading, means of braking and rail condition apply as for emergency braking case A as defined in clauses 4.2.4.1 c and e. Compliance to this requirement shall be proven by calculation.

4.2.4.8. Brake requirements for rescue purposes

Requirements for the pneumatic brake equipment of high speed trains for towing in case of emergency rescue are as follows:

1. Filling time of the brake cylinder to 95 % maximum pressure: 3-5 seconds, 3-6 seconds with load-braking system.
2. Release time of the brake cylinder to 0.4 bar pressure: a minimum of 5 seconds.
3. Reduction in brake pipe pressure required to obtain maximum brake cylinder pressure: $1,5 \pm 0,1$ bar (coming from a nominal value in the brake pipe of $5,0 \pm 0,05$ bar).
4. The sensitivity of the brake to slow decreases in brake pipe pressure shall be such, that the brake is not activated if the normal working pressure drops by 0,3 bars in one minute.
5. The sensitivity of the brake to decreases in brake pipe pressure shall be such, that the brake is activated within 1,2 seconds, if the normal working pressure drops by 0,6 bar in 6 seconds.
6. Each brake, including the parking brake, shall have an on/off device.
7. A minimum of five steps of brake force shall be available by variation of the brake pipe pressure.
8. The status (applied/released) of brakes, including the parking brake, shall be indicated.

Where the on-board train braking system is initiated by other than pneumatic means the pneumatic information given at the coupling interface shall result in a performance equivalent to the above.

4.2.5. Passenger information and communication

4.2.5.1. Public address system

Clauses 4.2.2.8.1 and 4.2.2.8.3 of the TSI for Accessibility for Persons with Reduced Mobility shall also apply.

Trains shall be equipped as a minimum with a means of audible communication,

- for the train crew to address the passengers in a train
- for the train crew and ground control to communicate between one another.
- for internal communication between the train crew and in particular between the driver and staff in the passenger areas.

The equipment shall be able to remain on standby and to function independently of the main energy source for at least three hours.

The communication system shall be designed in such a manner that it continues to operate at least half (distributed throughout the train) of its loudspeakers in the event of a failure in one of its transmission elements, or another mean shall be available to inform the passengers.

Apart from the passenger alarm (see clause 4.2.5.3) no specific provisions are prescribed for passengers to contact train crew.

4.2.5.2. Passenger information signs

Clause 4.2.2.8.2 of the of the TSI for Accessibility for Persons with Reduced Mobility shall also apply.

All passenger signs closely connected with safety shall use the unified sign formats given in standard ISO 3864-1:2002.

4.2.5.3. Passenger alarm

Passenger occupied areas on trains (excluding vestibules, gangways and toilets) shall be fitted with emergency signal devices. These devices shall be installed where they can be seen easily by passengers and reached by them without having to pass through an interior door.

The emergency handle shall have a clearly visible seal.

The alarm once activated shall not be capable of being disengaged by passengers. If a device is provided to indicate that the alarm has been activated, it shall be marked as indicated in Annex Q of this TSI.

Operation of the emergency signal shall be indicated next to the device used.

Activating the alarm shall:

- Initiate braking
- Cause a visual (flashing or continuous light) and acoustic (buzzer/klaxon or spoken message) alarm to be triggered in the driver's cab;
- Transmit a message (acoustic or visual signal or radio message by mobile phone) by the driver or an automatic system to the train crew working among the passengers.
- Transmit an acknowledgement, recognisable by the person who triggered the signal (acoustic signal in the vehicle, braking application, etc.)

The arrangements installed in the rolling stock (automatic brake application, in particular) shall allow the driver to intervene in the braking process so as to be able to choose the stopping point of the train.

When the train has stopped the driver shall be able to start again as soon as possible if the driver considers it safe to start again. Activation of one or more than one alarm shall have no additional effect, whilst the train-crew has not rearmed the first.

Lastly a communication link between cab and train staff shall enable the driver, at his or her initiative, to investigate the reasons why the emergency signal was triggered. If in normal service no train staff is present a device shall be available for passengers to communicate to the driver in case of emergency.

4.2.6. Environmental conditions

4.2.6.1. Environmental conditions

The rolling stock and all its constituent parts shall meet the requirements of this TSI within the climatic zones T1, or T2, or T3 as specified in EN50125-1:1999 in which it is intended to run. These zones shall be indicated in the rolling stock register.

4.2.6.2. Train aerodynamic loads in open air

4.2.6.2.1. Aerodynamic loads on track workers at the lineside

A full length train running in the open air at 300 km/h or at its maximum operating speed $v_{tr,max}$ if lower than 300 km/h shall not cause an exceedance of the air speed $u_{2\sigma}$ at the trackside as set out in Table 9, at a height of 0,2 m above the top of rail and at a distance of 3,0 m from the track centre, during the passage of the whole train (including the wake).

For trains with a maximum speed higher than 300 km/h, the the measures to be taken by Infrastructure Manager are mentioned in clause 4.4.3 of the High Speed Infrastructure TSI.

Table 9

Trackside maximum permissible air speed

Maximum train speed $v_{tr,max}$ (km/h)	Trackside maximum permissible air speed, (limit values for $u_{2\sigma}$ (m/s))
From 190 to 249	20
From 250 to 300	22

Test conditions

Tests shall be undertaken on ballasted, straight track. The vertical distance between the top of rail and the surrounding ground level is $0,75m \pm 0,25m$. The value $u_{2\sigma}$ is the upper bound of the 2σ confidence interval of the maximum resultant induced air speeds in the x-y ground plane. It shall be obtained from at least 20 independent and comparable test samples with ambient wind speeds of less than or equal to 2 m/s.

$u_{2\sigma}$ is given by:

$$u_{2\sigma} = \bar{u} + 2\sigma$$

with

\bar{u} mean value of all air speed measurements u_i , $i \geq 20$

σ standard deviation

Conformity assessment

Conformity shall be assessed on the basis of full-scale tests and with the maximum length of the defined formations.

Detailed specifications

Measurements shall be taken at the maximum operational speed of the train $v_{tr,max}$ or 300 km/h if the train maximum operating speed is higher than 300 km/h.

For a valid set of measurements, conditions for train speed v_{tr} are:

- at least 50 % of the measurements shall be within ± 5 % of $v_{tr,max}$ or 300 km/h as applicable and
- 100 % of the measurements shall be within ± 10 % of $v_{tr,max}$ or 300 km/h as applicable.

Each measurement $u_{measured,i}$ shall be corrected by

$$u_i = u_{measured,i} * v_{tr}/v_{tr,i}$$

The track shall have no obstacles, such as bridges or tunnels, nearer than 500m ahead and 100m after the sensors in the longitudinal direction. Groups of sensors are permitted to be used to obtain several independent measurements from one train passage. Such groups shall be spaced at least 20 m apart from each other.

The whole train-passing event shall consist of the time period starting 1 second before the passing of the train head and finishing 10 seconds after the tail passes.

The sampling rate of the sensor shall be at least 10 Hz. The signal shall be filtered using a 1 second window moving average filter. The ambient wind speed shall be determined at the first sensor at a height of 0,2 m above top of rail.

The ambient wind speed is equivalent to the mean wind speed in the 3-second interval occurring before the train head passes the wind sensor. The ambient wind speed shall be less than or equal to 2 m/s.

The uncertainty in the air speed measurements shall be determined and shall not exceed ± 3 %.

The uncertainty in the train speed measurement shall be determined and shall not exceed ± 1 %.

4.2.6.2.2. Aerodynamic loads on passengers on a platform

A full length train, running in the open air at a reference speed $v_{tr} = 200$ km/h, (or at its maximum operating speed $v_{tr,max}$, if this is lower than 200 km/h), shall not cause the air speed to exceed value $u_{2,0} = 15,5$ m/s at a height of 1,2 m above the platform and at a distance of 3,0 m from the track centre, during the whole train passage (including the wake).

Test conditions

The assessment shall either be made on a

- platform of height 240 mm above rail level or lower if one is available
- or the applicant shall select the lowest height of platform passed by the train to be used for the assessment.

The platform height used in the assessment shall be recorded in the rolling stock register. If the assessment is successful for a platform height of 240 mm or lower, the train shall be deemed to be acceptable for all lines.

The value $u_{2\sigma}$ is the upper bound of the 2σ confidence interval of the maximum resultant induced air speeds in the x-y platform plane. It shall be based on at least 20 separate measurements and under similar test conditions with ambient wind speeds of less than or equal to 2 m/s.

$u_{2\sigma}$ is given by:

$$u_{2\sigma} = \bar{u} + 2\sigma$$

with

\bar{u} mean value of all air speed measurements u_i , $i \geq 20$

σ standard deviation

Conformity assessment

Conformity shall be assessed on the basis of full-scale tests and with the maximum length of the defined formations.

Detailed specifications

Measurements shall be taken at $v_{tr} = 200$ km/h or, if it is lower, with the maximum operational speed of the train, $v_{tr,max}$.

For a valid set of measurements, conditions for train speed v_{tr} are:

- at least 50 % of the measurements shall be within ± 5 % of $v_{tr,max}$ or 200 km/h as applicable and
- 100 % of the measurements shall be within ± 10 % of $v_{tr,max}$ or 200 km/h as applicable.

Each measurement, $u_{measured,i}$, shall be corrected by

$$u_i = u_{measured,i} * 200 \text{ km/h} / v_{tr,i}$$

or, for $v_{tr,max} < 200$ km/h,

$$u_i = u_{measured,i} * v_{tr,max} / v_{tr,i}$$

The platform shall have no obstacles ahead of and after the sensors in the longitudinal direction. The platform shall have a constant geometry for a distance of 150 m ahead of the sensors in the longitudinal direction and shall not have a roof or canopy or backwall. A number of sensors are permitted to be used to obtain several independent measurements from one train passage. Such sensors shall be separated from each other by a distance of at least 20 m.

The whole train-passing event consists of the time period starting 1 second before the passing of the train head and finishing 10 seconds after the tail passes.

The sampling rate of the sensor shall be at least 10 Hz. The signal shall be filtered using a 1 second window moving average filter.

The wind speed shall be determined by the first sensor on the platform or by a separate wind sensor installed 1,2 m above platform. The ambient wind speed is equivalent to the mean wind speed in the 3-second interval occurring before the train passes the wind sensor. The ambient wind speed shall be less than or equal to 2 m/s.

The uncertainty in the air speed measurements shall be determined and shall not exceed ± 3 %.

The uncertainty in the train speed measurement shall be determined and shall not exceed ± 1 %.

4.2.6.2.3. Pressure loads in open air

A full length train, running at a given speed (reference case) in the open air shall not cause the maximum peak-to-peak pressure of changes to exceed a value $\Delta p_{2\sigma}$ as set out in Table 10 over the range of heights 1,5 m to 3,3 m above the top of rail, and at a distance of 2,5 m from the track centre, during the whole train passage (including the passing of the head, couplings and tail). The maximum peak-to-peak pressure changes are tabulated below:

Table 10

Maximum permissible pressure changes in open air

Train	Reference train speed	Maximum permissible pressure change $\Delta p_{2\sigma}$
Class 1	250 km/h	795 Pa
Class 2	At maximum speed	720 Pa

Conformity assessment

Conformity shall be assessed on the basis of full-scale tests and with a maximum length of the defined formations.

Detailed specifications

Tests shall be undertaken on ballasted, straight track. The vertical distance between the top of rail and the surrounding ground level is $0,75\text{ m} \pm 0,25\text{ m}$. The considered event shall be that of a whole train passing and shall consist of the time period starting 1 second before the passing of the train head and finishing 10 seconds after the train tail passes.

The measurements shall be taken at 1,5 m, 1,8 m, 2,1 m, 2,4 m, 2,7 m, 3,0 m and 3,3 m height above the top of rail and shall be analysed separately for each measuring position. For any position the $\Delta p_{2\sigma}$ -requirement needs to be fulfilled.

The value $\Delta p_{2\sigma}$ shall be the upper bound of a 2σ interval of $(p_{\max} - p_{\min})$ based on at least 10 independent and comparable test samples (at a certain measuring height) with ambient wind speeds of less than or equal to 2 m/s.

$\Delta p_{2\sigma}$ is given by:

$$\Delta p_{2\sigma} = \overline{\Delta p} + 2 \cdot \sigma$$

with

$\overline{\Delta p}$ mean value of all peak-to-peak pressure measurements Δp_i , $i \geq 10$

σ standard deviation

A number of sensors are permitted to be used to obtain several independent measurements from one train passage. Such sensors shall be separated from each other by a distance of at least 20 m.

For a valid set of measurements, conditions for train speed v_{tr} are:

- at least 50 % of the measurements shall be within ± 5 % of the reference train speed and
- 100 % of the measurements shall be within ± 10 % of the reference train speed.

The wind speed and direction shall be determined using a meteorological station installed near to the pressure measurement location, at 2 m above the top of rail and at 4 m distance to the track. The ambient wind speed shall be equivalent to the mean wind speed in the 15 second interval occurring before the train head passes the wind sensor. The ambient wind shall be less than or equal to 2 m/s.

The pressure sensors used shall be capable of measuring the pressure with a minimum of 150 Hz resolution. All pressure sensors shall be connected to the static pressure opening of Prandtl tubes directed in longitudinal x-direction. It is permitted to use a method that is proven to be equivalent.

The uncertainty in the pressure measurements shall be determined and shall not exceed $\pm 2\%$.

The uncertainty in the train speed measurement shall be determined and shall not exceed $\pm 1\%$.

The pressure signal shall be analogue low pass filtered with a 75 Hz 6 pole Butterworth low pass filter or equivalent. For each pressure sensor and run the maximum pressure peak-to-peak value during the whole passage $\Delta p_{m,i}$ shall be computed and then corrected to the investigated train speed v_{tr} and to standard density ρ_0 using the following formula $\Delta p_i = \Delta p_{m,i} \cdot (v_{tr,i} / (v_{tr,i} + v_{w,x,i}))^2 \cdot (\rho_0 / \rho_i)$

with:

- Δp_i : the corrected peak-to-peak pressure change
- $\Delta p_{m,i}$: the measured peak-to-peak pressure change for sample i
- ρ_i : the air density measured at the test site for sample i
- $v_{w,x,i}$: the measured wind speed component in x-direction for sample i
- $v_{tr,i}$: the measured train speed for sample i
- v_{tr} : the investigated train speed
- ρ_0 : the standard density of 1,225 kg/m³

4.2.6.3. Crosswind

A train is deemed to meet the crosswind requirements if its characteristic wind curves (CWC: as defined in Annex G) of its most wind sensitive vehicle are superior or at least equivalent to a set of characteristic reference wind curves (CRWC).

The set of CRWC to assess conformity of rolling stock is given in the Tables 11, 12, 13 and 14 for Class 1 vehicles for which the characteristic wind curves (CWC) shall be calculated according to the method detailed in Annex G.

Limiting values and corresponding methods for Class 1 tilting trains and Class 2 vehicles is an open issue.

Table 11

Reference characteristic wind speeds for angle $\beta_w=90^\circ$ (vehicle on straight track with a lateral uncompensated acceleration: $a_q = 0 \text{ m/s}^2$).

Train speed	Reference characteristic wind speed for the flat ground case (without ballast and rails) in m/s	Reference characteristic wind speed for the embankment case in m/s
120 km/h	38,0	34,1
160 km/h	36,4	31,3
200 km/h	34,8	28,5
250 km/h	32,8	25,0
steps of 50 km/h up to $v_{tr,max}$	see lines below	see lines below

Maximum train speed	Reference characteristic wind speed for the flat ground case (without ballast and rails) in m/s	Reference characteristic wind speed for the embankment case in m/s
$v_{tr,max} = 260$ km/h	32,4	24,5
$v_{tr,max} = 270$ km/h	32,0	24,0
$v_{tr,max} = 280$ km/h	31,6	23,5
$v_{tr,max} = 290$ km/h	31,2	23,0
$v_{tr,max} = 300$ km/h	30,8	22,5
$v_{tr,max} = 310$ km/h	30,4	22,0
$v_{tr,max} = 320$ km/h	30,0	21,5
$v_{tr,max} = 330$ km/h	29,6	21,0
$v_{tr,max} = 340$ km/h	29,2	20,5
$v_{tr,max} = 350$ km/h	28,8	20,0

As an example the table shall be used as follows: For a maximum train speed of 330 km/h, the CWC values shall be assessed at the following speeds 120 km/h, 160 km/h, 200 km/h, 250 km/h, 300 km/h and 330 km/h.

Table 12

Reference characteristic wind speeds for angle $\beta_w = 90^\circ$ (vehicle in a curve with $a_q = 0,5$ m/s² and with $a_q = 1,0$ m/s²).

Train speed	Reference characteristic wind speed for the flat ground case (without ballast and rails) in m/s for lateral acceleration $a_q = 0,5$ m/s ²	Reference characteristic wind speed for the flat ground case (without ballast and rails) in m/s for lateral acceleration $a_q = 1,0$ m/s ²
250 km/h	29,5	26,0
steps of 50 km/h up to $v_{tr,max}$	see lines below	see lines below
Maximum train speed	Reference characteristic wind speed for the flat ground case (without ballast and rails) in m/s for lateral acceleration $a_q = 0,5$ m/s ²	Reference characteristic wind speed for the flat ground case (without ballast and rails) in m/s for lateral acceleration $a_q = 1,0$ m/s ²
$v_{tr,max} = 260$ km/h	29,1	25,6
$v_{tr,max} = 270$ km/h	28,7	25,2
$v_{tr,max} = 280$ km/h	28,3	24,8
$v_{tr,max} = 290$ km/h	27,9	24,4
$v_{tr,max} = 300$ km/h	27,5	24,0
$v_{tr,max} = 310$ km/h	27,1	23,6
$v_{tr,max} = 320$ km/h	26,7	23,2
$v_{tr,max} = 330$ km/h	26,3	22,8
$v_{tr,max} = 340$ km/h	25,9	22,4
$v_{tr,max} = 350$ km/h	25,5	22,0

Table 13

**Reference Characteristic wind speeds for $v_{tr} = v_{tr,max}$
(vehicle on flat ground without ballast and rails on straight track).**

Considered max. train speed	Reference characteristic wind speed in m/s for angle β_w							
	80°	70°	60°	50°	40°	30°	20°	10°
$v_{tr,max} = 250$ km/h	32,5	33,2	35,0	38,2	43,6	45	45	—
$v_{tr,max} = 260$ km/h	32,1	32,8	34,5	37,7	43,0	45	45	—
$v_{tr,max} = 270$ km/h	31,7	32,4	34,1	37,3	42,5	45	45	—
$v_{tr,max} = 280$ km/h	31,3	32,0	33,7	36,8	42,0	45	45	—
$v_{tr,max} = 290$ km/h	30,9	31,5	33,3	36,3	41,4	45	45	—
$v_{tr,max} = 300$ km/h	30,5	31,1	32,8	35,9	40,9	45	45	—
$v_{tr,max} = 310$ km/h	30,1	30,7	32,4	35,4	40,4	45	45	—
$v_{tr,max} = 320$ km/h	29,7	30,3	32,0	34,9	39,8	45	45	—
$v_{tr,max} = 330$ km/h	29,3	29,9	31,6	34,5	39,3	45	45	—
$v_{tr,max} = 340$ km/h	28,9	29,5	31,1	34,0	38,8	45	45	—
$v_{tr,max} = 350$ km/h	28,5	29,1	30,7	33,5	38,2	45	45	—

Table 14

**Reference characteristic wind speeds for $v_{tr} = v_{tr,max}$
(vehicle on a 6m embankment on straight track).**

Considered max. train speed	Reference characteristic wind speed in m/s for angle β_w							
	80°	70°	60°	50°	40°	30°	20°	10°
$v_{tr,max} = 250$ km/h	24,6	25,0	26,1	28,4	32,0	38,1	45	45
$v_{tr,max} = 260$ km/h	24,1	24,5	25,6	27,8	31,4	37,4	45	45
$v_{tr,max} = 270$ km/h	23,6	24,0	25,1	27,2	30,7	36,6	45	45
$v_{tr,max} = 280$ km/h	23,1	23,5	24,6	26,7	30,1	35,8	45	45
$v_{tr,max} = 290$ km/h	22,6	23,0	24,1	26,1	29,5	35,1	45	45
$v_{tr,max} = 300$ km/h	22,1	22,5	23,5	25,5	28,8	34,3	45	45
$v_{tr,max} = 310$ km/h	21,7	22,0	23,0	25,0	28,2	33,5	43,0	45
$v_{tr,max} = 320$ km/h	21,2	21,5	22,5	24,4	27,5	32,8	42,1	45
$v_{tr,max} = 330$ km/h	20,7	21,0	22,0	23,8	26,9	32,0	41,1	45
$v_{tr,max} = 340$ km/h	20,2	20,5	21,4	23,2	26,3	31,3	40,1	45
$v_{tr,max} = 350$ km/h	19,7	20,0	20,9	22,7	25,6	30,5	39,1	45

Superiority or equivalence to the reference curves is given if all the CWC-points relevant for the comparison are equal to or higher than the corresponding ones of the reference set.

4.2.6.4. Maximum pressure variations in tunnels

Rolling stock shall be aerodynamically designed so that for a given combination (reference case) of train speed and tunnel cross section in case of a solo run in a simple, non-inclined tube-like tunnel (without any shafts etc.) a requirement for the characteristic pressure variation shall be met. The requirements are given in the Table 15.

Table 15

Requirements for interoperable train in a solo-run in a non-inclined tube-like tunnel.

Train Type	Reference Case		Criteria for the Reference Case		
	v_{tr} [km/h]	A_{tu} [m ²]	Δp_N [Pa]	$\Delta p_N + \Delta p_{Fr}$ [Pa]	$\Delta p_N + \Delta p_{Fr} + \Delta p_T$ [Pa]
$v_{tr,max} < 250$ km/h	200	53,6	$\leq 1\,750$	$\leq 3\,000$	$\leq 3\,700$
$v_{tr,max} \geq 250$ km/h	250	63,0	$\leq 1\,600$	$\leq 3\,000$	$\leq 4\,100$

Where v_{tr} is the train speed and A_{tu} is the tunnel cross sectional area.

Conformity shall be proven on the basis of full-scale tests, carried out at reference speed or at a higher speed in a tunnel with a cross-sectional area as close to the reference case as possible. Transfer to the reference condition shall be done with validated simulation software.

When assessing conformity of whole trains or trainsets, assessment shall be made with the maximum length of the train or coupled trainsets up to 400 m.

When assessing conformity of locomotives or driving coaches, assessment shall be done on a basis of two arbitrary train compositions of minimum length 150 m, one with a leading locomotive or driving coach (to check the Δp_N) and one with a locomotive or a driving coach at the end (to check Δp_T). Δp_{Fr} is set to 1250 Pa (for trains with $v_{tr,max} < 250$ km/h) or to 1400 Pa (for trains with $v_{tr,max} \geq 250$ km/h).

When assessing conformity of coaches only, assessment shall be done on the basis of one 400 m long train. Δp_N is set to 1750 Pa and Δp_T to 700 Pa (for trains with $v_{tr,max} < 250$ km/h) or to 1600 Pa and 1100 Pa (for trains with $v_{tr,max} \geq 250$ km/h).

For the distance x_p between the entrance portal and the measuring position, the definitions of Δp_{Fr} , Δp_N , Δp_T , the minimum tunnel length and further information about the derivation of the characteristic pressure variation see EN14067-5:2006.

4.2.6.5. Exterior noise

4.2.6.5.1. Introduction

Noise emitted by rolling stock subdivides into stationary noise, starting noise, and pass-by noise.

The stationary noise is highly influenced by auxiliaries, such as cooling systems, air conditioning and compressors.

Starting noise is a combination of contributions from traction components such as diesel engines and cooling fans, auxiliaries and, sometimes, wheel slip.

Pass-by noise is highly influenced by the rolling noise, linked to the wheel/rail interaction, which is a function of speed, and at higher speeds, by aerodynamic noise.

The rolling noise itself is caused by the combined wheel and rail roughness and by the dynamic behaviour of the track and wheelset.

In addition to the rolling noise, at low speed, the noise of auxiliaries and traction equipment is also significant.

The emitted level of noise is characterised by:

- Sound pressure level (measured by a specified method, including specified microphone position),
- Speed of the rolling stock,

- Rail roughness,
- Dynamic and sound radiation behaviour of the track.

The parameters set for the characterisation of stationary noise comprise:

- Sound pressure level, (measured by a specified method, including specified microphone position),
- Operating conditions.

4.2.6.5.2. Limits for stationary noise

The limits for stationary noise are defined at a distance of 7,5 m from the centreline of the track, 1,2 m above the upper surface of the rails. The vehicles under test shall be in service retention mode; that is rheostatic ventilation off and air brake compressor off, HVAC normal (not preconditioning mode) and all other equipment in normal operating condition. The measuring conditions are defined by the standard EN ISO 3095:2005 with the deviations defined in Annex N of this TSI. The parameter for the sound pressure level is $L_{pAeq,T}$. The limiting values for the noise emission of the vehicles under the conditions mentioned above are given in Table 16.

Table 16

Limiting values $L_{pAeq,T}$ for the stationary noise of rolling stock. The specified level for stationary noise is the energy-average of all measured values taken at the measuring points defined in Annex N 1.1 of this TSI.

Vehicles	$L_{pAeq,T}$ [dB(A)]	
	Class 1	Class 2
Electric locomotives		75
Diesel locomotives		75
Electric trainsets	68	68
Diesel trainsets		73
Passenger coaches		65

4.2.6.5.3. Limits for starting noise

The limits for starting noise are defined at a distance of 7,5 m from the centreline of the track, 1,2 m above the upper surface of the rails. The measuring conditions are defined by the standard EN ISO 3095:2005 with the deviations defined in **Annex N1.2**. The indicator for the sound level is L_{pAFmax} . The limiting values for the starting noise of the vehicles under the conditions stated above are given in Table 17.

Table 17

Limiting values L_{pAFmax} for the starting noise of rolling stock

Vehicles	L_{pAFmax} [dB(A)]
Electric locomotives	85
$P \geq 4\ 500$ kW at the wheel rim	
Electric locomotives	82
$P < 4\ 500$ kW at the wheel rim	
Diesel locomotives	89
Class 2 Electric trainsets	82
Class 1 Electric trainsets	85
Diesel trainsets	85

4.2.6.5.4. Limits for pass-by noise

The limits for pass-by noise are defined at a distance of 25 m from the centreline of the reference track, 3,5 m above the upper surface of the rails for a vehicle speed indicated in Table 18 below. The indicator for the A weighted equivalent continuous sound level is $L_{pAeq,TP}$.

The measurements shall be carried out in accordance with EN ISO 3095:2005 with deviations stated in Annex N1.3 and N1.4.

The test train shall consist of:

- In the case of a trainset, the trainset itself
- In the case of locomotive, the locomotive to be tested plus four coaches. The pass-by noise of these four coaches $L_{pAeq,TP}$ measured at 7,5 m from the track centre 1,2 m above the top of rail and at 200 km/h on the reference track shall not exceed 92 dB (A). Alternatively two locomotives of the same type and 8 coaches are permitted to be used in any configuration
- In the case of coaches, the four coaches to be tested plus one locomotive. The pass-by noise of the locomotive $L_{pAeq,TP}$ measured at 7,5 m from the track centre 1,2 m above the top of rail and at 200 km/h on the reference track shall not exceed 97 dB (A). Alternatively two locomotives of the same type and 8 coaches are permitted to be used in any configuration.

The two latter cases are defined as a 'variable formation' in this section.

The limiting values for the noise emission of the full test train $L_{pAeq,TP}$ at 25 m 3,5 m above top of rail are given in Table 18.

Table 18

Limiting values $L_{pAeq,TP}$ for the pass-by noise of rolling stock

Rolling stock		Speed [km/h]			
		200	250	300	320
Class 1	Trainset		87 dB(A)	91 dB(A)	92 dB(A)
Class 2	Trainset or variable formations	88 dB(A)			

A margin of 1 dB(A) is accepted on the values given in table 18

4.2.6.6. Exterior electromagnetic interference

For trains, with all forms of traction, the generation and distribution of electrical energy causes interference of high or low intensity by conduction (e.g. through the catenary and rail) and by electromagnetic radiation. In addition, on-board equipment can cause interference.

4.2.6.6.1. Interference generated on the signalling system and the telecommunications network:

Open point

4.2.6.6.2. Electromagnetic interference:

In order to avoid degrading the proper operation of rolling stock due to electromagnetic interference, the requirements of the following standards shall be met:

- EN 50121-3-1:2000 for the total rolling stock subsystem,
- EN 50121-3-2:2000 for the different kinds of on-board equipment susceptible to interference.

4.2.7. System protection

4.2.7.1. Emergency exits

4.2.7.1.1. Passengers' emergency exits

A. Arrangement

Emergency exits shall conform to the following rules:

- The distance between each passenger seat and an emergency exit shall always be less than 16 m.
- There shall be a minimum of two emergency exits in each vehicle accommodating 40 passengers or less. There shall be three or more in each vehicle accommodating more than 40 passengers. It is not permitted to place all the emergency exits exclusively on one side of the vehicle.
- The minimum dimensions of the opening through the emergency exits shall be 700 mm x 550 mm. It is permissible to position seats in this area.

B. Operation

External access doors shall be used as emergency exits as a priority. If this is not possible, it shall be possible to use the following as emergency routes either separately or in combination:

- designated windows, by ejection of the window or glazing or by breaking the glass,
- compartment and gangway doors, by rapid removal of the door or breaking the glass,
- external access doors, by ejecting them or breaking the glass.

C. Signage

Emergency exits shall be clearly identified to passengers and rescue teams by means of suitable signs.

D. Evacuation via the doors

Trains shall be equipped with emergency devices (emergency steps or ladders) allowing the evacuation of passengers via access doors when not present at a platform

4.2.7.1.2. Driver's cab emergency exits

In an emergency, evacuation from the driver's cab (or access to the interior of the train by the emergency services) shall normally be by means of the access doors specified in clause 4.2.2.6.a.

Where the doors do not give direct external access, each driver's cab shall be provided with an appropriate means of evacuation through the side windows or through the trap doors, on both sides of the cab. These emergency exits shall each have minimum dimensions of 500 mm by 400 mm to allow for the release of trapped persons.

4.2.7.2. Fire safety

For the purpose of this clause the following definitions apply:

Electrical supply line: The line between the current collector or current source and the main circuit breaker or the main fuse(s) on the vehicle.

Traction circuit equipment: Both the traction module as defined in clause 4.2.8.1 and the power equipment feeding the traction module from the electrical supply line

4.2.7.2.1. Introduction

This section states requirements to prevent, detect and limit the effects of a train fire.

Two categories are defined in this section, Category A and Category B, defined as follows:

category A Fire safety:

Category A Fire safety rolling stock is designed and built to operate on infrastructure with tunnels and/or elevated sections of maximum length of 5km. Successive tunnels are not considered as one tunnel if both of the two following requirements are fulfilled:

- the separation between them in open air is longer than 500 m
- there is an access/egress facility to a safe area within the open section

category B Fire safety

Category B Fire safety rolling stock is designed and built to operate on all infrastructures (including those with tunnels and/or elevated sections with lengths exceeding 5 km).

For category B fire safety rolling stock additional measures set out in clauses 4.2.7.2.3.3 and 4.2.7.2.4 are required to improve the probability that a train will continue to operate in the event that a fire is detected as it enters a tunnel. These measures are intended to enable a train to reach a suitable place to stop and allow passengers and staff to be evacuated from the train to a place of safety.

There are no additional requirements for rolling stock relating to tunnels longer than 20 km because these tunnels are specially equipped to be safe for trains compliant with this TSI. Details remain an open point in the High Speed Infrastructure TSI 2006.

4.2.7.2.2. Measures to prevent fire

Materials and components selection shall take into account their fire behaviour properties.

Design measures shall be implemented in order to prevent ignition.

The conformity requirements are addressed in Clause 7.1.6

4.2.7.2.3. Measures to detect/control fire

4.2.7.2.3.1. Fire detection

The high fire risk areas on rolling stock shall be equipped with a system that can detect fire in an early stage and that can initiate appropriate automatic actions to minimize the subsequent risk to passengers and train staff.

This requirement shall be deemed to be satisfied by the verification of conformity to the following requirements:

- The rolling stock shall be equipped with a fire detection system that can detect a fire in an early stage in the following areas:
 - technical compartment or cabinet, sealed or not sealed, containing electrical supply line and/or traction circuit equipment
 - technical area with a combustion engine
 - in sleeping cars, sleeping compartments, staff compartments and gangways and their adjacent combustion heating equipment

- Upon activation of the detection system of a technical area, the following automatic actions shall be required:
 - notification to the train driver
 - shut down of forced ventilation and high voltage energy/fuel supply to the affected equipment that could cause the fire to develop
- Upon activation of the detection system of a sleeping compartment, the following automatic actions shall be required:
 - notification to the train driver and the train manager responsible for the affected area
 - for the sleeping compartment — activation of an acoustic local alarm in the affected area that is sufficient to wake the passengers

4.2.7.2.3.2. Fire extinguisher

The rolling stock shall be equipped with adequate and sufficient portable water plus additive type fire extinguishers in accordance with the requirements of EN3-3:1994; EN3-6:1999; and EN3-7:2004 at appropriate locations.

4.2.7.2.3.3. Fire resistance

For category B fire safety, the rolling stock shall be equipped with adequate fire barriers and partitions at appropriate locations.

The conformity with this requirement shall be deemed to be satisfied by the verification of conformity to the following requirements:

- The rolling stock shall be equipped with full cross section partitions within passenger/staff areas of each vehicle, with a maximum separation of 28m which shall satisfy requirements for integrity for a minimum of 15 minutes. (Assuming the fire can start from either side of the partition)
- The rolling stock shall be equipped with fire barriers that shall satisfy requirements for integrity and heat insulation for a minimum of 15 minutes.
 - Between the drivers cab and the compartment to the rear of it (assuming the fire starts in the rear compartment).
 - Between combustion engine and adjacent passenger/staff areas. (Assuming the fire starts in the combustion engine)
 - Between compartments with electrical supply line and/or traction circuit equipment and passenger/staff area. (Assuming the fire starts in the electrical supply line and/or the traction circuit equipment)

The test shall be carried out in accordance with the requirements of EN 1363-1:1999 partition test.

4.2.7.2.4. Additional measures to improve running capability

4.2.7.2.4.1. Trains of all categories of fire safety

These measures are applicable to rolling stock designated as category A or B fire safety of this TSI.

These measures are required to improve the probability that a train will continue to operate for 4 minutes in the event that a fire is detected as the train enters a tunnel section. This requirement is made so that the train will reach a suitable place to stop and allow passengers and staff to be evacuated from the train to a place of safety.

This requirement shall be deemed to be satisfied by a failure mode analysis relating to the following requirement:

The brakes shall not automatically apply to bring the train to a halt as a result of system failure caused by a fire assuming the fire is in a technical compartment or cabinet, sealed or unsealed, containing electrical supply line and/or traction circuit equipment or a technical area with a combustion engine.

4.2.7.2.4.2. Category B fire safety

These measures are applicable to rolling stock designated as category B fire safety only of this TSI.

These measures are required to improve the probability that a train will continue to operate for 15 minutes in the event that a fire is detected as the train enters a tunnel. This requirement is made so that the train will reach a suitable place to stop and allow passengers and staff to be evacuated from the train to a place of safety.

This requirement shall be deemed to be satisfied by a failure mode analysis relating to the following requirements:

- Brakes — The brakes shall not automatically apply to bring the train to a halt as a result of system failure caused by a fire assuming the fire is in a technical compartment or cabinet, sealed or unsealed, containing electrical supply line and/or traction circuit equipment or a technical area with a combustion engine.
- Traction — 50 % minimum traction redundancy as defined in clause 4.2.8.1 shall be available in degraded mode running capability, assuming the source of the fire is in a technical compartment/cabinet, sealed or unsealed, with electrical supply line and/or traction circuit equipment or a technical area with a combustion engine. If this redundancy requirement cannot be satisfied for reason of traction equipment architecture (e. g. traction equipment in one single place of the train), an automatic fire extinguishing system shall be provided in the locations described in this bullet point.

4.2.7.2.5. Specific measures for tanks containing flammable liquids

4.2.7.2.5.1. General

Transformer tanks are included only if they contain flammable liquids

Where partition walls divide tanks internally, the complete tank shall fulfil the requirements.

Tanks shall be built, located or protected so that they or their piping cannot be punctured or fractured by debris thrown up from the track. Tanks shall not be installed in

- crash energy absorption zones;
- passenger seating areas and areas of temporary occupation by passengers;
- luggage compartments;
- drivers cabs.

Tanks constructed to the following requirements are deemed to satisfy the minimum impact performance.

If other materials are used, equivalent safety shall be demonstrated.

The thickness of walls of tanks for flammable liquids shall have a minimum of:

Volume	Steel	Aluminium
≤ 2 000 l	2,0 mm	3,0 mm
> 2 000 l	3,0 mm	4,0 mm

The temperature of the flammable liquid in the tank shall remain below its flash point according to EN ISO 2719 under all normal operating conditions.

The design of flammable liquid tanks shall ensure, as far as reasonably practicable, that during filling or draining or in the event of leakage from a tank or its pipe work, flammable liquids cannot:

- come into contact with rotating machinery which might result in a spray;
- be drawn into any device in suction e.g. ventilators, coolers etc.;
- come into contact with hot components or electrical devices, which may produce electrical spark;
- penetrate into layers of thermal and acoustic insulation material.

4.2.7.2.5.2. Specific requirements for fuel tanks

Filling limit indicators shall be provided that indicate 90 % of the nominal fuel tank volume.

The output from the limit indicator device shall be easily understandable from the filler position.

It shall be ensured that flammable liquid cannot escape from filler pipes or other openings under normal banking (cant) conditions.

To avoid confusion the kind of appropriate flammable liquid shall be clearly labelled at the filling pipe of the fuel tank. The labelling of the flammable liquid shall be given textual in accordance to safety data sheets according ISO 11014-1. The following danger signs shall be displayed in the vicinity of the filling pipe:

Danger sign according Directive 92/58/EEC

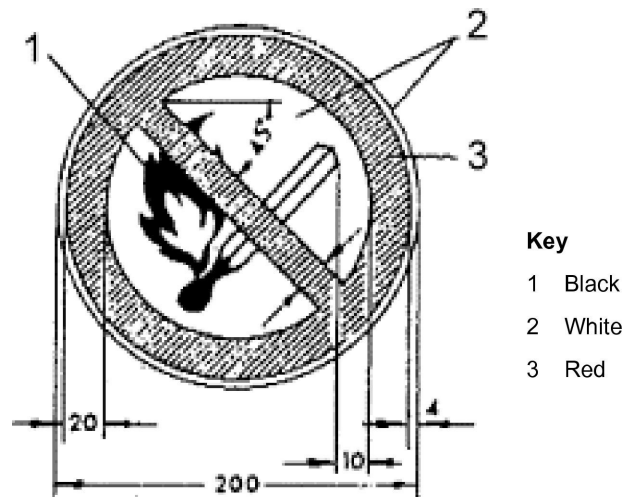

Or danger sign according Directive 92/58/EEC

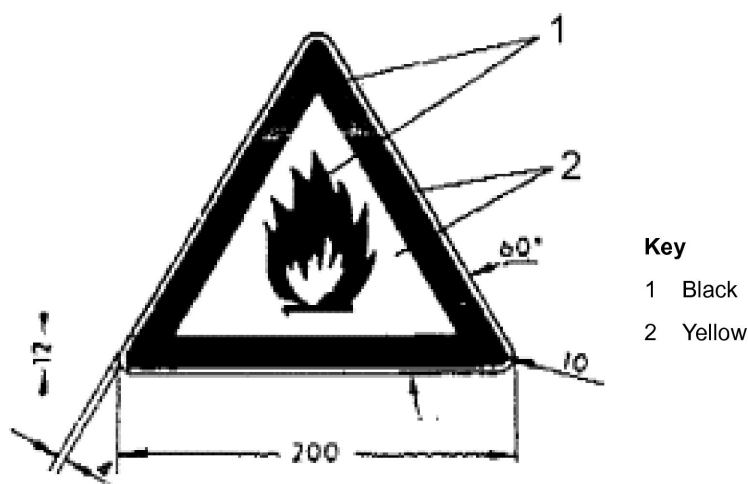

4.2.7.3. Protection against electric shock

Electrically live components shall be designed such that conscious and unconscious contact with train staff and passengers is prevented, in normal operation and in case of equipment failure.

All trains shall be equipped with appropriate tools to earth the vehicles. The driver's manual, kept on the train, and the maintenance manual shall describe their use.

Rolling stock shall comply with the requirements of EN 50153: 2002.

Rolling stock shall comply with the provisions of Annex O of this TSI for earthing protection.

4.2.7.4. External lights and horn

4.2.7.4.1. Front and rear lights

4.2.7.4.1.1. Head lights

Two white head lamps shall be provided at the front end of the train, arranged on the horizontal axis at the same height above the rail level, symmetrical about the centre line, and at a minimum of 1 300 mm apart. Where the presence of a tapered nose cone means 1 300 mm is not achievable it is permissible to reduce this dimension to 1 000 mm

Headlamps shall be mounted between 1 500 and 2 000 mm above the rail level.

The headlamps shall be installed on the vehicle such that the vertical illuminance at a distance of greater than or equal to 100 m is less than 0,5 lux at rail level.

Requirements on headlamps as interoperability constituents are defined in clause H.2 of Annex H.

4.2.7.4.1.2. Marker lights

Three white marker lamps shall be provided at the front end of the train. Two marker lamps shall be arranged on the horizontal axis at the same height above the rail level, symmetrical about the centre line, and at a minimum of 1 300 mm apart. Where the presence of a tapered nose cone means 1 300 mm is not achievable it is permissible to reduce this dimension to 1 000 mm. The third marker lamp shall be arranged centrally above the two lower lamps.

The two lower marker lamps shall be mounted between 1 500 and 2 000 mm above the rail level.

Requirements on marker lamps as interoperability constituents are defined in clause H.2 of Annex H.

4.2.7.4.1.3. Tail lights

Two red tail lamps shall be provided at the rear end of the train, arranged on the horizontal axis at the same height above the rail level, symmetrical about the centre line, and at a minimum of 1 300 mm apart. Where the presence of a tapered nose cone means 1 300 mm is not achievable it is permissible to reduce this dimension to 1 000 mm

Tail lamps shall be mounted between 1 500 and 2 000 mm above the rail level.

Requirements on tail lamps as interoperability constituents are defined in clause H.3 of Annex H.

4.2.7.4.1.4. Lamp controls

A driver shall be able to control the head and marker lamps from the normal driving position. The following functions shall be provided:

- (i) All lamps off
- (ii) Dimmed marker lamps on (daytime and night-time use for bad weather conditions)
- (iii) Full marker lamps on (daytime and nighttime use in normal weather conditions)
- (iv) Dimmed headlamps on (daytime and nighttime by driver's choice;)
- (v) Full-beam headlamps on (daytime and nighttime by driver's choice. Dimmed headlamps shall be used when passing trains, intersecting roads, and passing stations.)

The tail lamps at the rear end of the train shall be automatically switched on when function ii), iii), iv) or v) above is selected. This requirement shall not be applicable for variable formations.

The external lamps located at intermediate points within the train shall be switched off.

In addition to their traditional role as the front and rear lamps, it is permissible in emergency to use the lamps in specific ways and arrangements.

4.2.7.4.2. Horns

4.2.7.4.2.1. General

Trains shall be fitted with horns with two distinct tones. The notes of the audible warning horns are intended to be recognisable as being from a train and not be similar to warning devices used in road transport or as factory or other common warning devices. The acceptable Warning Horn notes shall be either:

- (a) Two separately sounded warning horns. The fundamental frequencies of the warning horn notes shall be:

high note: 370 Hz ± 20 Hz

low note: 311 Hz ± 20 Hz

or

- (b) Two warning horns sounded together as a chord (for the high note). The fundamental frequencies of the chord notes shall be:

high note: 622 Hz ± 30 Hz

low note: 370 Hz ± 20 Hz

or

- (c) Two warning horns sounded together as a chord (for the high note). The fundamental frequencies of the chord notes shall be:

high note: 470 Hz \pm 25 Hz

low note: 370 Hz \pm 20 Hz

or

- (d) Three warning horns sounded together as a chord (for the high note). The fundamental frequencies of the chord notes shall be:

high note: 622 Hz \pm 30 Hz

middle note: 470 Hz \pm 25 Hz

low note: 370 Hz \pm 20 Hz

4.2.7.4.2.2. Warning horn sound pressure levels

The A or C weighted sound pressure level produced by each horn sounded separately (or in a group if designed to sound simultaneously as a chord) shall be between 115dB and 123 dB when measured and verified in accordance with the method defined below. The 115dB sound pressure level shall be achieved when the system air pressure is at 5 bar and the 123dB sound pressure level shall not be exceeded when the system air pressure is at 9 bar.

4.2.7.4.2.3. Protection

Warning horns and their control systems shall be protected, so far as is practicable, from impact and subsequent blockage by airborne objects such as debris, dust, snow, hail or birds.

4.2.7.4.2.4. Verification of sound pressure levels

Sound pressure levels shall be measured 5 metres from the front of the train at the same height as the horn and over a ground covering of new, clean ballast.

Noise measurements of warning horns shall be carried out at an open site which generally meets the requirements of figure 2, where:

D = 5m.

R \geq 1,3 D = 6,5m.

Figure 2

Open site for warning horn measurements

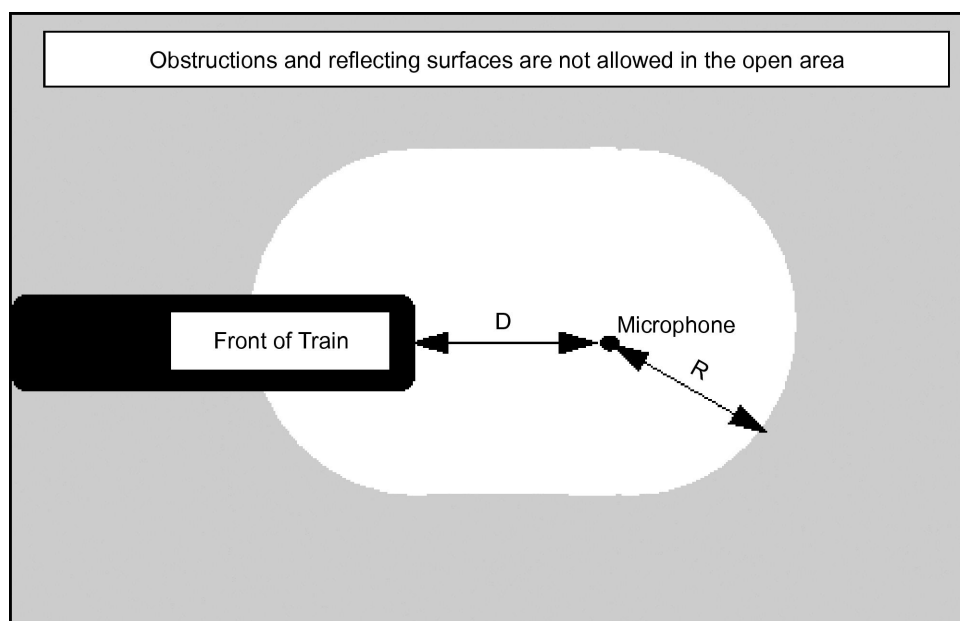

For pneumatic horns, noise measurements shall be carried out when the air pressure in the main reservoir is at 5 bar and 9 bar.

In order to minimise environmental impact it is advisable that the C weighted sound pressure level when measured 5 metres from the side of the train, at the same height as the horn, in line with the front of the horn is at least 5dB lower than the level measured in front of the train.

4.2.7.4.2.5. Interoperability constituent requirements

The fundamental frequencies of the notes of the horns shall be either:

622 Hz \pm 30 Hz

or

470 Hz \pm 25 Hz

or

370 Hz \pm 20 Hz

or

311 Hz \pm 20 Hz

4.2.7.5. Lifting/rescue procedures

The train manufacturer shall provide the relevant technical information to the railway undertaking.

4.2.7.6. Interior noise

The interior noise level of passenger vehicles is not considered to be a Basic Parameter and is not therefore the subject of this TSI.

The noise level within the driver's cab is the subject of Directive 2003/10/EC of the European Parliament and the Council of 6 February 2003 on the minimum health and safety requirements regarding the exposure of workers to the risks arising from physical agents (noise) and shall be applied by railway undertakings and their staff. For the EC verification of rolling stock fulfilment of the requirements of this TSI is sufficient. The limiting values are defined in Table 19.

Table 19

Limiting values $L_{pAeq,T}$ for the noise within the driver's cab of rolling stock

Noise within the driver's cab	$L_{pAeq,T}$ [dB(A)]	Measurement time interval [s]
Standstill (during external acoustical warning in accordance with clause 4.2.7.4.	95	3
Maximum speed. (open country without interior and exterior warnings)	80	60

The measurements shall be done under the following conditions:

- the doors and windows shall be closed,
- the hauled loads shall be equal to at least two-thirds of the maximum permissible value,
- For the measurements at maximum speed, the microphone shall be positioned at the height of the driver's ear (in the seated position), at the centre of a horizontal plane extending from the front window-panes to the rear wall of the cab.

- For measurements of the horn's impact, 8 evenly spaced microphone positions around the position of the driver's head with a radius of 25 cm (in the seated position) shall be used, in a horizontal plane. The arithmetic mean of the 8 values shall be assessed against the limit.
- The wheels and track shall be in good running order;
- The maximum speed shall be maintained for at least 90 % of the measurement time.

It is permissible to subdivide the measurement time into several short periods in order to comply with the above-mentioned conditions.

4.2.7.7. Air conditioning

Driving cabs shall be ventilated by a fresh airflow of 30m³/hr per person. It is permitted to interrupt this airflow when running in tunnels providing the carbon dioxide concentration does not exceed 5 000 ppm assuming the initial carbon dioxide concentration lower than 1 000 ppm.

4.2.7.8. Driver's vigilance device

Any lack of driver vigilance shall be detected within 30 to 60 seconds and shall lead, in the absence of driver reaction, to, as a minimum, an automatic full service brake application on the train and a cessation of re-filling of the main brake pipe.

4.2.7.9. Control-command and signalling system

4.2.7.9.1. General

The interface characteristics between the rolling stock and the control-command and signalling subsystem are included in clause 4.2.1.2 of the Control-Command and Signalling TSI 2006. Amongst others the following requirements of this High Speed Rolling Stock TSI are relevant:

- The minimum braking characteristics for the train specified in clause 4.2.4.1;
- Compatibility between the ground-based train detection systems and the rolling stock, specified in clause 4.2.6.6.1;
- Compatibility between the detectors fixed under vehicles and the dynamic clearances of those vehicles specified in clause 4.2.3.1;
- The environmental conditions for the on-board equipment are specified in clause 4.2.6.1
- Electromagnetic compatibility with on-board control-command equipment specified in clause 4.2.6.6.3;
- Train characteristics concerning braking (specified in section 4.2.4), and train length (specified in clause 4.2.3.5);
- Electromagnetic compatibility with the ground-based systems specified in clause 4.2.6.6.2.

In addition, the following functions are directly linked with parameters defined by the control-command and signalling subsystem.

- Operation in particular failure/degraded mode conditions as specified in clause 4.2.2 of the Control-Command and Signalling TSI 2006
- Monitoring to ensure that the train speed is at all times less than or at most equal to the maximum permitted speed in the operating environment.

Information about the characteristics of these interfaces is given in Tables 5.1 A, 5.1 B and 6.1 in the Control-Command and Signalling TSI 2006. In addition, reference to European standards and specifications to be used as part of the assessment procedure for conformity are indicated, for each characteristic, in Annex A of the Control-Command and Signalling TSI 2006.

Position of control-command and signalling system on-board antennae is specified in clauses 4.2.2 and 4.2.5 of the Control-Command and Signalling TSI 2006.

4.2.7.9.2. Wheelset location

The requirements for wheelset location linked to the control-command and signalling subsystem are as follows:

The distance between two consecutive axles of a vehicle shall not exceed the values that are specified in clause 2.1.1 of Annex A Appendix 1 of the Control-Command and Signalling TSI 2006, and shall not be less than the value that is specified in clause 2.1.3 of Annex A Appendix 1 of the Control-Command and Signalling TSI 2006.

The longitudinal distance from the first axle or from the last axle to the nearest end of the vehicle (i.e. nearest end of coupler, buffer or vehicle nose) shall comply with the requirements given in clause 2.1.2 of Annex A Appendix 1 of the Control-Command and Signalling TSI 2006

The distance between the first and the last axle of a vehicle shall not be less than the value that is specified in clause 2.1.4 of Annex A Appendix 1 of the Control-Command and Signalling TSI 2006.

4.2.7.9.3. Wheels

The requirements for wheels linked to control-command and signalling subsystem are specified in clause 2.2 of Annex A Appendix 1 of the Control-Command and Signalling TSI 2006.

Requirements for the ferromagnetic qualities of the wheel material are specified in clause 3.4 of Annex A Appendix 1 of the Control-Command and Signalling TSI 2006.

4.2.7.10. Monitoring and diagnostic concepts

The functions and equipment specified in this TSI and repeated below, shall be monitored by themselves or externally:

- Door operation as specified in clause 4.2.2.4.2.1
- Instability detection, as specified in clause 4.2.3.4.5
- On-board axle box health monitoring, as specified in clause 4.2.3.3.2.1
- Activation of the passenger alarm as specified in clause 4.2.5.3
- Brake system as specified in clause 4.2.4.3
- Derailment detection as specified in clause 4.2.3.4.11
- Fire detection as specified in clause 4.2.7.2.3
- Failure of the driver vigilance device as specified in clause 4.2.7.8
- Control-command and signalling subsystem information as specified in clause 4.2.7.9

This monitoring of the functions and equipment shall be continuous, or at a frequency to ensure reliable detection of failure. For Class 1 trains the system shall also be linked to the on-board diagnosis data recorder to allow traceability. For all classes of trains the recording related requirements for control-command and signalling subsystem as described in the Control-Command and Signalling TSI 2006 are mandatory.

Indication to the driver shall be made of such detection, and shall require reaction by the driver.

Appropriate automatic braking shall be required where a functional failure occurs on the driver vigilance device or on the control-command and signalling subsystem onboard the trains.

4.2.7.11. Particular specification for tunnels

4.2.7.11.1. Passenger and train crew areas equipped with air conditioning

The train crew shall be able to minimise the distribution and inhalation of fumes in the event of a fire. For this purpose it shall be possible to switch off or close all means of external ventilation and switch off air conditioning. It is permissible to trigger these actions by remote control per train, or at the level of a single vehicle.

4.2.7.11.2. Public address system

Requirements for communication systems are specified in clause 4.2.5.1.

4.2.7.12. Emergency lighting system

To provide protection and safety on board in the event of emergency the trains shall be equipped with an emergency lighting system. This system shall provide a suitable lighting level in the passenger and in the service areas, as follows:

- For a minimum Operating time of three hours after the main energy supply has failed,
- Lighting level of at least 5 lux at floor level.

Values for specific areas and testing methods as defined in Clause 5.3 of EN13272:2001 and shall be complied with.

In the event of fire, the emergency lighting system shall continue to sustain at least 50 % of the emergency lighting in the vehicles not affected by fire for a minimum of 20 minutes. This requirement shall be deemed to be fulfilled by a satisfactory failure mode analysis.

4.2.7.13. Software

Software which has an impact on safety related functions shall be developed and assessed in accordance with the requirements of EN50128: 2001 and EN50155:2001/A1:2002.

4.2.7.14. Driver-Machine-Interface (DMI)

The European Traffic Control System display for driving cabs remains an open point.

4.2.7.15. Vehicle identification

Open point

4.2.8. Traction and electrical equipment

4.2.8.1. Traction performance requirements

In order to guarantee proper compatibility with other train operations, the mean minimum accelerations calculated over time on a level track shall be as set out in Table 20.

Table 20

Calculated minimum mean accelerations

	Class 1 accelerations m/s ²	Class 2 accelerations m/s ²
0 to 40 km/h	0,40	0,30
0 to 120 km/h	0,32	0,28
0 to 160 km/h	0,17	0,17

At the maximum service speed and on level track, the train shall still be capable of an acceleration of at least $0,05 \text{ m/s}^2$.

For reasons of availability, traffic flow, and safe clearance of tunnels, trains shall meet all the following conditions:

- Performance shall be achieved with the nominal voltage;
- One failed traction module shall not deprive a train of more than 25 % of its rated output on a Class 1 train and not more than 50 % on a Class 2 train;
- On a Class 1 train a single failure of power equipment feeding the traction modules shall not deprive the train of more than 50 % of its traction power.

A traction module is defined as power electronic equipment feeding one or several traction motors and which is able to operate independently of the others.

Under these conditions it shall be possible for a train under normal load (as defined in clause 4.2.3.2) with one traction module out-of-service to start on the maximum gradient it is likely to encounter with an acceleration of approximately $0,05 \text{ m/s}^2$. It shall be possible to move the train in this condition on the same gradient for ten minutes and to reach 60 km/h.

4.2.8.2. Traction wheel/rail adhesion requirements

- (a) To ensure a high availability of traction, the design of the train and the calculation of its traction performance shall not make use of wheel/rail adhesion exceeding the values given in Table 21.

Table 21

Maximum allowed wheel/rail adhesion for traction performance calculation

At start up and very low speed	30 %
At 100 km/h	27,5 %
At 200 km/h	19 %
At 300 km/h	10 %

Linear interpolation shall be made for intermediate speed values.

These figures are required only for design and calculation purposes and not for assessment of anti-slip systems.

- (b) Traction axles shall be equipped with an anti-slip system. No assessment of this system is required.

4.2.8.3. Functional and technical specification related to the electric power supply

The electrical characteristics of rolling stock which interface with the energy subsystem shall be considered under the following headings:

- The voltage and frequency variations in the power supply,
- The maximum power that can be drawn from the overhead contact line,
- The power factor of the alternating current supply,
- The short over voltages generated by the operation of rolling stock,
- The electromagnetic interference, see clause 4.2.6.6,
- The other functional interfaces quoted in clause 4.2.8.3.7.

4.2.8.3.1. Voltage and frequency of the power supply

4.2.8.3.1.1. Power supply

Trains shall be able to operate within the range of voltages and frequencies as given in clause 4.2.2 of the High Speed Energy TSI 2006 and specified in clause 4 of EN50163:2004.

4.2.8.3.1.2. Energy recuperation

The general conditions for the return of energy to the overhead contact line from regenerative braking are specified in clause 4.2.4.3 of this TSI and in the clause 12.1.1 of EN50388:2005.

Conformity assessment shall be carried out according to the requirements of EN50388:2005, clause 14.7.1.

4.2.8.3.2. Maximum power and maximum current that is permissible to draw from the overhead contact line

The installed power on a high-speed line determines the permissible power consumption of trains. Therefore, current limitation devices shall be installed on board as required in Section 7 of EN50388:2005. Conformity assessment shall be carried out in accordance EN50388:2005, clause 14.3.

For DC systems, the current at standstill shall be limited to the values specified in clause 4.2.20 of the High Speed Energy TSI 2006.

4.2.8.3.3. Power factor

The design data to be used for the power factor is set out in EN50388:2005, Section 6 with the following exception in yards, sidings and depots:

The power factor of the fundamental wave shall be $\geq 0,8$ ⁽¹⁾ under the following conditions:

— the train is hotelling with traction power switched off and all auxiliaries running

and

— the active power being drawn is greater than 200 kW.

Conformity assessment shall be carried out according to the requirements of Section 6 and clause 14.2 of EN50388:2005.

4.2.8.3.4. System energy disturbances

4.2.8.3.4.1. Harmonic characteristics and related over-voltages on the overhead contact line

A traction unit shall not cause unacceptable overvoltages by generating harmonics. A compatibility assessment on the traction unit shall be undertaken in accordance with the requirements of clause 10 of EN50388:2005, that demonstrates that the traction unit does not generate harmonics beyond the defined limits.

4.2.8.3.4.2. Effects of DC content in AC supply

The AC electric traction units shall be designed so that they are immune for small DC current the value of which is specified in clause 4.2.24 of the High-Speed Energy TSI 2006.

4.2.8.3.5. Energy consumption measuring devices

If energy consumption measuring devices are to be installed on board trains, one device shall be used which shall be able to function in all Member States. The specification of this device remains an open point.

⁽¹⁾ Higher power factors than 0,8 will result in better economic performance due to a reduced requirement for fixed equipment provision.

4.2.8.3.6. Rolling stock subsystem requirements linked to pantographs

4.2.8.3.6.1. Pantograph contact force

(a) Requirements for mean contact force

The mean contact force F_m is formed by the static and aerodynamic components of the contact force with dynamic correction. F_m represents a target value to be achieved in order to ensure current collection quality without undue arcing and to limit wear and hazards to contact strips.

The mean contact force is a characteristic of the pantograph for given rolling stock, its position in the train consist and a given vertical extension of the pantograph.

Rolling stock and pantographs fitted on rolling stock shall be designed to exert the mean contact force on the contact wire (at speeds above 80km/h) described in the following figures according to their intended use:

AC systems: Figure 4.2.15.1 of the High-Speed Energy TSI:2006 (Line category I, II and III)

DC systems: Figure 4.2.15.2 of the High-Speed Energy TSI:2006.

In the case of trains with multiple pantographs simultaneously in operation, the contact force F_m for any individual pantograph shall be no higher than the value given by the applicable curve in Figure 4.2.15.1 of the High-Speed Energy TSI:2006 (for AC) or Figure 4.2.15.2 (for DC).

(b) Adjustment of pantograph mean contact force and integration into the Rolling Stock Sub-System

Rolling stock shall permit adjustment of the pantograph to enable it to comply with the requirements specified in this clause.

Conformity assessment shall be carried out in accordance with the High Speed Energy TSI 2006 clause 4.2.16.2.4.

The pantograph shall be designed to be capable of operating with a mean contact force value (F_m) of the target curves as defined in clause 4.2.15 of the High Speed Energy TSI 2006. To ensure that Rolling Stock and its operating pantograph are suitable for its intended lines of operation, assessment of the mean contact force shall include measurements according to the applicants requirements as follows: For every line category as defined in Table 4.2.9 of the High Speed Energy TSI 2006 on which the train is intended to be operated tests shall be undertaken

— at the range of nominal contact wire heights

and

— up to a maximum speed

as applied for by the manufacturer, railway undertaking or their authorised representatives established within the Community, which asks for assessment.

For these tests, the speed shall be increased from 150 km/h to the maximum speed with intermediate steps not greater than 50 km/h each for the maximum and minimum height. The minimum number of speed levels for Class 1 Rolling Stock is 5 steps and for Class 2 Rolling Stock 3 steps. No tests are required for intermediate heights of the same category of line.

The Rolling Stock Register shall state the maximum successfully tested operating speed for the Rolling Stock/Pantograph combination for each of the line categories and for the range of heights of the OCL for this line and therefore define the operating range Rolling Stock.

Every Member State shall notify relevant Reference Lines on which assessment can be accomplished. Where available, High Speed Energy TSI 2006 compliant lines shall be selected as Reference Lines.

(c) Pantograph dynamic contact force

The requirements on dynamic contact force are set out in clause 4.2.16 of the High Speed Energy TSI:2006.

4.2.8.3.6.2. Arrangement of pantographs

Trains shall be designed to be able to move from one power supply system or from one phase section to an adjacent one without bridging either system or phase separation sections.

It is permissible for more than one pantograph to be simultaneously in contact with the overhead contact line equipment. Figure 3 illustrates the requirements for arrangement of pantographs.

In accordance with the maximum train length, the maximum spacing between the first and last pantograph (L_1) shall be less than 400 m in order to negotiate the specified types of separation sections. Where more than two pantographs are simultaneously in contact with the overhead contact line, the spacing between any pantograph and the third consecutive one marked as (L_2) shall be more than 143 m. The spacing between any two consecutive pantographs in contact with the overhead contact line shall be greater than 8m for these specified types of separation sections.

If the spacing between any pantographs does not meet the previous requirement then there shall be an operational rule to lower pantographs to permit trains to negotiate separation sections.

The number of pantographs and their spacing shall be selected taking into consideration the requirements of current collection performance (as defined in clause 4.2.16 of the High Speed Energy TSI 2006). The intermediate pantograph may be arranged at any position

When operating on AC power systems, trains with multiple pantographs shall not have electrical links between the pantographs in use.

Where the spacing of consecutive pantographs is less than the spacing shown in table 4.2.19 of the High Speed Energy TSI:2006 rolling stock shall demonstrate by testing that, for the overhead contact line equipment defined in section 4.2 of the High Speed Energy TSI 2006, the current collection quality as defined in clause 4.2.16.1 of the Energy TSI 2006 is met for the poorest performing pantograph.

Figure 3

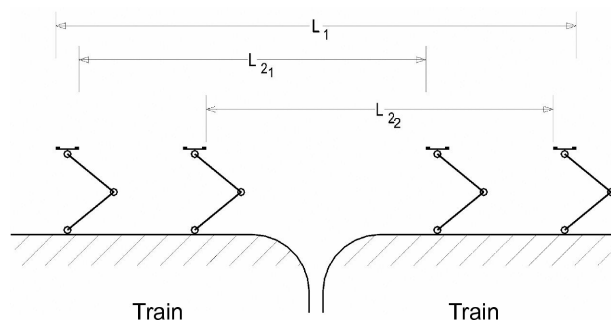
Arrangement of pantographs

4.2.8.3.6.3. Insulation of pantograph from the vehicle

The pantographs shall be assembled on the roof of the vehicles and insulated from earth. The insulation shall be adequate for all system voltages. References for data to be verified are in EN50163:2004, clause 4, for system voltages and EN50124-1:2001, Table A2, for insulation coordination requirements..

4.2.8.3.6.4. Pantograph lowering

Rolling stock shall be equipped with a device that lowers the pantograph in case of a failure meeting the requirements of EN50206-1:1998, clause 4.9.

Rolling stock shall lower the pantograph in a period meeting the requirements of EN50206-1:1998, clause 4.8 and to the dynamic insulating distance according to EN 50119:2001 table 9 either by initiation by the driver or in response to control-command signals. The pantograph shall lower to the housed position in less than 10 seconds.

Conformity assessment shall be made in accordance with the requirements of EN50206-1: 1998, clauses 6.3.2 and 6.3.3.

4.2.8.3.6.5. Quality of current collection

In normal operation the quality of current collection shall meet the requirements of clause 4.2.16 of the High Speed Energy TSI 2006. The conformity assessment shall be made with a reference catenary. Definition of a reference catenary remains an open point in the High Speed Energy TSI.

NQ, the percentage of arcing duration, is defined in clause 4.2.16 of the High Speed Energy TSI 2006

If, in the event of a failure of the normal operating pantograph, continued operation at normal speed using a backup pantograph is required, the value of NQ shall not exceed 0,5. If operation at normal speed is not required, the train shall operate at such a speed that maintains the normal value of NQ.

4.2.8.3.6.6. Electrical protection coordination

Electrical protection coordination design shall comply with the requirements detailed in clause 11 of EN50388:2005.

Conformity assessment shall be carried out according to the requirements of clause 14.6 of EN50388:2005.

4.2.8.3.6.7. Running through phase separation sections

Trains intended to operate on lines that are fitted with control-command and signalling devices that communicate the requirements of separation sections on a line to trains shall be fitted with systems able to receive this information from these devices.

For Class 1 trains operating on such the subsequent actions shall be triggered automatically.

For Class 2 trains operating on such lines, the action is not required to be automatic, but the traction-unit shall monitor for the intervention of the driver, and if necessary act.

As a minimum, these devices shall enable power consumption (both traction and auxiliaries, and for the no load current of the transformer) to be automatically brought to zero and the main circuit breaker opened before the traction unit enters a separation section, without the intervention of the driver. On leaving the separation section, the devices shall cause the main circuit breaker to be closed and power consumption to be resumed.

Additionally, where phase separation sections require pantographs on a train to be lowered and subsequently raised, these additional actions are permitted to be automatically initiated. These functions shall respond to input signals from the control-command and signalling subsystem.

4.2.8.3.6.8. Running through system separation sections

The available options for running through system separation sections are described in clauses 4.2.22.2 and 4.2.22.3 of the High Speed Energy TSI 2006.

Before running through system separation sections the traction unit's main circuit breaker shall be opened.

When pantographs are not lowered from the contact wire, only those electric circuits on the traction units, which instantaneously conform to the power supply system at the pantograph, may remain connected.

After running through a system separation section, a traction unit shall detect the new system voltage at the pantograph. The modification of the configuration of traction equipment shall be made either automatically or manually.

4.2.8.3.6.9. Height of pantographs

The installation of a pantograph on a traction unit shall allow interaction with contact wires at heights between 4 800 mm and 6 500 mm above rail level.

4.2.8.3.7. Interoperability constituent pantograph

4.2.8.3.7.1. Overall design

Pantographs are devices for collecting currents from one or more contact wires, and for transmitting the current to the traction unit on which they are mounted. They are designed to allow vertical movement of the pantograph head. The pantograph head carries the contact strips and their mountings. The ends of the pantograph head are formed by down-turned horns.

The pantograph shall meet the specified performance as far as maximum running speed and current carrying capacity are concerned. Pantograph requirements are specified in clause 4 of EN50206-1:1998.

Requirements on dynamic behaviour and quality of current collection shall be assessed in accordance with the High Speed Energy TSI 2006 clause 4.2.16.2.2.

4.2.8.3.7.2. Pantograph head geometry

Pantograph heads with the same principal dimensions shall be used on all categories of lines for AC and DC systems. The length and the conducting range of the pantograph head and the profile are defined to achieve interoperability. The profile of the pantograph head shall be as depicted in Figure 4.

Figure 4

Profile of pantograph head

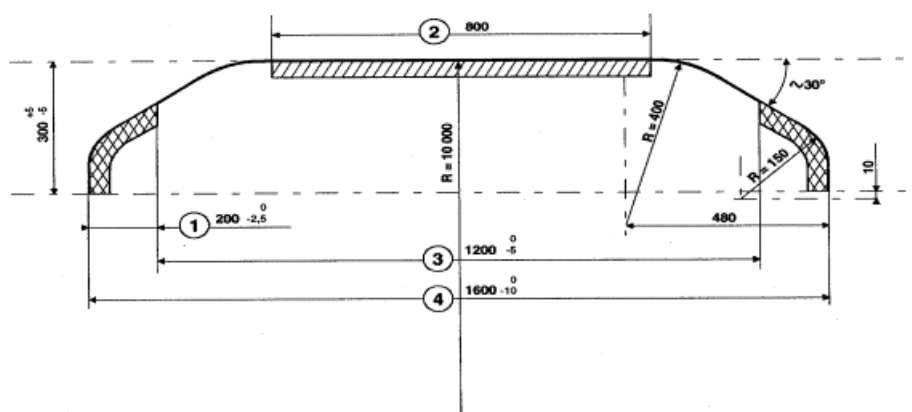

1. Horn made of insulating material (projected length 200mm)
2. Minimum length of the contact strip 800 mm
3. Conducting range of collector head 1 200 mm
4. Pantograph head length 1 600 mm

Pantograph heads fitted with contact strips having independent suspensions shall remain compliant to the overall profile with a static contact force of 70N applied to the middle of the head. The permissible value for pantograph head skew is defined in EN 50367:2006 clause 5.2.

Contact between contact wire and pantograph head is possible outside the contact strips and within the whole conducting range over limited line sections under adverse conditions, e.g. coincidence of vehicle swaying and high winds.

4.2.8.3.7.3. Pantograph static contact force

The static contact force is the vertical contact force exerted upward by the pantograph head on the contact wire and caused by the pantograph-raising device, whilst the pantograph is raised and the vehicle is at standstill.

The static contact force exerted by the pantograph on the contact wire, as defined in EN50206-1:1998 clause 3.3.5, shall be adjustable within the following ranges:

- 40N to 120N for AC supply systems,
- 50 N to 150N for DC supply systems,

The pantographs and their mechanisms that provide the necessary contact forces shall ensure that a pantograph is capable of being used on overhead line equipment compliant to the High Speed Energy TSI 2006. For details and assessment, reference shall be made to EN 50206-1:1998, clause 6.3.1

4.2.8.3.7.4. Working range of pantographs

Pantographs shall have a working range of at least 1 700 mm. Conformity assessment shall be made in accordance with the requirements of clauses 4.2 and 6.2.3 of EN 50206-1: 1998.

4.2.8.3.7.5. Current capacity

Pantographs shall be designed for the rated current to be transmitted to the vehicles. The manufacturer shall state the rated current. An analysis shall demonstrate that the pantograph is able to carry the rated current. Conformity assessment shall be made in accordance with the requirements of clause 6.13 of EN50206-1: 1998.

4.2.8.3.8. Interoperability constituent contact strip

4.2.8.3.8.1. General

Contact strips are the replaceable parts of the pantograph head, which are in direct contact with the contact wire and as a consequence, are prone to wear. Conformity assessment shall be carried out in accordance with the requirements of clauses 5.2.2 to 5.2.4, 5.2.6 and 5.2.7 of EN50405:2006.

4.2.8.3.8.2. Contact strip geometry

The length of the contact strips is defined in Figure 4.

4.2.8.3.8.3. Material

The material used for the contact strips shall be mechanically and electrically compatible with the contact wire material (as specified in 4.2.11 of the High Speed Energy TSI 2006), in order to avoid excessive abrasion of the surface of the contact wires, thereby minimising wear of both contact wires and contact strips. Plain carbon or carbon impregnated with additive material shall be used in interaction with contact wires made from copper or copper alloys. Contact strip material shall comply with clause 6.2 of EN 50367: 2006.

4.2.8.3.8.4. Detection of contact strip breakage

Contact strips shall be designed so that any damage that is sustained which is likely to damage the contact wire initiates the automatic lowering device.

Conformity assessment shall be carried out in accordance with the requirements of EN50405:2006 clause 5.2.5.

4.2.8.3.8.5. Current capacity

The material and cross-section of contact strips shall be selected according to the maximum current requirement. The rated current shall be stated by the manufacturer. Type tests shall demonstrate the conformity as specified in clause 5.2 of EN50405:2006.

Contact strips shall be capable of transmitting the current drawn by traction units at standstill. Conformity assessment shall be carried out in accordance with EN50405:2006 clause 5.2.1.

4.2.8.3.9. Interfaces with electrification system

For electrically powered trains, the principal interface elements between the rolling stock and the energy subsystems are defined in the High-Speed Energy and Rolling Stock TSIs.

They are as follows:

- The maximum power that can be drawn from the overhead contact line [see clause 4.2.8.3.2 of this TSI and clause 4.2.3 of the High Speed Energy TSI 2006]
- The maximum current that can be drawn at standstill [see clause 4.2.8.3.2 of this TSI and clause 4.2.20 of the High Speed Energy TSI 2006]
- The voltage and the frequency of the power supply [see clause 4.2.8.3.1.1 of this TSI and clause 4.2.2 of the High Speed Energy TSI 2006]
- Over-voltages generated on the overhead line by harmonics [see clause 4.2.8.3.4 of this TSI and clause 4.2.25 of the High Speed Energy TSI 2006]
- Electrical protection measures [see clause 4.2.8.3.6.6 of this TSI and clause 4.2.23 of the High Speed Energy TSI 2006]
- The arrangement of the pantographs [see clause 4.2.8.3.6.2 of this TSI and clauses 4.2.19, 4.2.21 and 4.2.22 of the High Speed Energy TSI 2006]
- Running through phase separation sections [see clause 4.2.8.3.6.7 of this TSI and clause 4.2.21 of the High Speed Energy TSI 2006]
- Running through system separation sections [see clause 4.2.8.3.6.8 of this TSI and clause 4.2.22 of the High Speed Energy TSI 2006]
- Pantograph contact force [see clause 4.2.8.3.6.1 of this TSI and clause 4.2.14, and 4.2.15 of the High Speed Energy TSI 2006]
- Power factor [see clause 4.2.8.3.3 of this TSI and clause 4.2.3 of the High Speed Energy TSI 2006]
- Regenerative braking [see clause 4.2.8.3.1.2] defined in clause 4.2.4 of the High Speed Energy TSI 2006.
- Pantograph head geometry [see clause 4.2.8.3.7.2 of this TSI and clause 4.2.13 of the High Speed Energy TSI 2006]
- Dynamic behaviour of pantographs and quality of current collection [see clause 4.2.8.3.6.5 of this TSI and clause 4.2.16 of the High Speed Energy TSI 2006]

4.2.8.3.10. Interfaces with control-command and signalling subsystem

The minimum impedance between pantograph and wheels of the rolling stock is specified in clause 3.6.1 of Annex A Appendix 1 of the Control-Command and Signalling TSI 2006.

4.2.9. Servicing

4.2.9.1. General

Servicing and minor repairs necessary to ensure a safe return journey shall be able to be carried out on parts of the network distant from the vehicles' home base, including whilst stabled on a foreign network.

Trains shall be capable of being stabled, with no crew onboard, with power supply from the catenary or auxiliary power supply maintained for lighting, air conditioning, refrigerated cabinets, etc.

4.2.9.2. Train external cleaning facilities

It shall be possible for the front windows of drivers' cabs to be cleaned both from the ground and from platform heights of 550mm and 760mm using suitable (with particular regard to health and safety aspects) cleaning equipment, in all stations and facilities at which the trains call or are stabled.

It shall be possible for the speed at which the train passes through the train washing plant to be adapted to suit each washing plant, i.e. between 2 and 6 km/h.

4.2.9.3. Toilet discharge system

4.2.9.3.1. On board discharge system

The design of the toilet discharge system shall allow sealed toilets (using clear or recycled water) to be emptied at sufficient intervals, so that the emptying operations can be performed on a scheduled basis at designated depots.

The following connections on the rolling stock are interoperability constituents.

- The 3" Evacuation nozzle (Inner part) is defined in Annex M VI Figure M VI.1.
- The flushing connection for the toilet tank (Inner part), the use of which is optional, is defined in Annex M VI Figure M VI.2.

4.2.9.3.2. Mobile discharge trolleys

Mobile discharge trolleys are interoperability constituents.

Mobile toilet discharge installations shall be compatible with the characteristics of at least one on board discharge system (using clean or recycled water).

Mobile discharge trolleys shall perform all of the following functions:

- Discharge,
- Suction (the limit value for the suction vacuum is set at 0,2 bar),
- Rinsing (only applies to retention toilet discharge equipment),
- Pre-loading or filling with additive (only applies to retention toilet discharge equipment),

The connections on the discharge trolleys (3" for emptying and 1" for rinsing) and their seals shall comply with figures M IV.1 and M IV.2 respectively of Annex M IV.

4.2.9.4. Train interior cleaning

4.2.9.4.1. General

A 3 000 VA at 230V, 50Hz electrical power supply connection shall be provided in each coach for powering industrial cleaning equipment. This power shall be available simultaneously in all the coaches of a trainset. Electric power sockets inside the train shall be spaced such that no part of the coach that needs to be cleaned is more than 12 metres from one of the sockets.

4.2.9.4.2. Electrical sockets

The interior electrical sockets shall be compatible with plugs that are compliant to CEE 7 Standard Sheet VII (16 A-250 V, compare Figure 5).

Figure 5

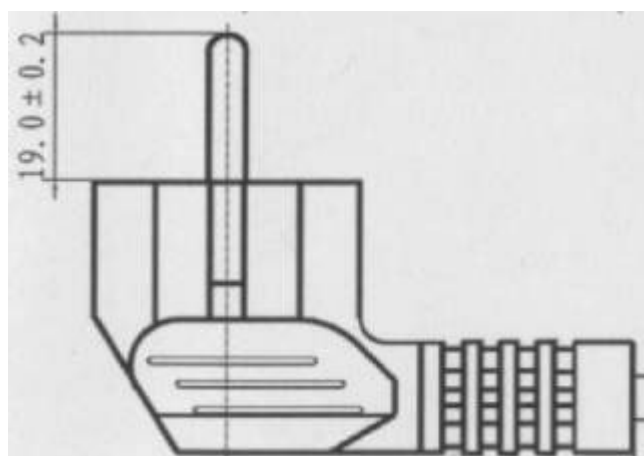
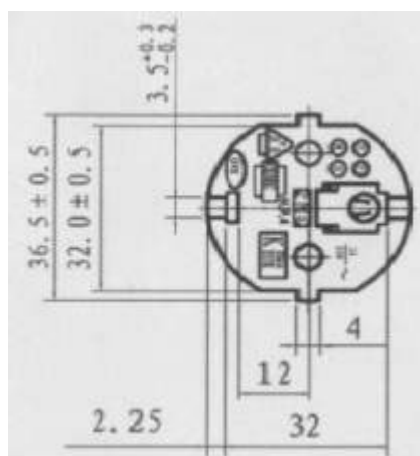
Plug according to CEE 7 Standard Sheet VII (not all dimensions shown)

Dimensions and tolerances are given for information only. The dimensions and tolerances shall be according to the referred standard.

4.2.9.5. Water restocking equipment

4.2.9.5.1. General

New equipment for water supply on the interoperable network shall be supplied with drinking water in accordance with Directive 98/83/EC, and its mode of operation shall ensure that water delivered at the last element of the fixed part of these installations complies with the quality specified by this same Directive for water intended for human consumption.

4.2.9.5.2. Water filling adapter

The water filling adapters are interoperability constituents, which are defined in Annex M V.

4.2.9.6. Sand restocking equipment

Sandboxes are normally filled during scheduled maintenance operations in specialised workshops in charge of trainset maintenance. However, if required, sand meeting local specifications for this use shall be made available to fill sand boxes so that rolling stock can continue in commercial service until it returns to its maintenance centre.

4.2.9.7. Special requirements for stabling of trains

Rolling stock shall be designed so that:

- Periodic monitoring is not necessary when stabled and connected electrically to an electrical supply system,
- It can be configured for different functional levels (e.g. standby, preparation, etc.),
- An absence of voltage does not damage any rolling stock constituent,

4.2.9.8. Refuelling equipment

Open point

4.2.10. Maintenance

4.2.10.1. Responsibilities

All maintenance activities undertaken on rolling stock shall be performed in accordance with the provisions of this TSI.

All maintenance shall be undertaken in accordance with the maintenance file applicable to the rolling stock.

The maintenance file shall be managed in accordance with the provisions specified in this TSI.

After delivery of the rolling stock by the supplier, and acceptance thereof, a single entity shall assume responsibility for the management of changes affecting the design integrity, for the maintenance of the rolling stock and for the management of the maintenance file.

The rolling stock register shall state the entity responsible for the maintenance of the rolling stock and the management of the maintenance file.

4.2.10.2. The maintenance file

The maintenance file shall be composed of

- the maintenance design justification file and
- the maintenance documentation.

4.2.10.2.1. The maintenance design justification file

The maintenance design justification file

- describes the methods used to design the maintenance
- describes the tests, investigations, calculations carried out to design the maintenance
- gives the relevant data used for this purpose and justifies its origin
- describes the resources needed for the maintenance of rolling stock.

This file shall contain:

- Name and department of the manufacturer and/or the railway undertaking responsible for the maintenance file.
- Precedents, principles and methods used to design the maintenance of the vehicle.

- Utilisation profile (Limits of the normal utilisation of the vehicle (e.g. km/month, climatic limits, authorised types of loads etc.) taken into account for the design of the maintenance).
- Tests, investigations, calculations carried out.
- Relevant data used to design the maintenance and origin of these data (return of experience, tests ...).
- Responsibility and traceability of the design process (name, skills and position of the author and approver of each document).
- Resources needed for the maintenance (e.g. required time for inspections, replacement of parts, life time of components etc.)

4.2.10.2.2. The Maintenance Documentation

The maintenance documentation consists of all the documents necessary to carry out the management and execution of the maintenance of the vehicle. It shall be composed of the following:

- Component hierarchy and functional description: The hierarchy sets up the boundaries of the rolling stock by listing all the items belonging to the product structure of that rolling stock and using an appropriate number of discrete levels. The last item shall be a replaceable unit.
- Schematic circuit diagrams, connection diagrams and wiring diagrams
- Parts List: Containing the technical descriptions of the spare parts (replaceable units) in order to allow identification and procurement of the correct spares.
- Safety/interoperability-relevant limits: For the safety/interoperability relevant components or parts according to this TSI, this document shall give the measurable limits not to be exceeded in service (to include operation in degraded mode). Safety critical data (see Directive 96/48/EC as modified by Directive 2004/50/EC Article 14(5)e) relating to the maintenance schedule of the vehicle shall be included in the rolling stock register.
- European legal obligations: Where components or systems are subject to specific European legal obligations these obligations shall be listed.
- Maintenance plan
 - List, schedule and criteria of all planned preventative maintenance operations,
 - List and criteria of conditional preventative maintenance operations,
 - List of relevant corrective maintenance operations,
 - Maintenance operations depending on specific conditions of use.

The level of the maintenance operations shall be described.

Note: Some maintenance operations like overhauls and very heavy repairs may not be able to be defined at the moment when the vehicle is put into service. In this case, the responsibility and the procedures to define such maintenance operations shall be described.

- Maintenance manuals and leaflets

For each maintenance operation listed in the maintenance plan, the manual explains the list of the tasks to be carried out.

Where maintenance tasks are common to different operations or common to different vehicles it is permissible to explain them in specific maintenance leaflets.

The manuals and leaflets shall contain the following information:

- Specific tools and facilities including service software
- Standardised or statutory specific staff competencies required (welding, non destructive testing ...)
- General requirements relative to mechanical, electrical, fabrication and other engineering competencies.
- Occupational and operational health and safety provisions (including applicable legislation appertaining to the controlled use of substances hazardous to health and safety).
- Environmental provisions
- Details of the task to be carried out as a minimum:
 - Disassembly/assembly instructions
 - Maintenance criteria
 - Checks and tests
 - Tools and materials required to undertake the task
 - Consumables required to undertake the task
 - Personal protective safety equipment
- Necessary tests and procedures to be undertaken after each maintenance operation before putting into service.
- Traceability and records.
- Troubleshooting (fault diagnosis) manual including functional and schematic diagrams of the systems

4.2.10.3. Management of the maintenance file.

The maintenance file shall be supplied with the first train or vehicle of a series, either by the manufacturer or/and the railway undertaking and submitted to the processes as specified in clause 6.2.4 of this TSI, before putting into service. This section does not apply to prototypes when they are being used for evaluation purposes.

After putting the first train or vehicle of a series into service the railway undertaking is responsible for the management of the maintenance file appertaining to rolling stock for which it has management responsibility relative to the provisions specified within this TSI. This includes a process of regular review of the maintenance file to ensure compliance with the essential requirements.

The maintenance file shall be managed in accordance with the processes defined in the certified safety management system of the railway undertaking.

In the case where railway undertakings carry out maintenance on the rolling stock they use, the railway undertaking shall ensure processes are in place to manage the maintenance and operational integrity of the rolling stock, including:

- Information in the rolling stock register,
- Asset Management, including records of all maintenance undertaken and due on the rolling stock (which shall be subject to specified retention periods for differing levels of archive storage).

- Software where relevant.
- Procedures for the receipt and processing of specific information related to the operational integrity of rolling stock, arising as a result from any circumstance including but not limited to operational or maintenance incidents, that have a potential to affect the safety integrity of rolling stock.
- Procedures for the identification, generation and dissemination of specific information related to the operational integrity of rolling stock, arising as a result from any circumstance including but not limited to operational or maintenance incidents, with a potential to affect the safety integrity of rolling stock, and which is identified during any maintenance activity.
- Operational duty profiles of rolling stock. (Including but not limited to total kilometres travelled).
- Processes for the protection and validation of such systems.

In accordance with the provisions of Directive 2004/49 Annex III, the safety management system of the railway undertaking shall demonstrate that suitable maintenance arrangements are in place, thereby ensuring on-going compliance with the essential requirements and the requirements of this TSI including the requirements of the maintenance file.

In the case of entities other than the railway undertaking using rolling stock, being responsible for the maintenance of this rolling stock, the railway undertaking using the rolling stock shall ascertain that all relevant maintenance processes are in place and are actually applied. This process shall also be suitably described within the safety management system of the railway undertaking.

The entity responsible for the maintenance of the rolling stock shall ensure that reliable information about maintenance processes and data specified to be made available in the TSIs are available for the operating railway undertaking, and shall demonstrate on request of the operating railway undertaking that these processes ensure the compliance of the rolling stock with the Essential Requirements of Directive 96/48/EC as modified by Directive 2004/50/EC.

4.2.10.4. Management of maintenance information.

The entity responsible for the maintenance of rolling stock shall ensure that it has processes for the management of, and secured access rights to, information relative to the management, maintenance and operational integrity of rolling stock. Other parties operationally involved in this process shall provide the required maintenance information. This information shall include:

- rolling stock register.
- Configuration management information
- Maintenance management information systems including records of all maintenance undertaken and maintenance, due on rolling stock, for which it is responsible (which shall be subject to specified time periods for differing levels of archive storage).
- Management procedures for the receipt and processing of specific information relative to the operational integrity of rolling stock including operational and/or maintenance incidents with a potential to affect the safety integrity of rolling stock.
- Management procedures for the identification, generation and dissemination of specific information relative to the operational integrity of rolling stock, including operational and/or maintenance incidents, with a potential to affect the safety integrity of rolling stock, and which is identified during any maintenance activity including repair of parts.
- Operational duty profiles of rolling stock (e.g. kilometres).
- Security management processes for protection and validation of the information systems.

4.2.10.5. Implementation of the maintenance

The railway undertaking shall schedule rosters so that each train returns at staggered intervals to designated bases where the major maintenance operations will be carried out at frequencies compatible with the design and reliability of high-speed trains.

When a train is in a degraded state, the conditions under which some repair work can be undertaken to allow its safe return to a designated base and the special operating conditions shall be agreed, case by case, between the infrastructure managers and the railway undertaking or by a document as required by clause 4.2.1

4.3. **Functional and technical specification of the interfaces**

4.3.1. General

As far as technical compatibility is concerned, these are the interfaces of the rolling stock subsystem with the other subsystems:

- The design of the trains
- Driver vigilance device
- The electrification system
- On-board train control equipment
- Platform height
- The door controls
- Emergency exits
- Headlights
- Emergency couplers
- Wheel/rail contact
- Axle bearing health monitoring
- Passenger alarm
- Pressure wave effects
- Effect of cross-winds
- Brakes independent of wheel/rail adhesion
- Flange lubrication
- Coefficient of flexibility

The interfaces are defined in the following sections in order to assure the coherence of a consistent High Speed Trans-European network.

In the light of the essential requirements in Section 3, the functional and technical specifications of the interfaces are arranged by subsystem in the following order:

- Infrastructure subsystem
- Energy subsystem.

- Control-command and signalling subsystem
- Operation subsystem

For each of these interfaces, the specifications are arranged in the same order as in section 4.2, as follows:

- Structures and mechanical parts
- Track interaction and gauging
- Braking
- Passenger information and communication
- Environmental conditions
- System protection
- Traction and electrical equipment
- Servicing
- Maintenance

The following list is endorsed to indicate which subsystems are identified as having interface with basic parameters of this TSI:

— **Structures and mechanical parts (clause 4.2.2):**

Design of trains (clause 4.2.1.2): Operation subsystem

End couplers and coupling arrangements to rescue trains (clause 4.2.2.2): Operation subsystem

Strength of vehicle structure (clause 4.2.2.3): No interfaces identified.

Access (clause 4.2.2.4): Infrastructure subsystem and operation subsystem

Toilets (clause 4.2.2.5): Operation subsystem

Driver's cab (clause 4.2.2.6): Infrastructure subsystem and control-command and signalling subsystem.

Windscreen and front of the train (clause 4.2.2.7): Control-command and signalling subsystem.

— **Vehicle track interaction and gauging (clause 4.2.3):**

Kinematic gauge (clause 4.2.3.1): Infrastructure subsystem

Static axle load (clause 4.2.3.2): Infrastructure subsystem and control-command and signalling subsystem

Rolling stock parameters, which influence ground based train monitoring systems (clause 4.2.3.3): Infrastructure subsystem and control-command and signalling subsystem and operation subsystem

Rolling stock dynamic behaviour (clause 4.2.3.4): Infrastructure subsystem and operation subsystem

Maximum train length (clause 4.2.3.5): Infrastructure subsystem and operation subsystem

Maximum Gradients (clause 4.2.3.6): Infrastructure subsystem

Minimum curve radius (clause 4.2.3.7): Infrastructure subsystem

Flange lubrication (clause 4.2.3.8): Infrastructure subsystem

Suspension coefficient (clause 4.2.3.9): Energy subsystem

Sanding (clause 4.2.3.10): Control-command and signalling subsystem and operation subsystem

Aerodynamic effects on ballast (clause 4.2.3.11): Infrastructure subsystem and operation subsystem

— **Braking (clause 4.2.4):**

Braking performance (clause 4.2.4.1): Control-command and signalling subsystem and operation subsystem

Brake wheel/rail adhesion demand limits (clause 4.2.4.2): No interfaces identified

Brake system requirements (clause 4.2.4.3): Energy subsystem and operation subsystem

Service Braking Performance (clause 4.2.4.4): No interfaces identified

Eddy current brakes (clause 4.2.4.5): Infrastructure subsystem and operation subsystem

Protection of an immobilised train (clause 4.2.4.6): Operation subsystem

Brake performance on steep gradients (clause 4.2.4.7): Infrastructure subsystem and operation subsystem

— **Passenger information and communication (clause 4.2.5):**

Public address system (clause 4.2.5.1): Operation subsystem

Passenger information signs (clause 4.2.5.2): No interfaces identified

Passenger alarm (clause 4.2.5.3): Infrastructure subsystem and operation subsystem

— **Environmental conditions (clause 4.2.6)**

Environmental conditions (clause 4.2.6.1): Infrastructure subsystem and operation subsystem

Train aerodynamic loads in open air (clause 4.2.6.2): Infrastructure subsystem and operation subsystem

Crosswind (clause 4.2.6.3): Infrastructure subsystem and operation subsystem

Maximum Pressure Variations in Tunnels (clause 4.2.6.4): Infrastructure subsystem and operation subsystem

Exterior Noise (clause 4.2.6.5): Infrastructure subsystem and operation subsystem

Exterior Electromagnetic Interference (clause 4.2.6.6): Energy subsystem and control-command and signalling subsystem

— **System protection (clause 4.2.7):**

Emergency Exits (clause 4.2.7.1): Operation subsystem

Fire safety (clause 4.2.7.2): Infrastructure subsystem and operation subsystem

Protection against electric shock (clause 4.2.7.3): No interfaces identified

External lights (clause 4.2.7.4): Infrastructure subsystem and energy subsystem and control-command and signalling subsystem and operation subsystem

Horn (clause 4.2.7.4): Operation subsystem

Lifting/rescue procedures (clause 4.2.7.5): Operation subsystem

Interior Noise (clause 4.2.7.6): Operation subsystem

Air Conditioning (clause 4.2.7.7): Infrastructure subsystem and operation subsystem

Driver's Vigilance Device (clause 4.2.7.8): Operation subsystem

Control-command and Signalling system (clause 4.2.7.9): Control-command and signalling subsystem

Monitoring and Diagnostic Concepts (clause 4.2.7.10): Control-command and signalling subsystem and operation subsystem

Particular specification for tunnels (clause 4.2.7.11): Infrastructure subsystem and control-command and signalling subsystem and operation subsystem

Emergency lighting system (clause 4.2.7.12): No interfaces identified

Software (clause 4.2.7.13): No interfaces identified

— **Traction and electrical equipment (clause 4.2.8):**

Traction performance requirements (clause 4.2.8.1): Operation subsystem

Traction wheel/rail adhesion requirements (clause 4.2.8.2): Operation subsystem

Functional and technical specification related to power supply (clause 4.2.8.3): Energy subsystem and control-command and signalling subsystem and operation subsystem

— Servicing (clause 4.2.9): Infrastructure subsystem and operation subsystem

— Maintenance (clause 4.2.10): Infrastructure subsystem and operation subsystem

4.3.2. Infrastructure subsystem

4.3.2.1. Access

Clause 4.2.2.4.1 of this TSI specifies the position of the steps for access. This position depends on the position of the edge of the platform, which is specified in clauses 4.2.20.4 and 4.2.20.5 of the Infrastructure TSI 2006.

4.3.2.2. Driver's cab

Clause 4.2.2.6 of this TSI specifies that the cab shall be accessible from both sides of the train from the ground or from the platform. The height of the platform measured from the level of the rail is specified in clause 4.2.20.4 of the Infrastructure TSI 2006.

- 4.3.2.3. Kinematic gauge
- Clause 4.2.3.1 of this TSI specifies that the rolling stock shall comply with one of the kinematic vehicle gauges that are specified in Annex C of the Conventional Rail Rolling Stock TSI 2005. The corresponding infrastructure gauges are specified in clause 4.2.3 of the Infrastructure TSI 2006, and the infrastructure register states for each line the kinematic gauge that shall be met by the rolling stock operating on this line.
- 4.3.2.4. Static axle load
- Clause 4.2.3.2 of this TSI specifies the maximum static axle loads that are allowed for different types of rolling stock. The corresponding specifications are set out in clause 4.2.13 of the Infrastructure TSI 2006.
- 4.3.2.5. Rolling stock parameters, which influence ground based train monitoring systems
- Clause 4.2.3.3.2 of this TSI details the specifications concerning the rolling stock related to axle bearing health monitoring by trackside hot axle boxes detectors. The minimum infrastructure gauge requirements concerning the infrastructure subsystem are set out in clause 4.2.3 of the Infrastructure TSI 2006.
- 4.3.2.6. Rolling stock dynamic behaviour and wheel profiles
- Clause 4.2.3.4 of this TSI detail the specifications concerning the rolling stock related to rolling stock dynamic behaviour, and particularly the parameters of the wheel profile. The corresponding specifications concerning the infrastructure subsystem, and particularly the parameters of the rail profile, are set out in clauses 4.2.9, 4.2.10, 4.2.11, 4.2.12 and 5.3.1.1 of the Infrastructure TSI 2006.
- 4.3.2.7. Maximum train length
- Clause 4.2.3.5 of this TSI specifies the maximum length of the train. The maximum length of the platform is specified in clause 4.2.20.2 of the Infrastructure TSI 2006, and the infrastructure register states for each line the minimum length of platform where high speed trains are intended to call at.
- 4.3.2.8. Maximum gradients
- Clause 4.2.3.6 of this TSI specifies that trains shall be able to start, operate and stop on all the lines for which it is designed to operate. The maximum gradient is specified in clause 4.2.5 of the Infrastructure TSI 2006, and the infrastructure register states for each line the maximum gradient.
- 4.3.2.9. Minimum curve radius
- Clause 4.2.3.7 of this TSI specifies that trains shall be able to negotiate the minimum curve radius on all the lines for which it is designed to operate. The minimum curve radius is specified in clauses 4.2.6, 4.2.8 and 4.2.25 of the Infrastructure TSI 2006, and the infrastructure register states for each line the minimum curve radius on high speed tracks and on stabling tracks.
- 4.3.2.10. Flange lubrication
- There is no interface related to flange lubrication with the Infrastructure TSI.
- 4.3.2.11. Ballast pick up
- Clause 4.2.3.11 of this TSI details the specifications concerning the rolling stock related to aerodynamic effects on ballast. The corresponding specifications concerning the infrastructure subsystem are set out in clause 4.2.27 of the Infrastructure TSI 2006.
- 4.3.2.12. Eddy current brake
- Clause 4.2.4.5 of this TSI details the specifications concerning the rolling stock related to the use of eddy current brake. The corresponding specifications concerning the infrastructure subsystem are set out in clause 4.2.13 of the Infrastructure TSI 2006, and the infrastructure register states for each line the conditions for use of eddy current brake.

- 4.3.2.13. Brake performance on steep gradients
- Clause 4.2.4.7 of this TSI details the specifications concerning the rolling stock related to the brake performance on steep gradients. The corresponding specifications concerning the infrastructure subsystem are set out in clause 4.2.5 of the Infrastructure TSI 2006, and the infrastructure register states for each line the maximum gradient.
- 4.3.2.14. Passenger alarm
- There is no interface related to passenger alarm with the Infrastructure TSI.
- 4.3.2.15. Environmental conditions
- There is no interface related to environmental conditions with the Infrastructure TSI.
- 4.3.2.16. Train aerodynamic loads in open air
- Clause 4.2.6.2 of this TSI details the specifications concerning the rolling stock related to the train aerodynamic loads in open air. The corresponding specifications concerning the infrastructure subsystem are set out in clauses 4.2.4, 4.2.14.7 and 4.4.3 of the Infrastructure TSI 2006.
- 4.3.2.17. Crosswind
- Clause 4.2.6.3 of this TSI details the specifications concerning the rolling stock related to the crosswind. The corresponding specifications concerning the infrastructure subsystem are set out in clause 4.2.17 of the Infrastructure TSI 2006.
- 4.3.2.18. Maximum pressure variations in tunnels
- Clause 4.2.6.4 of this TSI details the specifications concerning the rolling stock related to the maximum pressure variations in tunnels. The corresponding specifications concerning the infrastructure subsystem are set out in clause 4.2.16 of the Infrastructure TSI 2006.
- 4.3.2.19. Exterior noise
- Clause 4.2.6.5 of this TSI details particular specification related to the exterior noise emitted by the rolling stock. The corresponding specifications concerning the infrastructure subsystem are set out in clause 4.2.19 of the Infrastructure TSI 2006.
- 4.3.2.20. Fire safety
- Clause 4.2.7.2 of this TSI details particular specifications related to fire safety for trains operating in tunnels and/or on elevated sections with a length exceeding 5km. The specifications concerning the infrastructure subsystem, related to tunnels and/or elevated sections are specified in clause 4.2.21 of the Infrastructure TSI 2006, and the infrastructure register states for each line where tunnels and/or on elevated sections with a length exceeding 5km are located or how they are identified.
- 4.3.2.21. Head lights
- There is an interface between the head lights (clause 4.2.7.4.1.1 of this TSI) in term of illuminance and the characteristics of reflective clothes of staff working on or near the track described in clause 4.7 of the Infrastructure TSI 2006.
- 4.3.2.22. Particular specification for tunnels
- Clause 4.2.7.11 of this TSI details the specifications concerning the rolling stock related to operation in tunnels. The corresponding specifications concerning the infrastructure subsystem are specified in clause 4.2.21 of the Infrastructure TSI 2006, and the infrastructure register states for each line where tunnels are located or how they are identified.

4.3.2.23. Servicing

Clause 4.2.9 of this TSI details the specifications concerning the rolling stock related to servicing. The corresponding specifications concerning the infrastructure subsystem are specified in clause 4.2.26 of the Infrastructure TSI 2006.

4.3.2.24. Maintenance

There is no interface related to maintenance with the Infrastructure TSI.

4.3.3. Energy subsystem

4.3.3.1. Reserved

4.3.3.2. Brake system requirements

Clauses 4.2.4.3 and 4.2.8.3.1.2 of this TSI detail the specifications concerning the rolling stock related to regenerative braking requirements. The corresponding specifications concerning the energy subsystem are specified in clause 4.2.4 of the High-Speed Energy TSI 2006, and the infrastructure register states for each line where these specifications apply.

4.3.3.3. Exterior electromagnetic interference

Clause 4.2.6.6 of this TSI details the specifications concerning the rolling stock related to exterior electromagnetic interference. The corresponding specifications concerning the energy subsystem are specified in clause 4.2.6 of the Energy TSI 2006.

4.3.3.4. Head lights

There is an interface between the head lights (clause 4.2.7.4.1.1 of this TSI) in term of illuminance and the characteristics of reflective clothes of staff working on or near the track described in clause 4.7 of the Energy TSI 2006.

4.3.3.5. Functional and technical specification related to power supply

Clause 4.2.8.3 of this TSI details the specifications concerning the rolling stock related to power supply. The corresponding specifications concerning the energy subsystem are specified in clauses 4.2.2, 4.2.3, 4.2.4, 4.2.9.1, 4.2.9.2, 4.2.10, 4.2.11, 4.2.14, 4.2.15, 4.2.16, 4.2.17, 4.2.18, 4.2.19, 4.2.20, 4.2.21, 4.2.22, 4.2.23, 4.2.24 and 4.2.25 of the Energy TSI 2006. The specifications concerning the energy subsystem, related to the position of the catenary, are specified in clause 4.2.9 of the Energy TSI 2006.

4.3.4. Control-Command and Signalling Subsystem

4.3.4.1. Driver's cab

Clause 4.2.2.6 of this TSI details the specifications concerning the rolling stock related to external visibility of the signals by the driver. The position of the signals is specified in clause 4.2.16 of the Control-Command and Signalling TSI 2006.

4.3.4.2. Windscreen and front of the train

Clause 4.2.2.7 of this TSI specifies that the windscreen shall not alter the colour of the signals. The colour of the signals is specified in clause 4.2.16 of the Control-Command and Signalling TSI 2006.

4.3.4.3. Static axle load

Clause 4.2.3.2 of this TSI specifies the minimum static axle loads. The corresponding specifications concerning the control-command and signalling subsystem are set out in the Control-Command and Signalling TSI 2006 clause 4.2.11 and Annex A Appendix 1 Clause 3.1.

4.3.4.4. Rolling stock parameters, which influence ground based train monitoring systems

Clause 4.2.3.2.3 of this TSI details the specifications concerning the rolling stock related to parameters, which influence ground based train monitoring systems, and particularly electrical resistance of the wheelsets and axle bearing health monitoring. The corresponding specifications concerning the control-command and signalling subsystem are set out in clauses 4.2.10 and 4.2.11 of the Control-Command and Signalling TSI 2006 and in its Annex A Appendix 1 clauses 1 to 4

4.3.4.5. Sanding

Clause 4.2.3.10 of this TSI details the specifications concerning the rolling stock related to limitation of use of sanding related to the interface with the control-command and signalling subsystem. The corresponding specifications concerning the control-command and signalling subsystem are set out in clause 4.2.11 of the Control-Command and Signalling TSI 2006 and in its Annex A Appendix 1 clause 4.1.

4.3.4.6. Braking performance

Clause 4.2.4.1 of this TSI specifies that an infrastructure manager is permitted to define further requirements because of different Class B control-command and signalling systems on their part of the network. The corresponding specifications concerning the control-command and signalling subsystem are set out in clause 4.2.2 of the Control-Command and Signalling TSI 2006, and the infrastructure register states these specifications.

Clause 4.2.4.7 of this TSI specifies the braking capability on steep gradients Clause 6.2.1.2 and Annex C of the Control-Command and Signalling TSI 2006 defines how information concerning limiting gradients is transmitted to the train.

4.3.4.7. Electromagnetic interference

Clause 4.2.6.6 of this TSI details the specifications concerning the rolling stock related to electromagnetic interference. The corresponding specifications concerning the control-command and signalling subsystem are set out in clause 4.2.12.2; Annex A index A6 of the Control-Command and Signalling TSI 2006.

4.3.4.8. Control-command and signalling system

Clause 4.2.7.9 of this TSI details specifications concerning the rolling stock related to control-command and signalling system, and particularly wheelset location and wheels. The corresponding specifications concerning wheelset location and wheels are set out in clauses 4.2.11 of the Control-Command and Signalling TSI 2006 and in its Annex A Appendix 1. Position of control-command and signalling system on-board antennae is specified in clauses 4.2.2 and 4.2.5 of the Control-Command and Signalling TSI 2006.

Clause 4.2.7.9.1 of this TSI specifies that operation in particular degraded mode of the control-command and signalling subsystem is specified in clause 4.2.2 of the Control-Command and Signalling TSI 2006. Clause 4.2.7.14 of this TSI specifies the European Traffic Control System display for driving cabs. The requirements specific to the control-command and signalling subsystem are to be found in clause 4.2.2 of the Control-Command and Signalling TSI 2006.

4.3.4.9. Monitoring and diagnostic concepts

Clause 4.2.7.10 of this TSI details the specifications concerning the rolling stock related to monitoring and diagnostic concepts. The corresponding specifications concerning the control-command and signalling subsystem are set out in clause 4.2.2 of the Control-Command and Signalling TSI 2006.

4.3.4.10. Particular specification for tunnels

Clause 4.2.7.11 of this TSI specifies that air inlet or outlet flap on air conditioning systems are permitted to be closed when running in tunnels. The corresponding specifications concerning the control-command and signalling subsystem related to transmission from the ground of the signal to close or open these flaps are set out in clauses 4.2.2 and 4.2.3 and Annex A index 7 and 33 of the Control-Command and Signalling TSI 2006.

4.3.4.11. Functional and technical specification related to power supply

Clauses 4.2.8.3.6.9 and 4.2.8.3.6.10 of this TSI specifies that on board equipment to the requirements transmitted by the control-command and signalling subsystem devices when crossing phase and system separations of the energy subsystem. The corresponding specifications concerning the control-command and signalling subsystem are set out in clauses 4.2.2 and 4.2.3 and Annex A index 7 and 33 of the Control-Command and Signalling TSI 2006.

4.3.4.12. Vehicle front lights

There is an interface between the headlights (clause 4.2.7.4.1.1 of this TSI) in term of illuminance and the characteristics of reflective clothes of staff working on or near the track described in clause 4.7 of the Control-Command and Signalling TSI 2006.

Clause 4.2.16 of the Control-Command and Signalling TSI 2006 specifies that the retro reflecting signs shall meet the requirements for operation in accordance with the clause 4.2.7.4.1.1 of the High Speed Rolling Stock TSI.

4.3.5. Operation subsystem

4.3.5.1. Design of the trains

Clause 4.2.1.2 of this TSI details the specifications concerning the rolling stock related to the design of the trains. Clause 4.2.2.5 and annexes H, J and L of the Operation TSI 2006 specify the rules for the composition of the trains.

4.3.5.2. End couplers and coupling arrangements to rescue trains

Clause 4.2.2.2 of this TSI and its Annex K details the specifications concerning the rolling stock related to end couplers and coupling arrangements to rescue trains, and particularly requirements concerning operation in part 2 of Annex K. The corresponding specifications are set out in clauses 4.2.2.5, 4.2.3.6.3 and 4.2.3.7 of the Operation TSI 2006.

4.3.5.3. Access

Clause 4.2.2.4 of this TSI details the specifications concerning the rolling stock related to passenger steps and access doors. The corresponding specifications are set out in clause 4.2.2.4 of the Operation TSI 2006.

4.3.5.4. Toilets

Clause 4.2.2.5 of this TSI specifies the requirements for the toilet flushing system. There is no specification concerning the rules for elaboration of the roster and servicing of the toilets in the Operation TSI 2006.

- 4.3.5.5. Windscreen and front of the train
- Clause 4.2.2.7 of this TSI details the specifications concerning the rolling stock related to the windscreen. The corresponding specifications concerning the rules for visibility are set out in clause 4.3.2.4 of the Operation TSI 2006.
- 4.3.5.6. Rolling stock parameters, which influence ground based train monitoring systems
- Clause 4.2.3.3.2 of this TSI details the specifications concerning the rolling stock related to axle bearing health monitoring. The corresponding specifications concerning the rules for operation in case of detection of a failure are set out in clause 4.2.3.6 of the Operation TSI 2006.
- 4.3.5.7. Rolling stock dynamic behaviour
- Clause 4.2.3.4 of this TSI details the specifications concerning the rolling stock related to rolling stock dynamic behaviour. The corresponding specifications concerning the rules for operation in case of detection of instability are set out in clause 4.2.3.6 of the Operation TSI 2006.
- 4.3.5.8. Maximum train length
- Clause 4.2.3.5 of this TSI details the specifications concerning the rolling stock related to maximum train length. The corresponding specifications concerning the rules for operation where the length of the train and the length of the platform do not match are set out in clauses 4.2.2.5, 4.2.3.6.3 and 4.2.3.7 of the Operation TSI 2006.
- 4.3.5.9. Sanding
- Clause 4.2.3.10 of this TSI details the specifications concerning the rolling stock related to sanding. The corresponding specifications concerning the rules for manual sanding or inhibition of automatic sanding by the driver are set out in clause C.1 of annex B and annex H to the Operation TSI 2006.
- 4.3.5.10. Ballast pick up
- Clause 4.2.3.11 of this TSI details the specifications concerning the rolling stock related to ballast pick up. The corresponding specifications concerning the rules for speed reduction, when required, are set out in clause 4.2.1.2.2.3 of the Operation TSI 2006.
- 4.3.5.11. Braking performance
- Clause 4.2.4.1 of this TSI details the specifications concerning the rolling stock related to braking performance. The corresponding specifications concerning the rules for use of the brake are set out in clauses 4.2.2.5.1, 4.2.2.6.1 and 4.2.2.6.2 of the Operation TSI 2006.
- 4.3.5.12. Brake system requirements
- Clause 4.2.4.3 of this TSI details the specifications concerning the rolling stock related to brake system requirements. The corresponding specifications concerning the rules for use of the brake are set out in clauses 4.2.2.5.1, 4.2.2.6.1 and 4.2.2.6.2 of the Operation TSI 2006.
- 4.3.5.13. Eddy current brakes
- Clause 4.2.4.5 of this TSI details the specifications concerning the rolling stock related to eddy current brakes. The corresponding specifications concerning the rules for use of the eddy current brakes are set out in clause 4.2.2.6.2 of the Operation TSI 2006.

4.3.5.14. Protection of an immobilised train

Clause 4.2.4.6 of this TSI details the specifications concerning the rolling stock related to protection of an immobilised train. The corresponding specifications concerning the rules for securing the train when the parking brake is not sufficient are set out in clause 4.2.2.6.2 of the Operation TSI 2006.

4.3.5.15. Brake performance on steep gradients

Clause 4.2.4.7 of this TSI details the specifications concerning the rolling stock related to brake performance on steep gradients. The corresponding specifications concerning the rules for speed restrictions are set out in clauses 4.2.1.2.2.3 and 4.2.2.6.2 of the Operation TSI 2006.

4.3.5.16. Public address system

Clause 4.2.5.1 of this TSI details the specifications concerning the rolling stock related to public address system. There is no specification concerning the rules for use of the public address system in the Operation TSI 2006.

4.3.5.17. Passenger alarm

Clause 4.2.5.3 of this TSI details the specifications concerning the rolling stock related to passenger alarm. The corresponding specifications are set out in clause 4.2.2.4 of the Operation TSI 2006.

4.3.5.18. Environmental conditions

Clause 4.2.6.1 of this TSI details the specifications concerning the rolling stock related to environmental conditions. The corresponding specifications concerning the rules for admission of rolling stock not compliant with the actual environmental conditions are set out in clauses 4.2.2.5 and 4.2.3.3.2 of the Operation TSI 2006.

4.3.5.19. Train aerodynamic loads in open air

Clause 4.2.6.2 of this TSI details the specifications concerning the rolling stock related to train aerodynamic loads in open air. There is no specification concerning the safety rules for track workers or passengers on platforms in the Operation TSI 2006.

4.3.5.20. Crosswind

Clause 4.2.6.3 of this TSI details the specifications concerning the rolling stock related to crosswind. The corresponding specifications concerning the rules for speed restriction when needed are set out in clauses 4.2.1.2.2.3 and 4.2.3.6 of the Operation TSI 2006.

4.3.5.21. Maximum pressure variations in tunnels

Clause 4.2.6.4 of this TSI details the specifications concerning the rolling stock related to maximum pressure variations in tunnels. The corresponding specifications concerning the rules for speed restriction when needed are set out in clauses 4.2.1.2.2.3 and 4.2.3.6 of the Operation TSI 2006.

4.3.5.22. Exterior noise

Clause 4.2.6.5 of this TSI details the specifications concerning the rolling stock related to exterior noise, which is dependent of operation conditions. The corresponding specifications are set out in clause 4.2.3.7 of the Operation TSI 2006.

4.3.5.23. Emergency exits

Clause 4.2.7.1 of this TSI details the specifications concerning the rolling stock related to emergency exits. The corresponding specifications are set out in clauses 4.2.3.6 and 4.2.3.7 of the Operation TSI 2006.

- 4.3.5.24. Fire safety
- Clause 4.2.7.2 of this TSI details the specifications concerning the rolling stock related to fire safety. The corresponding specifications concerning the procedures in case of fire on board are set out in clauses 4.2.3.6 and 4.2.3.7 of the Operation TSI 2006.
- 4.3.5.25. External lights and horn
- Clause 4.2.7.4 of this TSI details the specifications concerning the rolling stock related to external lights and horn. The corresponding specifications concerning the rules for use of external lights and horn are set out in clauses 4.2.2.1.2, 4.2.2.1.3 and 4.2.2.2 of the Operation TSI 2006.
- 4.3.5.26. Lifting/rescue procedures
- Clause 4.2.7.5 of this TSI details the specifications concerning the rolling stock related to lifting/rescue procedures. The corresponding specifications concerning the rules for lifting/rescue procedures are set out in clause 4.2.3.7 of the Operation TSI 2006.
- 4.3.5.27. Interior noise
- Clause 4.2.7.6 of this TSI details the specifications concerning the rolling stock related to interior noise, which is dependent of operation conditions. There is no specification in the Operation TSI 2006.
- 4.3.5.28. Air conditioning
- Clause 4.2.7.7 of this TSI details the specifications concerning the rolling stock related to air conditioning. There is no specification concerning the rules for interrupting the fresh airflow in the Operation TSI 2006.
- 4.3.5.29. Driver's vigilance device
- Clause 4.2.7.8 of this TSI details the specifications concerning the rolling stock related to driver's vigilance device. The corresponding specifications are set out in clauses 4.3.3.2 and 4.3.3.7 of the Operation TSI 2006.
- 4.3.5.30. Monitoring and diagnostic concepts
- Clause 4.2.7.10 of this TSI details the specifications concerning the rolling stock related to monitoring and diagnostic concepts. Additional requirements are set out in clause 4.2.3.5.2 and annexes H and J of the Operation TSI 2006.
- 4.3.5.31. Particular specification for tunnels
- Clause 4.2.7.11 of this TSI details the specifications concerning the rolling stock related to particular specification for tunnels. The corresponding specifications concerning the procedures for preventing inhalation of fumes in the event of a fire in close proximity to the train are set out in clauses 4.2.1.2.2.1, 4.2.3.7 and 4.6.3.2.3.3 of the Operation TSI 2006.
- 4.3.5.32. Traction performance requirements
- Clause 4.2.8.1 of this TSI details the specifications concerning the rolling stock related to traction performance requirements. The corresponding specifications concerning the procedures for taking this performance into consideration are set out in clauses 4.2.2.5 and 4.2.3.3.2 of the Operation TSI 2006.
- 4.3.5.33. Traction wheel/rail adhesion requirements
- Clause 4.2.8.2 of this TSI details the specifications concerning the rolling stock related to traction wheel/rail adhesion requirements. The corresponding specifications concerning the procedures in case of degraded wheel/rail adhesion condition are set out in clauses 4.2.3.3.2, 4.2.3.6 and 4.2.1.2.2 and in clause C of annex B of the Operation TSI 2006.

4.3.5.34. Functional and technical specification related to power supply

Clause 4.2.8.3 of this TSI details the specifications concerning the rolling stock related to power supply. The corresponding specifications concerning the procedures in case of degraded situation of the power supply system, the rules for the use of pantographs and the rules to be applied when running through phase or system separation sections are set out in clauses 4.2.3.6 and 4.2.1.2.2 and in annex H of the Operation TSI 2006.

4.3.5.35. Servicing

Clause 4.2.9 of this TSI details the specifications concerning the rolling stock related to servicing. There is no specification concerning the procedures for servicing in the Operation TSI 2006.

4.3.5.36. Vehicle identification

Clause 4.2.7.15 of this TSI details the specifications concerning the rolling stock related to vehicle identification. The corresponding specifications concerning the rules for identification of the vehicle are set out in clause 4.2.2.3 of the Operation TSI 2006.

4.3.5.37. Signal sighting

Clause 4.2.2.6 of this TSI details the specifications concerning the external visibility for the driver. The specifications concerning the corresponding operating rules are set out in clauses 4.3.1.1, 4.3.2.4 and 4.3.3.6 of the Operation TSI 2006.

4.3.5.38. Emergency exits

Clause 4.2.7.1 of this TSI details the specifications concerning the emergency exits. The corresponding specifications are set out in clause 4.2.2.4 of the Operation TSI 2006.

4.3.5.39. Driver-Machine-Interface (DMI)

Clause 4.2.7.14 of this TSI details the specifications concerning the European Traffic Control System display for driving cabs. The specifications concerning the corresponding operating rules are set out in clause 4.3.2.3 and Annex A1 of the Operation TSI 2006.

4.4. **Operating rules**

In light of the essential requirements in Section 3, the operating rules specific to the high-speed rolling stock concerned by this TSI are those that are listed in clause 4.3.5 above.

The following operating rules do not form any part of the assessment of rolling stock.

The operating conditions for degraded mode form part of the safety management systems of a railway undertaking (see clause 4.2.1a)

In addition, operating rules shall be enforced to ensure that a train stopped in a gradient as specified in clause 4.2.4.6 of this TSI (Protection of an immobilised train) will be immobilised by mechanical means by the staff before the end of the two hour period.

Rosters shall take into account the needs for servicing and scheduled maintenance.

The rules for use of the public address system, the passenger alarm and the emergency exits, as well as for the operation of the access doors and of the air conditioning flaps, shall be elaborated by the railway undertaking.

The safety rules for track workers or passengers on platforms shall be elaborated by the infrastructure manager.

The operation conditions shall be set out by the railway undertaking in order that the noise level within the driver's cab is kept within the limit prescribed by the of Directive 2003/10/EC of the European Parliament and the Council of 6 February 2003 on the minimum health and safety requirements regarding the exposure of workers to the risks arising from physical agents (noise), according to the characteristics of the rolling stock as specified in clause 4.2.7.6 of this TSI.

The specifications concerning the procedures for assistance to persons of reduced mobility are an open point, pending the availability of the Conventional Rail TSI for accessibility to PRM.

The seals for the emergency handle shall be replaced after use.

Procedures for lifting and rescue shall be established by the railway undertaking that describe the method as well as the means of recovering a derailed train or a train that is unable to move normally.

4.5. **Maintenance rules**

In light of the essential requirements in section 3, the maintenance rules specific to the high-speed rolling stock subsystem concerned by this TSI are described in clauses:

- 4.2.3.3.1 Electrical resistance of wheelsets
- 4.2.3.3.2.1 Axle bearing health monitoring for Class 1 trains
- 4.2.3.3.2.2 Axle bearing health monitoring for those Class 2 trains requiring hot axle box detection
- 4.2.3.4.8 In service values of equivalent conicity
- 4.2.7.3 Protection against electric shock

and in particular in clauses:

- 4.2.9 Servicing
- 4.2.10 Maintenance.

The maintenance rules shall be such as to enable the rolling stock to pass the assessment criteria specified in Section 6 throughout its lifetime.

The party responsible for the management of the maintenance file as defined in clause 4.2.10 shall define the tolerances and intervals appropriately to ensure ongoing compliance. It is also responsible for deciding the in-service values when not specified in this TSI.

This means the assessment procedures described in section 6 of this TSI shall be fulfilled for type approval, and are not necessarily appropriate for maintenance. Not all tests may be made at every maintenance event and may be subject to wider tolerances.

The combination of the above assures continuous compliance with the essential requirements through the life of the rolling stock.

4.6. **Professional competencies**

The professional competencies required for the operation of the high-speed rolling stock will be covered by the High Speed Operation TSI 2006.

The competence requirements for the maintenance of the high-speed rolling stock shall be detailed in the maintenance documentation (see clause 4.2.10.2.2).

4.7. **Health and safety conditions**

The provisions for health and safety in respect of noise, vibration and air conditioning for staff in service compartments shall be no different from the minimum provision made for passengers.

Apart from requirements specified in clauses 4.2.2.6 (driver's cab), 4.2.2.7 (Windscreen and front of the train), 4.2.7.1.2 (driver's cab emergency exit), 4.2.7.2.3.3 (Fire resistance), 4.2.7.6 (interior noise) and 4.2.7.7 (air conditioning) and in the maintenance plan (see clause 4.2.10), there are no additional requirements related to health and safety for maintenance or operations staff in this TSI.

4.8. **Infrastructure and rolling stock registers**

4.8.1. Infrastructure register

The requirements for the high-speed rail infrastructure register content with regard to the high-speed rolling stock subsystem are specified in the following clauses:

- 1.2 Geographical scope
- 4.2.3.4.3 Track loading limit values
- 4.2.3.6 Maximum gradients
- 4.2.3.7 Maximum curve radius
- 4.2.4.1 Minimum braking performance
- 4.2.4.3 Brake system requirements
- 4.2.4.5 Eddy current brakes
- 4.2.4.7 Brake performance on steep gradients
- 4. 2.6.1 Environmental conditions
- 4.2.6.6.1 Interference generated on the signalling system and the telecommunications network
- 4.2.7.7 Air conditioning
- 4.2.8.3 Characteristics of the electrical supply
- 4.3.2.3 Kinematic gauge
- 4.3.2.7 Maximum train length
- 4.3.2.8 Maximum gradients
- 4.3.2.9 Minimum curve radius
- 4.3.2.12 Eddy current brake
- 4.3.2.13 Brake performance on steep gradients
- 4.3.2.14 Passenger alarm
- 4.3.2.20 Fire safety
- 4.3.2.22 Particular specification for tunnels
- 4.3.3.2 Brake system requirements
- 4.3.4.6 Braking performance

The infrastructure manager is responsible for the accuracy of the data provided for inclusion in the infrastructure register.

4.8.2. Rolling stock register

The rolling stock register shall contain the following mandatory data for all high-speed rolling stock, which are in accordance with this TSI as listed in Annex I.

If the Member State of registration changes, the contents of the rolling stock register for that high-speed rolling stock shall be passed from the original State of registration to the new State of registration.

The data contained in the rolling stock register is required by:

- The Member State to confirm that the high-speed rolling stock meets the requirements in accordance with this TSI
- The infrastructure manager to confirm that the high-speed rolling stock is compatible with the infrastructure over which it is intended to operate
- The railway undertaking to confirm that the high-speed rolling stock is suitable for its traffic requirements.

5. INTEROPERABILITY CONSTITUENTS

5.1. Definition

According to Article 2(d) of Directive 96/48/EC modified by Directive 2004/50/EC, the interoperability constituents are 'any elementary component, group of components, subassembly or complete assembly of equipment incorporated or intended to be incorporated into a subsystem, upon which the interoperability of the trans-European high-speed rail system depends either directly or indirectly.

The concept of a constituent covers both tangible objects and intangible objects such as software".

Interoperability constituents described in section 5.3 are constituents, whose technology, design, material, manufacturing and assessment processes are defined and enable their specification and assessment independently of the related subsystem, according to Annex IV of Directive 96/48/EC modified by Directive 2004/50/EC.

5.2. Innovative solutions

As stated in section 4 of this TSI, innovative solutions may require new specification and/or new assessment methods. These specifications and assessment methods shall be developed by the process described in clause 6.1.4.

5.3. List of constituents

The interoperability constituents are covered by the relevant provisions of Directive 96/48/EC modified by Directive 2004/50/EC and are listed below:

Automatic centre buffer couplers

Buffing and draw gear components

Towing couplers for recovery and rescue

Driver's cab windscreens

Wheels

Headlamps

Marker lamps

Tail lamps
Horns
Pantographs
Contact strips
Connections for toilet discharge systems
Mobile discharge trolleys
Water filling adapters

5.4. **Constituents performance and specifications**

The characteristics to be respected by high-speed rolling stock are given in the relevant clauses of section 4.2 indicated below:

Automatic centre buffer couplers [clause 4.2.2.2.2.1]
Buffing and draw gear components [clause 4.2.2.2.2.2]
Towing couplers for recovery and rescue [clause 4.2.2.2.2.3]
Driver's cab windscreens [clause 4.2.2.7]
Wheels [clause 4.2.3.4.9.2
clause H.2 of Annex H]
Marker lamps [clause H.2 of Annex H]
Tail lamps [clause H.3 of Annex H]
Horns [clause 4.2.7.4.2.5
clause 4.2.8.3.7]
Contact strips [clause 4.2.8.3.8]
Connections for toilet discharge systems [Annex M VI]
Mobile discharge trolleys [clause 4.2.9.3.2]
Water filling adapters [clause 4.2.9.5.2].

6. **ASSESSMENT OF CONFORMITY AND/OR SUITABILITY FOR USE**

6.1. **Interoperability constituents of the rolling stock subsystem**

6.1.1. Conformity assessment (general)

An EC declaration of conformity or an EC declaration of Suitability for Use in accordance with Article 13(1) and Annex IV Chapter 3 of Directive 96/48/EC modified by Directive 2004/50/EC shall be drawn up by the manufacturer or his authorised representative established within the Community before placing an interoperability constituent on the market.

The Conformity Assessment of an Interoperability Constituent shall be done according to the following modules. (The modules are described in Annex F to this TSI):

Modules for interoperability constituents:

Module A:	Internal production control for design, development and production phases
Module A1:	Internal design control with product verification for design, development and production phases
Module B:	Type examination for design and development phases
Module C:	Conformity to type for production phase
Module D:	Production quality management system for production phase
Module F:	Product verification for production phase
Module H1:	Full quality management system for design, development and production phases
Module H2:	Full quality management system with design examination for design, development and production phases
Module V:	Type validation by in service experience (Suitability for use)

If the participation of a notified body is required for the appropriate module,

- The approval process and the contents of the assessment shall be defined between the manufacturer or his authorised representative established within the Community and a notified body, according to the requirements defined in this TSI.
- For each interoperability constituent as appropriate the notified body to be chosen by the manufacturer shall have been authorised either
 - To assess the interoperability constituents of the high-speed rolling stock subsystem or
 - To assess the pantograph and contact strip interoperability constituents of the high-speed energy subsystem, where relevant.

There is provision in clause 6.3 for dealing with the transitional arrangements for interoperability constituents to be used without certification.

6.1.2. Conformity assessment procedures (modules)

The conformity assessment shall cover the phases and characteristics as indicated by 'X' in Table D1 of Annex D to this TSI. The manufacturer or his authorised representative established within the Community shall choose one of the modules or module combinations indicated in the following Table 22 according to the required constituent.

Table 22

Assessment modules for interoperability constituents

Clause	Constituents to be assessed	Module A	Module A1 (*)	Module B+C	Module B+D	Module B+F	Module H1 (*)	Module H2
4.2.2.2.2.1	Automatic centre buffer couplers		X		X	X	X	X
4.2.2.2.2.2	Buffing and draw gear components		X		X	X	X	X
4.2.2.2.2.3	Towing coupler for recovery and rescue		X		X	X	X	X
4.2.2.7	Driver's cab windscreens		X		X	X	X	X
4.2.3.4.9.2	Wheels		X		X	X	X	X

Clause	Constituents to be assessed	Module A	Module A1 (*)	Module B+C	Module B+D	Module B+F	Module H1 (*)	Module H2
4.2.7.4.2	Horns		X	X	X		X	X
4.2.8.3.7	Pantographs		X		X	X	X	X
4.2.8.3.9	Contact strips		X		X	X	X	X
4.2.9.3.2	Mobile discharge trolleys	X		X			X	
4.2.9.5.2	Water filling adapters	X		X			X	
Annex H clause H.2	Head lamps		X	X	X		X	X
Annex H clause H.2	Marker lamps		X	X	X		X	X
Annex H clause H.3	Tail lamps		X	X	X		X	X
Annex M VI	Connections for toilet discharge system	X		X			X	

(*) Modules A1 and H1 are allowed for existing solutions only under conditions defined in clause 6.1.3

6.1.3. Existing solutions

If an existing solution for an interoperability constituent is already assessed for an application under comparable conditions and is on the market, then the following process applies:

The manufacturer or his authorised representative established within the Community shall demonstrate that the results of tests and verifications for the previous assessment of ICs are in conformity with the requirements of this TSI. In this case these tests and verifications shall remain valid for the new assessment. Modules A1 and H1 are permitted to be applied if they are marked in Table 22.

If it is not possible to demonstrate that the solution has been positively proven in the past, the manufacturer or his authorised representative established within the Community shall choose the assessment procedures according to the modules or module combinations indicated in Table 22. Modules A1 and H1 are not permitted to be applied even if they are marked in Table 22.

6.1.4. Innovative solutions

If an innovative solution is proposed for an interoperability constituent, as defined in section 5.2, the manufacturer or his authorised representative established within the Community shall state the deviations from the relevant clause of this TSI and submit them to the European Railway Agency (ERA). The ERA shall produce and finalise the appropriate functional and interface specifications for the constituents and develop the assessment methods.

The appropriate functional and interface specifications and the assessment methods so produced shall be incorporated in the TSI by the revision process.

After entry into force of a decision of the Commission, taken in accordance with Article 21(2) of Directive 96/48/EC, as modified by Directive 2004/50/EC, the innovative solution is permitted to be used before being incorporated into a TSI.

6.1.5. Assessment of suitability for use

Assessment of Suitability for Use according to the type validation of in service experience procedure (module V) as indicated in Annex F of this TSI is required for the following interoperability constituents:

- Wheels
- End Couplers

6.2. Rolling stock subsystem

6.2.1. Conformity assessment (general)

In accordance with Annex VI of the Directive 96/48/EC, the contracting entity, or its authorised representative established within the Community shall lodge an application for assessment of conformity of the high-speed rolling stock subsystem and energy subsystem, where relevant, with a notified body of its choice.

This notified body shall have been authorised to assess the high-speed rolling stock subsystem and if required to assess the high-speed energy subsystem. Where it is not authorised to assess the high-speed energy subsystem it shall, if required, contract arrangements with another notified body notified for assessment of the energy subsystem for the assessment of the relevant requirements concerning the on-board part of the energy subsystem (see sections 4.2.8.3, 4.3.3.4 of this TSI).

The EC declaration(s) of verification in accordance with Article 18(1) and Annex VI of Directive 96/48/EC modified by Directive 2004/50/EC, one for the high-speed rolling stock subsystem, one for the on-board part of the energy subsystem if required, shall be drawn up by the applicant.

The EC declaration(s) of verification is/are required to obtain the authorisation to place rolling stock into service.

The Conformity Assessment of a Subsystem shall be performed according to one or a combination of the following modules according to clause 6.2.2 and annex E of this TSI (The modules are described in Annex F of this TSI):

Modules for the EC verification of subsystems

- Module SB: Type examination for design and development phases
- Module SD: Product quality management system for production phase
- Module SF: Product verification for production phase
- Module SH2: Full quality management system with design examination for design, development and production phases

The approval process and the contents of the assessment shall be defined between the applicant and a notified body according to the requirements defined in this TSI and in conformance with the rules set out in section 7 of this TSI.

6.2.2. Conformity assessment procedures (modules)

The applicant shall choose one of the modules or module combinations indicated in Table 23.

Table 23

Assessment modules for Subsystems

Subsystem to be assessed	Module SB+SD	Module SB+SF	Module SH2
Rolling stock subsystem	X	X	X
On-board part of the energy subsystem, where relevant	X	X	X

The characteristics of the rolling stock subsystem to be assessed during the relevant phases are indicated in Annex E, Table E1 of this TSI. The applicant shall confirm that each subsystem produced complies with the type. An 'X' in column 4 of table E1 in Annex E indicates that the relevant characteristics shall be verified by testing each single subsystem. The test body shall be determined according to the assessment module in use.

Characteristics of interoperability constituents that are indicated in Annex D, Table D1, also appear in Annex E, Table E1. Assessment of these characteristics is covered by the presence of the EC declaration of conformity and if applicable the EC declaration of suitability for use of the interoperability constituent. The assessment of the maintenance subsystem is described in clause 6.2.4.

6.2.3. Innovative solutions

If rolling stock includes an innovative solution as defined in section 4.1, the manufacturer or the contracting entity shall state the deviation from the relevant clause of the TSI and submit them to the European Railway Agency (ERA). The ERA shall finalise the appropriate functional and interface specifications of this solution and develop the assessment methods.

The appropriate functional and interface specifications and assessment methods shall be incorporated in the TSI by the revision process.

After entry into force of a decision of the Commission, taken in accordance with Article 21(2) of Directive 96/48/EC, as modified by Directive 2004/50/EC, the innovative solution is permitted to be used before being incorporated into a TSI.

6.2.4. Assessment of maintenance

According to Article 18 (3) of the Directive 96/48/EC, modified by Directive 2004/50/EC, a notified body shall be presented with the maintenance file, which forms part of the technical file.

A notified body shall verify only that the information is contained in the maintenance file according to clause 4.2.10.2. The notified body is not required to verify the information contained.

The conformity assessment of maintenance is the responsibility of each Member State concerned.

Clause F.4 of Annex F (which is an open point) describes the procedure by which each Member State ascertains that maintenance arrangements meet the provisions of this TSI and ensure the basic parameters and essential requirements are met during the life of the rolling stock

6.2.5. Assessment of single vehicles

Where an assessment of a new, upgraded or renewed single vehicle is required according to the requirements of clause 4.2.1.2, and a valid type or design examination certificate of 'EC' verification for the other vehicles in the consist is available, a TSI assessment only for the new vehicle is required providing the trainset remains compliant to the TSI.

Where an assessment of a single vehicle is required according to the requirements of clause 4.2.1.2 and a valid type or design examination certificate of 'EC' verification for the other vehicles in the consist is not available, it is permitted to accept national certification for such other vehicles until type or design examination certification of 'EC' verification is available.

6.3. Interoperable Constituents Not Holding an EC Declaration

6.3.1. General

For a limited period of time, known as the 'transition period', interoperability constituents not holding an EC Declaration of Conformity or Suitability for Use may exceptionally be incorporated into subsystems, on the condition that the provisions described in this section are met.

6.3.2. The Transition Period

The transition period shall commence from the entry into force of this TSI and shall last for six years.

Once the transition period has ended, and with the exceptions allowed under section 6.3.3.3 below, interoperability constituents shall be covered by the required EC declaration of conformity and/or suitability for use before being incorporated into the subsystem;

6.3.3. The Certification of Subsystems Containing Non-Certified Interoperability Constituents during the Transition Period

6.3.3.1. Conditions

During the transition period a Notified Body is permitted to issue a certificate of conformity for a subsystem, even if some of the interoperability constituents incorporated within the subsystem are not covered by the relevant EC declarations of conformity and/or suitability for use according to this TSI, if the following three criteria are complied with:

- the conformity of the subsystem has been checked in relation to the requirements defined in chapter 4 of this TSI by the Notified Body, and
- through carrying out additional assessments the Notified Body confirms that the conformity and/or the suitability for use of the interoperability constituents is in accordance with the requirements of chapter 5, and
- the interoperability constituents, which are not covered by the relevant EC declaration of conformity and/or suitability for use, shall have been used in a subsystem already put in service in at least one of the Member States before the entry in force of this TSI.
 - EC Declarations of conformity and/or suitability for use shall not be drawn up for the interoperability constituents assessed in this manner.

6.3.3.2. Notification

- the certificate of conformity of the subsystem shall indicate clearly which interoperability constituents have been assessed by the Notified Body as part of the subsystem verification.
- the EC declaration of verification of the subsystem shall indicate clearly:
 - Which interoperability constituents have been assessed as part of the subsystem
 - Confirmation that the subsystem contains the interoperability constituents identical to those verified as part of the subsystem.
 - For those interoperability constituents, the reason(s) why the manufacturer did not provide an EC Declaration of conformity and/or suitability for use before its incorporation into the subsystem.

6.3.3.3. Lifecycle Implementation

The production or upgrade/renewal of the subsystem concerned must be completed within the six years of the transition period. Concerning the subsystem lifecycle:

- During the transition period and
- under the responsibility of the body having issued the declaration of EC verification of the subsystem

the interoperability constituents which do not hold an EC declaration of conformity and/suitability for use and are of the same type built by the same manufacturer are permitted to be used for maintenance related replacements and as spare parts for the subsystem.

After the transition period has ended and

- until the subsystem is upgraded, renewed or replaced and
- under the responsibility of the body having issued the declaration of EC verification of the subsystem

the interoperability constituents which do not hold an EC declaration of conformity and/suitability for use and are of the same type built by the same manufacturer may continue to be used for maintenance related replacements.

6.3.4. Monitoring Arrangements

During the transition period Member States shall monitor:

- The number and type of interoperability constituents introduced on the market within their own State;
- Ensure that, where a subsystem is presented for authorisation, reasons for non-certification of the interoperability constituent by the manufacturer are identified;
- Notify, to the Commission and to the other Member States, the details of the non-certified IC and the reasons for non-certification.

7. IMPLEMENTATION OF THE ROLLING STOCK TSI

7.1. Implementation of the TSI

7.1.1. Newly built rolling stock of new design

7.1.1.1. Definitions

For the purpose of this section 7.1.1 and of section 7.1.2.1:

- Phase A period is the period starting when a notified body is appointed and provided with a description of the rolling stock intended to be developed and built or acquired.
- Phase B period is the period starting when a type or design examination certificate of 'EC' verification is issued by a notified body, and ending when this type or design examination certificate of 'EC' verification ceases to be valid.

7.1.1.2. General

- The type or design examination certificate of 'EC' verification for subsystem and/or
- type or design examination certificate of conformity and/or suitability for use for interoperability constituents,

are permitted to be requested by any applicant as defined in clauses 6.2.1 and 6.1.1 respectively.

The applicant shall announce its intent for development and assessment of new rolling stock and/or IC to a notified body chosen in accordance with Chapter 6 of this TSI. Together with this announcement, the applicant shall provide a description of the rolling stock or of the IC it intends to develop and build or acquire.

7.1.1.3. Phase A

Following the date of appointment of the notified body, the certification basis to the currently valid TSI at the date of the appointment for the specified rolling stock shall be fixed for a seven year phase A period, except for specific requirements where Article 19 of Directive 96/48/EC as modified by Directive 2004/50/EC, is applied.

When a revised version, including this one, of the TSI comes into force during the phase A period it is permissible to use the revised version, either totally or for discrete sections, if both the applicant and the notified body agree to do so. These arrangements shall be documented.

After a positive assessment, a notified body shall issue the type or design examination certificate of 'EC' verification for the subsystem or the type or design examination certificate of conformity and/or suitability for use for the interoperability constituent.

7.1.1.4. Phase B

(a) Subsystem requirements

This type or design examination certificate for the subsystem is valid for a seven year phase B period even if a new TSI comes into force except in case of use of Article 19 of Directive 96/48/EC as modified by Directive 2004/50/EC. During this time, new rolling stock of the same type is permitted to be placed into service without a new type assessment.

Before the end of the seven year phase B period, rolling stock shall be assessed according to the TSI in force at that time for those requirements that have changed or are new in comparison to the certification basis.

- If a derogation is requested and accepted, the existing type or design examination certificate of 'EC' verification remains valid for another three year phase B period. Before the end of the three years the same process of assessment and application for derogation is permitted to take place again.
- If the design of the subsystem is compliant the type or design examination certificate of 'EC' verification shall remain valid for a further seven year phase B period.

In the event that no new TSI comes into force before the end of the phase B period, assessment of the rolling stock is not required and the relevant certification shall remain in force for a further seven year phase B period.

(b) Interoperability constituent requirement

The type or design examination or suitability for use certificate is valid for a five year phase B period even if a new TSI comes into force except in case of use of Article 19 of Directive 96/48/EC as modified by Directive 2004/50/EC. During this time, new constituents of the same type are permitted to be placed into service without an assessment.

Before the end of the five-year phase B period, constituent shall be assessed according to the TSI in force at that time for those requirements that have changed or are new in comparison to the certification basis.

If a derogation is requested and accepted, the existing type or design examination or suitability for use certificate of 'EC' verification remains valid for another three year phase B period. Before the end of the three years the same process of assessment and application for derogation is permitted to take place once more only.

7.1.2. Newly built rolling stock of an existing design certified to an existing TSI

The existing type or design examination certificate of 'EC' verification for the subsystem is valid for a seven year phase B period after its issue date even if a new TSI comes into force except for specific requirements where Article 19 of Directive 96/48/EC as modified by Directive 2004/50/EC, is applied. During this time, new rolling stock of the same type is permitted to be placed into service without a new type assessment.

Before the end of the seven year phase B period, rolling stock shall be assessed according to the TSI in force at that time for those requirements that have changed or are new in comparison to the certification basis.

- If a derogation is requested and accepted, the existing type or design examination certificate of 'EC' verification remains valid for a further three year phase B period. Before the end of the three years the same process of assessment and application for derogation is permitted to take place again.
- If the design of the subsystem is compliant the type or design examination certificate of 'EC' verification remains valid for a further seven-year phase B period.

In the event that no new TSI comes into force before the end of the phase B period, assessment of the rolling stock is not required and the relevant certification shall remain in force for a further seven year phase B period.

For interoperability constituents the process described in clause 7.1.1.4 is also valid for newly built rolling stock of an existing design certified to an existing TSI.

7.1.3. Rolling stock of an existing design

Rolling stock, whose design is not certified in accordance with the TSIs shall be subject to the conditions described in section 7.1.7.

Existing rolling stock is rolling stock which is already in service before this TSI enters into force.

This TSI does not apply to existing rolling stock as long as it is not renewed or upgraded.

7.1.4. Rolling stock being upgraded or renewed

In respect of rolling stock already in operation this section applies to existing high-speed trains and conventional rolling stock to be upgraded for high speed operation, as defined in Article 2 clause (l) and (n) of Directive 96/48 amended by Directive 2004/50/EC.

A new assessment against the requirements of the TSI that is in force at the date of request is required only for the modifications that are within the scope of this TSI.

Guidance for those modifications that are deemed to be upgrades or renewals is given below.

The following list indicates as informative guidance those modifications that necessitate reassessment of a vehicle design. This list is not exhaustive (the parameter changes quoted below are valid only if the total change remains within the limits of the TSI):

- Alterations to vehicle parameters affecting running performance beyond the simplified procedure (λ). λ is defined in clause 5.5.5 of EN14363:2005.
 - Fitting of new designs of spring, couplers, active vehicle/car-body steering mechanisms etc.
 - Exceeding the basic conditions for adoption of the simplified measuring procedure: The 'non-existence' of a safety factor ($\lambda \geq 1,1$ meaning that the evaluated results are at least 10 % off the safety-related limit values.
 - Alterations to operating, vehicle and running gear parameters in excess of the tolerances set out in Table 3 of EN14363:2005 'Railway applications — ride testing for the approval of rolling stock — testing of ride behaviour and stationary tests'.
- Raising V_{\max} by more than 10 km/h
- Alteration of total vehicle weight by more than 10 %
- Raising of static axle load by more than 1,5 t
- Alteration of concepts for
 - Emergency exits
 - Fire safety
 - Occupational safety and environmental protection
 - On board train control and management systems inclusive of the applicable software

7.1.5. Noise

7.1.5.1. Transitional period

It is allowable to apply limits 2 dB(A) higher than those stated in section 4 and clause 7.3 of this TSI for external noise from rolling stock within the scope of this TSI within a transitional period of 24 months starting from the date of entry into force of this TSI. This allowance is restricted to the case of:

- contracts already signed or under the final phase of the tendering procedure at the date of entry into force of this TSI, and options to these contracts to purchase additional vehicles, or
- contracts for purchasing new rolling stock of an existing design type signed during this transitional period.

The transitional period of 24 months is extended to 60 months in the case of DMUs where the power per diesel engine is more than or equal to 500 kW.

7.1.5.2. Upgrading or renewal of rolling stock

It has only to be proved that an upgraded or renewed vehicle does not increase noise with respect to the performance of the vehicle before upgrading or renewal.

7.1.5.3. A two step approach

It is recommended that in the case of new rolling stock to be ordered after 1 January 2010 Section 4.2.1.1 and Section 4.2.6.5.4 of this TSI is applied with a reduction of 2 dB(A) at a speed of 250km/h, and 3 dB(A) at speeds of 300km/h and 320km/h. This recommendation will serve only as a basis for revising section 4.2.6.5.4 in the context of the TSI revision process mentioned in section 7.1.10

7.1.6. Mobile toilet discharge trolleys [clause 4.2.9.3]

First step: the infrastructure manager and the railway undertaking examine together the rolling stock roster project proposed by the railway undertaking, and identify the areas of the interoperable network, on the route under consideration, where it should be possible (according to this rolling stock roster project) to discharge the train toilets when needed, and where there are not (or not enough) toilet emptying fixed facilities allowing this operation on those trains.

Second step: the infrastructure manager and the railway undertaking carry out together an economic study leading to modifications of the rolling stock roster. Those modifications, regarding the number and/or the location of the areas where it will be possible to discharge the train toilets when needed, minimise the number of mobile toilet discharge trolleys (complying with this TSI) that will have to be placed on those areas.

7.1.7. Measures to prevent fire — material conformity

Pending publication of EN45545-2 or of an annex to this TSI, conformity with the requirement in clause 4.2.7.2.2 shall be deemed to be satisfied by the verification of conformity to the material fire safety requirements of the notified national rules (using the appropriate operation category) from one of the following sets of standards:

- the British standards BS6853, GM/RT2120 issue 2 and AV/ST9002 issue 1;
- the French standards NF F 16-101:1988 and NF F 16-102/1992;
- the German standard DIN 5510-2:2003 including toxicity measurements, fire safety category 2 (standard currently being supplemented by requirements for toxicity; toxicity requirements from other standards may be utilised as appropriate until the supplement is completed)

- the Italian standards UNI CEI 11170-1:2005 and UNI CEI 11170-3:2005.
- the Polish standards PN-K-02511:2000 and PN-K-02502:1992.

7.1.8. Rolling stock operating under national, bilateral, multilateral or international agreements

7.1.8.1. Existing agreements

Member States shall notify the Commission, within 6 months after the entry into force of this TSI, of the following agreements under which rolling stock related to the scope of this TSI (construction, renewal, upgrading, placing in service, operation and management of rolling stock as defined in chapter 2 of this TSI) are operated:

- national, bilateral or multilateral agreements between Member States/Safety Authorities and railway undertakings or infrastructure managers, agreed on either a permanent or temporary basis;
- bilateral or multilateral agreements between railway undertakings, infrastructure managers or between Member States/Safety Authorities;
- international agreements between one or more Member States and at least one third country, or between railway undertakings or infrastructure managers of Member States and at least one railway undertaking or infrastructure manager of a third country;

Continued operation/maintenance of rolling stock covered by these agreements shall be permitted as far as they comply with Community legislation.

The compatibility of these agreements with EU legislation including their non-discriminatory character, and this TSI, will be assessed by the European Rail Agency and the Commission will take the necessary measures such as, for example, the revision of this TSI to include possible specific cases or transitional measures.

The RIC Agreement shall not be notified because it is known.

7.1.8.2. Future agreements

Any future agreement or modification of existing agreements, in particular those which include the procurement of rolling stock whose design is not certified in accordance with the TSIs, shall take into account EU legislation and this TSI. Member States shall notify the Commission of such agreements/modifications. The same procedure as set out in clause 7.1.7.1 then applies.

7.1.9. TSI revision

In conformity with Article 6(3) of Directive 96/48/EC as modified by Directive 2004/50/EC, the Agency shall be responsible for preparing the review and updating of TSIs and making appropriate recommendations to the Committee referred to in Article 21 of this Directive in order to take account of developments in technology or social requirements. In addition, the progressive adoption and revision of other TSIs may also impact this TSI. Proposed changes to this TSI shall be subject to rigorous review and updated TSIs will be published on an indicative periodic basis of 3 years.

The Agency shall be notified of any innovative solutions being considered by an applicant according to section 6.1.4 or 6.2.3, or by notified bodies when the applicant failed to do so in order to determine its future inclusion within the TSI.

Then the Agency shall proceed according to section 6.1.4 or 6.2.3.

7.2. **Compatibility of rolling stock with other subsystems**

The implementation of the High Speed Rolling Stock TSI shall comply with the requirement of full compatibility between the rolling stock and the fixed installations, including infrastructure, energy and control-command of the trans-European high-speed network

Following this, the implementation methods and phases concerning rolling stock depend on the following conditions:

- the progress of implementation of the High-Speed Infrastructure, Energy, Control-Command and Signalling and Operation TSIs,
- the rolling stock operational schemes (rosters)

The migration strategy for the on-board control-command system is described in the Control-Command and Signalling TSI 2006 clause 7.2.2.5.

The tools to ensure the technical compatibility requirements as well as to take into account the fore-mentioned conditions are:

- The infrastructure register;
- The rolling stock register.

7.3. **Specific cases**

7.3.1. General

The following special provisions are authorised in the following specific cases.

These specific cases are classified according to two categories: the provisions apply either permanently ('P' cases), or temporarily ('T' cases). It is recommended that the target system of the temporary cases is achieved either by 2010 ('T1' cases), an objective set in European Parliament and Council Decision No 1692/96/EC of 23 July 1996 on Community guidelines for the development of the trans-European transport network, or by 2020 ('T2' cases).

7.3.2. List of specific cases

7.3.2.1. General specific case on the 1 524 mm gauge network

Specific case for Finland:

Category 'P'- permanent

In the territory of Finland and at Swedish cross-border station Haparanda (1 524 mm), the bogies, wheelsets and other track gauge interfaces related interoperability constituents or/and subsystems built for track gauge 1 524 mm network are only accepted, if they comply with the following mentioned Finnish specific cases for track gauge interfaces. Without prejudice to the above-mentioned restriction (1 524 mm gauge) all the interoperability constituents and/or subsystems complying with the TSI requirements for 1 435 mm track gauge are accepted at Finnish cross-border station Tornio (1 435 mm) and at train-ferry harbours on the tracks for 1 435 mm.

7.3.2.2. End couplers and coupling arrangements to rescue trains [clause 4.2.2.2]

Specific case for Finland:

Category 'P'- permanent

The distance between buffer centrelines is permitted to be 1 830 mm. Alternatively, it is permitted that this rolling stock be equipped with SA-3 couplers with or without side buffers.

Where the distance between the buffer centrelines is 1 790 mm, the width of the buffer plates shall be increased by 40 mm towards the outside.

7.3.2.3. Passenger step [clause 4.2.2.4.1]

Note: specific cases from the PRM TSI will be incorporated here later.

7.3.2.4. Vehicle gauge [clause 4.2.3.1]

Specific case for Finland:

Category 'P'- permanent

Rolling stock intended for operation in Finland (1 524 mm) shall comply with gauge FIN 1 as defined in Annex R

Specific case for lines in Great Britain:

Category 'P'- permanent

Trains designed for running on upgraded lines in Great Britain shall comply with gauge 'UK1 (issue2)' as defined in Annex C to this TSI.

Specific case for trains running on Ireland and Northern Ireland networks:

Category 'P'- permanent

The gauge of trains designed for running on lines of the Ireland and Northern Ireland networks shall be compatible with the Irish standard structure gauge.

7.3.2.5. Vehicle mass [clause 4.2.3.2]

Specific case France:

Category 'P'- permanent

This specific case is specified in clause 3.1.4 of Annex A Appendix 1 of the Control-Command and Signalling TSI 2006

Specific case Belgium high-speed TEN (except 'L1'):

Category 'P'- permanent

This specific case is specified in clause 3.1.5 of Annex A Appendix 1 of the Control-Command and Signalling TSI 2006.

7.3.2.6. Electrical resistance of wheelsets [clause 4.2.3.3.1]

Specific case Poland:

Category 'P'- permanent

This specific case is specified in clause 3.5.2 of Annex A Appendix 1 of the Control-Command and Signalling TSI 2006.

Specific case France:

Category 'P'- permanent

This specific case is specified in clause 3.5.3 of Annex A Appendix 1 of the Control-Command and Signalling TSI 2006

Specific case Netherlands:

Category 'P'- permanent

This specific case is specified in clause 3.5.4 of Annex A Appendix 1 of the Control-Command and Signalling TSI 2006.

Specific case on the 1520/1524 mm gauge network

Category 'P'- permanent

This specific case is specified in clause 6.4 of Annex A Appendix 1 of the Control-Command and Signalling TSI 2006.

7.3.2.7. Hot axle box detection for Class 2 trains [clause 4.2.3.3.2.3]

Specific case for Finland:

Category 'P'- permanent

Functional requirements for the vehicle

Mutual agreement between the infrastructure-manager and the railway undertaking is requested to identify trains by train identification systems and use of specific alarm trigger levels. Specific alarm trigger levels shall be listed in the rolling stock register

Transverse dimensions of the target area

For rolling stock intended to be used on Finnish network (1 524mm track gauge) the target areas on the underside of an axle box that shall remain un-obstructed to permit observation by a trackside HABD shall be the following:

- minimum uninterrupted length of 50mm within a transverse minimum distance from the wheelset-centre of 1 020mm and a maximum transverse distance from the wheelset centre of 1 140mm
- minimum uninterrupted length of 15mm within a transverse minimum distance from the wheelset-centre of 885mm and a maximum transverse distance from the wheelset centre of 903mm

Longitudinal dimension of the target area

The longitudinal dimension on the underside of the axle box that shall remain unobstructed to permit observation by a trackside HABD (see figure below) shall:

- be centred on the wheelset's centreline,
- have a minimum length L (mm) = 200mm

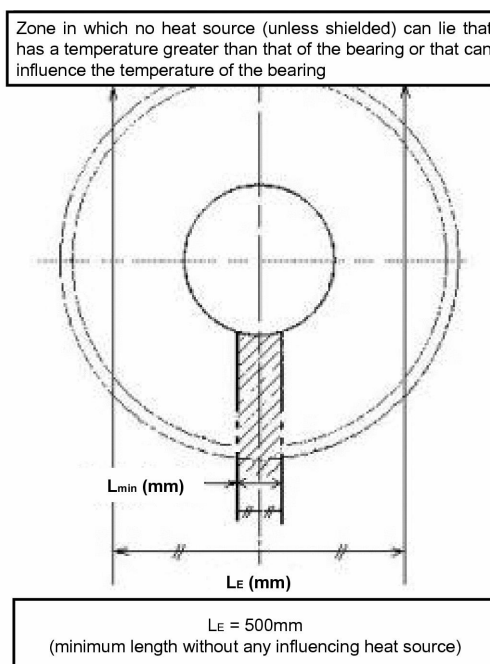

- 7.3.2.8. Wheel-rail contact (wheel profiles) [4.2.3.4.4]

Specific case for Finland:

Category 'P'- permanent

Wheelsets of trains designed for running on lines of the Finnish network shall be compatible with the track gauge of 1 524mm.

Specific case for trains running on Ireland and Northern Ireland networks:

Category 'P'- permanent

Wheelsets of trains designed for running on lines of the Ireland and Northern Ireland networks shall be compatible with the track gauge of 1 602mm.

- 7.3.2.9. Wheelsets [4.2.3.4.9]

Specific case for Finland:

Category 'P'- permanent

The dimensions for wheelsets and wheels related to 1 520 and 1 524 mm track gauges are given in Annex M Table M.2.

- 7.3.2.10. Maximum train length [4.2.3.5]

Specific case for Great Britain

Category 'P'- permanent

The High Speed Infrastructure TSI 2006 contains a specific case for the British network requiring platforms on upgraded lines to have a usable length of at least 300m. The actual length of platforms on upgraded lines in Great Britain where trains complying with the High Speed Rolling Stock TSI are intended to stop in normal commercial operation will be indicated in the infrastructure register. The length of high speed trains intended for operation on the British network shall be compatible with the length of the platforms at which they are intended to stop.

Specific case for Greece.

Category 'P' — permanent

The High Speed Infrastructure TSI 2006 contains a specific case for the Greek network requiring platforms on certain upgraded lines to have a usable length ranging from 150m to 300m as described in detail in said specific case.

The length of trains complying with the High Speed Rolling Stock TSI intended for operation on the Greek network shall be compatible with the length of the platforms at which they are intended to stop.

- 7.3.2.11. Sanding [4.2.3.10]

Specific case on the 1520/1524 mm gauge network

Category 'P'- permanent

This specific case is specified in clause 6. of Annex A Appendix 1 of the Control-Command and Signalling TSI 2006

7.3.2.12. Braking [clause 4.2.4]

7.3.2.12.1. General

Specific case for Finland:

Category 'P'- permanent

If the nominal speed exceeds 140 km/h at least one bogie shall be equipped with a magnetic track brake. If the nominal speed exceeds 180 km/h both bogies shall be equipped with magnetic track brakes. The track brakes in both cases shall be equipped with heating

The requirements set for the brake performance on steep gradients are not valid for vehicles for 1 524 mm gauge.

For vehicles used on 1 524 mm gauge, the parking brake shall be designed in such a way that fully loaded coaches shall be held on a gradient of 2,5 % with maximum wheel/rail adhesion of 0,15 with no wind.

7.3.2.12.2. Eddy current brakes [clause 4.2.4.5]

Specific case for Germany

Category 'P'- permanent

This specific case is specified in clause 5.2.3 of Annex A Appendix 1 of the Control-Command and Signaling TSI 2006

Specific case for Sweden

Category 'P'- permanent

The use of eddy current brakes for emergency braking or service braking is not allowed on the Swedish network.

7.3.2.13. Environmental conditions [clause 4.2.6.1]

Specific case for Finland, Sweden and Norway:

Category 'P'- permanent

Humidity

Sudden changes of the air temperature local to the vehicle shall be considered for a maximum variation of 60oK.

7.3.2.14. Train Aerodynamics

7.3.2.14.1. Aerodynamic loads on passengers on a platform [clause 4.2.6.2.2]

Specific case for UK

Category 'P' — Permanent

A full length train, running in the open air at $v = 200$ km/h, (or at its maximum operating speed if this is lower), shall not cause the air speed to exceed the value $u_{2\sigma} = 11,5$ m/s at a height of 1,2 m above the platform and at a distance of 3,0 m from the track centre, during the whole train passage (including the wake). The platform height used in the assessment shall be 915 mm or lower. All other testing conditions are as set out in 4.2.6.2.2.

7.3.2.14.2. Pressure loads in open air [clause 4.2.6.2.3]

Specific case for UK:

Category 'P'- permanent

On upgraded lines in the UK the maximum permissible pressure change (Δp_{20}) shall be 665 Pa for all trains.

7.3.2.14.3. Maximum pressure variations in tunnels [clause 4.2.6.4]

Specific case for Italy:

Category 'P'- permanent

To take account of the numerous tunnels with a cross-section of 54 m² which are traversed at 250 km/h, and those with a cross-section of 82,5 m² and traversed at 300 km/h, trains operating on the Italian network shall conform to the requirements set out in Table 24.

Table 24

Requirements for interoperable train in a solo-run in a non-inclined tube-like tunnel (Specific Case Italy)

Train type	Gauge	Reference Case		Criteria for the Reference Case			Allowed maximum speed [km/h]
		V_{tr} [km/h]	A_{tu} [m ²]	Δ_{pN} [Pa]	$\Delta_{pN} + \Delta_{pFr}$ [Pa]	$\Delta_{pN} + \Delta_{pFr} + \Delta_{pT}$ [Pa]	
$V_{tr,max} < 250$ km/h	GA or smaller	200	53,6	$\leq 1\ 750$	$\leq 3\ 000$	$\leq 3\ 700$	≤ 210
	GB	200	53,6	$\leq 1\ 750$	$\leq 3\ 000$	$\leq 3\ 700$	≤ 210
	GC	200	53,6	$\leq 1\ 750$	$\leq 3\ 000$	$\leq 3\ 700$	≤ 210
$V_{tr,max} < 250$ km/h	GA or smaller	200	53,6	$\leq 1\ 195$	$\leq 2\ 145$	$\leq 3\ 105$	< 250
	GB	200	53,6	$\leq 1\ 285$	$\leq 2\ 310$	$\leq 3\ 340$	< 250
	GC	200	53,6	$\leq 1\ 350$	$\leq 2\ 530$	$\leq 3\ 455$	< 250
$V_{tr,max} \geq 250$ km/h	GA or smaller	250	53,6	$\leq 1\ 870$	$\leq 3\ 355$	$\leq 4\ 865$	250
$V_{tr,max} \geq 250$ km/h	GA or smaller	250	63,0	$\leq 1\ 460$	$\leq 2\ 620$	$\leq 3\ 800$	> 250
	GB	250	63,0	$\leq 1\ 550$	$\leq 2\ 780$	$\leq 4\ 020$	> 250
	GC	250	63,0	$\leq 1\ 600$	$\leq 3\ 000$	$\leq 4\ 100$	> 250

If a trainset does not fulfil the values specified in Table 24, the operation rules for this train shall be determined by applying the published rules of the infrastructure manager.

7.3.2.15. Boundary characteristics linked to exterior noise [clause 4.2.6.5]

7.3.2.15.1. Limit for stationary noise [clause 4.2.6.5.2]

Specific case for UK and Ireland:

Category 'P'- permanent

For DMU's, the limit for stationary noise $L_{pAeq,T}$ shall be 77dB(A).

- 7.3.2.15.2. Limit for starting noise [clause 4.2.6.5.3]

Specific case for UK and Ireland:

Category 'P'- permanent

For electric locomotives with $P < 4500$ kW at the wheel rim, the maximum starting noise $L_{p\Delta F_{max}}$ shall be 84dB(A).

- 7.3.2.16. Fire extinguisher [clause 4.2.7.2.3.2]

Specific case for Italy:

Category 'T2'- temporary

To take into account the duration of the process of updating national regulations, it is permitted that domestic trains operating on the Italian network on national routes are equipped with portable dry powder extinguishers.

Portable dry powder extinguishers shall be adequate and sufficient and shall be placed at appropriate locations.

- 7.3.2.17. Horns [clause 4.2.7.4.2.1]

Specific case for Finland:

Category 'P'- permanent

Class 2 trains shall be fitted with horns with two distinct tones. The notes of the audible warning horns are intended to be recognisable as being from a train and not be similar to warning devices used in road transport or as factory or other common warning devices. Two separately sounded warning horns shall be used. The fundamental frequencies of the warning horn notes shall be:

- high note: 800 Hz \pm 20 Hz
- low note: 460 Hz \pm 20 Hz

Specific case for Italy:

Category 'T2'- temporary

To take into account the duration of the process of updating national regulations, it is permitted that domestic trains operating on the Italian network on national routes are equipped with horns with fundamental frequencies of:

- high note: 660 Hz \pm 15 Hz
- low note: 370 Hz \pm 10 Hz

The sound pressure level for these frequencies shall be between 120dB and 125dB using the measuring method described in clause 4.2.7.4.2.

- 7.3.2.18. Control-command and signalling system [clause 4.2.7.9]

- 7.3.2.18.1. Wheelset location [clause 4.2.7.9.2]

Specific case for Germany:

Category 'P'- permanent

This specific case is specified in clause 2.1.5 of Annex A Appendix 1 of the Control-Command and Signalling TSI 2006

Specific case for Poland and Belgium:

Category 'P'- permanent

This specific case is specified in clause 2.1.6 of Annex A Appendix 1 of the Control-Command and Signalling TSI 2006.

Specific case for France high-speed Trans European Network (TEN) and Belgium high-speed TEN 'L1' only:

Category 'P'- permanent

This specific case is specified in clause 2.1.8 of Annex A Appendix 1 of the Control-Command and Signalling TSI 2006.

Specific case for Belgium:

Category 'P'- permanent

This specific case is specified in clause 2.1.9 of Annex A Appendix 1 of the Control-Command and Signalling TSI 2006

Specific case on the 1520/1524 mm gauge network

Category 'P'- permanent

This specific case is specified in clause 6.2 of Annex A Appendix 1 of the Control-Command and Signalling TSI 2006.

7.3.2.18.2. Wheels [clause 4.2.7.9.3]

Specific case for Finland:

Category 'P'- permanent

Due to the Nordic climatic conditions, a specific wheel material is generally used in Finland and in Norway. It is similar to ER8 but with a level of manganese and silicon increased to improved properties against shelling. For domestic traffic this material may be used if agreed between the parties.

Specific case for France:

Category 'P'- permanent

This specific case is specified in clause 2.2.2 of Annex A Appendix 1 of the Control-Command and Signalling TSI 2006.

Specific case for Lithuania:

Category 'P'- permanent

This specific case is specified in clause 2.2.4 of Annex A Appendix 1 of the Control-Command and Signalling TSI 2006.

7.3.2.19. Pantograph [clause 4.2.8.3.6.]

Specific case for Finland:

Category 'P'- permanent

Trains operating on the Finnish network should be equipped with 1 950 mm pantograph. The profile of the pantograph head shall be as described below:

- Horn made of insulating material (projected length 200mm)
- Minimum length of the contact strip 1 100 mm
- Conducting range of collector head 1 550 mm
- Pantograph head length 1 950 mm

The normal height of the contact wire is 6 150 mm (min 5 600 mm, max 6 500 mm)

Pantograph heads shall have a maximum along track width of 400 mm.

Specific case for France:

Category T2

Copper and steel materials are permitted to be used for the contact strip on the DC network

Category P

Trains on DC lines are permitted to be equipped with a 1 950 mm wide pantograph heads.

Category P

High speed trains required to operate in France and Switzerland are permitted to be fitted with 1 450 mm wide pantographs heads.

Specific Case for Germany and Austria:

Category 'P' — permanent

The investment of changing the overhead line equipment on category II and III lines and in stations to meet the requirements of the 1 600 mm Euro pantograph is prohibitive. Trains traversing these lines shall be provided with secondary 1 950 mm pantographs for medium-speed operation up to 230 km/h so that the overhead line equipment on these parts of the trans-European network need not to be prepared for the operation of the Euro pantograph. In these areas a maximum lateral contact wire position of 550 mm is permissible related to the vertical on the track centre line under action of crosswind. Future studies concerning category II and III lines should take into account the Euro pantograph to demonstrate the relevance of the choices made.

Specific case for trains running on Great Britain network:

Category 'P'- permanent

For lines in Categories II and III, pantograph heads shall not have insulated horns, unless permitted for specific routes by an entry in the infrastructure register.

For lines in Categories II and III, the conducting range of the pantograph head shall be 1 300mm.

Pantographs shall have a working range of 2,1 m.

Pantograph heads shall have a maximum along track width of 400 mm.

Specific case for trains running on the Swedish network:

Category 'P' — permanent

Trains traversing category II and III lines shall be provided with secondary 1 800 mm pantographs for medium-speed operation up to 230 km/h

For traffic across the Öresund Bridge into Sweden, 1 950 mm pantographs are permitted.

Capacitive power factor is not allowed at voltages over 16,5 kV, due to the risk of making it hard or impossible for other vehicles to use regenerative braking because of too high a voltage on the overhead line.

In regeneration mode (electrical braking), the train shall not behave like a capacitor greater than 60 kVAr at any regenerated power, i.e. capacitive power factor is prohibited during regeneration. The exception of 60 kVAr capacitive reactive power is to allow the possibility to have filters on the high voltage side of the train/traction unit. These filters shall not exceed 60 kVAr capacitive reactive power at the fundamental frequency.

Specific case for trains running on the Spanish network:

Category 'P' — permanent

On some category II and III lines and in stations the 1 600mm Europantograph is not permitted. Trains traversing these lines shall be provided with secondary 1 950 mm pantographs for medium-speed operation up to 230 km/h.

The investment of changing the overhead contact line on category II and III lines and in stations to meet the requirements of the 1 600 mm Euro pantograph is prohibitive. Trains traversing these lines shall be provided with secondary 1 950 mm pantographs for medium-speed operation up to 230 km/h so that the overhead contact lines on these parts of the trans-European network needs not be prepared for the operation of the Euro pantograph. In these areas a maximum lateral contact wire position of 550 mm related to the vertical on the track centre line is permissible under action of crosswind. Future studies concerning category II and III lines shall take into account the Euro pantograph to demonstrate the relevance of the choices made.

Pantograph gauge envelope

For lines in Categories II and III, pantographs of vehicles used in Great Britain shall remain within the gauge defined in the diagram below. This is an absolute gauge, and not a reference profile subject to adjustments. The means of demonstrating compliance is an Open Point

The Pantograph Envelope

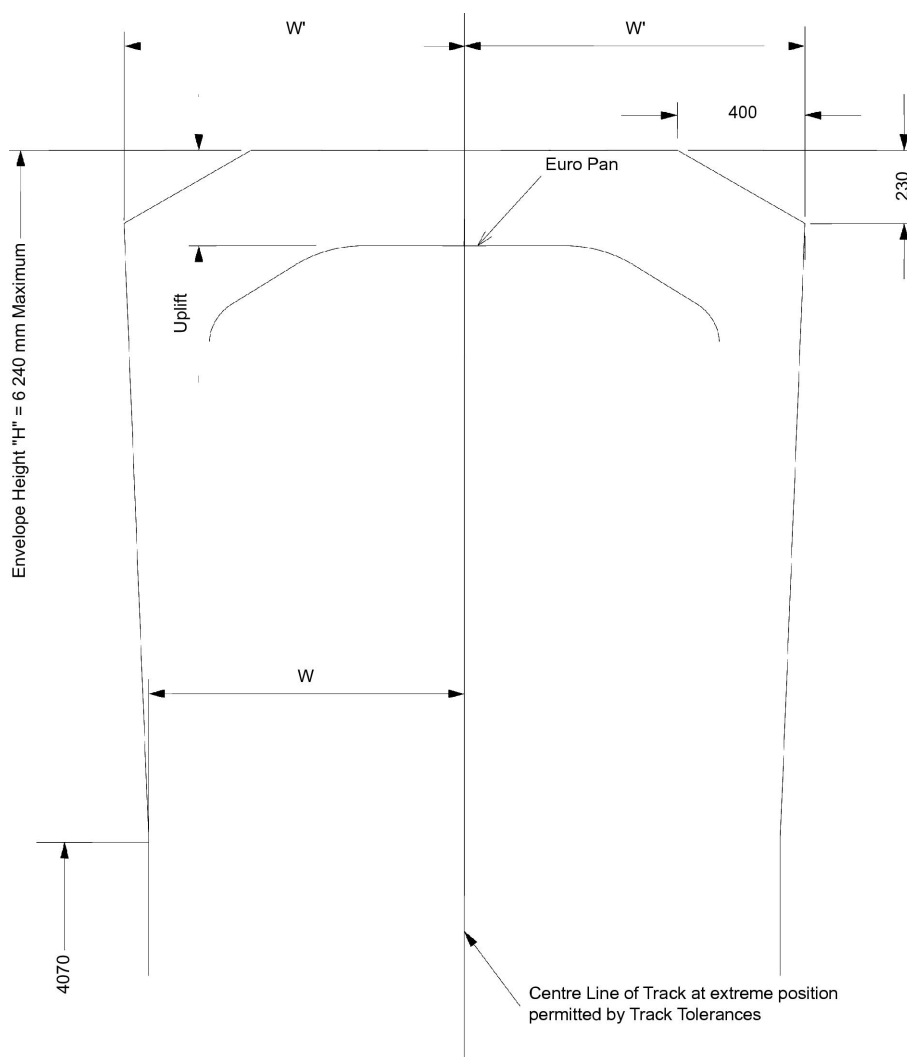

The diagram shows the extreme envelope within which movements of the pantograph head must remain. The envelope shall be placed on the extreme position of track centrelines permitted by track tolerances, which are not included. The envelope is not a Reference Profile.

At all speeds up to line speed; maximum cant; maximum wind speed at which unrestricted operation is possible, and extreme wind speed, defined in the register of infrastructure:

$W = 990$ mm, when $H \leq 4\,300$ mm;

and

$W' = 990 + (0,040 \times (H - 4\,300))$ mm, when $H > 4\,300$ mm.

Where:

H = Height to top of envelope above rail level (in mm). The dimension is the sum of the contact wire height and the provision for uplift.

Additional allowance shall be made for contact strip wear.

Specific case Italy:

Category 'P'- permanent

High speed trains required to operate in Italy and Switzerland are permitted to be fitted with 1 450 mm wide pantographs heads.

- 7.3.2.20. Interfaces with control-command and signalling system [clause 4.2.8.3.8]

Specific case Belgium:

Category 'P'- permanent

This specific case is specified in clause 3.6.1 of Annex A Appendix 1 of the Control-Command and Signalling TSI 2006.

- 7.3.2.21. Toilet discharge system connections [clause 4.2.9.3.]

Specific case for Finland:

Category 'P'- permanent

The connections for emptying and for rinsing and their seals shall comply with figures M VII1 and M VII2 respectively of Annex M VI.

- 7.3.2.22. Water filling adapters [clause 4.2.9.5.]

Specific case for Finland:

Category 'P'- permanent

The water filling adapters shall be as shown in Figure M VII3 of Annex M VII.

- 7.3.2.23. Fire Standards [clause 7.1.6]

Specific Case for Spain

Category 'T' — temporary

Until EN45545-2 is published the Spanish rules on fire standards (DT-PCI/5A) will apply

ANNEXES TO THE TSI

'Rolling stock' Sub-System

ANNEX A	Passive safety — crashworthiness	269
A.1	Detailed description of the static and passive safety requirements	269
A.1.1	Detailed mechanical boundary characteristics for the static resistance	269
A.1.2	Detailed mechanical boundary characteristics for passive safety strength	269
A.1.2.1	Mass definition	269
A.1.2.2	Dynamic Strength	269
A.1.2.3	Assessment criteria	269
A.2	Detailed specification for passive safety	270
A.3	Acceptance criteria	270
A.3.1	Reduce the risk of overriding	270
A.3.2	Limit deceleration	270
A.3.3	Maintain survival space and structural integrity of the passengers occupied areas	270
A.3.4	Protection against a low obstacle	271
A.4	Validation method	271
A.4.1	Process:	271
A.4.2	Test specifications	272
A.4.3	Acceptance criteria for calibration	273
A.5	Obstacle definitions	273
A.5.1	For collisions between a train and a wagon of 80 tons with side buffers:	273
A.5.2	For collisions between a train and a heavy obstacle at level crossing	274
ANNEX B	Anthropometric data and forward visibility for train drivers	275
B.1	General	275
B.2	Anthropometric data for drivers	275
B.3	Signal position in relation to the driver's cab.	276
B.4	Reference positions of driver's eyes	276
ANNEX C	UK1 (issue 2) Gauge	278
C.1	The UK1 (issue 2) profiles	278
C.2	Lower sector UK1[A] profile below 1 100 mm arl	279
C.3	Upper sector UK1[B] profile above 1 100 mm arl	280
C.4	Upper sector UK1[D] profile above 1 100 mm arl	281
C.5	Application of UK1[A] profile	282
C.6	Application of UK1[B] profile	282
C.7	Application of UK1[D] profile	282
C.8	Calculation of width reduction	282
ANNEX D	Assessment of interoperability constituents	284
D.1	Scope	284
D.2	Characteristics	284
ANNEX E	Assessment of the rolling stock subsystem	285
E.1	Scope	285
E.2	Characteristics and modules	285
ANNEX F	Procedures for assessment of conformity and suitability for use	290
F.1	List of the modules	290
F.2	Modules for interoperability constituents	290
F.2.1	Module A: Internal production control	290

F.2.2	Module A1: Internal Design Control with Production Verification	291
F.2.3	Module B: Type Examination	293
F.2.4	Module C: Conformity to Type	296
F.2.5	Module D: Production Quality Management System	296
F.2.6	Module F: Product Verification	299
F.2.7	Module H1: Full Quality Management System	301
F.2.8	Module H2: Full Quality Management System With Design Examination	304
F.2.9	Module V: Type-Validation By In Service Experience (Suitability For Use)	308
F.3	Modules for the ec verification of subsystems	311
F.3.1	Module SB: Type Examination	311
F.3.2	Module SD: Production Quality Management System	313
F.3.3	Module SF: Product Verification	318
F.3.4	Module SH2: Full Quality Management System with Design Examination	321
F.4	Assessment of maintenance arrangements: conformity assessment procedure	327
ANNEX G	Effects of Crosswinds	328
G.1	General remarks	328
G.2	Introduction	328
G.3	General principles	328
G.4	Range of application	328
G.5	Assessment of characteristic wind curves	328
G.5.1	Aerodynamic properties determination	328
G.5.1.1	General remarks	328
G.5.1.2	Wind tunnel test requirements	329
G.5.1.2.1	Test section dimensions	329
G.5.1.2.2	Turbulence level	329
G.5.1.2.3	Boundary layer	329
G.5.1.2.4	Reynolds' number	329
G.5.1.2.5	Instrumentation	329
G.5.1.3	Model requirements	329
G.5.1.4	Test programme requirements	330
G.5.2	Description of the Wind Scenario	331
G.5.3	Calculation of the turbulence characteristics	332
G.5.3.1	Turbulence Intensity	332
G.5.3.2	Gust Duration	332
G.5.3.3	Derivation of the resulting time history of the gust	333
G.5.4	Vehicle dynamics determination	334
G.5.4.1	General remarks	334
G.5.4.2	Modelling	335
G.5.4.3	Verification of the Vehicle Model	335
G.6	Aerodynamic forces and moments as inputs for the multi-body simulation	336
G.7	Calculation and representation of characteristic wind curves	336
G.7.1	Evaluation of the Criterion	336
G.7.2	Calculation of the Wind Values and Limiting Values for $\Delta Q/Q_0$	337
G.7.3	Considering Different Wind Angles	337
G.7.4	Representation of Wind Characteristics by Distinct Points	338

G.7.4.1	Vehicle on straight track	338
G.7.4.2	Vehicle in a curve	338
G.8	Required documentation	338
ANNEX H	Front and rear lamps	339
H.1	Definitions	339
H.2	Front lamps	339
H.3	Rear lamps	341
H.4	Conformity type testing of interoperable constituent	342
ANNEX I	Information required to appear in the 'register of rolling stock'	344
I.1	General information	344
I.2	Section A: Definition of the scope of the register of rolling stock	344
I.3	Section B: Names of parties involved	344
I.4	Section C: Conformity assessment	345
I.5	Section D: Characteristics of the rolling stock	345
I.5.1	Subsection D.1 for the rolling stock subsystem	345
I.5.2	Subsection D.2 for the control-command and signalling subsystem	345
I.5.3	Subsection D.3 for the energy subsystem	346
I.6	Section E: Maintenance data	346
ANNEX J	Windscreen properties	347
J.1	Optical properties	347
J.1.1	Optical Distortion	347
J.1.2	Secondary Images	347
J.1.3	Haze	348
J.1.4	Transmittance	348
J.1.5	Chromaticity	348
J.2	Structural requirements	348
J 2.1	Impacts	348
J.2.2	Spalling	349
ANNEX K	Coupler	350
K.1	Schematic of the coupler	350
K.2	Towing coupler used for recovery and rescue	350
K.2.1	Definition of terms	350
K.2.2	General conditions	351
K.2.2.1	Speeds	351
K.2.2.2	Brakes	351
K.2.2.3	General Pneumatic connection	351
K.2.2.4	Coupling Process	351
K.2.2.5	Uncoupling conditions	351
K.2.3	Towing a train fitted with an automatic coupler by means of a towing coupler	351
K.2.3.1	General conditions	351
K.2.3.2	Coupling conditions	351
K.2.4	Towing a train fitted with a draw hook by means of a towing coupler	352
K.2.4.1	General conditions	352
K.2.4.2	Coupling conditions	353

ANNEX L	Aspects not specified in the High Speed Rolling Stock TSI and for which notification of national rules is required	354
ANNEX M	In service limits of the geometric dimensions of wheels and wheelsets	356
ANNEX M I	Not used	359
ANNEX M II	Not used	359
ANNEX M III	Not used	359
ANNEX M IV	Seals for the toilet discharge system connections	360
ANNEX M V	Inlet connections for water tanks	362
ANNEX M VI	Connections for the toilet discharge system on rolling stock	363
ANNEX N:	Measuring Conditions for Noise	365
N.1	Deviations from en ISO 3095:2005	365
N.1.1	Stationary noise	365
N.1.2	Starting noise	366
N.1.3	Pass-by Noise	366
N.1.4	Reference track for pass-by noise	367
N.2	Characterisation of the dynamic performance of the reference tracks	368
N.2.1	Measurement procedure	368
N.2.2	Measurement system	370
N.2.3	Data processing	371
N.2.4	Test report	372
ANNEX O	Earth Protection of the vehicles' metal parts	373
O.1	Earthing principles	373
O.2	Earthing of the vehicle bodyshell	373
O.3	Earthing of the vehicle parts	373
O.4	Earthing of electric installations	373
O.5	Aerials	374
ANNEX P	Calculation method for decelerations in degraded mode and unfavourable climatic conditions ...	375
P.1	Introduction	375
P.2	Definition of Tests	375
P.2.1	Dynamic tests	375
P.2.1.1	Test conditions	375
P.2.1.2	Dynamic test results	376
P.2.1.3	Dynamic tests for adhesion dependant brakes	376
P.2.2	Rig tests for determining the effects of reduced friction	376
P.3	Deceleration Calculations	377
P.3.1	Determination of braking forces F	377
P.3.2	Evaluation of kw — Reduction coefficient due to degraded adhesion	377
P.3.3	Evaluation of kh — Reduction coefficient due to degraded friction	377
P.3.4	Decelerations calculations	378
ANNEX Q	Signs indicating the box which contains the resetting equipment of the emergency alarm	379
ANNEX R	Specific case-Gauge for Finland	380
R.1	General rules	380
R.2	Lower part of the vehicle	380
R.3	Vehicle parts in proximity of the wheel flanges	380

R.4	Vehicle width	380
R.5	lower step and access doors opening outwards for coaches and multiple units	381
R.6	Pantographs and non-insulated live parts on the roof	381
R.7	Rules and later instructions	381
APPENDIX R.A	382
APPENDIX R.B1	383
APPENDIX R.B2	384
APPENDIX R.B3	385
APPENDIX R.C	386
APPENDIX R.D1	388
APPENDIX R.D2	390
APPENDIX R.E	Pantograph and non-insulated live parts	392

ANNEX A

Passive safety — crashworthiness**A.1. Detailed description of the static and passive safety requirements****A.1.1. Detailed mechanical boundary characteristics for the static resistance**

Detailed mechanical boundary characteristics for the mass and the static resistance are described in standard EN 12663:2000, the longitudinal and vertical static loads for the vehicle bodies corresponding to category P-II as minimum.

Assessment for pressure load shall be done by using a static requirement defined in clause 4.2.6.4 of this TSI.

A.1.2. Detailed mechanical boundary characteristics for passive safety strength**A.1.2.1. Mass definition**

The mass shall include 50 % of the mass of the seated passengers fixed to the carbody floor

A.1.2.2. Dynamic Strength

Four design collision scenarios, which consider all combinations of leading end configuration (straight line, unbraked), shall be applied to certify the passive safety:

— **Scenario 1**

Collision between two identical trains (single units trainset or defined formation) at a relative speed of 36 km/h,

— **Scenario 2**

Collision between a train (single units trainset or defined formation) and a railway vehicle equipped with side buffers at a speed of 36 km/h. The railway vehicle shall be a four-axle freight wagon with a mass of 80 tonnes, as defined in clause A.5.

— **Scenario 3**

Collision at a speed of 110 km/h, on a level crossing, with an obstacle equivalent to a 15 t lorry as defined in clause A.5.

— **Scenario 4**

Collision with a small or low obstacle such as a car or animal, which shall be addressed by defining the characteristics of an obstacle deflector.

A.1.2.3. Assessment criteria

If assessing a locomotive, a power head or a driving coach a defined formation shall be used. For the crashworthy design of a locomotive, a power head or a driving coach, the locomotive, the power head or the driving coach shall be considered as the leading vehicle only.

If assessing a train with different end-vehicles, only identical vehicles shall be considered when calculating scenario 1.

If assessing a coach a defined formation shall be used in which the coach is considered in the position behind the locomotive, the power head or the driving coach.

In all cases the defined formation for which validation is carried out shall be clearly defined.

All vehicles compliant to this TSI and which conform to the following characteristics of the first coach behind the leading vehicle of the defined formation shall be accepted for use in interoperable trains without further certification of the train.

- The mass shall be equal or less than the mass of the first coach behind the leading vehicle of the defined formation.
- The peak force shall be equal or less than the peak force of the first coach behind the leading vehicle of the defined formation.
- The mean force shall be equal or less than the mean force applied to the leading vehicle by the first coach of the defined formation behind this leading vehicle. In order to compare the mean levels according to the deformation stroke, the energy-stroke characteristics shall be used. The energy-stroke curve shall be equal or lower than the one of the reference vehicle.

A.2. Detailed specification for passive safety

Overriding risk shall be reduced at the train extremities and between the vehicles comprising the train.

The forces experienced in the crumple zones shall not result in mean decelerations exceeding the acceptance criteria specified in clause A.3 in passenger seated areas and survival spaces

For all scenarios the occupied areas shall not experience any deformations or intrusion which compromise the design survival space and the structural integrity of the passengers occupied areas.

An obstacle deflector shall be fitted at the leading end of the train to reduce the probability of objects such as cars and large animals causing derailment.

Drivers' cabs at the ends of vehicles shall have a minimum of one door or a gangway allowing access for rescue staff in an emergency.

The acceptance criteria are prescribed in clause A.3 and the Validation Procedure shall be in accordance with clause A.4.

A.3. Acceptance criteria

A.3.1. Reduce the risk of overriding

The acceptance criterion for the overriding limitation are that an additional simulation of scenario 1 demonstrates that under the initial vertical offset conditions of 40 mm no lifting of all wheel sets of any bogie occurs and that survival space and deceleration limit requirements are maintained. These criteria alone are sufficient for the validation of overriding resistance.

A.3.2. Limit deceleration

The acceptance criterion for the mean deceleration is 5 g in the occupied areas. The duration for the mean calculation shall correspond to the time from when the net contact force first exceeds zero to the time when the net contact force reaches zero (for the first time) for all collision-involved vehicles in the train.

A.3.3. Maintain survival space and structural integrity of the passengers occupied areas

The driver's cab shall have a survival space for the driver maintaining a section of a minimum of 0,75m length.

The acceptance criteria for the integrity of the passenger occupied areas shall be to limit any reduction to not more than 1 % over 5 m of the initial length of the carbody (except crumple zones) or that the plastic strain in these protected areas shall be less than 10 %.

If adjacent areas of temporary occupation, as defined in clause 4.2.2.3.2, with a lateral dimension greater than 250 mm, are utilised as crumple zones, any longitudinal clearance shall not be reduced by more than 30 % in that zone.

The following diagram gives examples of areas where longitudinal clearance requirements apply:

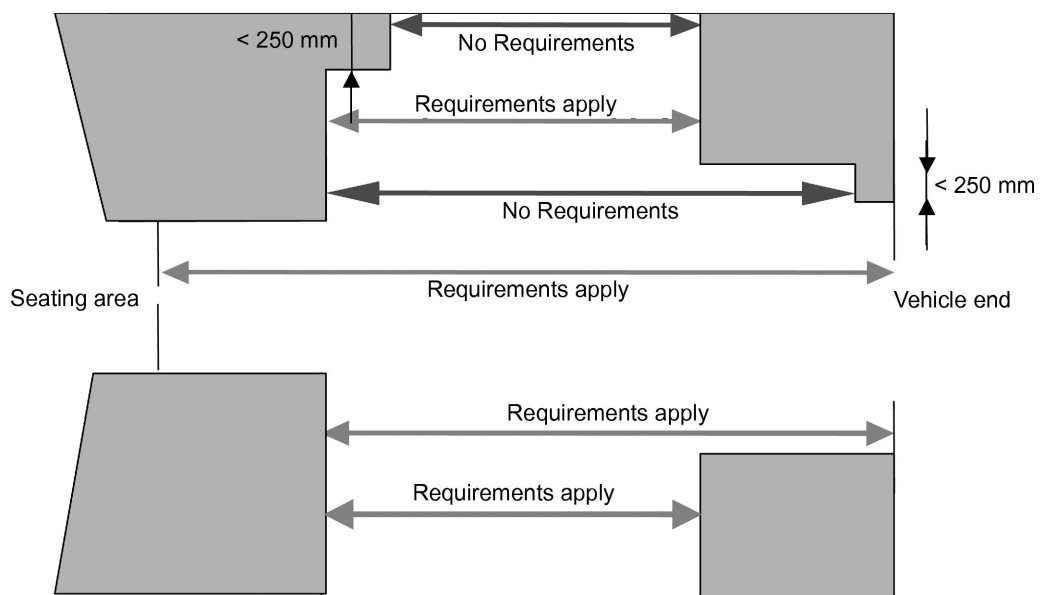

A.3.4. Protection against a low obstacle

An obstacle deflector, with its lower edge as low as the gauge permits, shall be fitted at the leading end of the train and shall be verified by the following longitudinal static requirements, to be met separately:

- 300 kN on the centreline.
- 250 kN at 750 mm from the centreline

The horizontal forces shall be applied over a maximum area of 500 mm by 500 mm. (As permitted by the coupler movement envelope and the maximum corresponding surface of the deflector)

The height of the resultant force shall be not more than 500 mm above rail level.

There shall be no permanent deformation due to these loads. The static resistance of the obstacle deflector shall be compliant with clause 3.4.2 of EN 12663:2000.

A.4. Validation method

A.4.1. Process

The passive safety objectives are given for a complete train. It is impractical to evaluate complete train behaviour by testing therefore the achievement of the objectives shall be validated by dynamic simulation, which correspond to the design collisions scenarios. The use of numerical simulation alone is sufficient for accurate prediction of structural behaviour in areas where the deformation is limited. However, for crumple zones the validation programme shall include the verification of numerical models by appropriate tests (combined method).

The main steps for this combined method for a new design of structure are given below

- Step 1: Test of non-structural absorbing devices and crumple zones:

Dynamic testing on full-size test specimens shall be carried out in order to assure performance of the crash-worthy elements and give inputs for calibration.

The test configuration shall be defined with respect to the following objectives:

- Reflect as close as possible to one of the scenarios

- Make calibration easy
- Utilise the maximum capacity of energy absorption
- Show relevant/particular behaviour of the design
- Step 2: Calibration of the numerical model of the structure:

After carrying out the full size test described in step 1, the manufacturer shall calibrate the numerical model comparing the test results and the corresponding numerical simulation.

The validation of the model shall use two essential phases within the comparison between test and numerical simulation:

- Overall behaviour of the structure, areas where plastic deformations appear, and the sequence of the phenomena of energy absorption,
- Detailed analyses of all test results and more especially of the force levels and displacements of the important points of the structure.
- Step 3: Numerical simulation of the design collision scenarios:

A 3-D model of each vehicle structure that will be subjected to permanent deformation shall be created.

This model shall include the driver's cabin or vehicle end deforming structures, calibrated model from Step 2, and a complete 3D model of the rest of the carbody structure (Normally only the first or the first two vehicles models shall incorporate energy absorbing elements and deforming structure in detail. The remaining vehicles of the train can be represented as lumped mass/spring systems etc. representing their overall behaviour).

If the carbodies are symmetric about the centre line, it is permissible to consider a half-model.

Finally simulations of the whole design collision scenarios shall be carried out in order to have the vehicles approved against the requirements of this TSI. To validate behaviour at the point of impact, the complete train unit model shall contain the validated vehicle models from step 2 with the remaining vehicles in the train unit represented in a simplified form.

It is permissible to use a reduced validation programme if modifications have been made to a previously verified design and if:

- The safety margin against the requirements is sufficient to accommodate any resulting uncertainties; and
- Any modifications do not significantly change the mechanisms providing the passive safety.

However, in this case the crashworthiness performance shall be validated to a level appropriate to the degree of change by:

- A comparison with a similar solution (via engineering drawings or other technical data) or
- A combination of computer simulations/calculations (e.g. FEA or multi-body modelling) and testing (quasi-static or dynamic)

A.4.2. Test specifications

For a dynamic test, the impact speed, the obstacle type, as well as its mass shall be chosen so that the energy absorbed by the test specimen is as a minimum equivalent to 50 % of the maximum energy to be dissipated in scenario 1 or 2 for the sum of all steps used in scenario 1 and 2.

All dedicated absorbers, which are designed to absorb energy in a controlled manner, shall be tested.

It is permissible to perform separate tests that do not include all the energy absorbing elements together, but all energy absorption steps that could interact shall be included in the same test. Elements such as the obstacle deflector, energy absorbing elements and the coupler etc are permitted to be considered in this way.

Similarly, for the individual testing of the inter-vehicle devices (couplers, anti-climbers and the devices for energy absorption), the effective speed and mass, shall be chosen so that the energy absorbed at the interface and the behaviour of elements constituting the interface are equivalent to those observed in these areas during the design collision scenarios.

In accordance with the crashworthiness test specification, the results of measurements: with the appropriate accuracy, carried out during the tests shall contain the following, records necessary for the calibration of the numerical model:

- The measurement of forces, record of the deformations, collision speed, decelerations for performance comparisons (energies, deformations etc) of the various energy absorption devices during this test and during the component tests.
- The dimensional measurements before and after tests in the areas defined and agreed prior to the test.
- Records of the test configuration, general views and detailed drawings using, where necessary, high-speed video allowing comparison of the kinematics of the test with the corresponding simulation.
- The speed of impact and the mass of the vehicle

A.4.3. Acceptance criteria for calibration

The correlation shall be validated using the following criteria:

- Consideration of the sequence of events occurring during the collision (scenarios include several phases of energy absorption).
- The observed deformations during tests corresponding to those found in the analysis.
- Level of energy dissipated by the model (according to the evolution of the total kinetic energy and the speed) with an acceptance of a difference less than 10 %.
- Level of displacements (stroke) of the model with an acceptance of a difference less than 10 %.
- Level of the overall force curve in the model with an acceptance of a difference less than 10 % for the mean values of the overall curve and the parts corresponding to each deformation step.

A.5. Obstacle definitions

A.5.1. For collisions between a train and a wagon of 80 tons with side buffers:

The wagon of 80 tons shall be a unified freight wagon with bogies equipped with side buffers (as defined in The Conventional Rail Freight Wagon TSI) with a stroke of 105 mm. The definition of the obstacle (wagon) is defined in the following Figures:

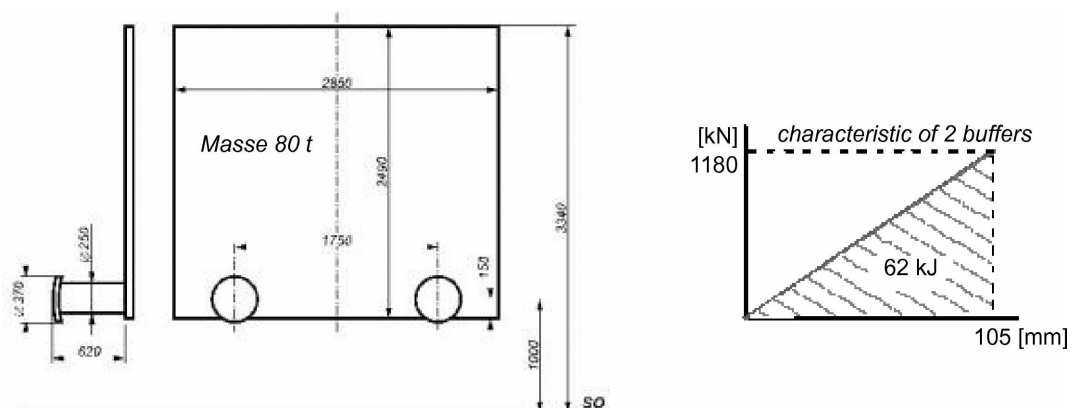

A.5.2. For collisions between a train and a heavy obstacle at level crossing

A deformable equivalent numerical obstacle of 15 000 kg (as defined in the following figures) shall be used. This shall be simulated as a complete numerical model using specific crash software

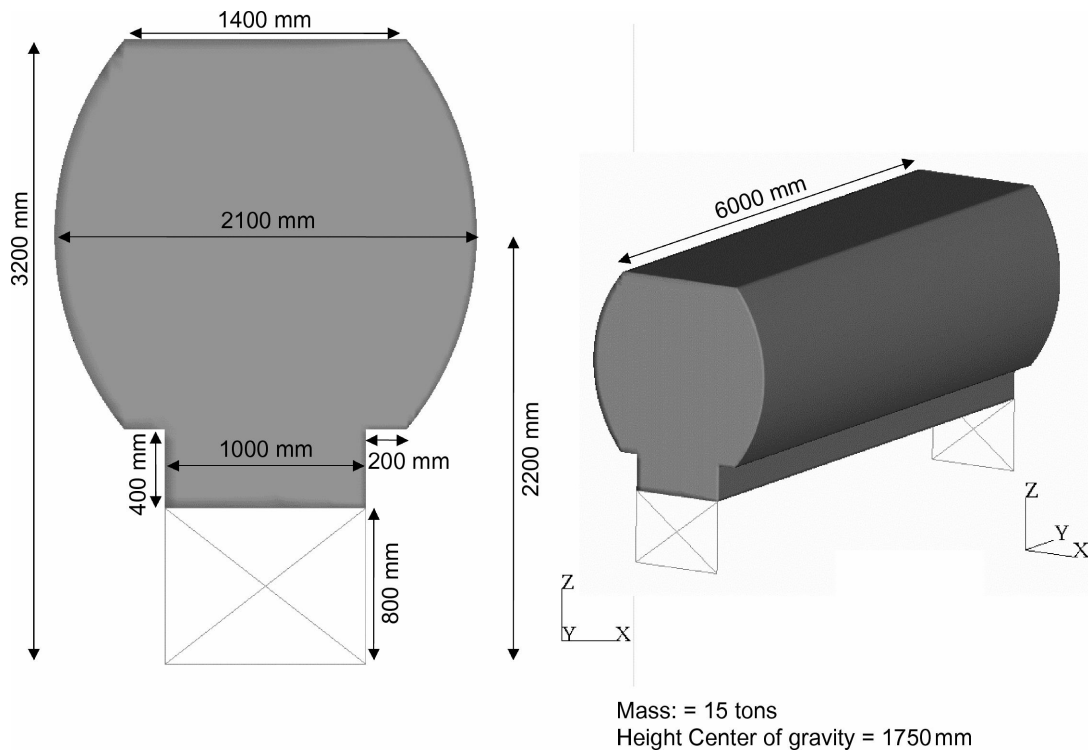

For the definition of the stiffness of the obstacle, the values of the force curve (in function of the displacement) obtained against a sphere of 50 t with a diameter of 3 m at a speed of 30 m/s, shall be higher than the following curve:

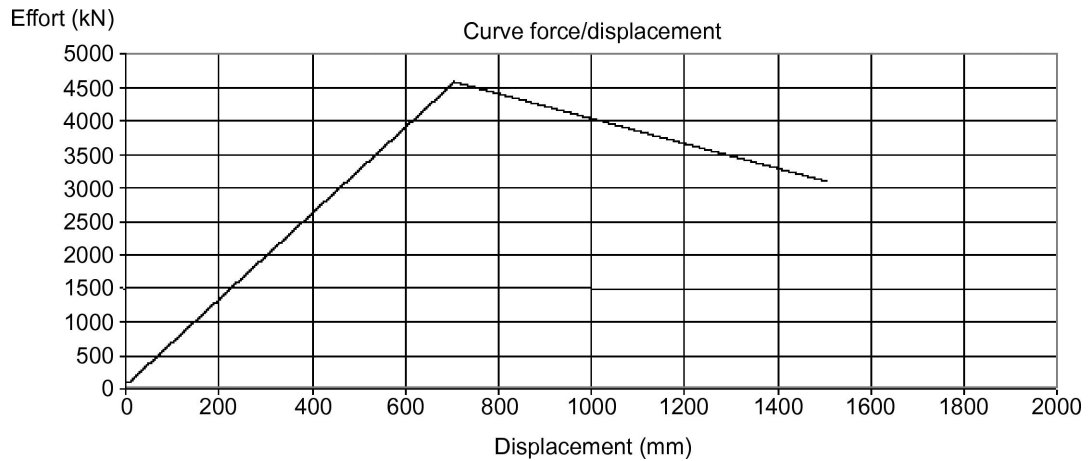

With the following values for the definition of the curve:

Absolute displacement of the sphere (mm)	Contact Force (kN)
0	0
700	4 500
1 500	3 000

ANNEX B

Anthropometric data and forward visibility for train drivers

B.1. General

The dimensions for a driver's eye position are based on a driver's height range described below

B.2. Anthropometric data for drivers

Figure B.1.

Principal anthropometric measurements of the shortest and tallest driving staff

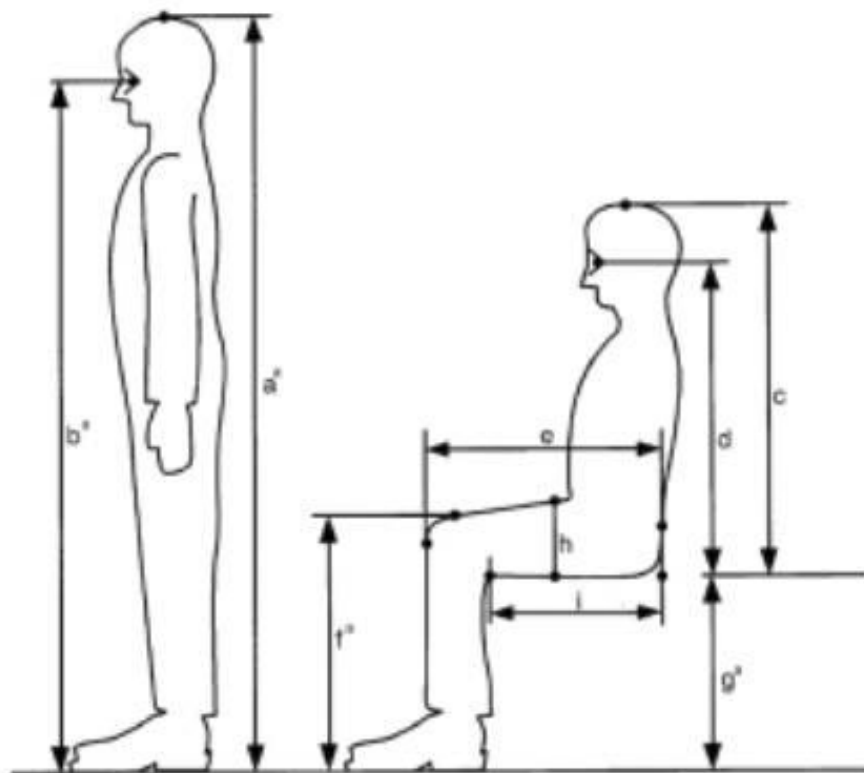

	a	a ^(*)	b ^(*)	c	d	e	f ^(*)	g ^(*)	h	i
MIN	1 600	1 630	1 530	840	740	555	530	425	120	440
MAX	1 900	1 930	1 805	980	855	660	635	505	180	520

(*) Measurement including footwear (30 mm)

B.3. Signal position in relation to the driver's cab.

Figure B.2.

Signal Location

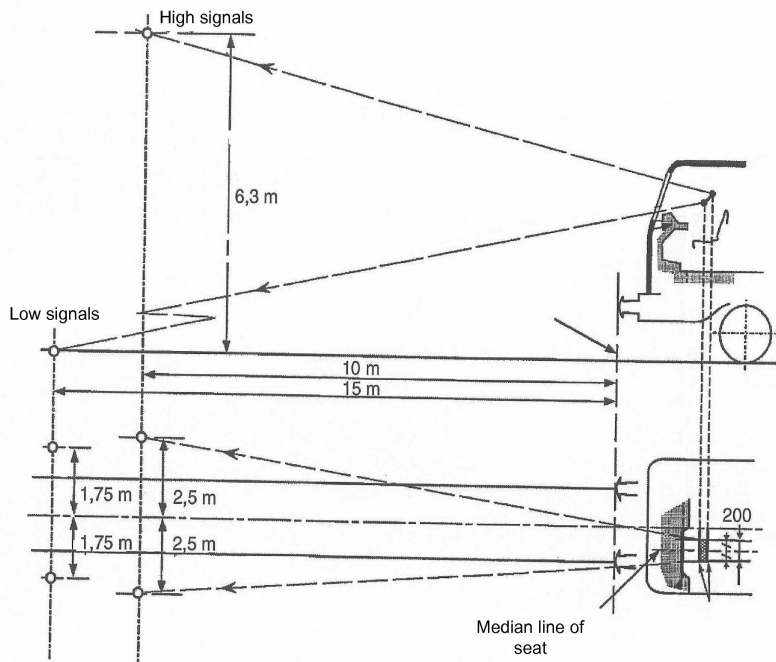

B.4. Reference Positions of Driver's Eyes

Figure B.3.

Desk with Shelf and Rigid Foot Rest

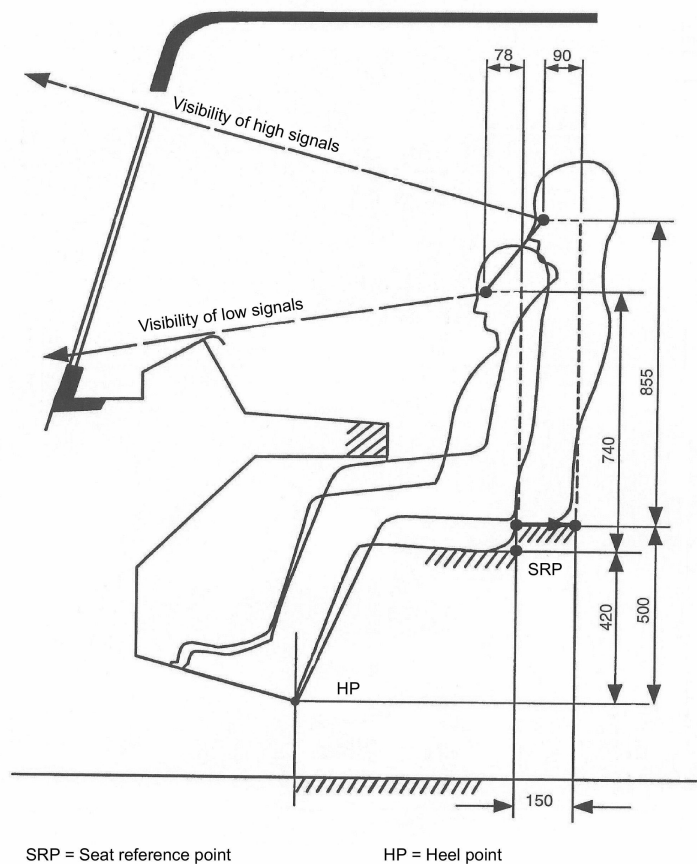

SRP = Seat reference point

HP = Heel point

Figure B.4.

Desk with shelf and adjustable foot rest

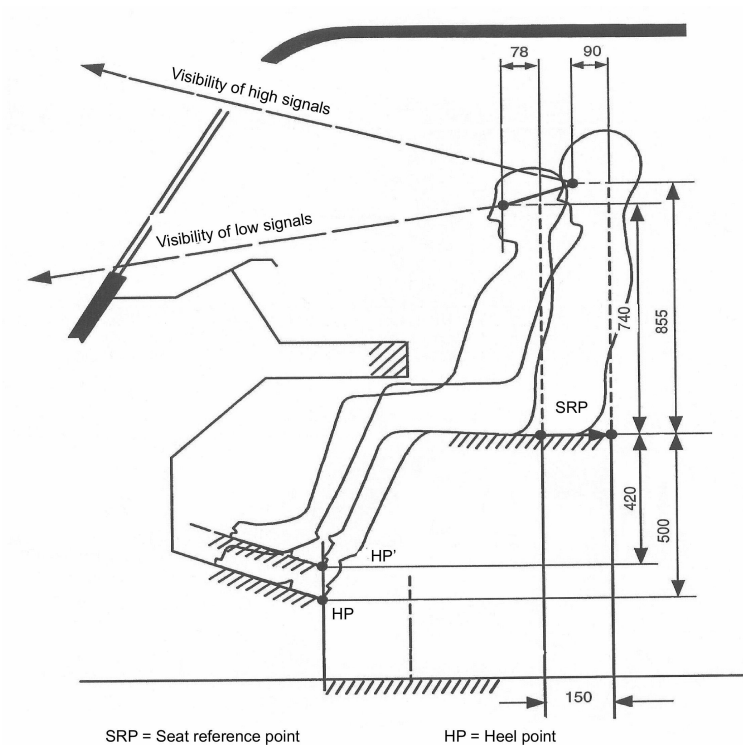
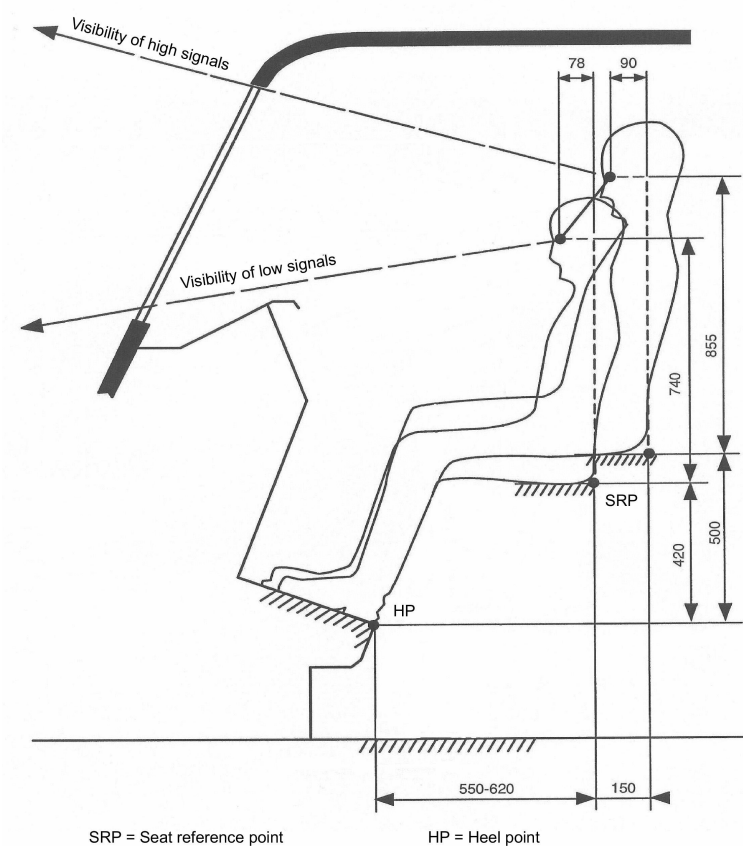

Figure B.5.

Desk without Shelf and Rigid Foot Rest



ANNEX C

UK1 (issue2) Gauge

C.1. The UK1 (Issue 2) profiles

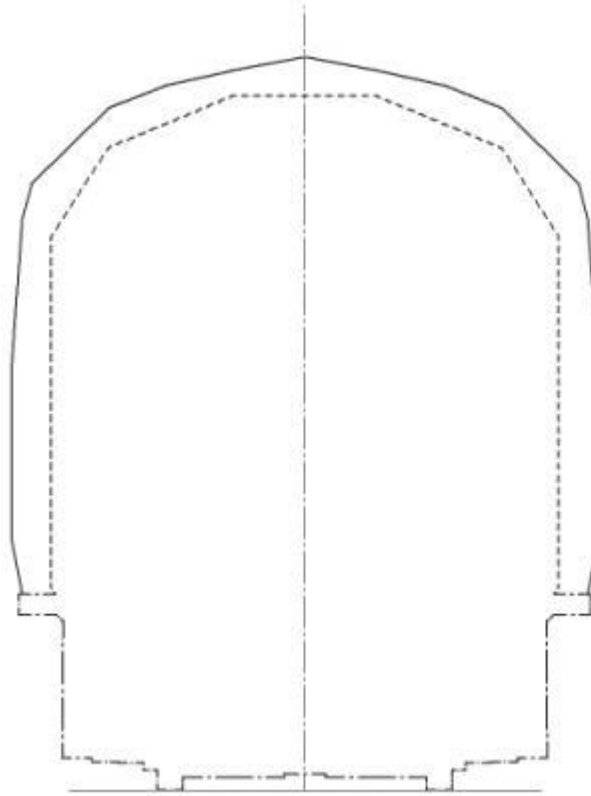

UK1 (issue 2) profiles

UK1 (Issue 2) has been defined using a number of methodologies appropriate to the British railway infrastructure, which allows maximum use of limited space.

The UK1 (Issue 2) gauge consists of 3 profiles, UK1[A], UK1[B], UK1[D].

Under this classification, [A] gauges are vehicle gauges with no reliance on infrastructure parameters, [B] gauges are vehicle gauges that contain limited (specific) vehicle suspension movement, but do not include overthrows, and [D] gauges are templates defining the maximum infrastructure space available on straight and level track.

Below 1 100 mm ARL, a fixed infrastructure gauge is defined in Railway Group Standard GC/RT5212 (Issue 1, February 2003), which provides an optimum limiting position for platforms and equipment designed to be in close proximity to the train. UK1[A] is a complementary vehicle gauge, which includes all necessary tolerances movements and a clearance to the infrastructure.

The vehicle shall not project beyond UK1[A], shown by the dashed profile.

Above 1 100 mm ARL, there are two profiles; the inner being UK1[B] (dotted profile) and the outer being UK1[D] (solid profile).

These profiles define a typical vehicle UK1[B] and the theoretical maximum size of a vehicle, UK1[D] that could be accommodated along the routes for which the gauge has been declared.

UK1[B] is defined according to a typical vehicle configuration that would be able to operate on all routes declared to be UK1 compliant. It should be noted that this vehicle has been designed using simple static gauging rules and would not make optimal use of the Network Rail controlled infrastructure.

UK1[D] defines the minimum static size of the Network Rail controlled infrastructure on the UK1 compliant routes as defined on 1st January 2004. It is not adjusted for track curvature. When applied using an approved methodology, and with the inclusion of clearances and tolerances defined by Railway Group Standard GC/RT5212 (Issue 1, February 2003), this profile defines the maximum available envelope on straight and level track. Additional space could be available locally to accommodate overthrow and dynamic movement related to curvature. As network improvements are implemented, more space than that shown above could become available.

Network data that can be used for vehicle design in accordance with an approved methodology is available from Network Rail Infrastructure Ltd.

UK1[D] can also be used to define a vehicle of any geometric dimensions and suspension configuration. This vehicle would, however, be smaller than UK1[B] since the modelling performed to develop UK1[B] considers the shape of the infrastructure adjusted for vehicle throws. Thus, on sections of curved track, there may be more infrastructure space available than is demonstrated by the UK1[D] profile. This explains why the UK1[B] profile exhibits a different shape to the UK1[D] profile.

In using the infrastructure information for developing vehicle shape, the space between UK1[B] and UK1[D] can be used to accommodate suspension movements, rather than restricting the gauge line.

It is important to note, and understand, the methodologies outlined above in order to develop the largest vehicles suitable for the British infrastructure.

C.2. Lower Sector UK1[A] Profile below 1 100 mm ARL

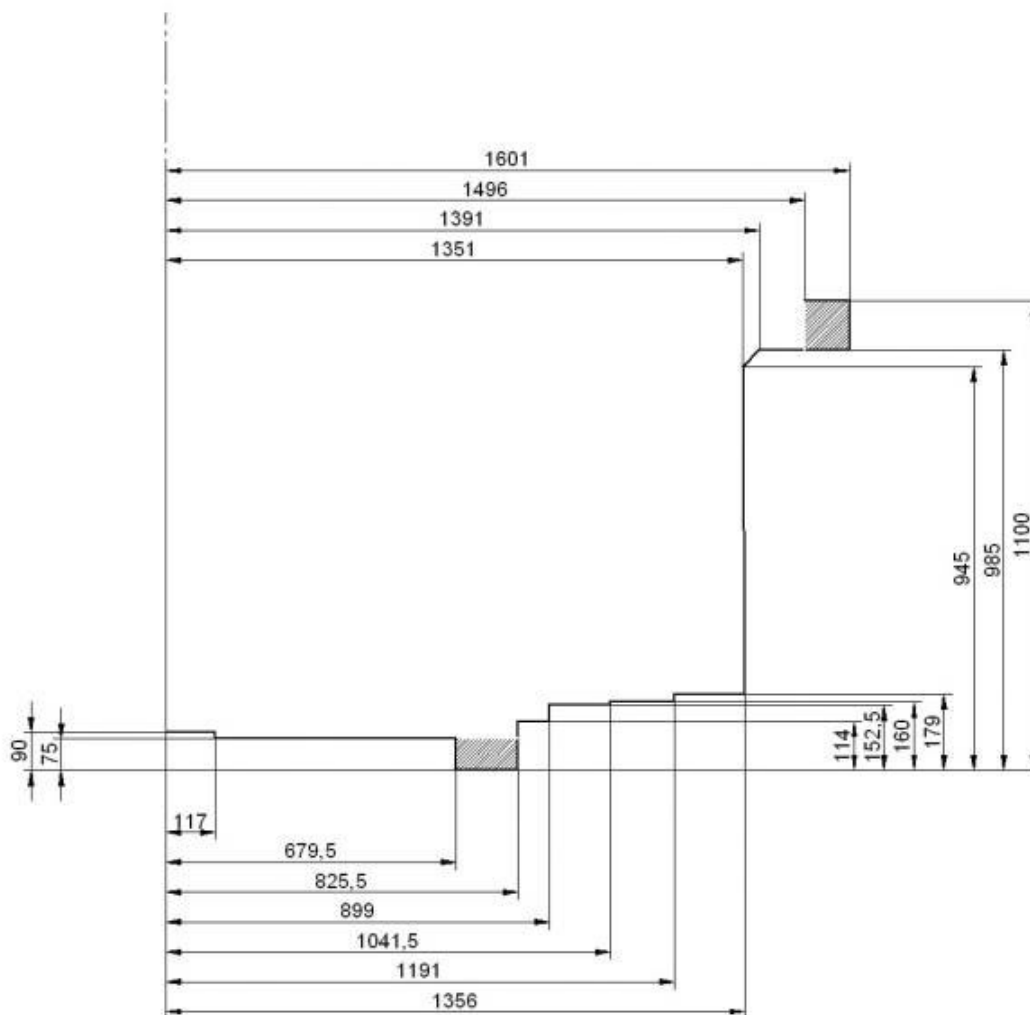

The hatched area bounded by points 17 to 20 is typically used for footsteps.

The hatched area bounded by points 4, 5 and 6 is available for wheels, lifeguards, etc. only.

Coordinates for UK1[A] Profile

Point	X (mm)	Y (mm)
1	0	90
2	117	90
3	117	75
4	679,5	75
5	679,5	0
6	825,5	0
7	825,5	114
8	899	114
9	899	152,5
10	1 041,5	152,5
11	1 041,5	160
12	1 191	160
13	1 191	179
14	1 356	179
15	1 351	945
16	1 391	985
17	1 496	985
18	1 496	1 100
19	1 601	1 100
20	1 601	985

C.3. Upper Sector UK1[B] Profile above 1 100 mm ARL

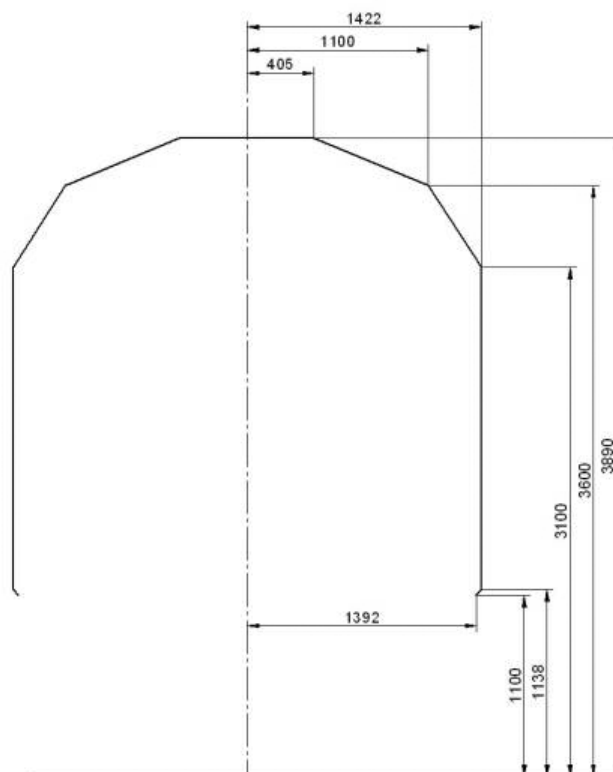

Coordinates for UK1[B] profile

Point	X (mm)	Y (mm)
1	0	3 890
2	405	3 890
3	1 100	3 600
4	1 422	3 100
5	1 422	1 138
6	1 392	1 100

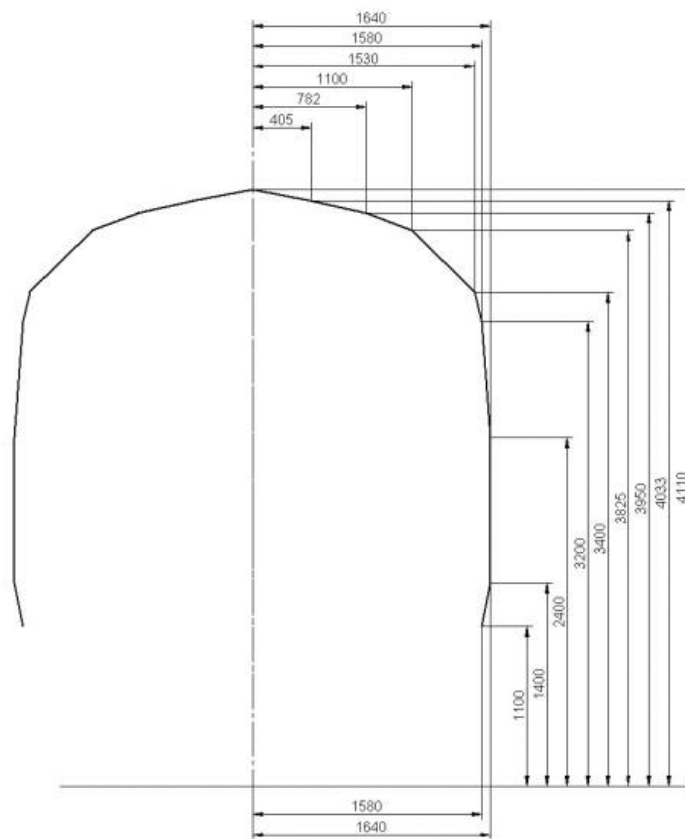
C.4. Upper Sector UK1[D] Profile above 1 100 mm ARL**Coordinates for UK1[D] profile**

Point	X (mm)	Y (mm)
1	0	4 110
2	405	4 033
3	782	3 950
4	1 100	3 825
5	1 530	3 400
6	1 580	3 200
7	1 640	2 400
8	1 640	1 400
9	1 580	1 100

C.5. Application of UK1[A] Profile

The UK1[A] profile shall include all kinematic movements, wear and lateral and vertical throws.

Points 14 to 20 are permitted to be widened laterally on curves of less than 360 m radius according to the following formula:

$$dX = (26\ 000/R) - 72$$

where R is the curve radius in metres and dX is in mm.

Gauge vertical under-clearances shall not be infringed under any condition of loading and wear. Vertical suspension travel shall be considered to be to solid or bump stop condition.

Under the above loading and wear conditions, the vehicle shall not infringe the gauge under-clearance when on a concave or convex vertical curve of 500 m radius. Vertical curve overthrows shall be calculated using the formula for E_i and E_o in section 8 below (using $K = 0$).

C.6. Application of UK1[B] Profile

The 1 100 mm ARL dimension is an absolute minimum.

If the bogie centre distance is less than 17 m, no width reduction needs to be applied.

If the bogie centre distance is greater than 17 m, the lateral dimensions of the profile shall be reduced by the amount calculated using the formulae given in section 8. The values to be used are:

$$R = 200 \text{ m}$$

$$K = 0,181 \text{ m}$$

The UK1[B] profile includes an overall allowance for dynamic movements, vehicle tolerances and some geometric movements of 100 mm. This shall include:

Lateral, Vertical and Roll suspension movements

Tolerances required by the vehicle builder

Geometrical effect of vertical curvature

Where the above effects exceed 100 mm, then an appropriate body dimension reduction shall be applied. Similarly, it is permissible to increase body dimensions if less than 100 mm is required to accommodate these effects.

C.7. Application of UK1[D] Profile

It is permissible for the vehicle to be built to the limits of the infrastructure envelope shown, subject to route assessment using an approved methodology and agreement with the infrastructure manager regarding clearance, tolerances and track fixity regimes appropriate to vehicle operation. Additional space for kinematic movement and curve overthrow could be available beyond the profile described, as described by the route database maintained by the Network Rail Ltd.

C.8. Calculation of Width Reduction

This section sets out the calculation for the gauge line reduction that shall be applied to accommodate the effects of overthrow on curves. The calculations are identical to, but expressed differently from, those given in the High Speed Infrastructure TSI 2006 for calculation of over-throw on curves. The same calculations can be used for calculating vertical reductions.

Where a vehicle is to be built to a vehicle gauge, the lateral dimensions defined by the gauge shall be reduced if the overall length or bogie centres exceed those specified in the gauge. Where reduced vehicle length or bogie centres are used, it is not permissible to increase the vehicle build profile.

In the following calculations, the variables are:

- A = The wheelbase/bogie centres in metres
N_i = The distance of the cross section being calculated from the bogie pivot/axle position (in metres) where this is inside of the wheelbase/bogie centres
N_o = The distance of the cross section being calculated from the bogie pivot/axle position (in metres) where this is outside of the wheelbase/bogie centres
R = The curve radius (in metres) at which the reduction is to be calculated
K = The overthrow allowed at the defined radius (in metres)
E_i = Inside the wheelbase/bogie centre Width Reduction (in metres)
E_o = Outside the wheelbase/bogie centre Width Reduction (in metres)

Formulae:

$$E_i = ((AN_i - N_i^2) / 2R) - K$$

$$E_o = ((AN_o + N_o^2) / 2R) - K$$

Note: E_i and E_o are not permitted to be negative.

ANNEX D

Assessment of interoperability constituents**D.1. Scope**

This annex indicates the assessment of conformity and suitability for use for interoperability constituents within the rolling stock subsystem.

D.2. Characteristics

The characteristics of the interoperability constituents to be assessed in the different phases of design, development and production are marked by X in Table D.1.

Table D.1.

Assessment of Interoperability Constituents of the rolling stock subsystem.

1		2	3	4	5
Interoperability constituents to be assessed		Assessment in the following phase			
		Design and development phase			Production phase
		Design review and/or Design examination	Review of manufacturing process	Type test	Verification of conformity to type
4.2.2.2.2.1	Automatic centre buffer couplers	X	n.a.	X	X
4.2.2.2.2.2	Buffing and draw gear components	X	n.a.	X	X
4.2.2.2.2.3	Towing coupler for recovery and rescue	X	n.a.	X	X
4.2.2.7	Driver's cab windscreen	X	n.a.	X	X
4.2.3.4.9.2	Wheels	X	X	X	X
4.2.7.4.2.5	Horns	X	n.a.	X	X
4.2.8.3.7	Pantographs	X	n.a.	X	X
4.2.8.3.8	Contact strips	X	n.a.	X	X
4.2.9.3.2	Mobile discharge trolleys	X	n.a.	n.a.	X
4.2.9.5.2	Water filling adapters	X	n.a.	n.a.	X
Annex H clause H.2	Head lamps	X	n.a.	X	X
Annex H clause H.2	Marker lamps	X	n.a.	X	X
Annex H clause H.3	Tail lamps	X	n.a.	X	X
Annex M VI	Connections for toilet discharge system	X	n.a.	n.a.	X

ANNEX E

Assessment of the rolling stock subsystem**E.1. SCOPE**

This annex indicates the assessment of conformity of the rolling stock subsystem

E.2. CHARACTERISTICS AND MODULES

The sub-system characteristics to be assessed in the different phases of design, development and production are marked by X in Table E.1. A cross in column 4 of Table E1 indicates that the relevant characteristics shall be verified by testing each single subsystem.

Table E.1.

Assessment of the rolling stock subsystem

1	2	3	4
Characteristics to be assessed	Design and development phase		Production phase
	Design review and/or design examination	Type Test	Routine Test
4.2. Functional and technical specification of the domain			
4.2.1. General			
4.2.1.1b Maximum service speed of trainsets	X	X	n.a.
4.2.2. Structure and mechanical parts			
4.2.2.2. End couplers and coupling arrangement to rescue trains			
4.2.2.2.1. Subsystem requirements	X	X	n.a.
4.2.2.2.2. Interoperability Constituent requirements	EC declaration of conformity and if applicable EC declaration of suitability for use		
4.2.2.3. Strength of vehicle structure			
4.2.2.3.2. Principles (Functional requirements)	X	n.a.	n.a.
4.2.2.3.3a Static resistance	X	X	n.a.
4.2.2.3.3b Collision scenarios (as per Annex A)	X	X	n.a.
4.2.2.4. Access			
4.2.2.4.1. Passenger Step (Pending requirements of PRM TSI)			
4.2.2.4.2. External Access door			
4.2.2.4.2.1. Passenger access doors	X	X	n.a.
4.2.2.4.2.2. Doors for freight use and for use of the train crew	X	X	n.a.
4.2.2.5. Toilets	X	n.a.	n.a.
4.2.2.6. Driver's cab	X	n.a.	n.a.
4.2.2.7. Front of the train	X	X	n.a.
4.2.2.7. Driver's cab windscreens	EC declaration of conformity		
4.2.2.8. Storage facilities for use by staff	X	n.a.	n.a.

1		2	3	4
Characteristics to be assessed		Design and development phase		Production phase
		Design review and/or design examination	Type Test	Routine Test
4.2.2.9.	External steps for use by shunting staff	X	n.a.	n.a.
4.2.3.	Track interaction and gauging			
4.2.3.1.	Kinematic gauge	X	n.a.	n.a.
4.2.3.2.	Static axle load	X	X	X
4.2.3.3.	Rolling stock parameters which influence ground based train monitoring systems			
4.2.3.3.1.	Electrical resistance	X	X	X
4.2.3.3.2.	Axle Bearing Health Monitoring	X	X	n.a.
4.2.3.4.	Rolling stock dynamic behaviour			
4.2.3.4.1.	General	n.a.	X	n.a.
4.2.3.4.2.	Limit values of running safety	X	X	n.a.
4.2.3.4.3.	Track loading limit values	X	X	n.a.
4.2.3.4.4.	Wheel/rail interface	X	n.a.	n.a.
4.2.3.4.5.	Design for vehicle stability	X	X	n.a.
4.2.3.4.6.	Definition of equivalent conicity	X	n.a.	n.a.
4.2.3.4.7.	Design values for wheel profiles	X	n.a.	n.a.
4.2.3.4.8.	In service values of equivalent conicity	Assessment of this clause is the responsibility of the Member State(s) where the rolling stock is operated.		
4.2.3.4.9.	Wheelsets			
4.2.3.4.9.1.	Wheelsets	X	n.a.	n.a.
4.2.3.4.9.2.	Interoperability Constituent Wheels	EC declaration of conformity EC declaration of Suitability for Use		
4.2.3.4.10.	Specific requirements for vehicles with independently rotating wheels	X	X	n.a.
4.2.3.4.11.	Detection of derailments	X	n.a.	n.a.
4.2.3.5.	Maximum train length	X	n.a.	n.a.
4.2.3.6.	Maximum Gradients	X	X	n.a.
4.2.3.7.	Minimum curve radius	X	X	n.a.
4.2.3.8.	Flange lubrication	X	X	n.a.
4.2.3.9.	Suspension coefficient	X	X	n.a.
4.2.3.10.	Sanding	X	X	n.a.
4.2.4.	Braking			
4.2.4.1.	Minimum Braking Performance	X	X	n.a.
4.2.4.2.	Brake wheel/rail adhesion demand limits	X	n.a.	n.a.
4.2.4.3.	Brake system requirements	X	X	n.a.
4.2.4.4.	Service braking performance	X	X	n.a.
4.2.4.5.	Eddy current brakes	X	X	n.a.
4.2.4.6.	Protection of an immobilised train	X	X	n.a.

1		2	3	4
Characteristics to be assessed		Design and development phase		Production phase
		Design review and/or design examination	Type Test	Routine Test
4.2.4.7.	Brake performance on steep gradients	X	X	n.a.
4.2.4.8.	Brake requirements for rescue purposes	X	X	n.a.
4.2.5. Passenger information and communication				
4.2.5.1.	Public address system	X	X	n.a.
4.2.5.2.	Passenger information signs	X	X	n.a.
4.2.5.3.	Passenger alarm	X	X	X
4.2.6. Environmental conditions				
4.2.6.1.	Environmental conditions	X	n.a.	n.a.
4.2.6.2. Train aerodynamic loads in open air				
4.2.6.2.1.	Aerodynamic loads on track workers at the lineside	X	X	n.a.
4.2.6.2.2.	Aerodynamic loads on passengers on a platform	X	X	n.a.
4.2.6.2.3.	Pressure loads in open air	X	X	n.a.
4.2.6.3.	Crosswinds	X	X	n.a.
4.2.6.4.	Maximum Pressure Variations in Tunnels	X	X	n.a.
4.2.6.5. Exterior noise				
4.2.6.5.2.	Limits for stationary noise	X	X	n.a.
4.2.6.5.3.	Limits for starting noise	X	X	n.a.
4.2.6.5.4.	Limits for pass-by noise	X	X	n.a.
4.2.6.6. Exterior Electromagnetic Interference				
4.2.6.6.2.	Electromagnetic interference	X	X	n.a.
4.2.7. System protection				
4.2.7.1. Emergency exits				
4.2.7.1.1.	Passengers' emergency exits	X	n.a.	n.a.
4.2.7.1.2.	Driver's cab emergency exits	X	n.a.	n.a.
4.2.7.2. Fire safety				
4.2.7.2.2.	Measures to prevent fire	X	n.a.	n.a.
4.2.7.3. Measures to detect/control fire				
4.2.7.2.3.1.	Fire detection	X	X	n.a.
4.2.7.2.3.2.	Fire extinguisher	X	n.a.	n.a.
4.2.7.2.3.3.	Fire resistance	X	X	n.a.
4.2.7.2.4.	Additional measures to improve running capability	X	n.a.	n.a.
4.2.7.2.5.	Specific measures for tanks containing flammable liquids	X	n.a.	n.a.
4.2.7.3.	Protection against electric shock	X	X	n.a.
4.2.7.4. External lights & horn				
4.2.7.4.1.	Front and rear lights (Subsystem Requirements)	X	X	n.a.
4.2.7.4.1.1.	Interoperability Constituent: Head lamps	EC declaration of conformity		

1	2	3	4
Characteristics to be assessed	Design and development phase		Production phase
	Design review and/or design examination	Type Test	Routine Test
4.2.7.4.1.2. Interoperability Constituent: Marker lamps	EC declaration of conformity		
4.2.7.4.1.3. Interoperability Constituent: Tail lamps	EC declaration of conformity		
4.2.7.4.2. Horns	X	X	n.a.
4.2.7.4.2.5. Interoperability Constituent requirements (Horns)	EC declaration of conformity		
4.2.7.5. Lifting/rescue procedures	X	n.a.	n.a.
4.2.7.6. Interior noise	X	X	n.a.
4.2.7.7. Air conditioning	X	X	n.a.
4.2.7.8. Driver's vigilance device	X	X	X
4.2.7.9. Control-command and signalling system			
4.2.7.9.2. Wheelset location	X	X	n.a.
4.2.7.9.3. Wheels	X	X	n.a.
4.2.7.10. Monitoring and diagnostic concepts	X	X	n.a.
4.2.7.11. Particular specification for tunnels	X	n.a.	n.a.
4.2.7.12. Emergency lighting system	X	X	n.a.
4.2.7.13. Software	X	X	n.a.
4.2.8. Traction and electrical equipment			
4.2.8.1. Traction performance requirements	X	X	n.a.
4.2.8.2. Traction wheel/rail adhesion requirements	X	n.a.	n.a.
4.2.8.3. Functional and technical specification related to power supply			
4.2.8.3.1. Voltage and frequency of the electricity supply ⁽¹⁾	X	X	n.a.
4.2.8.3.2. Max. power and maximum current that is permissible to draw from the catenary	X	X	n.a.
4.2.8.3.3. Power factor	X	X	n.a.
4.2.8.3.4. System energy disturbances	X	n.a.	n.a.
4.2.8.3.5. Energy consumption measuring devices	X	n.a.	n.a.
4.2.8.3.6. Rolling stock requirements linked to pantographs	X	X	n.a.
4.2.8.3.7. Interoperability constituent pantograph	EC declaration of conformity		
4.2.8.3.8. Interoperability constituent contact strip	EC declaration of conformity		
4.2.8.3.9. Interfaces with electrification system	X	X	n.a.
4.2.8.3.10. Interfaces with Control- Command and Signalling Subsystem	X	X	n.a.
4.2.9. Servicing			
4.2.9.2. Train external cleaning facilities	X	n.a.	n.a.
4.2.9.3. Toilet discharge system			
4.2.9.3.1. On board discharge system	X	n.a.	n.a.

1	2	3	4
Characteristics to be assessed	Design and development phase		Production phase
	Design review and/or design examination	Type Test	Routine Test
4.2.9.3.1. Connections for toilet discharge system	EC declaration of conformity		
4.2.9.3.2. Mobile discharge trolleys	EC declaration of conformity		
4.2.9.4. Train interior cleaning			
4.2.9.4.1. General	X	n.a.	n.a.
4.2.9.4.2. Electrical Sockets	X	n.a.	n.a.
4.2.9.5. Water restocking equipment			
4.2.9.5.1. General	X	n.a.	n.a.
4.2.9.5.2. Water filling adapter	EC declaration of conformity		
4.2.9.6. Sand restocking equipment	X	n.a.	n.a.
4.2.9.7. Special requirements for stabling of trains	X	n.a.	n.a.
4.2.10. Maintenance			
4.2.10.1. Responsibilities	X	n.a.	n.a.
4.2.10.2. The maintenance file			
4.2.10.2.1. The maintenance design justification file	X	n.a.	n.a.
4.2.10.2.2. The maintenance documentation	X	n.a.	n.a.
4.2.10.3. Management of the maintenance file	X	n.a.	n.a.
4.2.10.4. Management of maintenance information	X	n.a.	n.a.
4.2.10.5. Implementation of the maintenance	X	n.a.	n.a.

(¹) Type Test required at nominal frequency only

ANNEX F

Procedures for assessment of conformity and suitability for use**F.1. List of the modules****Modules for Interoperability Constituents:**

- Module A: Internal production control
- Module A1: Internal design control with product verification
- Module B: Type examination
- Module C: Conformity to type
- Module D: Production quality management system
- Module F: Product verification
- Module H1: Full quality management system
- Module H2: Full quality management system with design examination
- Module V: Type validation by in service experience (Suitability for use)

Modules for Subsystems

- Module SB: Type examination
- Module SD: Product quality management system
- Module SF: Product verification
- Module SH2: Full quality management system with design examination

Module for Maintenance Arrangements

- Module Conformity Assessment Procedure

F.2. Modules for Interoperability Constituents**F.2.1. Module A: Internal production control**

1. This module describes the procedure whereby the manufacturer or his authorised representative established within the Community, who carries out the obligations laid down in point 2, ensures and declares that the interoperability constituent concerned satisfies the requirements of the TSI that apply to it.
2. The manufacturer shall establish the technical documentation described in point 3.
3. The technical documentation shall enable the conformity of the interoperability constituent with the requirements of the TSI to be assessed. It shall, as far as relevant for such assessment, cover the design, manufacture, maintenance and operation of the interoperability constituent. So far as relevant for the assessment, the documentation shall contain:
 - a general description of the interoperability constituent
 - conceptual design and manufacturing information, for example drawings and schemes of components, sub-assemblies, circuits, etc.

- descriptions and explanations necessary for the understanding of the design and manufacturing information, maintenance and the operation of the interoperability constituent
 - the technical specifications including European specifications ⁽¹⁾ with relevant clauses, applied in full or in part,
 - description of the solutions adopted to meet the requirements of the TSI, where the European specifications have not been applied in full,
 - results of design calculations made, examinations carried out, etc,
 - test reports.
4. The manufacturer shall take all the measures necessary in order that the manufacturing process ensures compliance of each manufactured interoperability constituent with the technical documentation referenced in point 3 and with the requirements of the TSI that apply to it.
5. The manufacturer or his authorised representative established within the Community shall draw up a written declaration of conformity for the interoperability constituent. The content of this declaration has to include at least the information indicated in Annex IV (3) and in Article 13-3 of Directives 2001/16/EC. The EC declaration of conformity and the accompanying documents shall be dated and signed.

The declaration shall be written in the same language as the technical documentation and shall contain the following:

- the Directive references (Directives 2001/16/EC and other directives to which the interoperability constituent may be subject),
 - the name and address of the manufacturer or his authorised representative established within the Community (give trade name and full address and in the case of an authorised representative also give the trade name of the manufacturer or constructor),
 - description of interoperability constituent (make, type etc.)
 - description of the procedure (module) followed in order to declare conformity,
 - all the relevant descriptions met by the interoperability constituent and in particular its conditions of use,
 - reference to this TSI and to any other applicable TSI, and where appropriate reference to European specifications,
 - identification of the signatory empowered to enter into commitments on behalf of the manufacturer or of his authorised representative established within the Community.
6. The manufacturer or his authorised representative shall keep a copy of the EC declaration of conformity with the technical documentation for a period of 10 years after the last interoperability constituent has been manufactured.

Where neither the manufacturer nor his authorised representative is established within the Community, the obligation to keep the technical documentation available is the responsibility of the person who places the interoperability constituent in the Community market.

7. If additional to the EC declaration of conformity, an EC declaration for suitability for use for the interoperability constituent is required by the TSI, this declaration has to be added after being issued by the manufacturer under the conditions of module V.

F.2.2. Module A1: Internal Design Control with Production Verification

1. This module describes the procedure whereby the manufacturer or his authorised representative established within the Community, who carries out the obligations laid down in point 2, ensures and declares that the interoperability constituent concerned satisfies the requirements of the TSI that apply to it.
2. The manufacturer shall establish the technical documentation described in point 3.

⁽¹⁾ The definition of an European specification is indicated in the directives 96/48/EC and 2001/16/EC. The guide for application of HS TSIs explains the way to use the European Specifications

3. The technical documentation shall enable the conformity of the interoperability constituent with the requirements of the TSI to be assessed.

The technical documentation shall also give evidence that the design of the interoperability constituent, already accepted before the implementation of the present TSI, is in accordance with the TSI and that the interoperability constituent has been used in service in the same area of use.

It shall, as far as relevant for such assessment, cover the design, manufacture, maintenance and operation of the interoperability constituent. So far as relevant for the assessment, the documentation shall contain:

- a general description of the interoperability constituent and its conditions of use,
 - conceptual design and manufacturing information, for example drawings and schemes of components, subassemblies, circuits, etc.
 - descriptions and explanations necessary for the understanding of the design and manufacturing information, maintenance and the operation of the interoperability constituent,
 - the technical specifications including European specifications ⁽¹⁾ with relevant clauses, applied in full or in part,
 - descriptions of the solutions adopted to meet the requirements of the TSI, where the European specifications have not been applied in full,
 - results of design calculations made, examinations carried out, etc,
 - test reports,
4. The manufacturer shall take all the measures necessary in order that the manufacturing process ensures compliance of each manufactured interoperability constituent with the technical documentation referenced in point 3 and with the requirements of the TSI that apply to it.
5. The notified body, chosen by the manufacturer, shall carry out the appropriate examinations and tests in order to verify the conformity of the manufactured interoperability constituents with the type described in the technical documentation referenced in point 3 and with the requirement of the TSI. The manufacturer ⁽²⁾ can choose one of the following procedures:

5.1. Verification by examination and testing of every product

- 5.1.1. Each product shall be individually examined and appropriate tests shall be carried out in order to verify the product conformity with the type described in the technical documentation and the requirements of the TSI that apply to it. When a test is not set out in the TSI (or in an European Standard quoted in the TSI), the relevant European Specifications or equivalent tests are applicable
- 5.1.2. The notified body shall draw up a written certificate of conformity for the approved products relating to the tests carried out.

5.2. Statistical verification

- 5.2.1. The manufacturer shall present his products in the form of homogeneous lots and shall take all measures necessary in order that the manufacturing process ensures the homogeneity of each lot produced.
- 5.2.2. All interoperability constituents shall be available for verification in the form of homogeneous lots. A random sample shall be drawn from each lot. Each interoperability constituents in a sample shall be individually examined and appropriate tests shall be carried out to ensure the product conformity with the type described in the technical documentation and the requirements of the TSI that apply to it and to determine whether the lot is accepted or rejected. When a test is not set out in the TSI (or in an European Standard quoted in the TSI), the relevant European Specifications or equivalent tests are applicable

⁽¹⁾ The definition of an European specification is indicated in the directives 96/48/EC and 2001/16/EC. The guide for application of HS TSIs explains the way to use the European Specifications

⁽²⁾ When necessary, the manufacturer's discretion may be limited for specific constituents. In this case, the relevant verification process required for the interoperability constituent is specified in the TSI (or in its annexes)

- 5.2.3. The statistical procedure shall use appropriate elements (statistical method, sampling plan etc), depending on the characteristics to be assessed, as specified in the TSI.
- 5.2.4. In the case of accepted lots, the notified body shall draw up a written certificate of conformity relating to the tests carried out. All interoperability constituents in the lot may be placed on the market except those interoperability constituents from the sample, which were found not to be in conformity.
- 5.2.5. If a lot is rejected, the notified body or the competent authority shall take appropriate measures to prevent placing that lot on the market. In the event of frequent rejection of lots the notified body shall suspend the statistical verification.
6. The manufacturer or his authorised representative established within the Community shall draw up the EC declaration of conformity of the interoperability constituent.

The content of this declaration shall include at least the information indicated in Annex IV (3) and in Article 13-3 of Directive 2001/16/EC. The EC declaration of conformity and the accompanying documents shall be dated and signed.

The declaration shall be written in the same language as the technical documentation and shall contain the following:

- the Directive references (Directives 2001/16/EC and other directives to which the interoperability constituent may be subject),
- the name and address of the manufacturer or his authorised representative established within the Community (give trade name and full address and in the case of an authorised representative also give the trade name of the manufacturer or constructor),
- description of interoperability constituent (make, type, etc)
- description of the procedure (module) followed in order to declare conformity,
- all of the relevant descriptions met by the interoperability constituent and in particular any conditions of use,
- name and address of notified body (bodies) involved in the procedure followed in respect of conformity and date of certificates together with the duration and conditions of validity of the certificates,
- reference to the TSI and any other applicable TSI and where appropriate reference to European specifications,
- identification of the signatory empowered to enter into commitments on behalf of the manufacturer or of his authorised representative established within the Community.

The certificate to be referred to is the certificate of conformity as mentioned in point 5. The manufacturer or his authorised representative established within the Community shall ensure that he is able to supply the notified body's certificates of conformity on request

7. The manufacturer or his authorised representative shall keep a copy of the EC declaration of conformity with the technical documentation for a period of 10 years after the last interoperability constituent has been manufactured.

Where neither the manufacturer nor his authorised representative is established within the Community, the obligation to keep the technical documentation available is the responsibility of the person who places the interoperability constituent in the Community market.

8. If additional to the EC declaration of conformity, an EC declaration for suitability for use for the interoperability constituent is required by the TSI, this declaration has to be added after being issued by the manufacturer under the conditions of module V.

F.2.3. Module B: Type Examination

1. This module describes that part of the procedure by which a notified body ascertains and attests that a type, representative of the production envisaged, meets the provisions of the TSI that apply to it.

2. The application for the EC type-examination shall be lodged by the manufacturer or his authorised representative established within the Community.

The application shall include:

- the name and address of the manufacturer and also, if the application is lodged by the authorised representative, his name and address,
- a written declaration that the same application has not been lodged with any other notified body,
- the technical documentation, as described in point 3.

The applicant shall place at the disposal of the notified body a specimen, representative of the production envisaged and hereinafter called 'type'.

A type may cover several versions of the Interoperability Constituent provided that the differences between the versions do not affect the provisions of the TSI.

The notified body may request further specimens if needed for carrying out the test programme.

If no type tests are requested within the type examination procedure, and the type is sufficiently defined by the technical documentation, as described in point 3, the notified body shall agree that no specimens are placed at its disposal.

3. The technical documentation shall enable the conformity of the interoperability constituent with the requirements of the TSI to be assessed. It shall, as far as relevant for such assessment, cover the design, manufacture, maintenance and operation of the interoperability constituent.

The technical documentation shall contain:

- a general type-description,
- conceptual design and manufacturing information, for example drawings, schemes of components, sub-assemblies, circuits, etc.,
- descriptions and explanations necessary for the understanding of the design and manufacturing information, maintenance and the operation of the interoperability constituent,
- conditions of integration of the interoperability constituent in its system environment (sub-assembly, assembly, subsystem) and the necessary interface conditions,
- conditions for use and maintenance of the interoperability constituent (restrictions of running time or distance, wear limits etc),
- the technical specifications, including European specifications ⁽¹⁾ with relevant clauses, applied in full or in part,
- description of the solutions adopted to meet the requirements of the TSI in cases where the European specifications have not been applied in full,
- results of design calculations made, examinations carried out, etc.,
- test reports,

4. The notified body shall:

- 4.1. examine the technical documentation,
- 4.2. verify that any specimen(s) required for tests has (have) been manufactured in conformity with the technical documentation, and carry out or have carried out the type tests in accordance with the provisions of the TSI and/or the relevant European specifications,

⁽¹⁾ The definition of an European specification is indicated in the directives 96/48/EC and 2001/16/EC. The guide for application of HS TSIs explains the way to use the European Specifications

- 4.3. where a design review is requested in the TSI, perform an examination of the design methods, the design tools and the design results to evaluate their capability to fulfil the requirements for conformity for the interoperability constituent at the completion of the design process,
 - 4.4. where a review of the manufacturing process is requested in the TSI, perform an examination of the manufacturing process devised for manufacturing the interoperability constituent, to evaluate its contribution to product conformity, and/or examine the review carried out by the manufacturer at the completion of the design process,
 - 4.5. identify the elements, which have been designed in accordance with the relevant provisions of the TSI and the European specifications, as well as the elements, which have been designed without applying the relevant provisions of those European Specifications;
 - 4.6. perform or have performed the appropriate examinations and necessary tests in accordance with points 4.2., 4.3. and 4.4. to establish whether, where the manufacturer has chosen to apply the relevant European specifications, these have actually been applied;
 - 4.7. perform or have performed the appropriate examinations and necessary tests in accordance with points 4.2., 4.3. and 4.4. to establish whether, where the relevant European specifications have not been applied, the solutions adopted by the manufacturer meet the requirements of the TSI;
 - 4.8. agree with the applicant the location where the examinations and necessary tests will be carried out.
5. Where the type meets the provisions of the TSI, the notified body shall issue a type-examination certificate to the applicant. The certificate shall contain the name and address of the manufacturer, conclusions of the examination, conditions for its validity and the necessary data for identification of the approved type.

The time period of validity shall be no longer than 5 years.

A list of the relevant parts of the technical documentation shall be annexed to the certificate and a copy kept by the notified body.

If the manufacturer or his authorised representative established within the Community is denied a type-examination certificate, the notified body shall provide detailed reasons for such denial.

Provision shall be made for an appeals procedure.

6. The applicant shall inform the notified body that holds the technical documentation concerning the type-examination certificate of all modifications to the approved product which may affect the conformity with the requirements of the TSI or the prescribed conditions for use of the product. In such cases the interoperability constituent shall receive additional approval from the notified body that issued the EC type examination certificate. In this case, the notified body shall perform only those examinations and tests that are relevant and necessary to the changes. The additional approval shall be given either in the form of an addition to the original type-examination certificate, or, by the issue of a new certificate after withdrawal of the old one.
7. If no modifications as in point 6 have been made, the validity of an expiring certificate can be extended for another period of validity. The applicant will apply for such a prolongation by a written confirmation that no such modifications have been made, and the notified body issues a prolongation for another period of validity as in point 5, if no contrary information exists. This procedure can be reiterated.
8. Each notified body shall communicate to the other notified bodies the relevant information concerning the type-examination certificates and additions issued, withdrawn or refused.
9. The other notified bodies shall receive, on request, copies of the type-examination certificates issued and/or their additions. The annexes to the certificates (see § 5) shall be kept at the disposal of the other notified bodies.
10. The manufacturer or his authorised representative established within the Community shall keep with the technical documentation copies of type-examination certificates and their additions for a period of 10 years after the last interoperability constituent has been manufactured. Where neither the manufacturer nor his authorised representative is established within the Community, the obligation to keep the technical documentation available is the responsibility of the person who places the interoperability constituent on the Community market.

F.2.4. Module C: Conformity to Type

1. This module describes that part of the procedure whereby the manufacturer or his authorised representative established within the Community ensures and declares that the interoperability constituent concerned is in conformity with the type as described in the type-examination certificate and satisfies the requirements of the TSI that apply to it.
2. The manufacturer shall take all measures necessary to ensure that the manufacturing process ensures compliance of each manufactured interoperability constituent with the type as described in the EC type examination certificate and with the requirements of the TSI that apply to it.
3. The manufacturer or his authorised representative established within the Community shall draw up an EC declaration of conformity for the interoperability constituent.

The content of this declaration has to include at least the information indicated in Annex IV (3) and in Article 13-3 of Directive 2001/16/EC. The EC declaration of conformity and the accompanying documents shall be dated and signed.

The declaration shall be written in the same language as the technical documentation and shall contain the following:

- the Directive references (Directive 2001/16/EC and other directives to which the interoperability constituent may be subject),
- the name and address of the manufacturer or his authorised representative established within the Community (give trade name and full address and in the case of an authorised representative also give the trade name of the manufacturer or constructor),
- description of interoperability constituent (make, type etc.)
- description of the procedure (module) followed in order to declare conformity,
- all the relevant descriptions met by the interoperability constituent and in particular its conditions of use,
- name and address of notified body (bodies) involved in the procedure followed in respect of type examination conformity and date of the EC type examination certificate (and its additions) together with the duration and conditions of validity of the certificate,
- reference to the TSI and to any other applicable TSI, and where appropriate reference to European specifications ⁽¹⁾,
- identification of the signatory empowered to enter into commitments on behalf of the manufacturer or of his authorised representative established within the Community.
- The manufacturer or his authorised representative established within the Community shall keep a copy of the EC declaration of conformity for a period of 10 years after the last interoperability constituent has been manufactured.
- Where neither the manufacturer nor his authorised representative is established within the Community, the obligation to keep the technical documentation available is the responsibility of the person who places the interoperability constituent on the Community market.
- If additional to the EC declaration of conformity an EC declaration of suitability for use for the interoperability constituent is required by the TSI, this declaration has to be added after being issued by the manufacturer under the conditions of module V.

F.2.5. Module D: Production Quality Management System

1. This module describes the procedure whereby the manufacturer or his authorised representative established within the Community who satisfies the obligations of point 2 ensures and declares that the interoperability constituent concerned is in conformity with the type as described in the type-examination certificate and satisfies the requirements of the TSI that apply to it.

⁽¹⁾ The definition of an European specification is indicated in the directives 96/48/EC and 2001/16/EC. The guide for application of HS TSIs explains the way to use the European Specifications

2. The manufacturer shall operate an approved quality management system for production, final product inspection and testing as specified in point 3 and is subject to monitoring as specified in point. 4.
3. Quality management system
- 3.1. The manufacturer shall lodge an application for assessment of his quality management system with a notified body of his choice, for the interoperability constituents concerned.

The application shall include:

- all relevant information for the product category representative for the interoperability constituents envisaged,
 - the documentation concerning the quality management system,
 - the technical documentation of the approved type and a copy of the type-examination certificate, issued after the completion of the type examination procedure of module B.
 - a written declaration that the same application has not been lodged with any other notified body,
- 3.2. The quality management system shall ensure compliance of the interoperability constituents with the type as described in the type-examination certificate and with the requirements of the TSI that apply to them. All the elements, requirements and provisions adopted by the manufacturer shall be documented in a systematic and orderly manner in the form of written policies, procedures and instructions. The quality management system documentation shall permit a consistent interpretation of the quality programmes, plan, manuals and records.

It shall contain in particular an adequate description of:

- the quality objectives and the organisational structure,
 - responsibilities and powers of the management with regard to product quality,
 - the manufacturing, quality control and quality management techniques, processes and systematic actions that will be used,
 - the examinations, checks and tests that will be carried out before, during and after manufacture, and the frequency with which they will be undertaken,
 - the quality records, such as inspection reports and test data, calibration data, qualification reports of the personnel concerned, etc.,
 - the means to monitor the achievement of the required product quality and the effective operation of the quality management system.
- 3.3. The notified body assesses the quality management system to determine whether it satisfies the requirements of point 3.2. It presumes compliance with these requirements if the manufacturer implements a quality system for production, final product inspection and testing in respect of the Standard EN/ISO 9001-2000, which take into consideration the specificity of the interoperability constituent for which it is implemented.

When the manufacturer operates a certified quality management system, the notified body shall take this into account in the assessment.

The audit shall be specific for the product category, which is representative for the interoperability constituent. The auditing team shall have at least one member experienced as an assessor in the product technology concerned. The evaluation procedure shall include an inspection visit to the manufacturer's premises.

The decision shall be notified to the manufacturer. The notification shall contain the conclusions of the examination and the reasoned assessment decision.

- 3.4. The manufacturer shall undertake to fulfil the obligations arising out of the quality management system as approved and to uphold it so that it remains adequate and efficient.

The manufacturer or his authorised representative established within the Community shall keep the notified body that has approved the quality management system informed of any intended updating of the quality management system.

The notified body shall evaluate the modifications proposed and decide whether the amended quality management system will still satisfy the requirements of point 3.2 or whether a re-assessment is required.

It shall notify its decision to the manufacturer. The notification shall contain the conclusions of the examination and the reasoned assessment decision.

4. Surveillance of the quality management system under the responsibility of the notified body.
 - 4.1. The purpose of surveillance is to make sure that the manufacturer duly fulfils the obligations arising out of the approved quality management system.
 - 4.2. The manufacturer shall allow the notified body entrance for inspection purposes to the locations of manufacture, inspection and testing, and storage and shall provide it with all necessary information, in particular:
 - the quality management system documentation,
 - the quality records such as inspection reports and tests data, calibration data, qualification reports of the personnel concerned, etc.
 - 4.3. The notified body shall periodically carry out audits to make sure that the manufacturer maintains and applies the quality management system and shall provide an audit report to the manufacturer.

The frequency of the audits shall be at least once a year.

When the manufacturer operate a certified quality management system, the notified body shall take this into account in the surveillance.

- 4.4. Additionally the notified body may pay unexpected visits to the manufacturer. During such visits the notified body may carry out, or cause to be carried out, tests to verify that the quality management system is functioning correctly, if necessary. The notified body shall provide the manufacturer with a visit report and, if a test has taken place, with a test report.
5. Each notified body shall communicate to the other notified bodies the relevant information concerning the quality management system approvals, issued, withdrawn or refused.

The other notified bodies may receive on request copies of the quality management system approvals issued.

6. The manufacturer shall, for a period of 10 years after the last product has been manufactured, keep at the disposal of the national authorities:
 - the documentation referenced to in the second indent of point 3.1,
 - the updating referenced to in the second paragraph of point 3.4,

the decisions and reports from the notified body in the final paragraph of points 3.4, 4.3 and 4.4.

7. The manufacturer or his authorised representative established within the Community shall draw up the EC declaration of conformity of the interoperability constituent.

The content of this declaration shall include at least the information indicated in Annex IV (3) and in Article 13-3 of Directive 2001/16/EC. The EC declaration of conformity and the accompanying documents shall be dated and signed.

The declaration shall be written in the same language as the technical documentation and shall contain the following:

- the Directive references (Directive 2001/16/EC and other directives to which the interoperability constituent may be subject),
- the name and address of the manufacturer or his authorised representative established within the Community (give trade name and full address and in the case of an authorised representative also give the trade name of the manufacturer or constructor),
- description of the interoperability constituent (make, type, etc)

- description of the procedure (module) followed in order to declare conformity,
- all of the relevant descriptions met by the interoperability constituent and in particular any conditions of use,
- name and address of notified body (bodies) involved in the procedure followed in respect of conformity and date of certificates together with the duration and conditions of validity of the certificates,
- reference to the TSI and any other applicable TSI and where appropriate reference to European specification ⁽¹⁾,
- identification of the signatory empowered to enter into commitments on behalf of the manufacturer or of his authorised representative established within the Community.

The certificates to be referred to are:

- the quality management system approval indicated in point 3,
 - the type-examination certificate and its additions,
8. The manufacturer or his authorised representative established within the Community shall keep a copy of the EC declaration of conformity for a period of 10 years after the last interoperability constituent has been manufactured.

Where neither the manufacturer nor his authorised representative is established within the Community, the obligation to keep the technical documentation available is the responsibility of the person who places the interoperability constituent on the Community market.

9. If additional to the EC declaration of conformity an EC declaration of suitability for use for the interoperability constituent is requested in the TSI, this declaration has to be added, after being issued by the manufacturer under the conditions of Module V.

F.2.6. Module F: Product Verification

1. This module describes the procedure whereby a manufacturer or his authorised representative established within the Community checks and attests that the interoperability constituent concerned and subject to the provisions of point 3 is in conformity with the type as described in the EC type examination certificate and satisfies the requirements of the TSI that apply to it.
2. The manufacturer shall take all measures necessary in order that the manufacturing process ensures conformity of each interoperability constituent with the type as described in the type-examination certificate and with the requirements of the TSI that apply to it.
3. The notified body shall carry out the appropriate examinations and tests in order to check the conformity of the interoperability constituent with the type as described in the EC type examination certificate and with the requirements of the TSI. The manufacturer ⁽²⁾ can choose either an examination and testing of every interoperability constituent as specified in point 4 or an examination and testing of interoperability constituents on a statistical basis, as specified in point 5.
4. Verification by examination and testing of every interoperability constituent
 - 4.1. Each product shall be individually examined and appropriate tests shall be carried out in order to verify the product conformity with the type as described in the type-examination certificate and with the requirements of the TSI that apply to it. When a test is not set out in the TSI, (or in an European Standard quoted in the TSI), the relevant European Specifications ⁽³⁾, or equivalent tests are applicable.
 - 4.2. The notified body shall draw up a written certificate of conformity for the approved products relating to the tests carried out.
 - 4.3. The manufacturer or his authorised representative shall ensure that he is able to supply the notified body's certificates of conformity on request.

⁽¹⁾ The definition of an European specification is indicated in the directives 96/48/EC and 2001/16/EC. The guide for application of HS TSIs explains the way to use the European Specifications

⁽²⁾ The manufacturer's discretion may be limited in specific TSIs

⁽³⁾ The definition of an European specification is indicated in the directives 96/48/EEC and 2001/16/EC. The guide for application of HS TSIs explains the way to use the European Specifications

5. Statistical verification
- 5.1. The manufacturer shall present his interoperability constituents in the form of homogeneous lots and shall take all measures necessary in order that the manufacturing process ensures the homogeneity of each lot produced.
- 5.2. All interoperability constituents shall be available for verification in the form of homogeneous lots. A random sample shall be drawn from each lot. Each interoperability constituents in a sample shall be individually examined and appropriate tests shall be carried out to ensure the product conformity with the type as described in the type-examination certificate and with the requirements of the TSI which apply to it and to determine whether the lot is accepted or rejected. When a test is not set out in the TSI (or in an European Standard quoted in the TSI), the relevant European Specifications or equivalent tests are applicable..
- 5.3. The statistical procedure shall use appropriate elements (statistical method, sampling plan etc), depending on the characteristics to be assessed, as specified in the TSI.
- 5.4. In the case of accepted lots, the notified body shall draw up a written certificate of conformity relating to the tests carried out. All interoperability constituents in the lot may be placed on the market except those interoperability constituents from the sample, which were found not to be in conformity.

If a lot is rejected, the notified body or the competent authority shall take appropriate measures to prevent placing of that lot on the market. In the event of frequent rejection of lots the notified body shall suspend the statistical verification.

- 5.5. The manufacturer or his authorised representative established within the Community shall ensure that he is able to supply the notified body's certificates of conformity on request.
6. The manufacturer or his authorised representative established within the Community shall draw up the EC declaration of conformity of the interoperability constituent.

The content of this declaration shall include at least the information indicated in Annex IV (3) and in Article 13-3 of Directive 2001/16/EC. The EC declaration of conformity and the accompanying documents shall be dated and signed.

The declaration shall be written in the same language as the technical documentation and shall contain the following:

- the Directive references (Directive 2001/16/EC and other directives to which the interoperability constituent may be subject),
- the name and address of the manufacturer or his authorised representative established within the Community (give trade name and full address and in the case of an authorised representative also give the trade name of the manufacturer or constructor),
- description of interoperability constituent (make, type, etc)
- description of the procedure (module) followed in order to declare conformity,
- all of the relevant descriptions met by the interoperability constituent and in particular any conditions of use,
- name and address of notified body (bodies) involved in the procedure followed in respect of conformity and date of certificates together with the duration and conditions of validity of the certificates,
- reference to the TSI and any other applicable TSI and where appropriate reference to European specifications,
- identification of the signatory empowered to enter into commitments on behalf of the manufacturer or of his authorised representative established within the Community.

The certificates to be referred to are:

- the type-examination certificate and its additions,
- the certificate of conformity as mentioned in points 4 or 5.

7. The manufacturer or his authorised representative established within the Community shall keep a copy of the EC declaration of conformity for a period of 10 years after the last interoperability constituent has been manufactured.

Where neither the manufacturer nor his authorised representative is established within the Community, the obligation to keep the technical documentation available is the responsibility of the person who places the interoperability constituent on the Community market.

8. If additional to the EC declaration of conformity an EC declaration of suitability for use for the interoperability constituent is requested in the TSI, this declaration has to be added, after being issued by the manufacturer under the conditions of Module V.

F.2.7. Module H1: Full Quality Management System

1. This module describes the procedure whereby the manufacturer or his authorised representative established within the Community who satisfies the obligations of point 2, ensures and declares that the interoperability constituent concerned satisfies the requirements of the TSI that apply to it.
2. The manufacturer shall operate an approved quality management system for design, production and final product inspection and testing as specified in point 3 and shall be subject to surveillance as specified in point 4.
3. Quality management system
- 3.1. The manufacturer shall lodge an application for assessment of his quality management system with a notified body of his choice, for the interoperability constituents concerned.

The application shall include:

- all relevant information for the product category representative for the interoperability constituent envisaged,
- the quality management system's documentation.
- a written declaration that the same application has not been lodged with any other notified body,

- 3.2. The quality management system shall ensure compliance of the interoperability constituent with the requirements of the TSI that apply to it. All the elements, requirements and provisions adopted by the manufacturer shall be documented in a systematic and orderly manner in the form of written policies, procedures and instructions. This quality management system documentation shall ensure a common understanding of the quality policies and procedures such as quality programmes, plans, manuals and records.

It shall contain in particular an adequate description of:

- the quality objectives and the organisational structure,
- responsibilities and powers of the management with regard to design and product quality,
- the technical design specifications, including European specifications ⁽¹⁾, that will be applied, and, where the European specifications will not be applied in full, the means that will be used to ensure that the requirements of the TSI that apply to the interoperability constituent will be met,
- the design control and design verification techniques, processes and systematic actions that will be used when designing the interoperability constituents pertaining to the product category covered,
- the corresponding manufacturing, quality control and quality management system techniques, processes and systematic actions that will be used,
- the examinations, checks and tests that will be carried out before, during and after manufacture, and the frequency with which they will be undertaken,

⁽¹⁾ The definition of an European specification is indicated in the directives 96/48/EC and 2001/16/EC. The guide for application of HS TSIs explains the way to use the European Specifications

- the quality records, such as inspection reports and test data, calibration data, qualification reports of the personnel concerned, etc.,
- the means to monitor the achievement of the required design and product quality and the effective operation of the quality management system.

The quality policies and procedures shall cover in particular the assessment phases as design review, review of manufacturing process and type tests, as they are specified in the TSI, for the different characteristics and performances of the interoperability constituent.

- 3.3. The notified body shall assess the quality management system to determine whether it satisfies the requirements of point 3.2. It presumes compliance with these requirements if the manufacturer implements a quality system for design, production, final product inspection and testing in respect of the Standard EN/ISO 9001-2000, which take into consideration the specificity of the interoperability constituent for which it is implemented.

When the manufacturer operates a certified quality management system, the notified body shall take this into account in the assessment.

The audit shall be specific for the product category, which is representative for the interoperability constituent. The auditing team shall have at least one member experienced as an assessor in the product technology concerned. The evaluation procedure shall include an assessment visit to the manufacturer's premises.

The decision shall be notified to the manufacturer. The notification shall contain the conclusions of the examination and the reasoned assessment decision.

- 3.4. The manufacturer shall undertake to fulfil the obligations arising out of the quality management system as approved and to uphold it so that it remains adequate and efficient.

The manufacturer or his authorised representative established within the Community shall keep the notified body that has approved the quality management system informed of any intended updating of the quality management system.

The notified body shall evaluate the modifications proposed and decide whether the amended quality management system will still satisfy the requirements of point 3.2 or whether a re-assessment is required.

It shall notify its decision to the manufacturer. The notification shall contain the conclusions of the evaluation and the reasoned assessment decision.

4. Surveillance of the quality management system under the responsibility of the notified body
- 4.1. The purpose of surveillance is to make sure that the manufacturer duly fulfils the obligations arising out of the approved quality management system.
- 4.2. The manufacturer shall allow the notified body entrance for inspection purposes to the locations of design, manufacture, inspection and testing, and storage, and shall provide it with all necessary information, including particular:
- the quality management system documentation,
 - the quality records as foreseen by the design part of the quality management system, such as results of analyses, calculations, tests, etc.,
 - the quality records as foreseen by the manufacturing part of the quality management system, such as inspection reports and test data, calibration data, qualification reports of the personnel concerned, etc.
- 4.3. The notified body shall periodically carry out audits to make sure that the manufacturer maintains and applies the quality management system and shall provide an audit report to the manufacturer. When the manufacturer operates a certified quality management system, the notified body shall take this into account in the surveillance.

The frequency of the audits shall be at least once a year.

- 4.4. Additionally the notified body may pay unexpected visits to the manufacturer. At the time of such visits, the notified body may carry out tests or have them carried out in order to check the proper functioning of the quality management system where necessary. It shall provide the manufacturer with a visit report and, if a test has been carried out, with a test report.
5. The manufacturer shall, for a period of 10 years after the last product has been manufactured, keep at the disposal of the national authorities:
- the documentation referenced to in the second indent of the second subparagraph of point 3.1,
 - the updating referenced in the second subparagraph of point 3.4,
 - the decisions and reports from the notified body in the final subparagraph of points 3.4, 4.3 and 4.4.
6. Each notified body shall communicate to the other notified bodies the relevant information concerning the quality management system approvals issued, withdrawn or refused.

The other notified bodies may receive on request copies of the quality management system approvals and additional approvals issued.

7. The manufacturer or its authorised representative established within the Community shall draw up the EC Declaration of conformity of the interoperability constituent.

The content of this declaration shall include at least the information indicated in Annex IV (3) and in Article 13-3 of Directive 2001/16/EC. The EC declaration of conformity and the accompanying documents shall be dated and signed.

The declaration shall be written in the same language as the technical documentation and shall contain the following:

- the Directive references (Directive 2001/16/EC and other directives to which the interoperability constituent may be subject)
- the name and address of the manufacturer or his authorised representative established within the Community (give trade name and full address and in the case of an authorised representative also give the trade name of the manufacturer or constructor),
- description of interoperability constituent (make, type, etc)
- description of the procedure (module) followed in order to declare conformity,
- all of the relevant descriptions met by the interoperability constituent and in particular its conditions of use,
- name and address of notified body (bodies) involved in the procedure followed in respect of conformity, and date of certificate together with the duration and conditions of validity of the certificate,
- reference to the TSI and to any other applicable TSI and where appropriate to European specifications,
- identification of the signatory empowered to enter into commitments on behalf of the manufacturer or of his authorised representative established within the Community.

The certificate to be referred to is:

- the Quality management system approvals indicated in point 3.
8. The manufacturer or his authorised representative established within the Community shall keep a copy of the EC declaration of conformity for a period of 10 years after the last interoperability constituent has been manufactured.

Where neither the manufacturer nor his authorised representative is established within the Community, the obligation to keep the technical documentation available is the responsibility of the person who places the interoperability constituent on the Community market.

9. If additional to the EC declaration of conformity an EC declaration of suitability for use for the interoperability constituent is requested in the TSI, this declaration has to be added, after being issued by the manufacturer under the conditions of Module V.

F.2.8. Module H2: Full Quality Management System With Design Examination

1. This module describes the procedure whereby a notified body carries out an examination of the design of an interoperability constituent and the manufacturer or his authorised representative established within the Community who satisfies the obligations of point 2 ensures and declares that the interoperability constituent concerned satisfies the requirements of the TSI that apply to it.
2. The manufacturer shall operate an approved quality management system for design, production and final product inspection and testing as specified in point 3 and shall be subject to surveillance as specified in point. 4.
3. Quality management system.
- 3.1. The manufacturer shall lodge an application for assessment of his quality management system with a notified body of his choice, for the interoperability constituents concerned.

The application shall include:

- all relevant information for the product category representative for the interoperability constituent envisaged,
 - the quality management system's documentation.
 - a written declaration that the same application has not been lodged with any other notified body,
- 3.2. The quality management system shall ensure compliance of the interoperability constituent with the requirements of the TSI that apply to it. All the elements, requirements and provisions adopted by the manufacturer shall be documented in a systematic and orderly manner in the form of written policies, procedures and instructions. This quality management system documentation shall ensure a common understanding of the quality policies and procedures such as quality programmes, plans, manuals and records.

It shall contain in particular an adequate description of:

- the quality objectives and the organisational structure,
- responsibilities and powers of the management with regard to design and product quality,
- the technical design specifications, including European specifications ⁽¹⁾, that will be applied, and, where the European specifications will not be applied in full, the means that will be used to ensure that the requirements of the TSI that apply to the interoperability constituent will be met,
- the design control and design verification techniques, processes and systematic actions that will be used when designing the interoperability constituents pertaining to the product category covered,
- the corresponding manufacturing, quality control and quality management system techniques, processes and systematic actions that will be used,
- the examinations, checks and tests that will be carried out before, during and after manufacture, and the frequency with which they will be undertaken,
- the quality records, such as inspection reports and test data, calibration data, qualification reports of the personnel concerned, etc.,
- the means to monitor the achievement of the required design and product quality and the effective operation of the quality management system.

⁽¹⁾ The definition of an European specification is indicated in the directives 96/48/EC and 2001/16/EC. The guide for application of HS TSIs explains the way to use the European Specifications

The quality policies and procedures shall cover in particular the assessment phases, such as design review, review of manufacturing processes and type tests, as they are specified in the TSI, for different characteristics and performances of the interoperability constituent.

- 3.3. The notified body shall assess the quality management system to determine whether it satisfies the requirements of point 3.2. It presumes compliance with these requirements if the manufacturer implements a quality system for design, production, final product inspection and testing in respect of the Standard EN/ISO 9001-2000, which takes into consideration the specificity of the interoperability constituent for which it is implemented.

When the manufacturer operates a certified quality management system, the notified body shall take this into account in the assessment.

The audit shall be specific for the product category, which is representative for the interoperability constituent. The auditing team shall have at least one member experienced as an assessor in the product technology concerned. The evaluation procedure shall include an assessment visit to the manufacturer's premises.

The decision shall be notified to the manufacturer. The notification shall contain the conclusions of the audit and the reasoned assessment decision.

- 3.4. The manufacturer shall undertake to fulfil the obligations arising out of the quality management system as approved and to uphold it so that it remains adequate and efficient.

The manufacturer or his authorised representative established within the Community shall keep the notified body that has approved the quality management system informed of any intended updating of the quality management system.

The notified body shall evaluate the modifications proposed and decide whether the amended quality management system will still satisfy the requirements of point 3.2 or whether a re-assessment is required.

It shall notify its decision to the manufacturer. The notification shall contain the conclusions of the evaluation and the reasoned assessment decision.

4. Surveillance of the quality management system under the responsibility of the notified body
- 4.1. The purpose of surveillance is to make sure that the manufacturer duly fulfils the obligations arising out of the approved quality management system.
- 4.2. The manufacturer shall allow the notified body entrance for inspection purposes to the locations of design, manufacture, inspection and testing, and storage, and shall provide it with all necessary information, including:
- the quality management system documentation,
 - the quality records as foreseen by the design part of the quality management system, such as results of analyses, calculations, tests, etc.,
 - the quality records as foreseen by the manufacturing part of the quality management system, such as inspection reports and test data, calibration data, qualification reports of the personnel concerned, etc.
- 4.3. The notified body shall periodically carry out audits to make sure that the manufacturer maintains and applies the quality management system and shall provide an audit report to the manufacturer. When the manufacturer operates a certified quality management system, the notified body shall take this into account in the surveillance.

The frequency of the audits shall be at least once a year.

- 4.4. Additionally the notified body may pay unexpected visits to the manufacturer. At the time of such visits, the notified body may carry out tests or have them carried out in order to check the proper functioning of the quality management system where necessary. It shall provide the manufacturer with a visit report and, if a test has been carried out, with a test report.

5. The manufacturer shall, for a period of 10 years after the last product has been manufactured, keep at the disposal of the national authorities:
 - the documentation referenced in the second indent of the second subparagraph of point 3.1,
 - the updating referenced to in the second subparagraph of point 3.4,
 - the decisions and reports from the notified body in the final subparagraph of points 3.4, 4.3 and 4.4.

6. Design examination

- 6.1. The manufacturer shall lodge an application for examination of the design of the interoperability constituent with a notified body of his choice
- 6.2. The application shall enable the design, manufacture, maintenance and operation of the interoperability constituent to be understood, and shall enable conformity with the requirements of the TSI to be assessed.

It shall include:

- a general type-description,
 - the technical design specifications, including European specifications, with relevant clauses, that have been applied in full or in part,
 - any necessary supporting evidence for their adequacy, in particular where the European specifications and the relevant clauses have not been applied,
 - the test programme
 - conditions for integration of the interoperability constituent in its system environment (sub-assembly, assembly, subsystem) and the necessary interface conditions,
 - conditions for use and maintenance of the interoperability constituent (restrictions of running time or distance, wear limits etc),
 - a written declaration that the same application has not been lodged with any other notified body,
- 6.3. The applicant shall present the results of tests ⁽¹⁾, including type tests when required, carried out by its appropriate laboratory or on their behalf.
 - 6.4. The notified body shall examine the application and assess the results of the tests. Where the design meets the provisions of the TSI that apply to it, the notified body shall issue an EC design examination certificate to the applicant. The certificate shall contain the conclusions of the examination, conditions for its validity, the necessary data for identification of the approved design and, if relevant, a description of the product's functioning.

The time period of validity shall be no longer than 5 years.

- 6.5. The applicant shall keep the notified body that has issued the EC design examination certificate informed of all modifications to the approved design, which may affect the conformity with the requirements of the TSI or the prescribed conditions for use of the interoperability constituent. In such cases the interoperability constituent shall receive additional approval from the notified body that issued the EC design examination certificate. In this case, the notified body shall perform only those examinations and tests that are relevant and necessary to the changes. The additional approval shall be given in the form of an addition to the original EC design examination certificate.
- 6.6. If no modifications as in point 6.4. have been made, the validity of an expiring certificate can be extended for another period of validity. The applicant will apply for such a prolongation by a written confirmation that no such modifications have been made, and the notified body issues a prolongation for another period of validity as in point 6.3. if no contrary information exists. This procedure can be reiterated.

⁽¹⁾ The presentation of the results of the tests can be at the same time as the application or later.

7. Each notified body shall communicate to the other notified bodies the relevant information concerning the quality management system approvals and the EC design examination certificates, which it has issued, withdrawn or refused.

The other notified bodies may receive on request copies of:

- the quality management system approvals and additional approvals issued and
- the EC design examination certificates and additions issued

8. The manufacturer or his authorised representative established within the Community shall draw up the EC declaration of conformity of the interoperability constituent.

The content of this declaration shall include at least the information indicated in Annex IV (3) and in Article 13-3 of Directive 2001/16/EC. The EC declaration of conformity and its accompanying documents shall be dated and signed.

The declaration shall be written in the same language as the technical documentation and shall contain the following:

- the Directive references (Directive 2001/16/EC and other directives to which the interoperability constituent may be subject),
- the name and address of the manufacturer or his authorised representative established within the Community (give trade name and full address and in the case of an authorised representative also give the trade name of the manufacturer or constructor),
- description of interoperability constituent (make, type, etc)
- description of the procedure (module) followed in order to declare conformity,
- all of the relevant descriptions met by the interoperability constituent and in particular any conditions of use,
- name and address of notified body (bodies) involved in the procedure followed in respect of conformity and date of certificates together with the duration and conditions of validity of the certificates,
- reference to the TSI and any other applicable TSI and where appropriate to European specifications,
- identification of the signatory empowered to enter into commitments on behalf of the manufacturer or of his authorised representative established within the Community.

The certificates to be referred to are:

- the quality management system approval and surveillance reports indicated in point 3 and 4,
- the EC design examination certificate and its additions.

9. The manufacturer or his authorised representative established within the Community shall keep a copy of the EC declaration of conformity for a period of 10 years after the last interoperability constituent has been manufactured.

Where neither the manufacturer nor his authorised representative is established within the Community, the obligation to keep the technical documentation available is the responsibility of the person who places the interoperability constituent on the Community market.

10. If additional to the EC declaration of conformity an EC declaration of suitability for use for the interoperability constituent is requested in the TSI, this declaration has to be added, after being issued by the manufacturer under the conditions of Module V.

F.2.9. Module V: Type-Validation By In Service Experience (Suitability For Use)

1. This module describes that part of the procedure by which a notified body ascertains and attests that a specimen, representative of the production envisaged, meets the provisions of the TSI that apply to it for suitability for use, by type validation as demonstrated through in service experience ⁽¹⁾.
2. The manufacturer, or his authorised representative established within the Community, shall lodge the application for the type-validation by in service experience with a notified body of his choice.

The application shall include:

- the name and address of the manufacturer and also, if the application is lodged by the authorised representative, his name and address,
- a written declaration that the same application has not been lodged with any other notified body,
- the technical documentation, as described in point 3,
- the programme for validation by in service experience, as described in point 4,
- the name and address of the company(ies) (infrastructure managers and/or railway enterprises), with which the applicant has obtained an agreement to contribute to a suitability for use assessment by in service experience
- by operating the interoperability constituent in service,
- by monitoring the in service behaviour and
- by issuing a report about in service experience,
- the name and the address of the company undertaking the maintenance of the interoperability constituent during the time period or running distance required for in service experience,
- an EC declaration of conformity for the interoperability constituent and,
- if module B is required in the TSI, an EC type examination certificate,
- if module H2 is required in the TSI, an EC design examination certificate.

The applicant shall place at the disposal of the company(ies), undertaking the operation of the interoperability constituent in service a specimen or a sufficient number of specimens, representative of the production envisaged and hereinafter called 'type'. A type may cover several versions of the interoperability constituent provided that the differences between the versions are all covered by EC declarations of conformity and certificates as mentioned above.

The notified body may request further specimens if needed for carrying out the validation by in service experience to be put in service.

3. The technical documentation shall enable the assessment of the product with the requirements of the TSI. The documentation shall cover the operation of the interoperability constituent, and, as far as relevant for such assessment, cover also the design, manufacture and maintenance.

The technical documentation shall contain

- a general type-description,
- the technical specification, against which the performance and in service behaviour of the interoperability constituent is to be assessed (relevant TSI and/or European Specifications with relevant clauses),
- conditions of integration of the interoperability constituent in its system environment (sub-assembly, assembly, subsystem) and the necessary interface conditions,

⁽¹⁾ During the time of in service experience, the IC is not placed on the market.

- conditions for use and maintenance of the interoperability constituent (restrictions of running time or distance, wear limits etc),
- descriptions and explanations necessary for the understanding of the design, manufacture and operation of the interoperability constituent;

and, as far as is relevant for assessment,

- conceptual design and manufacturing drawings,
- results of design calculations made and examinations carried out,
- test reports.

If the TSI requires further information for the technical documentation, this shall be included.

A list of the European specifications referenced to in the technical documentation, applied in full or in part, shall be attached.

4. The programme for the validation by in service experience shall include:
 - the required performance or behaviour in service of the interoperability constituent under trial,
 - the installation arrangements,
 - the duration of the programme — either time or distance -
 - the operating conditions and the service programme expected,
 - the maintenance programme,
 - the special in service tests, if any, to be performed,
 - the batch size of the specimens — if more than one,
 - the inspection programme (nature, number and frequency of inspections, documentation),
 - criteria for tolerable defects and their impact on the programme,
 - the information to be included in the report of the company operating the interoperability constituent in service (see point 2).
5. The notified body shall:
 - 5.1. Examine the technical documentation and the programme for validation by in service experience,
 - 5.2. Verify that the type is representative and has been manufactured in conformity with the technical documentation,
 - 5.3. Verify that the programme for validation by in service experience is well adapted to assess the required performance and in service behaviour of the interoperability constituent,
 - 5.4. Agree with the applicant the programme and the location where the inspections and necessary tests will be carried out and the body performing the tests (notified body or other competent laboratory),
 - 5.5. Monitor and inspect the progress of in service running, operation and maintenance of the interoperability constituent,
 - 5.6. Evaluate the report, to be issued by the company (ies) (infrastructure managers and/or railway enterprises) operating the interoperability constituent, and all other documentation and information, gained during the procedure (test reports, maintenance experience etc),
 - 5.7. Assess, if the in service behaviour meets the requirements of the TSI.

6. Where the type meets the provisions of the TSI, the notified body shall issue a suitability for use certificate to the applicant. The certificate shall contain the name and address of the manufacturer, conclusions of the validation, conditions for its validity and the necessary data for identification of the approved type.

The time period of validity shall be no longer than 5 years.

A list of the relevant parts of the technical documentation shall be annexed to the certificate and a copy kept by the notified body.

If the applicant is denied a suitability for use certificate, the notified body shall provide detailed reasons for such denial.

Provision shall be made for an appeals procedure.

7. The applicant shall inform the notified body that holds the technical documentation concerning the suitability for use certificate of all modifications to the approved product which shall receive additional approval where such changes may affect the suitability for use or the prescribed conditions for use of the product. In this case, the notified body shall perform only those examinations and tests, that are relevant and necessary to the changes. The additional approval may be given in the form of an addition to the original suitability for use certificate, or by issue of a new certificate issued after withdrawal of the old certificate.
8. If no modifications as in point 7 have been made, the validity of an expiring certificate can be extended for another period of validity. The applicant will apply for such a prolongation by a written confirmation that no such modifications have been made, and the notified body issues a prolongation for another period of validity as in point 6, if no contrary information exists. This procedure can be reiterated.
9. Each notified body shall communicate to the other notified bodies the relevant information concerning the suitability for use certificates issued, withdrawn or refused.
10. The other notified bodies shall be provided on request with copies of the suitability for use certificates issued and/or their additions. The annexes to the certificates shall be kept at the disposal of the other notified bodies.
11. The manufacturer or his authorised representative established within the Community shall draw up the EC declaration of suitability for use of the interoperability constituent.

The content of this declaration shall include at least the information, indicated in Annex IV (3) and in Article 13-3 of Directive 2001/16/EC. The EC declaration of suitability for use and the accompanying documents shall be dated and signed.

The declaration shall be written in the same language as the technical documentation and shall contain the following:

- the Directive references (Directive 2001/16/EC),
- the name and address of the manufacturer or his authorised representative established within the Community (give trade name and full address and in the case of an authorised representative also give the trade name of the manufacturer or constructor),
- description of interoperability constituent (make, type, etc)
- all of the relevant descriptions met by the interoperability constituent and in particular any conditions of use,
- name and address of notified body (bodies) involved in the procedure followed in respect of suitability for use and date of suitability for use certificate together with the duration and conditions of validity of the certificate,
- reference to this TSI and to any other applicable TSI, and where appropriate reference to European specification,
- identification of the signatory empowered to enter into commitments on behalf of the manufacturer or of his authorised representative established within the Community.

12. The manufacturer or his authorised representative established within the Community shall keep a copy of the EC declaration of suitability for use for a period of 10 years after the last interoperability constituent has been manufactured.

Where neither the manufacturer nor his authorised representative is established within the Community, the obligation to keep the technical documentation available is the responsibility of the person who places the interoperability constituent on the Community market.

F.3. Modules for the EC Verification of Subsystems

Note: in this section F.3, subsystem means rolling stock subsystem or, where relevant, energy subsystem.

F.3.1. Module SB: Type Examination

1. This module describes the EC verification procedure whereby a notified body checks and certifies at the request of an contracting entity or its authorised representative established within the Community, that a type of a subsystem, representative of the production envisaged,

- complies with this TSI and any other applicable TSI, which demonstrate that the essential requirements ⁽¹⁾ of Directive 01/16/EC have been met
- complies with the other regulations deriving from the Treaty.

The type examination defined by this module could include specific assessment phases — design review, type test or review of manufacturing process, which are specified in the relevant TSI.

2. The contracting entity ⁽²⁾ shall lodge an application for EC verification (through type examination) of the subsystem with a notified body of his choice.

The application shall include:

- name and address of the contracting entity or its authorised representative
- the technical documentation, as described in point 3.

3. The applicant shall place at the disposal of the notified body a specimen of the subsystem ⁽³⁾, representative of the production envisaged and hereinafter called 'type'.

A type may cover several versions of the subsystem provided that the differences between the versions do not affect the provisions of the TSI.

The notified body may request further specimens if needed for carrying out the test programme.

If so required for specific test or examination methods and specified in the TSI or in the European specification ⁽⁴⁾ referenced to in the TSI, a specimen or specimens of a subassembly or assembly or a specimen of the subsystem in a pre-assembled condition shall to be provided.

The technical documentation and specimen(s) shall enable the design, manufacture, installation, maintenance and operation of the subsystem to be understood, and shall enable conformity with the provisions of the TSI to be assessed.

The technical documentation shall include:

- a general description of the subsystem, overall design and structure,

⁽¹⁾ The essential requirements are reflected in the technical parameters, interfaces and performance requirements, which are set out in Chapter 4 of the TSI.

⁽²⁾ In the module, 'the contracting entity' means 'the subsystem contracting entity, as defined in the directive, or his authorised representative established within the Community'.

⁽³⁾ The relevant section of a TSI may define specific requirements in this regard.

⁽⁴⁾ The definition of an European specification is indicated in the directives 96/48/EC and 2001/16/EC. The guide for application of HS TSIs explains the way to use the European Specifications

- the rolling stock register, including all information as specified in the TSI
- conceptual design and manufacturing information, for example drawings, schemes of components, sub-assemblies, assemblies, circuits, etc.,
- descriptions and explanations necessary for the understanding of the design and manufacturing information, the maintenance and the operation of the subsystem,
- the technical specifications, including European specifications, that have been applied,
- any necessary supporting evidence for the use of the above specifications, in particular where European specifications and the relevant clauses have not been applied in full,
- a list of the interoperability constituents to be incorporated into the subsystem,
- copies of the EC declarations of conformity or suitability for use of interoperability constituents and all the necessary elements defined in annex VI of the directives,
- evidence of conformity with the other regulations deriving from the treaty (including certificates)
- technical documentation regarding the manufacture and the assembly of the subsystem,
- a list of manufacturers, involved in the subsystem's design, manufacturing, assembly and installation,
- conditions for use of the subsystem (restrictions of running time or distance, wear limits etc),
- conditions for maintenance and technical documentation regarding the maintenance of the subsystem
- any technical requirement that shall be taken into account during production, maintenance or operation of the subsystem
- results of design calculations made, examinations carried out, etc.,
- test reports.

If the TSI requires further information for the technical documentation, this shall be included.

4. The notified body shall:
 - 4.1. Examine the technical documentation,
 - 4.2. Verify that the specimen(s) of the subsystem or of assemblies or subassemblies of the subsystem, has (have) been manufactured in conformity with the technical documentation, and carry out or have carried out the type tests in accordance with the provisions of the TSI and the appropriate European specifications. Such manufacture shall be verified using an appropriate assessment module.
 - 4.3. Where a design review is requested in the TSI, perform an examination of the design methods, the design tools and the design results to evaluate their capability to fulfil the requirements for conformity for the subsystem at the completion of the design process
 - 4.4. Identify the elements which have been designed in accordance with the relevant provisions of the TSI and the European specifications as well as the elements which have been designed without applying the relevant provisions of those European specifications;
 - 4.5. Perform or have performed the appropriate examinations and necessary tests in accordance with points 4.2. and 4.3 to establish where the relevant European specifications have been chosen, these have actually been applied;
 - 4.6. Perform or have performed the appropriate examinations and necessary tests in accordance with point 4.2. and 4.3. to establish whether the solutions adopted meet the requirements of the TSI when the appropriate European specifications have not been applied.
 - 4.7. Agree with the applicant the location where the examinations and necessary tests will be carried out.

5. Where the type meets the provisions of the TSI, the notified body shall issue a type-examination certificate to the applicant. The certificate shall contain the name and address of the contracting entity and the manufacturer(s) indicated in the technical documentation, conclusions of the examination, conditions for its validity and the necessary data for identification of the approved type.

A list of the relevant parts of the technical documentation shall be annexed to the certificate and a copy kept by the notified body.

If the contracting entity is denied a type-examination certificate, the notified body shall provide detailed reasons for such denial.

Provision shall be made for an appeals procedure.

6. Each notified body shall communicate to the other notified bodies the relevant information concerning the type-examination certificates issued, withdrawn or refused
7. The other notified bodies may receive on request copies of the type-examination certificates issued and/or their additions. The annexes to the certificates shall be kept at the disposal of the other notified bodies.
8. The contracting entity shall keep with the technical documentation copies of type-examination certificates and any additions throughout the service life of the subsystem. It shall be sent to any Member State which so requests.
9. During the production phase, the applicant shall inform the notified body that holds the technical documentation concerning the type-examination certificate of all modifications which may affect the conformity with the requirements of the TSI or the prescribed conditions for use of the subsystem. The subsystem shall receive additional approval in such cases. In this case, the notified body shall perform only those examinations and tests, those are relevant and necessary to the changes. This additional approval may be given either in the form of an addition to the original type-examination certificate, or by issue of a new certificate after withdrawal of the old certificate.

F.3.2. Module SD: Production Quality Management System

1. This module describes the EC verification procedure whereby a notified body checks and certifies, at the request of an contracting entity or its authorised representative established within the Community, that a subsystem, for which already a type-examination certificate has been issued by a notified body,
- complies with this TSI and any other applicable TSI, which demonstrate that the essential requirements ⁽¹⁾ of Directive 2001/16/EC have been met
 - complies with the other regulations deriving from the Treaty,
- and may be placed in service.
2. The notified body carries out the procedure, under the condition, that:
- the type examination certificate issued prior to the assessment remains valid for the subsystem subject to the application,
 - the contracting entity ⁽²⁾ and the main contractor involved are satisfying the obligations of point 3.

The 'main contractor' refers to companies, whose activities contribute to fulfil the essential requirements of the TSI. It concerns:

- the company responsible for the whole subsystem project (including in particular responsibility for subsystem integration),
- other companies only involved in a part of the subsystem project, (performing for example assembly or installation of the subsystem).

It does not refer to manufacturer sub contractors supplying components and interoperability constituents.

⁽¹⁾ The essential requirements are reflected in the technical parameters, interfaces and performance requirements, which are set out in Chapter 4 of the TSI.

⁽²⁾ In the module, 'the contracting entity' means 'the subsystem contracting entity, as defined in the directive, or his authorised representative established within the Community'.

3. For the subsystem that is subject of the EC verification procedure, the contracting entity, or the main contractor when employed, shall operate an approved quality management system for manufacture and final product inspection and testing as specified in point 5 and which shall be subject to surveillance as specified in point 6.

When the contracting entity itself is responsible for the whole subsystem project (including in particular responsibility for subsystem integration), or the contracting entity is directly involved in the production (including assembly and installation), it has to operate an approved quality management system for those activities, which shall be subject to surveillance as specified in point 6.

If a main contractor is responsible for the whole subsystem project (including in particular responsibility for subsystem integration), it shall operate in any case an approved quality management system for manufacture and final product inspection and testing, which shall be subject to surveillance as specified in point 6.

4. EC verification procedure
 - 4.1. The contracting entity shall lodge an application for EC verification of the subsystem (through production quality management system), including co-ordination of the surveillance of the quality management systems, as under point 5.3 and 6.5. with a notified body of its choice. The contracting entity shall inform the manufacturers involved of this choice and of the application.
 - 4.2. The application shall enable the design, manufacture, assembly, installation, maintenance and operation of the subsystem to be understood, and shall enable conformity with the type as described in the type-examination certificate and the requirements of the TSI to be assessed.

The application shall include:

- name and address of the contracting entity or its authorised representative
- the technical documentation regarding the approved type, including the type examination certificate, as issued after completion of the procedure defined in module SB,

and, if not included in this documentation,

- a general description of the subsystem, its overall design and structure,
- the technical specifications, including European specifications ⁽¹⁾, that have been applied,
- any necessary supporting evidence for the use of the above specifications, in particular where these European specifications, and the relevant clauses have not been applied in full. This supporting evidence shall include the results of tests carried out by the appropriate laboratory of the manufacturer or on his behalf.
- the rolling stock register, including all information as specified in the TSI,
- the technical documentation regarding the manufacture and the assembly of the subsystem,
- evidence of conformity to other regulations deriving from the treaty (including certificates) for the production phase
- a list of the interoperability constituents to be incorporated into the subsystem,
- copies of the EC declarations of conformity or suitability for use with which the constituents shall be provided, and all the necessary elements defined in annex VI of the directives,
- a list of manufacturers, involved in the subsystem's design, manufacturing, assembly and installation,
- the demonstration, that all stages, as mentioned under point 5.2, are covered by quality management systems of the contracting entity, if involved, and/or of the main contractor, and the evidence of their effectiveness,
- indication of the notified body, responsible for the approval and surveillance of these quality management systems.

⁽¹⁾ The definition of an European specification is indicated in the directives 96/48/EC and 2001/16/EC. The guide for application of HS TSIs explains the way to use the European Specifications

- 4.3. The notified body shall first examine the application concerning the validity of the type examination and the type examination certificate.

If the notified body considers the type examination certificate no longer remains valid or is not appropriate and that a new type examination is necessary, it shall justify its decision.

5. Quality management system

- 5.1. The contracting entity, if involved, and the main contractor, when employed, shall lodge an application for assessment of their quality management systems with a notified body of their choice.

The application shall include:

- all relevant information for the subsystem envisaged,
- the quality management system documentation.
- the technical documentation of the approved type and a copy of the type examination certificate, issued after the completion of the type examination procedure of module SB.

For those only involved in a part of the subsystem project, the information to be provided is only that for the relevant part.

- 5.2. For the contracting entity or the main contractor responsible for the whole subsystem project, the quality management systems shall ensure overall compliance of the subsystem with the type as described in the type-examination certificate and overall compliance of the subsystem with the requirements of the TSI. For other contractors, their quality management system(s) has (have) to ensure compliance of their relevant contribution to the subsystem with the type as described in the type-examination certificate and with the requirements of the TSI.

All the elements, requirements and provisions adopted by the applicant(s) shall be documented in a systematic and orderly manner in the form of written policies, procedures and instructions. This quality management system documentation shall ensure a common understanding of the quality policies and procedures such as quality programmes, plans, manuals and records.

It shall contain in particular an adequate description of the following items for all applicant(s):

- the quality objectives and the organisational structure,
- the corresponding manufacturing, quality control and quality management techniques, processes and systematic actions that will be used,
- the examinations, checks and tests that will be carried out before, during and after manufacture, assembly and installation, and the frequency with which they will be carried out,
- the quality records, such as inspection reports and test data, calibration data, qualification reports of the personnel concerned, etc.,

and also for the contracting entity or the main contractor responsible for the whole subsystem project:

- responsibilities and powers of the management with regard to overall subsystem quality, including in particular the subsystem integration management.

The examinations, tests and checking shall cover all of the following stages:

- structure of subsystem, including, in particular, civil-engineering activities, constituent assembly, final adjustment,
- final testing of the subsystem,
- and, where specified in the TSI, the validation under full operation conditions.

- 5.3. The notified body chosen by the contracting entity shall examine, if all stages of the subsystem as mentioned under point 5.2 are sufficiently and properly covered by the approval and surveillance of the quality management system(s) of the applicant(s) ⁽¹⁾.

If the conformity of the subsystem with the type as described in the type-examination certificate and the compliance of the subsystem with the requirements of the TSI is based on more than one quality management system, the notified body shall examine in particular,

- if the relations and interfaces between the quality management systems are clearly documented
- and if overall responsibilities and powers of the management for the compliance of the whole entire subsystem for the main contractor are sufficiently and properly defined.

- 5.4. The notified body referenced to in point 5.1. shall assess the quality management system to determine whether it satisfies the requirements referenced in point 5.2. It presumes compliance with these requirements if the applicant implements a quality system for production, final product inspection and testing in respect of the Standard EN/ISO 9001-2000, which takes into consideration the specificity of the subsystem for which it is implemented.

When an applicant operates a certified quality management system, the notified body shall take this into account in the assessment.

The audit shall be specific for the subsystem concerned, taking into consideration the specific contribution of the applicant to the subsystem. The auditing team shall have at least one member experienced as an assessor in the subsystem technology concerned. The evaluation procedure shall include an assessment visit to the applicant's premises.

The decision shall be notified to the applicant. The notification shall contain the conclusions of the examination and the reasoned assessment decision.

- 5.5. The contracting entity, if involved, and the main contractor shall undertake to fulfil the obligations arising out of the quality management system as approved and to uphold it so that it remains adequate and efficient.

They shall keep the notified body that has approved the quality management system, informed of any significant change that will affect the fulfilment of the TSI requirements by the subsystem.

The notified body shall evaluate the modifications proposed and decide whether the amended quality management system will still satisfy the requirements referenced in point 5.2 or whether a re-assessment is required.

It shall notify its decision to the applicant. The notification shall contain the conclusions of the examination and the reasoned assessment decision.

6. Surveillance of the quality management system(s) under the responsibility of the notified body

- 6.1. The purpose of surveillance is to make sure that the contracting entity, if involved, and the main contractor, duly fulfil the obligations arising out of the approved quality management system(s).

- 6.2. The contracting entity, if involved, and the main contractor shall send to the notified body referenced in point 5.1 (or have sent) all the documents needed for that purpose including the implementation plans and technical records concerning the subsystem (as far as relevant for the specific contribution of the applicants to the subsystem), in particular:

- the quality management system documentation, including the particular means implemented to ensure that:
- for the contracting entity or main contractor, responsible for the whole subsystem project,
 - overall responsibilities and powers of the management for the compliance of the whole entire subsystem are sufficiently and properly defined,
- for each applicant,

the quality management system is correctly managed for achieving integration at subsystem level,

⁽¹⁾ For the rolling stock TSI, the notified body may participate to the final in service test of locomotives or train set in the conditions specified in the relevant chapter of the TSI.

- the quality records as foreseen by the manufacturing part (including assembly and installation) of the quality management system, such as inspection reports and test data, calibration data, qualification reports of the personnel concerned, etc.

6.3. The notified body shall periodically carry out audits to make sure that the contracting entity, if involved, and the main contractor, maintain and apply the quality management system and shall provide an audit report to them. When those operate a certified quality management system, the notified body shall take this into account in the surveillance.

The frequency of the audits shall be at least once a year, with at least one audit during the time period of performing relevant activities (manufacture, assembly or installation) of the subsystem being the subject of the EC verification procedure mentioned under point 8.

6.4. Additionally the notified body may pay unexpected visits to the relevant sites of the applicant(s). At the time of such visits, the notified body may conduct complete or partial audits and may carry out or cause to be carried out tests, in order to check the proper functioning of the quality management system where necessary. It shall provide the applicant(s) with an inspection report and also, audit and/or test reports, as appropriate.

6.5. The notified body chosen by the contracting entity and responsible for the EC verification, if not carrying out the surveillance of all the quality management system(s) concerned, shall co ordinate the surveillance activities of any other notified body responsible for that task, in order:

- to be ensured that correct management of interfaces between the different quality management systems relating to subsystem integration has been performed,
- to collect, in liaison with the contracting entity, the necessary elements for the assessment to guarantee the consistency and the overall supervision of the different quality management systems.

This co ordination includes the rights of the notified body:

- to receive all documentation (approval and surveillance), issued by the other notified bodies,
- to witness the surveillance audits in point 6.3,
- to initiate additional audits as in point 6.4 under its responsibility and together with the other notified bodies.

7. The notified body as referenced in point 5.1. shall have entrance for inspection purposes, audit and surveillance to the locations of building sites, production workshops, locations of assembly and installations, storage areas and where appropriate, prefabrication and testing facilities and, more general, to all premises which it considers necessary in order to carry out its tasks, in accordance with the applicant's specific contribution to the subsystem project.

8. The contracting entity, if involved, and the main contractor shall, for a period of 10 years after the last subsystem has been manufactured, keep at the disposal of the national authorities:

- the documentation referenced in the second indent of the second subparagraph of point 5.1,
- the updating referenced in the second subparagraph of point 5.5,
- the decisions and reports from the notified body, which are, referenced in points 5.4, 5.5 and 6.4.

9. Where the subsystem meets the requirements of the TSI, the notified body shall then, based on the type examination and the approval and surveillance of the quality management system(s), draw up the certificate of conformity intended for the contracting entity, who shall in turn draw up the EC declaration of verification intended for the supervisory authority in the Member State within which the subsystem is located and/or operates.

The EC declaration of verification and the accompanying documents shall be dated and signed. The declaration shall be written in the same language of the technical file and shall contain at least the information included in Annex V of the Directive.

10. The notified body chosen by the contracting entity shall be responsible for compiling the technical file that has to accompany the EC declaration of verification. The technical file shall include at least the information indicated in the Art 18 (3) of the Directive, and in particular as follows:
- all necessary documents relating to the characteristics of the subsystem,
 - a list of interoperability constituents incorporated into the subsystem,
 - copies of the EC declarations of conformity and, where appropriate, of the EC declarations of suitability for use, which said constituents shall be provided in accordance with Article 13 of the Directive, accompanied, where appropriate, by the corresponding documents (certificates, quality management system approvals and surveillance documents) issued by the notified bodies,
 - all elements relating to the maintenance, the conditions and limits for use of the subsystem,
 - all elements relating to the instructions concerning servicing, constant or routine monitoring, adjustment and maintenance,
 - the type-examination certificate for the subsystem and the accompanying technical documentation as defined in the module SB,
 - evidence of conformity with other regulations deriving from the treaty (including certificates)
 - certificate of conformity of the notified body as mentioned under point 9, accompanied by corresponding verification and/or calculation notes and countersigned by itself, stating that the project complies with the Directive and the TSI, and mentioning, where appropriate, reservations recorded during performance of the activities and not withdrawn. The certificate should also be accompanied by the inspection and audit reports drawn up in connection with the verification, as mentioned in points 6.3 and 6.4 and in particular:
 - the rolling stock register, including all information as specified in the TSI.
11. Each notified body shall communicate to the other notified bodies the relevant information concerning the quality management system approvals issued, withdrawn or refused.

The other notified bodies may receive on request copies of the quality management system approvals issued.

12. The records accompanying the certificate of conformity shall be lodged with the contracting entity.

The contracting entity within the Community shall keep a copy of the technical file throughout the service life of the subsystem and for a further period of three years; it shall be sent to any other Member State which so requests.

To check with the requirement in the directive annex VI (the proposition modifies the directive)

F.3.3. Module SF: Product Verification

1. This module describes the EC verification procedure whereby a notified body checks and certifies at the request of an contracting entity or its authorised representative established within the Community, that a subsystem, for which a type-examination certificate has already been issued by a notified body,

- complies with this TSI and any other applicable TSI, which demonstrate that the essential requirements ⁽¹⁾ of Directive 2001/16/EC have been met
- complies with the other regulations deriving from the Treaty

and may be placed into service

⁽¹⁾ The essential requirements are reflected in the technical parameters, interfaces and performance requirements, which are set out in Chapter 4 of the TSI.

2. The contracting entity ⁽¹⁾ shall lodge an application for EC verification (through product verification) of the subsystem with a notified body of his choice.

The application shall include:

- The name and address of the contracting entity or its authorised representative
- the technical documentation.

3. Within that part of the procedure the contracting entity checks and attests that the subsystem concerned is in conformity with the type as described in the type examination certificate and satisfies the requirements of the TSI that apply to it.

The notified body shall carrying out the procedure under the condition that the type examination certificate issued prior to the assessment remains valid for the subsystem subject to the application.

4. The contracting entity shall take all measures necessary in order that the manufacturing process (including assembly and integration of interoperability constituents by main contractor ⁽²⁾ when employed) ensures conformity of the subsystem with the type as described in the type-examination certificate and with the requirements of the TSI that apply to it.

5. The application shall enable the design, manufacture, installation, maintenance and operation of the subsystem to be understood, and shall enable conformity with the type as described in the type-examination certificate and the requirements of the TSI to be assessed.

The application shall include:

- the technical documentation regarding the approved type, including the type examination certificate, as issued after completion of the procedure defined in module SB,

and, if not included in this documentation,

- a general description of the subsystem, overall design and structure,
- the rolling stock register, including all information as specified in the TSI,
- conceptual design and manufacturing information, for example drawings, schemes of components, sub-assemblies, assemblies, circuits, etc.,
- the technical documentation regarding the manufacture and the assembly of the subsystem,
- the technical specifications, including European specifications ⁽³⁾, that have been applied,
- any necessary supporting evidence for the use of the above specifications, in particular where these European specifications and the relevant clauses have not been applied in full,
- evidence of conformity to other regulations deriving from the treaty (including certificates) for the production phase
- a list of the Interoperability Constituents, to be incorporated into the subsystem,
- copies of the EC declarations of conformity or suitability for use with which said constituents shall be provided and all the necessary elements defined in annex VI of the directives,
- a list of manufacturers involved in the subsystem's design, manufacture, assembly and installation,

If the TSI requires further information for the technical documentation, this shall be included.

⁽¹⁾ In the module, 'the contracting entity' means 'the subsystem contracting entity, as defined in the directive, or his authorised representative established within the Community'.

⁽²⁾ The 'main contractor' refers to companies, whose activities contribute to fulfil essential requirements of the TSI. It concerns the company that can be responsible for the whole subsystem project or other companies only involved in a part of the subsystem project, (performing for example assembly or installation of the subsystem).

⁽³⁾ The definition of an European specification is indicated in the directives 96/48/EC and 2001/16/EC. The guide for application of HS TSIs explains the way to use the European Specifications

6. The notified body shall first examine the application concerning the validity of the type examination and the type examination certificate.

If the notified body considers the type examination certificate no longer remains valid or is not appropriate and that a new type examination is necessary, it shall justify its decision.

The notified body shall carry out the appropriate examinations and tests in order to check the conformity of the subsystem with the type, as described in the type examination certificate and with the requirements of the TSI. The notified body shall examine and testing of every subsystem manufactured as a serial product, as specified in point 4

7. Verification by examination and testing of every subsystem (as a serial product)
 - 7.1. The notified body shall carry out the tests, examinations and verifications, to ensure conformity of the subsystems, as serial products as provided for in the TSI. The examinations, tests and checking shall extend to the stages as provided for in the TSI.
 - 7.2. Each subsystem (as serial product) shall be individually examined, tested and verified ⁽¹⁾ in order to verify its conformity with the type as described in the type-examination certificate and the requirements of the TSI that apply to it. When a test is not set out in the TSI, (or in a European Standard quoted in the TSI), the relevant European Specifications or equivalent tests are applicable.
8. The notified body shall agree with the contracting entity (and the main contractor) the locations where the tests will be carried out and shall agree that final testing of the subsystem and, whenever required in the TSI, tests or validation under full operating conditions, are carried out by the contracting entity under direct supervision and attendance of the notified body.

The notified body shall have entrance for testing and verification purposes to production workshops, locations of assembly and installations, and where appropriate, prefabrication and testing facilities in order to carry out its tasks as provided for in the TSI.

9. Where the subsystem meets the requirements of the TSI, the notified body shall draw up the certificate of conformity intended for the contracting entity, which in turn draws up the EC declaration of verification intended for the supervisory authority in the Member State where the subsystem is located and/or operates.

These NB activities shall be based on the type examination and the tests, verifications and checks carried out on all serial products as indicated in point 7 and required in the TSI and/or in the relevant European specifications.

The EC declaration of verification and the accompanying documents shall be dated and signed. The declaration shall be written in the same language of the technical file and shall contain at least the information included in Annex V of the Directive.

10. The notified body shall be responsible for compiling the technical file that has to accompany the EC declaration of verification. The technical file shall include at least the information indicated in Art.18 (3) of the Directives, and in particular as follows:
 - all necessary documents relating to the characteristics of the subsystem
 - the rolling stock register, including all information as specified in the TSI,
 - the list of interoperability constituents incorporated into the subsystem,
 - copies of the EC declarations of conformity and, where appropriate, of the EC declarations of suitability for use, which the constituents shall be provided in accordance with Article 13 of the Directive, accompanied, where appropriate, by the corresponding documents (certificates, quality management system approvals and surveillance documents) issued by the notified bodies,
 - all elements relating to the maintenance, the conditions and limits for use of the subsystem,

⁽¹⁾ In particular, for the rolling stock TSI, the notified body will participate in the final in service testing of rolling stock or train set. This will be indicated in the relevant chapter of the TSI

- all elements relating to the instructions concerning servicing, constant or routine monitoring, adjustment and maintenance,
- the type-examination certificate for the subsystem and accompanying technical documentation, as defined in the module SB
- certificate of conformity of the notified body as mentioned in point 9, accompanied by corresponding calculation notes and countersigned by itself, stating that the project complies with the directive and the TSI, and mentioning, where appropriate, reservations recorded during performance of activities and not withdrawn. The certificate should also be accompanied, if relevant, by the inspection and audit reports drawn up in connection with the verification.

11. The records accompanying the certificate of conformity shall be lodged with the contracting entity.

The contracting entity shall keep a copy of the technical file throughout the service life of the subsystem and for a further period of three years; it shall be sent to any other Member State which so requests.

F.3.4. Module SH2: Full Quality Management System with Design Examination

1. This module describes the EC verification procedure whereby a notified body checks and certifies, at the request of an contracting entity or its authorised representative established within the Community, that a subsystem
- complies with this TSI and any other applicable TSI, which demonstrate that the essential requirements ⁽¹⁾ of Directive 2001/16/EC have been met
 - complies with the other regulations deriving from the Treaty.

and may be placed in service

2. The notified body shall carry out the procedure, including a design examination of the subsystem, under the condition, that the contracting entity ⁽²⁾ and the main contractor involved are satisfying the obligations of point. 3

The 'main contractor' refers to companies, whose activities contribute to fulfil the essential requirements of the TSI. It concerns the company:

- responsible for the whole subsystem project (including in particular responsibility for subsystem integration),
- other companies involved only in a part of the subsystem project (performing for example design, assembly or installation of the subsystem).

It does not refer to manufacturer sub contractors supplying components and interoperability constituents.

3. For the subsystem that is subject of the EC verification procedure, the contracting entity or the main contractor, when employed, shall operate an approved quality management system for design, manufacture and final product inspection and testing as specified in point 5 and which shall be subject to surveillance as specified in point 6

The main contractor responsible for the whole subsystem project (including in particular responsibility for subsystem integration), shall operate in any case an approved quality management system for design, manufacture and final product inspection and testing, which shall be subject to surveillance as specified in point 6.

In the case that the contracting entity itself is responsible for the whole subsystem project (including in particular responsibility for subsystem integration) or that the contracting entity is directly involved in the design and/or production (including assembly and installation), it shall operate an approved quality management system for those activities, which shall be subject to surveillance as specified in point 6.

Applicants which are only involved in assembly and installation, are permitted to operate only an approved quality management system for manufacture and final product inspection and testing

⁽¹⁾ The essential requirements are reflected in the technical parameters, interfaces and performance requirements, which are set out in Chapter 4 of the TSI.

⁽²⁾ In the module, 'the contracting entity' means 'the subsystem contracting entity, as defined in the directive, or his authorised representative established within the Community'.

4. EC verification procedure
- 4.1. The contracting entity shall lodge an application for EC verification of the subsystem (through full quality management system with design examination), including co ordination of surveillance of the quality management systems as in points 5.4. and 6.6., with a notified body of its choice. The contracting entity shall inform the manufacturers involved of his choice and of the application.
- 4.2. The application shall enable the design, manufacture, assembly, installation, maintenance and operation of the subsystem to be understood, and shall enable conformity with the requirements of the TSI to be assessed.

The application shall include:

- name and address of the contracting entity or its authorised representative,
- the technical documentation including:
 - a general description of the subsystem, overall design and structure,
- the technical design specifications, including European specifications ⁽¹⁾, that have been applied,
- any necessary supporting evidence for the use of the above specifications, in particular where the European specifications and the relevant clauses have not been applied in full.
- the test programme
- the rolling stock register, including all information as specified in the TSI,
- the technical documentation regarding the manufacture, the assembly of the subsystem,
 - a list of the interoperability constituents to be incorporated into the subsystem,
 - copies of the EC declarations of conformity or suitability for use with which the constituents shall be provided and all the necessary elements defined in annex VI of the directives,
 - evidence of conformity to other regulations deriving from the treaty (including certificates)
 - a list of all manufacturers, involved in the subsystem's design, manufacturing, assembly and installation,
 - conditions for use of the subsystem (restrictions of running time or distance, wear limits etc),
 - conditions for maintenance and technical documentation regarding the maintenance of the subsystem
 - any technical requirement that shall be taken into account during production, maintenance or operation of the subsystem
- the explanation, of how all stages, as mentioned in point 5.2, are covered by quality management systems of the main contractor and/or of the contracting entity, if involved, and the evidence of their effectiveness,
- indication of the notified body (ies) responsible for the approval and surveillance of these quality management systems.

⁽¹⁾ The definition of an European specification is indicated in the directives 96/48/EC and 2001/16/EC. The guide for application of HS TSIs explains the way to use the European Specifications

- 4.3. The contracting entity shall present the results of examinations, checking and tests ⁽¹⁾ including type tests when required, carried out by its appropriate laboratory or on their behalf.
- 4.4. The notified body shall examine the application concerning the design examination and assess the results of the tests. Where the design meets the provisions of the Directive and of the TSI that apply to it shall issue a design examination certificate to the applicant. The certificate shall contain the conclusions of the design examination, conditions for its validity, the necessary data for identification of the design examined and, if relevant, a description of the subsystem's functioning.

If the contracting entity is denied a design examination certificate, the notified body shall provide detailed reasons for such denial.

Provision shall be made for an appeals procedure.

- 4.5. During the production phase, the applicant shall inform the notified body that holds the technical documentation concerning the design examination certificate of all modifications which may affect the conformity with the requirements of the TSI or the prescribed conditions for use of the subsystem. The subsystem shall receive additional approval in such cases. In this case, the notified body shall perform only those examinations and tests, those are relevant and necessary to the changes. This additional approval may be given either in the form of an addition to the original design examination certificate, or by issue of a new certificate after withdrawal of the old certificate.

5. Quality management system

- 5.1. The contracting entity, if involved, and the main contractor, when employed, shall lodge an application for assessment of their quality management systems with a notified body of their choice.

The application shall include:

- all relevant information for the subsystem envisaged,
- the quality management system documentation.

For those only involved in a part of the subsystem project, the information to be provided is only that for the relevant part.

- 5.2. For the contracting entity or the main contractor responsible for the whole subsystem project, the quality management system shall ensure overall compliance of the subsystem with the requirements of the TSI.

The quality management system(s), for other contractors, has (have) to ensure compliance of their relevant contribution to the subsystem, with the requirements of the TSI.

All the elements, requirements and provisions adopted by the applicants shall be documented in a systematic and orderly manner in the form of written policies, procedures and instructions. This quality management system documentation shall ensure a common understanding of the quality policies and procedures such as quality programmes, plans, manuals and records.

The system shall contain in particular an adequate description of the following items:

- for all applicants:
 - the quality objectives and the organisational structure,
 - the corresponding manufacturing, quality control and quality management techniques, processes and systematic actions that will be used,
 - the examinations, checking and tests that will be carried out before, during and after design, manufacture, assembly and installation and the frequency with which they will be carried out,
 - the quality records, such as inspection reports and test data, calibration data, qualification reports of the personnel concerned, etc.,

⁽¹⁾ The presentation of the results of the tests can be at the same time as the application or later.

- for the main contractor, as far as relevant for its contribution to the design of the subsystem:
 - the technical design specifications, including European specifications that will be applied and, where the European specifications will not be applied in full, the means that will be used to ensure that the requirements of the TSI that apply to the subsystem will be met,
 - the design control and design verification techniques, processes and systematic actions that will be used when designing the subsystem,
 - the means to monitor the achievement of the required design and subsystem quality and the effective operation of the quality management systems in all phases including production.
- and also for the contracting entity or the main contractor responsible for the whole subsystem project:
 - responsibilities and powers of the management with regard to overall subsystem quality, including in particular the subsystem integration management.

The examinations, tests and checking shall cover all of the following stages:

- overall design,
- structure of the subsystem, including, in particular, civil-engineering activities, constituent assembly, final adjustment,
- final testing of the subsystem,
- and, where specified in the TSI, the validation under full operation conditions.

- 5.3. The notified body chosen by the contracting entity shall examine, if all stages of the subsystem as mentioned in point 5.2 are sufficiently and properly covered by the approval and surveillance of the quality management system(s) of the applicant(s) ⁽¹⁾.

If the compliance of the subsystem with the requirements of the TSI is based on more than one quality management system, the notified body shall examine in particular,

- if the relations and interfaces between the quality management systems are clearly documented

and if overall responsibilities and powers of the management for the compliance of the whole entire subsystem for the main contractor are sufficiently and properly defined.

- 5.4. The notified body referenced in point 5.1. shall assess the quality management system to determine whether it satisfies the requirements of point 5.2. It presumes compliance with these requirements if the applicant implements a quality system for design, production, final product inspection and testing in respect of the Standard EN/ISO 9001-2000, which takes into consideration the specificity of the subsystem for which it is implemented.

When an applicant operates a certified quality management system, the notified body shall take this into account in the assessment.

The audit shall be specific for the subsystem concerned, taking into consideration the specific contribution of the applicant to the subsystem. The auditing team shall have at least one member experienced as an assessor in the subsystem technology concerned. The evaluation procedure shall include an assessment visit to the applicant's premises.

The decision shall be notified to the applicant. The notification shall contain the conclusions of the examination and the reasoned assessment decision.

- 5.5. The contracting entity, if involved, and the main contractor shall undertake to fulfil the obligations arising out of the quality management system as approved and to uphold it so that it remains adequate and efficient.

⁽¹⁾ In particular, for the rolling stock TSI, the notified body will participate in the final in service testing of rolling stock or train set. This will be indicated in the relevant chapter of the TSI

They shall keep the notified body that has approved their quality management system informed of any significant change that will affect the fulfilment of the requirements by the subsystem.

The notified body shall evaluate any modifications proposed and decide whether the amended quality management system will still satisfy the requirements of point 5.2 or whether a re-assessment is required.

It shall notify its decision to the applicant. The notification shall contain the conclusions of the examination and the reasoned assessment decision.

6. Surveillance of the quality management system(s) under the responsibility of the notified body
 - 6.1. The purpose of surveillance is to make sure that the contracting entity, if involved, and the main contractor duly fulfil the obligations arising out of the approved quality management system(s).
 - 6.2. The contracting entity, if involved, and the main contractor shall send the notified body referenced in point 5.1. (or have sent) all the documents needed for that purpose and in particular the implementation plans and technical records concerning the subsystem (as far as relevant for the specific contribution of the applicant to the subsystem), including:
 - the quality management system documentation, including the particular means implemented to ensure that
 - for the contracting entity or the main contractor, responsible for the whole subsystem project,
 - overall responsibilities and powers of the management for the compliance of the whole entire subsystem are sufficiently and properly defined,
 - for each applicant,
 - the quality management system is correctly managed for achieving integration at subsystem level,
 - the quality records as foreseen by the design part of the quality management system, such as results of analyses, calculations, tests, etc.,
 - the quality records as foreseen by the manufacturing part (including assembly, installation and integration) of the quality management system, such as inspection reports and test data, calibration data, competency records of the personnel concerned, etc.
 - 6.3. The notified body shall periodically carry out audits to make sure that the contracting entity, if involved, and the main contractor maintain and apply the quality management system and shall provide an audit report to them. When they operate a certified quality management system, the notified body shall take this into account in the surveillance.

The frequency of the audits shall be at least once a year, with at least one audit during the time period of performing the relevant activities (design, manufacture, assembly or installation) for the subsystem being the subject of the EC verification procedure mentioned in point 4.
 - 6.4. Additionally the notified body may pay unexpected visits to the sites mentioned in point 5.2 of the applicant(s). At the time of such visits, the notified body may conduct complete or partial audits and may carry out or cause to be carried out tests in order to check the proper functioning of the quality management system where necessary. It shall provide the applicant(s) with an inspection report and audit and/or test reports as appropriate.
 - 6.5. The notified body chosen by the contracting entity and responsible for the EC verification, if not carrying out the surveillance of all the quality management system(s) concerned as under point 5, shall co ordinate the surveillance activities of any other notified bodies responsible for that task, in order:
 - to be ensured that correct management of interfaces between the different quality management systems relating to subsystem integration has been performed.

- to collect, in liaison with the contracting entity, the necessary elements for the assessment to guarantee the consistency and the overall supervision of the different quality management systems.

This co ordination includes the right of the notified body

- to receive all documentation (approval and surveillance), issued by the other notified body(s),
 - to witness the surveillance audits as in point 5.4.,
 - to initiate additional audits as in point 5.5. under its responsibility and together with the other notified body(s).
7. The notified body as referenced under point 5.1. shall have entrance for inspection purposes, audit and surveillance to the locations of design, building sites, production workshops, locations of assembly and installation, storage areas and, where appropriate, prefabrication or testing facilities and, more general, to all premises which it considers necessary for its task, in accordance with the applicant's specific contribution to the sub-system project.
8. The contracting entity, if involved, and the main contractor shall, for a period of 10 years after the last sub-system has been manufactured, keep at the disposal of the national authorities:
- the documentation referenced in the second indent of the second subparagraph of point 5.1,
 - the updating referenced in the second subparagraph of point 5.5,
 - the decisions and reports from the notified body which are referenced in the points 5.4, 5.5 and 6.4
9. Where the subsystem meets the requirements of the TSI, the notified body shall then, based on the design examination and the approval and surveillance of the quality management system (s), draw up the certificate of conformity intended for the contracting entity, who shall in turn draw up the EC declaration of verification intended for the supervisory authority in the Member State within which the subsystem is located and/or operates.

The EC declaration of verification and the accompanying documents shall be dated and signed. The declaration shall be written in the same language of the technical file and shall contain at least the information included in Annex V of the Directive.

10. The notified body chosen by the contracting entity shall be responsible for compiling the technical file that has to accompany the EC declaration of verification. The technical file shall include at least the information indicated in Art 18 (3) of The Directive, and in particular as follows:
- all necessary documents relating to the characteristics of the subsystem
 - the list of interoperability constituents incorporated into the subsystem,
 - copies of the EC declarations of conformity and, where appropriate, of the EC declarations of suitability for use, which the constituents shall be provided in accordance with Article 13 of the Directive, accompanied, where appropriate, by the corresponding documents (certificates, quality management system approvals and surveillance documents) issued by the notified bodies,
 - evidence of conformity to other regulations deriving from the treaty (including certificates)
 - all elements relating to the maintenance, the conditions and limits for use of the subsystem,
 - all elements relating to the instructions concerning servicing, constant or routine monitoring, adjustment and maintenance

- certificate of conformity of the notified body as mentioned under point 9, accompanied by corresponding verification and/or calculation notes and countersigned by itself, stating that the project complies with the Directive and the TSI, and mentioning, where appropriate, reservations recorded during performance of the activities and not withdrawn.

The certificate should also be accompanied, if relevant, by the inspection and audit reports drawn up in connection with the verification, as mentioned in points 6.4. and 6.5.;

- the rolling stock register, including all information as specified in the TSI.

11. Each notified body shall communicate to the other notified bodies the relevant information concerning the quality management system approvals and the EC design examination certificates, which it has issued, withdrawn or refused.

The other notified bodies may receive on request copies of:

- the quality management system approvals and additional approvals issued and
- the EC design examination certificates and additions issued

12. The records accompanying the certificate of conformity shall be lodged with the contracting entity

The contracting entity shall keep a copy of the technical file throughout the service life of the subsystem and for a further period of three years; it shall be sent to any other Member State which so requests.

F.4. **Assessment of Maintenance Arrangements: Conformity Assessment Procedure**

This is an open point.

ANNEX G

Effects of Crosswinds**G.1. General remarks**

This annex defines the approach for assessing the crosswind stability of Class 1 trains according to the TSI definition.

Tilting trains are not dealt with explicitly in the present document. However, tilting trains running at conventional cant deficiencies in a non-tilting mode may be treated as non-tilting trains. Tilting trains running at conventional cant deficiencies with tilting mechanism on will be characterised in tilting car body position.

G.2. Introduction

The general idea about the methodology is that:

- the cross wind stability of a train can be assessed using *Characteristic Wind Curves*
- the crosswind characteristics of a line and its operation can be assessed by considering the crosswind risk that a certain well-defined reference train will experience when operating on that line.

If a train does not fulfil these general requirements it is still permitted to prove its crosswind safety on a specific line.

G.3. General principles

The critical event under consideration is train overturning. Interoperable trains shall have a basic level of safety against this critical event. The train contribution to the safety level is defined by a set of *Characteristic Reference Wind Curves* (CRWC). A train can be regarded as interoperable from the crosswind point of view if its *Characteristic Wind Curves* (CWC) are at least as good as the CRWC.

A particular train is defined by its most critical vehicle. Usually, this vehicle is one of the two leading or end vehicles. If another vehicle in the train is considered to be more wind sensitive (e.g. a very high or light vehicle), it has to be considered. The choice of the most sensitive vehicle shall be fully justified.

For a given train running at a range of speeds, the CWC define the maximum natural wind speed that a train can withstand before a characteristic limit for wheel unloading is exceeded. The criterion that defines the CWC is the average value of wheel unloading, ΔQ , of the most critical running gear. The term 'average' means that, in case of bogies, wheel unloading is averaged over the two wheelsets of the bogie.

G.4. Range of application

The operational mode of the high-speed trains is considered for non-tilting trains and for tilting trains in non-tilting mode when they are running with a cant deficiency as set out in High Speed Infrastructure TSI 2006.

It is assumed that the train runs under European operational and wind conditions.

G.5. Assessment of Characteristic Wind Curves**G.5.1. Aerodynamic properties determination****G.5.1.1. General remarks**

Currently only wind tunnel tests are considered capable of giving sufficiently reliable train aerodynamic properties.

Aerodynamic properties shall be determined for both a flat ground and an embankment configuration consisting of a 6m reference embankment.

One reference vehicle, namely the ICE3 or the TGV Duplex or the ETR500 front vehicles, followed by the relevant second vehicle, shall have been tested and measured the same way in the same wind tunnel when a new vehicle is investigated.

The definition of the aerodynamic coordinate system and the aerodynamic coefficients shall be consistent with EN14067-1:2003.

G.5.1.2. Wind tunnel test requirements

The dimensions of the wind tunnel shall be as large as possible so as to avoid boundary interference effects, (e.g. from the walls, the boundary layer of the roof and the ground) and wind tunnel blockage effects. In particular, when investigating the aerodynamic forces and moments on the embankment, blockage effects shall be considered.

G.5.1.2.1. Test section dimensions

For yaw angles up to 30°, the blockage shall not exceed 10 %, even when an embankment is present.

For wind tunnels with a closed test section, blockage corrections are advised for blockage ratios exceeding 5 %.

For wind tunnels with open or partially open test section, the blockage ratio shall be smaller than 5 % at a yaw angle of 30° and no corrections are to be applied.

G.5.1.2.2. Turbulence level

The atmospheric turbulence layer shall not be represented in the wind tunnel tests. It is necessary to ensure turbulence level $Tu_x \leq 2,5 \%$, where $Tu_x = \left(\frac{i^2}{\bar{u}^2} \right)^{0,5}$ with u denoting the stream wise velocity component.

G.5.1.2.3. Boundary layer

The wind tunnel velocity profile shall be a uniform, i.e. block, profile. The flow speed shall be independent of the height above ground, except for a thin boundary layer on the wind tunnel floor. The thickness of the boundary layer, $\delta_{95\%}$, shall be small relative to the height of the vehicle.

G.5.1.2.4. Reynolds' number

The Reynolds' number based on the wind tunnel speed, the characteristic length of 3 m (divided by the model scale) should exceed the critical value above which the forces and moments do not change significantly with increasing Reynolds' number. This shall be demonstrated by test results.

The Mach number shall be no higher than 0,3. If the real train operates at Mach numbers higher than 0,3, the Mach number shall not be higher than the Mach number of the real train.

G.5.1.2.5. Instrumentation

The density of the air in the wind tunnel and its temperature, pressure and humidity shall be determined.

The aerodynamic forces and aerodynamic moments have to be determined using a five component dynamometer balance, (C_{Fx} is not needed) The sensitivity and the mounting of the balance shall be in accordance with the range of loads measured

G.5.1.3. Model requirements

The dimensional accuracy of the model shall be better than 10 mm with respect to the full-scale dimensions. All essential details of aerodynamic importance, such as the front windshield or the pantograph cut out shall be replicated true to scale.

The pantograph itself shall not be modelled.

A simplification of the bogies is allowed; only the basic geometrical properties of the bogies shall be represented in order to ensure the correct mass flux and the pressure drop in the underbelly flow regime.

The model should be symmetrical, even if the real train is not build perfectly symmetrically (e.g. due to details in the under floor region). This permits a symmetry check to be made in the wind tunnel to investigate sources of error in the measurement due to flow asymmetries.

G.5.1.4. Test programme requirements

Symmetry and repeatability checks shall be performed to ensure the validity of results.

Yaw angles

Yaw angles between 0° and 70°, in steps of 5°, shall be considered.

A linear or higher order interpolation shall be used for all intermediate yaw angles.

Upstream and downstream bodies

For all vehicles under investigation a down-stream body of at least half the vehicle length has to be placed next to model. The true cross section shall be represented at least for one-third of a vehicle length; the trailing edge of this body shall be streamlined.

If the vehicle under investigation is not a leading vehicle, at least one full vehicle ahead need to be present to ensure realistic upstream flow conditions. The true intercar-gap between the vehicles has to be represented. Mechanical contact between the tested model and the passive bodies shall be excluded at all times. Vibration of the model and adjacent passive bodies shall be avoided.

Ground Configurations

Until the ground configurations are clearly defined in a European standard, the following shall be applied:

Measurements shall be conducted for two scenarios:

- a flat ground scenario

The flat ground configuration shall not incorporate a representation of the ballast bed and rails. The clearance between the ground level and the bottom of the wheels is 235 mm based on full scale.

- and for a standardised embankment scenario:

- The embankment case refers to a standard 6m embankment with a slope of 2:3 and a base width of 32 m at full scale, Figure G.3. On top of the embankment there shall be two tracks with the dimensions shown in Figure G.2. Alternatively, a configuration with ballast and rails on flat ground may be used, as shown in Figure G.2, with a transformation applied to determine the force and moments for a 6 m. embankment configuration as outlined in clause G.6. For train speeds below 200 km/h (and angles β above 40°) tests shall be carried out for the windward and leeward configurations.

- For train speeds of 200 km/h and higher only the windward configurations has to be considered. Thus, in this speed range, a single track embankment with reduced base width is allowed.

The $C_{m,x,lee}$ aerodynamic coefficient for relevant yaw angles obtained from the test on the reference vehicle should confirm the quality within 10 % for flat ground and 20 % for embankment case.

Figure G.2.

Ballast and rail.

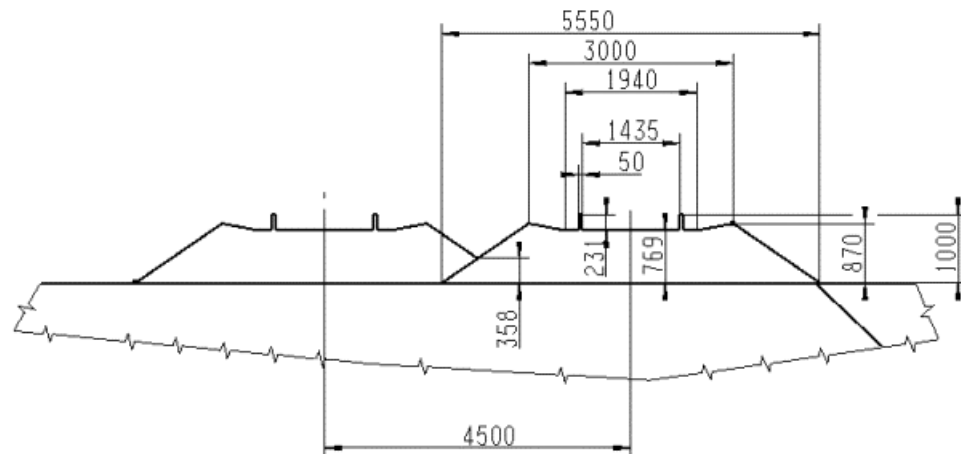
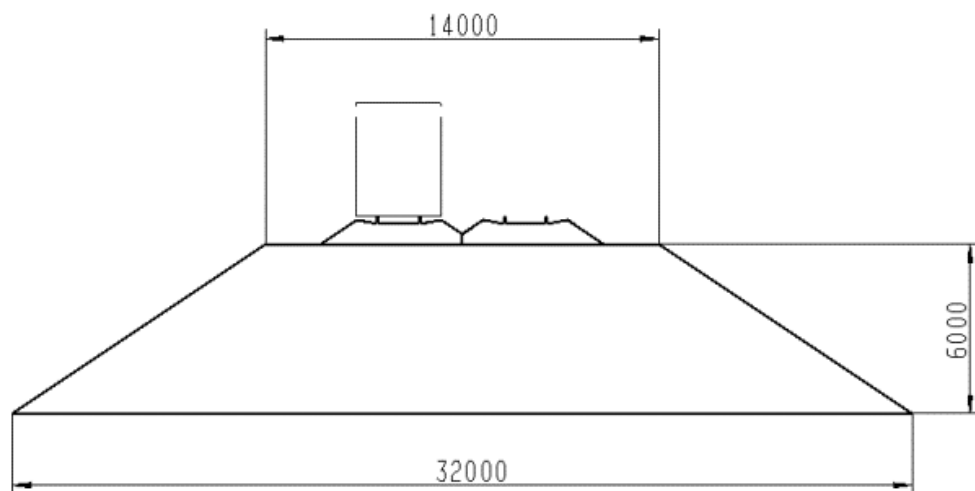

Figure G.3.

Standard 6 m embankment.



G.5.2. Description of the Wind Scenario

The gust generated for the method corresponds to a fixed amplitude (corresponding to a probability level of amplitude ~99 %) and a probability level exceeding 50 % for the gust duration (the mode of the distribution). Furthermore, the chosen approach has the following characteristics:

- The gust time-space model (bi-exponential) is based on a gust model investigated in Deufrako and corresponds to the best approximation of a random process in the vicinity of a local maximum.
- The mean wind is assumed to be horizontal (only the longitudinal component U is used). This component represents the prominent part of wind fluctuations and is the projection of the instantaneous wind vector in the mean wind direction.

- Variations of wind direction are not taken into account.
- Temporal variations are neglected in favour of spatial variations.

The input data for the scenario are:

- V_{tr} train speed,
- U_{max} maximum wind speed,
- γ wind direction with respect to the line.

The following parameters are fixed:

- $z = 4$ m reference height,
- $\tilde{A} = 2,84$ normalized gust amplitude $\tilde{A} = (U_{max} - U)/\sigma_u$ with mean wind speed U ,
- $z_0 = 0,07$ m roughness length of sites representative of interoperable lines,
- $Pr(T) = 0,5$ probability of a gust of duration T for a given amplitude A .

G.5.3. Calculation of the turbulence characteristics

G.5.3.1. Turbulence Intensity

At a site of height $z = 4$ m, the turbulence intensity I equals 0,245. The gust factor is calculated from the turbulence intensity and the normalised gust amplitude:

$$G = 1 + \tilde{A} \cdot I = 1,6946.$$

A fixed value of the normalised amplitude, hence of the gust factor is chosen. In special areas, or for specific applications, different values for \tilde{A} could be chosen from meteorological measurement analysis.

From the gust factor the mean wind U_{mean} can be deduced from a given maximum wind U_{max} :

$$U_{mean} = \frac{U_{max}}{G} = \frac{U_{max}}{1,6946}.$$

The standard deviation of longitudinal component (following the mean wind speed) of the wind σ_u is then deduced from the mean wind speed and the turbulence intensity:

$$\sigma_u = I \cdot U_{mean} = I \cdot \frac{U_{max}}{G} = 0,1443 U_{max}.$$

G.5.3.2. Gust Duration

The calculation of the gust time constants is derived from the spectral characteristics (PSD) of the longitudinal characteristic length L_u^x (i.e. following the gust, x-direction, u-component)

$$L_u^x = 50 \cdot \frac{z^{0,35}}{z_0^{0,063}}$$

The mean duration of gusts, \bar{T} , is given by the following integral quotient

$$\bar{T} = \frac{1}{2} \cdot \frac{\left[\int_{n_1}^{n_2} n^2 \cdot S_u(n) dn \right]}{\left[\int_{n_1}^{n_2} S_u(n) dn \right]}^{-\frac{1}{2}},$$

Where the power spectral density (PSD) of turbulence $\bar{S}_u(n)$ is given by the *Von Karman* expression:

$$\bar{S}_u(n) = \frac{4 \cdot f_u \cdot \sigma_u^2}{(1 + 70,7 \cdot f_u^2)^{\frac{5}{6}}} \cdot \frac{1}{n} \text{ where}$$

$$f_u = \frac{n \cdot L_u^x}{U_{\text{mean}}} \text{ is the normalised frequency and}$$

n the frequency ranging from minimal(n_1) to maximal(n_2) values. These values n_1 and n_2 are the limit values for the gust frequency spectrum integration. The lower frequency n_1 is taken as 1/300 Hz and the upper frequency n_2 is taken as 1 Hz.

The duration of the maximum gust is then given by:

$$Y = \bar{T} \cdot 0,95 \cdot \tilde{A}^q = 4,182 \cdot \bar{T},$$

where the exponent q was given by measurements and is taken as 1,42).

G.5.3.3. Derivation of the resulting time history of the gust

From knowledge of the time constants, the time history of the non-dimensional wind variations in the longitudinal and lateral directions following the mean wind direction can be derived. Then the non-dimensional wind speed variations of the component u in the longitudinal direction a_x and lateral direction a_y can be written at a distance s of the maximum of the gust as:

$$a_x(s) = \frac{1}{2} \cdot s \cdot \cos(D) \cdot \frac{1}{T \cdot U_{\text{mean}}}$$

$$a_y(s) = \frac{1}{2} \cdot s \cdot \sin(D) \cdot \frac{1}{T \cdot U_{\text{mean}}}$$

with s being the coordinate following the track in $s = V_{\text{tr}} \cdot (t - t_{\text{max}})$, t_{max} is the time of the maximum gust impact on the train, and D is the angle between track and wind direction.

From the coherence decay and exponent coefficient of the gust parallel and perpendicular to the mean wind speed a correlation function at an instant t can be calculated as:

$$C(t) = e^{-\sqrt{(C_u^x \cdot u_x^{p_x})^2 + (C_u^y \cdot u_y^{p_y})^2}}$$

with

$C(t)$ being the correlation function between the amplitude of the gust at instant t and the maximum amplitude of gust;

C_u^x is the coherence decay coefficient in the mean wind direction (parameter value: 5,0);

C_u^y is the coherence decay coefficient perpendicular to the mean wind direction (parameter value: 16,0);

p_u^x is the exponent coefficient in the mean wind direction (parameter value: 1,0)

p_u^y is the exponent coefficient perpendicular to the mean wind direction (parameter value: 1,0).

All the parameters values are based on measurements.

The wind speed impacting on the train can then be written from the following formula

$$v_{\text{wind}}(t) = U_{\text{mean}} + \tilde{A} \cdot \sigma_u \cdot C(t).$$

For the wind scenario the following time-history has to be considered (the time of the maximum gust is $t_3 = 14$ sec):

From $t = 0$ to $t = t_1 = 0,5$ s: $v_{\text{wind}}(t) = 0$;

From $t = t_1 = 0,5$ s to $t = t_2 = 3$ s: linear increase of v_{wind} to reach U_{mean} at $t = t_2 = 3$ s;

From $t = t_2 = 3$ s to $t = t_3 = 10$ s: $v_{\text{wind}}(t) = U_{\text{mean}}$;

From $t = t_3 = 10$ s to $t = t_4 = 14$ s: $v_{\text{wind}}(t) = U_{\text{mean}} + \tilde{\Lambda} \cdot \sigma_u \cdot C(t)$;

From $t = t_4 = 14$ s to $t = t_5 = 17$ s: $v_{\text{wind}}(t) = U_{\text{mean}} + \tilde{\Lambda} \cdot \sigma_u \cdot C(t)$;

From $t = t_5 = 17$ s to $t = t_6 = 30$ sec $v_{\text{wind}}(t) = U_{\text{mean}}$.

The time-history of the wind speed is illustrated in Figure G.1.

Figure G.1.

Illustration of time-history for the wind speed.

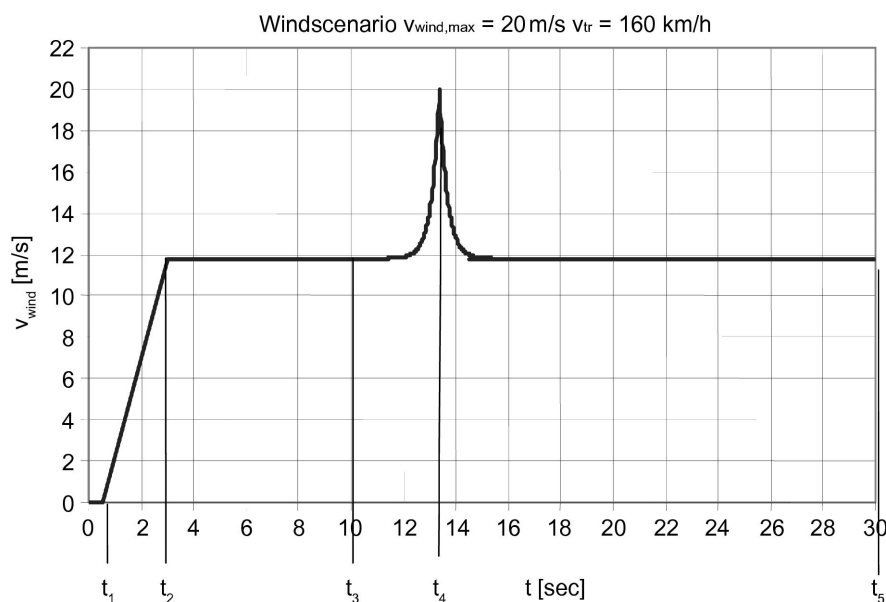

Remark: This gust scenario is not appropriate for fully articulated trainsets. For such trainsets an alternative gust scenario shall be developed.

The spatial wind scenario shall be filtered with a spatial-average filter based on a window size equal to the vehicle length and a step size smaller than 0,5 m.

G.5.4. Vehicle dynamics determination

G.5.4.1. General remarks

Multibody simulations (MBS) shall be used to determine the vehicle dynamic behaviour under strong wind.

A general-purpose, validated MBS program shall be used along with a gust scenario. Modelling shall consider the most critical vehicle of the train and that this vehicle is empty and in running order. A check shall be made that an even distribution of passenger is not more critical than an empty vehicle (for instance due to centre of gravity shifts), e.g. by using a simplified check with a fully static approach.

If there is no roll restraint at the coupling, only the critical vehicle needs to be modelled, otherwise adjacent vehicles shall be modelled too.

Track irregularities shall not be considered.

The calculation shall be carried out with standard gauge, UIC60 rail profile, new wheel profile and 1/20 and 1/40 rail inclinations. The worst case will be used for assessment against the limits.

The aerodynamic forces and moments shall be included.

The criterion that defines the CWC is the average value of wheel unloading, ΔQ , of the most critical running gear (bogie or single axle in case of single axle running gear). This unloading shall not exceed 90 % of the static axle loads, Q_0 , of the running gear as given in the following formula:

$$\frac{\Delta Q}{Q_0} < 0,9.$$

G.5.4.2. Modelling

The modelling of the vehicle shall be adequate for the investigation of cross wind characteristics. The dynamic model of the vehicle shall be 3D.

The dynamic model of the vehicle shall incorporate at least the following features:

- Car-body, bogies and wheelsets and other relevant parts of the vehicle (masses, inertias, geometry and centres of gravity).
- Suspensions (stiffness of the springs in the vertical, lateral and longitudinal directions, non-linearity in stiffness, damping characteristics in the vertical and lateral directions, damping non-linearity),
- Bump stops which could come into play.
- Wheel/rail contact (nominal wheel and rail profiles as defined by the High-Speed TSI, contact forces calculated featuring nonlinear contact geometry and creep force/creep relation. Any special further device in the suspension system which might have an effect on the overturning mechanism.

G.5.4.3. Verification of the Vehicle Model

A verification of the MBS model, based on full-scale test data, shall be provided. It is essential to compare the suspension coefficient and the masses and centres of gravities between the simulation and the test cases, both with the empty (unloaded) vehicle.

The definition of the suspension coefficient 's' shall comply with clause 4.2.3.9 of this TSI. If more than one value for s is available from test, the average shall be taken. The difference between the simulation and the test shall not exceed 10 %.

The correctness of the modelling of the bump stops shall be proven. The simulation results regarding displacements to the stops shall meet with the design data.

The total mass of the vehicle is measured as the sum of all vertical Q_0 forces. The averaged measured mass of the first two production vehicles shall not be less than 99 % of the vehicle mass used in the simulation. Furthermore the measured individual axle load, averaged on the first two production vehicles, shall not be less than 99 % of the individual axle loads used in the simulation.

When information is available, the following test results shall be evaluated:

- Transient records of Q-forces at each wheel of the leading two wheel sets for different curve radius classes (according to clause 5 of EN14363:2005) when running with cant deficiency.
- Extended data processing ('two-dimensional' evaluation) for the 50 % values of the Q-forces as given in clause 5.5 EN14363:2005.

G.6. Aerodynamic Forces and Moments as Inputs for the Multi-Body Simulation

For each case defined in section G.7.4, different calculations of the vehicle responses to gusts defined by their maximum speed U_{\max} shall be computed for increasing values of U_{\max} until the criteria defined in section G.7.1 are met. The corresponding plots of U_{\max} values meeting the maximum unloading criteria against the vehicle speed and/or wind angle are called characteristic wind curves (CWC). The presentation of CWC is described in detail in section G.7.4.

The simulation of the vehicle response to a gust shall be performed using the gust scenario described in section G.5.

For both flat ground and embankment configurations, the five components of forces and moments (F_y , F_z , M_x , M_y and M_z) shall be calculated using the following formulae:

$$\left. \begin{aligned} F_i(t) &= \frac{1}{2} \rho S C_{Fi}(\beta(t)) V_r^2(t) \\ M_i(t) &= \frac{1}{2} \rho S l C_{Mi}(\beta(t)) V_r^2(t) \end{aligned} \right\} , i \in \{x, y, z\},$$

$$\left. \begin{aligned} V_r(t) &= \sqrt{(V_T + U(t) \cos \gamma)^2 + C(t)^2 (U(t) \sin \gamma)^2} \\ \text{and } \beta(t) &= \text{Arc tan} \left(\frac{C(t) U(t) \sin \gamma}{V_T + U(t) \cos \gamma} \right) \\ C(t) &= \frac{C_{SV} - 1 + G(t)}{C_{SV} G(t)} \end{aligned} \right\} \text{ for the embankment configuration}$$

where

— $U(t)$ is the upstream wind speed.

— $C_{SV} = 1,2416$ for the windward case

and

— $C_{SV} = 1,1705$ for the leeward case. For the flat ground configuration $C(t) = 1,0$.

$G(t)$ is the instantaneous gust factor calculated by dividing the instantaneous wind speed of the Chinese hat by the mean speed.

The density employed for the calculation of aerodynamic forces and moments is $\rho = 1,225 \text{ kg/m}^3$

The simulation is done without any track irregularities.

It shall be proven that the integration method calculates an integration step at the maximum wind peak. The output step size of the calculation shall be lower than 1/30s.

G.7. Calculation and Representation of Characteristic Wind Curves

G.7.1. Evaluation of the Criterion

From each simulation run of the parameter variation time data of the Q-forces for each wheel are obtained.

The following calculation steps are needed:

- Calculation of the $\Delta Q/Q_0$ values by the time-data of Q-forces

$$\frac{\Delta Q}{Q_0} = 1 - \frac{Q_{i1} + Q_{j1}}{2 \cdot Q_0}$$

- Low-pass filtering of $\Delta Q/Q_0$ with a 2 Hz 4th order Butterworth filter, or another filter shown to be equivalent.
- Identify the maximum $\Delta Q/Q_0$ value over the running gear.

Herein Q_0 are the Q-forces for the empty (unloaded) vehicle without any excitation, Q_{i1} are the Q-forces of the unloaded wheel of the first wheel set in the bogie and Q_{j1} are the Q-forces of the unloaded wheel of the second wheel set in the bogie.

G.7.2. Calculation of the Wind Values and Limiting Values for $\Delta Q/Q_0$

For curved track the centrifugal force acts in addition to the crosswind on the vehicle.

The calculation shall be performed using MBS on straight track, canted according to a_q values.

G.7.3. Considering Different Wind Angles

The computed characteristic wind velocities can be transferred to other combinations of train speeds and angles.

Usually the characteristic wind velocity is given for a wind angle of 90° to the track. To obtain the CWC for other angles, a geometric decomposition/addition of the velocity vectors has to be carried out first (see Figure G.4).

Figure G.4.

Geometric approach considering the angle of attack.

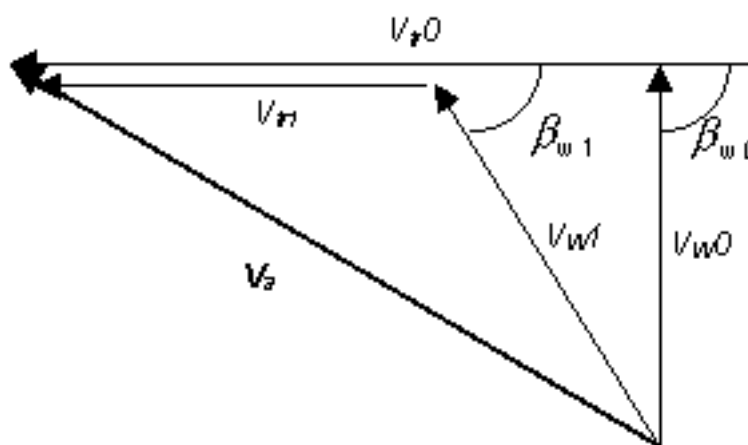

Here, v_a is the wind acting on the vehicle. A decomposition of v_a into a component coming from the train speed (v_{tr0} and v_{tr1}) and a component coming from the wind speed (v_{w0} and v_{w1}) can be made in various ways. For the vector chain v_{w0} and v_{tr0} the wind angle is β_{w0} , and for the vector chain v_{w1} and v_{tr1} the wind angle is β_{w1} . Then, for the new triple (v_{tr} , v_w , β_w) the characteristic wind velocity can be derived from the CWC, originally based on another triple v_{tr} , v_w , β_w . For straight track, the wind velocity for different angles of attack can be directly drawn out in a diagram. An example is illustrated in the Figure G.5.

Figure G.5.

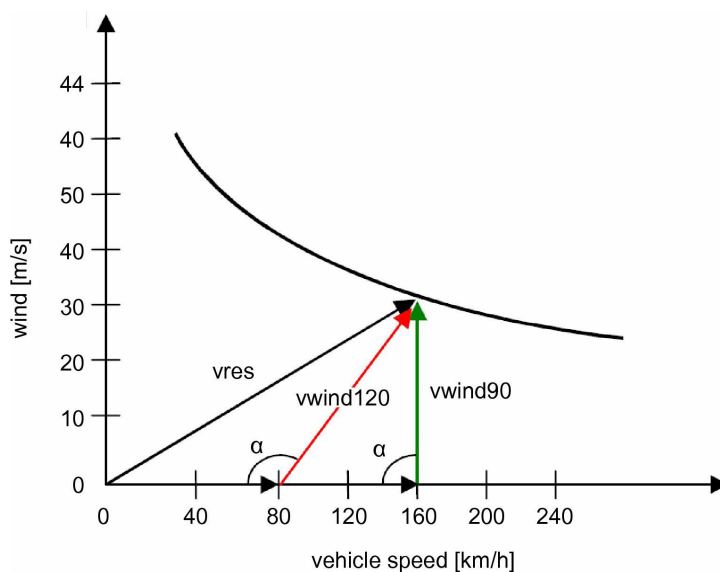
Geometric approach to consider the angle of attack of CWC on straight track.**G.7.4. Representation of Wind Characteristics by Distinct Points**

The characteristic wind curves are based on the following points. For these points the characteristic wind speeds shall be computed.

G.7.4.1. Vehicle on straight track

For a wind angle to the track of $\beta_w = 90^\circ$ the characteristic wind speeds have to be computed for the train speeds $v_{tr} = 120$ km/h; 160 km/h; 200 km/h; 250 km/h; 300 km/h; $v_{tr,max}$ for both the flat ground and the embankment configuration.

In addition, for the maximum train operating speed, the characteristic wind speeds shall be computed for the angles $\beta_w = 80^\circ$; 70° ; 60° ; 50° ; 40° ; 30° ; 20° for both flat ground and embankment configurations. For the embankment configuration an additional computation at $\beta_w = 10^\circ$ is needed.

G.7.4.2. Vehicle in a curve

To account for the vehicle running in curves the values $\Delta Q/Q_{0,curve}$ for the flat ground configuration shall be computed for $a_q = 0,5$ m/s² and 1 m/s² at train speeds of $v_{tr} = 250$ km/h, $v_{tr} = 300$ km/h and $v_{tr} = v_{tr,max}$, with unfavourable conditions for a_q .

G.8. Required Documentation

The determination and assessment of the CWC require detailed documentation, which indicates and explains the underlying parameters, the assumptions made and the conclusions drawn. The major steps when processing and assessing the CWC, as well as the conformity to annex G, shall be clearly demonstrated.

As a result the following documents shall be provided:

- Test Report of Wind Tunnel Tests (cf. to chapter G.3),
- Test Report of Running Tests according to clause 5.6 of EN14363:2004 for the model verification,
- Report for the Modelling of the Vehicle Dynamics with Verification (see chapter G.5),
- Report about the Processing of the Characteristic Wind Curves (see chapter G.6 & G.7),
- Summary Report with Assessment of Characteristic Wind Curves (see chapter G.8),

ANNEX H

Front and rear lamps**H.1. Definitions****Headlamp**

a white light on the front end of a train, intended to provide visual warning of an approaching train, and to illuminate lineside signs.

Marker lamp

a white light on the front end of a train, intended to indicate the presence of a train.

Tail lamp

a red light on the rear end of a train, intended to indicate the presence of a train.

Combined lamp

Combined lamps (e.g. lamps capable of different functions) shall be permitted only where the requirements for the individual lamp functions are achieved.

CIE(1931) standard colourimetric system (x, y, z)

A system for specifying colour by determining the tristimulus values of the spectral power distribution of a coloured light using the set of reference colour stimuli [X], [Y], [Z] and the three CIE colour matching functions $x(\lambda)$, $y(\lambda)$, $z(\lambda)$, adopted by the CIE in 1931 (See CIE Publication No. 15.2-1986).

H.2. Front Lamps**(a) Headlamps**

Each headlamp shall provide a source of white light 170mm in diameter. It is permissible to use non-circular headlamps in which case the minimum lit area shall be 22 000 mm² with a minimum dimension of 110 mm.

Photometric requirements

The luminous intensities of headlamps, measured along the centre line of the headlamp, shall be as shown in Tables H1.

The required luminous intensities shall be reached when installed on the vehicle.

*Table H1.***Luminous intensities for headlamps**

	Dimmed head lamp	Full-beam head lamp
Luminous intensity (cd) along centre line	12 000-16 000	> 40 000
Luminous intensity (cd) at all angles within 5° on either side of the centre line in the horizontal plane	> 3 000	> 10 000

Assessment is defined in clause H.4 section (b).

(b) Marker Lamps

Each marker lamp shall provide a source of white light at least 170 mm in diameter. It is permissible to use non-circular marker lamps in which case the minimum lit area shall be 22 000 mm² with a minimum dimension of 110 mm.

Photometric requirements

The luminous intensities of marker lamps, measured along the centre line of the marker lamp, shall be as shown in Tables H2 and H3 below.

Table H2.

Luminous Intensities for Lower Marker Lamps

	Dimmed lower marker lamp	Full lower marker lamp
Luminous intensity (cd) along centre line	Minimum 100	300-700
Luminous intensity (cd) at 45° on either side of the centre line in the horizontal plane	20-40	

Table H3.

Luminous Intensities for Upper Marker Lamps

	Dimmed upper marker lamp	Full upper marker lamp
Luminous intensity along the centre line (cd)	Minimum 50	150-350

Assessment is defined in clause H.4 section (b).

(c) Colourimetric and Spectral requirements

The colour of light emitted by head and marker lamps shall comply with the requirements of CIE S004/E-2001, as shown in table H4:

Table H4.

Colour range intersection points

Colour of light	CIE(1931) colour coordinates of the intersection points				
	Intersection point	I	J	K	L
White Class A	x	0,300	0,440	0,440	0,300
	y	0,342	0,432	0,382	0,276

Assessment is defined in clause H.4 section (a).

Spectral radiation distribution of light

The spectral radiation distribution of the light used is substantially responsible for the colour recognition of signs. All illuminants shall ensure that there are no significant distortion of colour in colour recognition of signs and other objects.

In order to demonstrate compliance with this requirement, a ratio k_{colour} shall apply between the entire visible light range and the individual spectral colour ranges to be considered.

The ratio k_{colour} shall be determined according to the equation below:

$$k_{\text{colour}} = \frac{\int_{\lambda_{\text{colour}}} S(\lambda) \cdot V(\lambda) \cdot d\lambda}{\int_{\lambda_{\text{total}}} S(\lambda) \cdot V(\lambda) \cdot d\lambda}$$

- $S(\lambda)$ – spectral energy distribution (by spectral measurement) as the spectral radiance in $\text{W}/\text{m}^2 \text{sr}$ or as the spectral distribution of the irradiance in W/m^2
- $V(\lambda)$ – relative spectral luminosity [relative luminous efficiency of a monochromatic radiation of wavelength λ]
- λ_{colour} – wavelength range of the entire colour range to be considered (see table H5)
- λ_{total} – wavelength range of the entire visible colour range 380-780 nm

Table H5.

Colour ratios

	λ_{colour} [nm]	k_{colour}
k_{red}	610-780	$\geq 0,14$
k_{orange}	560-660	$\geq 0,50$
k_{yellow}	505-780	$\geq 0,90$
k_{blue}	380-505	$\leq 0,10$

H.3. Rear Lamps

(a) Tail lamps

Each lamp shall provide a source of red light at least 170 mm in diameter. It is permissible to use non-circular tail lamps in which case the minimum lit area shall be 22 000 mm^2 with a minimum dimension of 110 mm.

(b) Photometric requirements

The luminous intensities of tail lamps, measured along the centre line of the tail lamp, shall be as shown in Table H6 below.

Table H6.

Luminous Intensities for Tail Lamps

	Tail lamp
Luminous intensity (cd) along centre line	15-40
Luminous intensity (cd) at 7.5° on either side of the centre line in the horizontal plane	Minimum 10
Luminous intensity (cd) at 2.5° on either side of the centre line in the vertical plane	Minimum 10

Assessment is defined in clause H.4 section (b).

(c) Colourimetric requirements

The colour of light emitted by tail lamps shall comply with the requirements of CIE S004/E-2001, as shown in the table H7 below:

Table H7.

Colour range intersection points (assessment is defined in clause H.4 section (a)).

Colour of light	CIE(1931) colour coordinates of the intersection points				
	Intersection point	A	B	C	D
Red	x	0,690	0,705	0,705	0,720
	y	0,295	0,295	0,280	0,280

H.4. Conformity type testing of interoperable constituent**(a) Colourimetric tests**

These tests shall determine the colour of light emitted by the lamp over the range of angles for which luminous intensities are specified, and shall apply over the whole of the lit area of the lamp.

Test requirements

The colourimetric tests shall be carried out with at least one lamp of each type, at the rated voltage for each.

The colourimetric tests shall be carried out in a suitable darkroom, with controlled ambient temperature within the range 20 ± 2 °C.

Testing of the colour of the light emitted by the lamps shall be carried out with a precision colourimeter for absolute measurement. CIE Publication No. 15.2 contains information and recommendations on colourimetric practices and formulae, and on the calculation of tristimulus values and chromaticity coordinates. ISO/CIE 10527 contains information on partial filtering for the required 2° field size.

The measurement system for the colourimetry shall be checked before each test with a suitably calibrated light source. The check shall be documented.

The calibration of the colourimeter and light source shall be traceable to the national standard applicable to the country in which the lamp is tested.

The colourimetric tests shall be carried out using a goniometer. The lamp shall be fixed on the goniometer and inclined horizontally and vertically around the mid-point of the lit area of the lamp.

The measurement distance between the lamp and colourimeter shall be sufficient to ensure that the detector surface is illuminated fully and uniformly without any structural detail of the light beam. This measurement distance shall be documented.

During the tests, the electrically powered lamp shall be operated at a constant test voltage equal to the rated voltage for the lamp. In order to obtain an accurate result, the voltage shall be measured as close to the lamp as possible. The test voltage and current shall be documented.

Electrical light sources shall be aged before being submitted for the tests, and stabilised directly before the tests, for the required periods shown in Table H8.

Table H8.

Ageing and stabilisation period for different light source types

Light source type	Ageing period	Stabilisation period
Incandescent lamp	1 % of the nominal service life, but at least 1 hour	15 minutes
LED	50 hours	1 hour
Halogen metal vapour lamp	100 hours	30 minutes
Mercury vapour high pressure lamp	100 hours	20 minutes
Sodium vapour high pressure lamp	100 hours	20 minutes

(b) Photometric tests

These tests shall determine the luminous intensity of light emitted by the lamp over the range of angles for which luminous intensities are specified, and shall apply over the whole of the lit area of the lamp.

The photometric tests shall be carried out with at least one lamp of each type, at the rated voltage for each.

The photometric tests shall be carried out in a suitable darkroom, with controlled ambient temperature within the range 20 ± 2 °C.

The luminous intensity shall be measured with a photometer with a measuring range of at least 1 to 100 000 cd.

The f1 error of the photometer with reference to the $V(\lambda)$ spectral response, according to CIE Publication No. 69 shall not exceed 1,5 %. The photometer shall have a device or devices to reduce internal reflections without covering parts of the detector surface.

The measurement system for the photometry shall be checked before each test with a suitably calibrated light source. The check shall be documented.

The calibration of the photometer and light source shall be traceable to the national standard applicable to the country in which the lamp is tested.

The photometric tests shall be carried out using a suitably calibrated goniometer. The lamp shall be fixed on the goniometer and inclined horizontally and vertically around the mid-point of the lit area of the lamp.

The measurement distance between the lamp and photometer shall be sufficient to ensure that the detector surface is illuminated fully and uniformly without any structural detail of the light beam. This measurement distance shall be documented.

During the tests, the electrically powered lamp shall be operated at a constant test voltage equal to the rated voltage for the lamp. In order to obtain an accurate result, the voltage shall be measured as close to the lamp as possible. The test voltage and current shall be documented.

Electrical light sources shall be aged before being submitted for the tests, and stabilised directly before the tests, for the required periods shown in Table H8.

Where the photometric tests are conducted on light-unit only, a type-test shall be carried out in the as-installed condition to account for variations in power supply, lenses and protective covers.

ANNEX I

Information required to appear in the 'register of rolling stock'**I.1. General information**

The register of rolling stock shall contain the following sections.

- A. Definition of the scope
- B. Names of parties involved
- C. Conformity assessment and suitability for use process
- D. Characteristics of the rolling stock
- E. Safety critical maintenance data

I.2. Section A: Definition of the scope of the register of rolling stock

This section of the register contains the identification and the intended use of the rolling stock covered by this register. This section shall contain the following information.

Type identification (unique characteristic by which the vehicles covered by this register can be recognised)

Type designation (name of the rolling stock, optional)

Vehicle Identification (alphanumeric identification code)

Class (class 1 or 2)

Type (trainset, EMU, DMU, power head, electric or diesel locomotive, or coach, for electric locomotive $P > 4\,500$ kW or $P < 4\,500$ kW)

Defined Formations, in the case of single vehicles, the defined formations in which the vehicle is certificated to run, shall also be listed.

Field of application (for trainsets: possibility to couple trainsets together; for vehicles: rules to be applied to compose interoperable trains using this vehicle)

I.3. Section B: Names of parties involved

This section of the register contains identification of the parties that are or have been involved in the design, manufacturing and operation of the rolling stock subsystem and of the on-board assemblies of other subsystems. It shall state the identity of each of the following parties.

When more than one party has been responsible for one role, the register shall state each party and the apportionment of the responsibilities between them.

Keeper (The party, who being the owner or having the right to dispose of it, exploits a vehicle economically in a permanent manner as a means of transport (COTIF, Annex D 'CUV' Article 2))

Owner

Railway undertaking responsible for the technical management of the rolling stock.

Railway Undertaking responsible for the operation of their rolling stock.

Main contractor or manufacturer(s) or his authorised representative (parties, whose activities contribute to fulfil the essential requirements of the TSI). It concerns the parties

- responsible for the whole subsystem project (including in particular responsibility for subsystem integration)
- other companies only involved only in a part of the subsystem project (performing for example design, assembly or installation of the subsystem).

I.4. **Section C: Conformity assessment**

This section of the register contains the documentation of the conformity assessment.

Certificate of conformity (Notified body, date and identification)

Authorisation for placing in service (National Authority, date and identification)

TSI (version or versions of the TSI that have been applied)

Items that shall be verified by **in service experience** and the arrangements that have been made to cover these items

I.5. **Section D: Characteristics of the rolling stock**

This section of the register contains three subsections:

- Section D.1: the rolling stock subsystem,
- Section D.2: the onboard assembly of the Control-Command and Signalling subsystem,
- Section D.3: the on-board assembly of the energy subsystem.

I.5.1. Subsection D.1 for the rolling stock subsystem

This subsection of the rolling stock register shall contain

- Results of the conformity assessment for all characteristics in Table E.1 of Annex E where there is an accepted derogation or where there is a choice of values. This information shall be given in the format of Table I.1.
- Results of the conformity assessment for all characteristics on which this TSI contains specific cases (all characteristics in chapter 7.3). This information shall be given in the format of Table I.1.
- Result of the conformity assessment for requirements in Annex L (National Rules) of the High speed rolling stock TSI, if applicable. This information shall be given in the format of Table I.1.
- Characteristics of rolling stock as set out in Table I.1.
- References to documents that are referred to in the high speed rolling stock TSI, 4.2.1.1a) and 4.2.7.9.1 Degraded modes, 4.2.7.5 Lifting/rescue procedures
- Reference(s) to certificate(s) of interoperability constituents that are to be used in the rolling stock subsystem

I.5.2. Subsection D.2 for the control-command and signalling subsystem

This subsection of the rolling stock register shall contain the information mandated by other TSIs in relation to the control-command and signalling subsystem on board of rolling stock. The format of this information shall comply with the format set out in Table I.1.

I.5.3. Subsection D.3 for the energy subsystem

This subsection of the rolling stock register shall contain the information mandated by other TSIs in relation to the energy subsystem on board of rolling stock. The format of this information shall comply with the format set out in Table I.1.

I.6. **Section E: Maintenance data**

The entity responsible for the rolling stock and the management of the technical file

The reference to the maintenance documentation as defined in clause 4.2.10.2.2 of this TSI

The safety critical data relating to the maintenance (see clause 4.2.10.2.2)

Table I.1

Entries in subsection D.1 of the rolling stock register

Clause	Characteristic of the rolling stock	Type, value or option
4.2.1.1.b	Maximum service speed of trainsets	Maximum speed
4.2.2.2	End couplers	Type of end coupler
4.2.2.4.1	Passenger step (pending requirements of PRM TSI)	Platform heights for which the rolling stock is compatible
4.2.3.1	Kinematic gauge	Kinematic vehicle gauge used
4.2.3.2	Static axle load	Value
4.2.3.3.2	Axle bearing health monitoring	Shielded y/n Class 2: equipped with on board y/n
4.2.3.4.3 a)	Vertical dynamic wheel load	Value
4.2.3.4.5	Design for vehicle stability	Speed Conicity range or presence of independently rotating wheels
4.2.3.5	Maximum train length	Value
4.2.3.6	Maximum gradients	Value
4.2.4.7	Brake performance on steep gradients	
4.2.3.7	Minimum curve radius	Value
4.2.4.1	Minimum braking performance	Braking curve and means of braking to achieve performance
4.2.6.1	Environmental conditions	Climatic zone
4.2.6.2.2	Aerodynamic loads on passengers on a platform	Platform height used for assessment
4.2.7.2	Fire safety	Category A or B fire safety
4.2.8.3.1.1	Energy supply	Values of voltage and frequency
4.2.8.3.2	Max. power and maximum current that it is permissible to draw from the catenary	Values

ANNEX J

Windscreen properties

J.1. Optical Properties

The windscreen, as orientated and installed in the driving cab, shall have minimal Distortion of Vision over the whole of the vision area.

J.1.1. Optical Distortion

Simple distortions of vision when measured using the method set out in ECE R 43 A3/9.2, or in Section 5.3 of ISO 3538:1997 shall not exceed the following values:

- (a) max. 2,5 minutes of arc in the Primary Vision Area;
- (b) max. 6,5 minutes of arc in the Secondary Vision Area;

There shall not be any noticeable discontinuities of the projected lines within the Primary and Secondary Vision Areas.

Figure J.1

Windscreen Areas

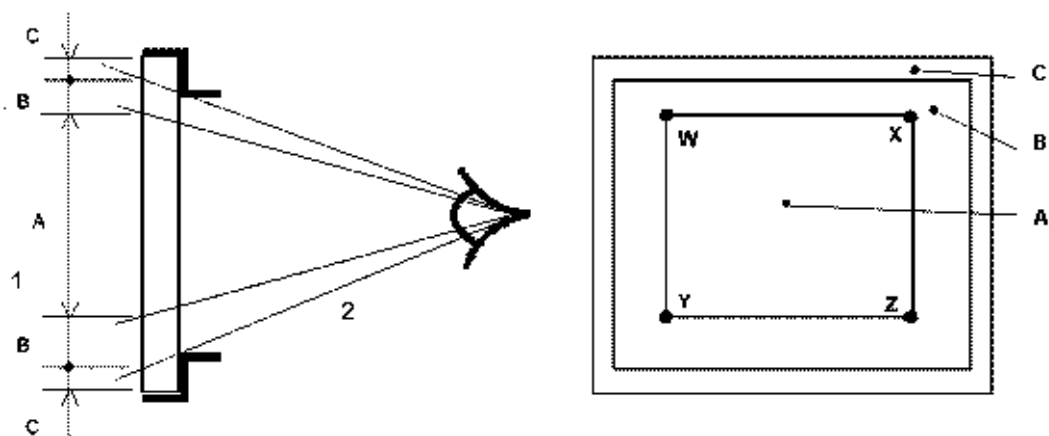

Key

1	Outside	Area A	Primary Vision Area
2	Inside	Area B	Secondary Vision Area
		Area C	Peripheral Area

The four points W, X, Y and Z are the result of the crossing between the outside of the windscreen and the virtual lines between the driver's eyes and the high or low signals.

These points shall be connected each other by a line as in the diagram above.

J.1.2. Secondary Images

The windscreen when installed in the cab shall not cause Secondary Image Separations that may cause confusion or distraction to the driver.

The permissible angle between primary and secondary images in the installed position shall not exceed:

- 15 minutes of arc for the primary vision area
- 25 minutes of arc for the secondary vision area

J.1.3. Haze

The maximum value of haze shall not exceed 2 % when measured as set out ECE R 43 A3/4.

J.1.4. Transmittance

The primary and secondary vision areas of the windscreen shall have a Visual Transmission of more than 65 % in the installed position, as measured in accordance with ECE R 43 A3/9.1 or with clause 5.1 of ISO 3538:1997

J.1.5. Chromaticity

Requirements related to chromaticity remain an open point

J.2. **Structural requirements**

J.2.1. Impacts

The resistance of the front windows to projectiles shall be assessed as follows:

A cylindrical projectile shall be fired at the front window. The projectile shall be constructed as shown in Figure J.2. If the projectile sustains permanent damage after impact it shall be replaced.

For the test, the front window shall be fixed in a frame of the same construction as that mounted on the vehicle.

The temperature of the window during the tests shall be between + 15 °C and + 35 °C. The projectile is assumed to impact at right angles to the window or alternatively the test window can be mounted at the same angle to the track as it is mounted in the vehicle.

The projectile's impact velocity shall be determined by:

$$\begin{aligned}V_p &= V_{\max} + 160 \text{ km/h} \\V_p &= \text{Velocity of the projectile in km/h on impact} \\V_{\max} &= \text{Maximum velocity of the trainset in km/h}\end{aligned}$$

The test result shall be deemed satisfactory if:

- the projectile does not break through the front window;
- the window remains in its frame.

Figure J.2

Diagram of projectile

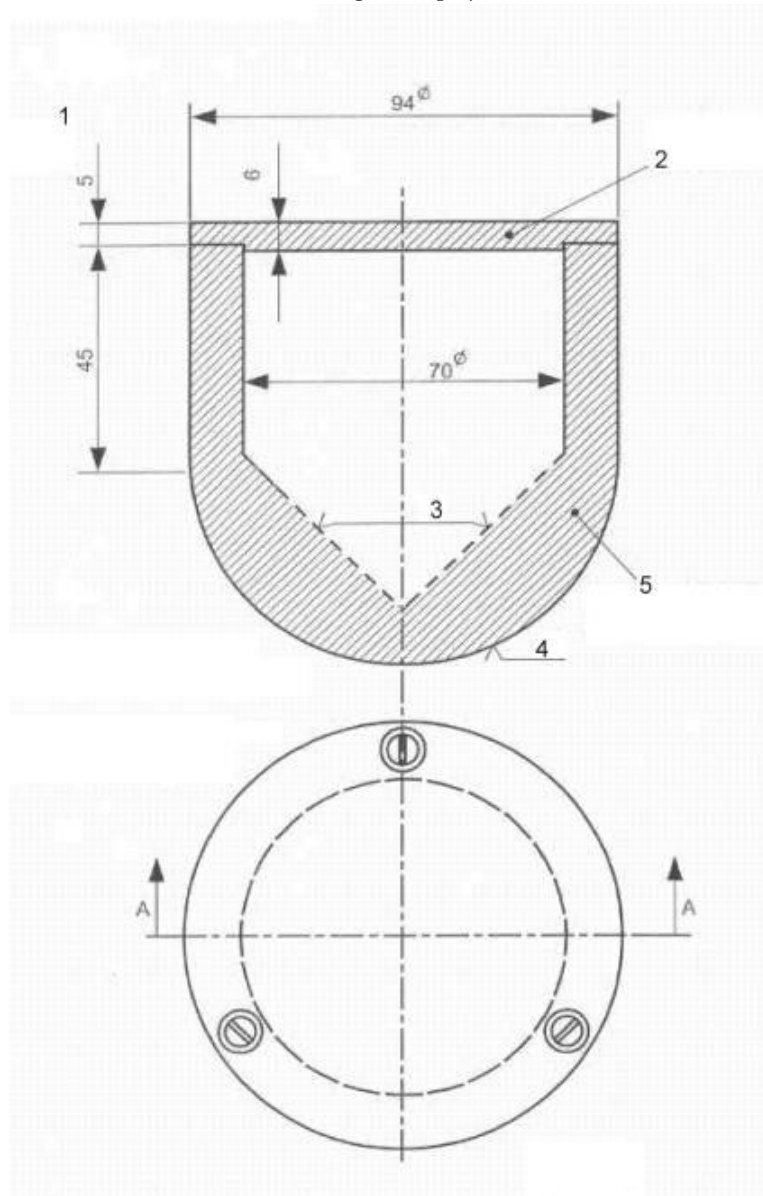

Key

1	Section A-A	4	Milled surface of hemispheric tip (1 mm)
2	Extremity of steel projectile	5	Projectile in aluminium alloy
3	Material may be removed for adjustment purposes		The mass of the projectile shall be 1 000 g.

J.2.2. Spalling

The driver shall be protected from spalling.

The spalling test shall be verified during the tests of impacts of projectiles set out in clause 4.2.2.7 c) of this TSI. A sheet of aluminium of maximal thickness 0,15 mm and of dimension 500 mm by 500 mm shall be placed vertically behind the sample tested at a distance of 500 mm and in the direction of travel of the projectile. The spalling test shall be deemed satisfactory if the aluminium sheet is not perforated.

ANNEX K

Coupler

K.1. Schematic of the coupler

The towing coupler shall comply with the dimensions in Figure K1 but its shape is permitted to be different

Figure K1

Dimensions of the coupler

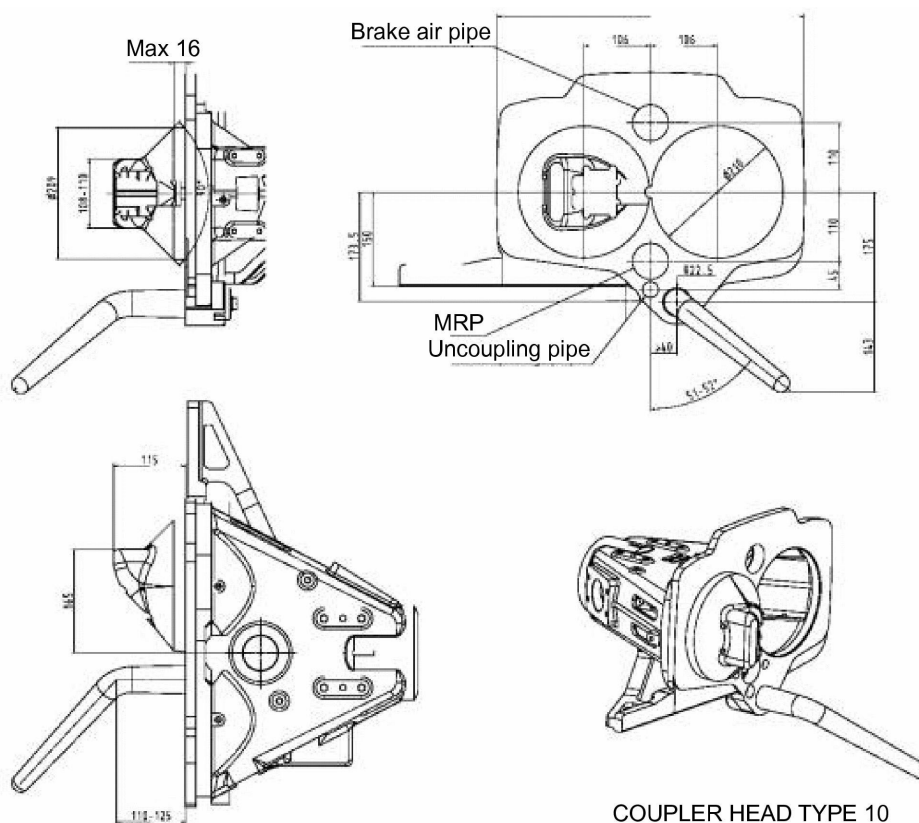

The centre of the end coupler shall be at $1\,025\text{ mm} +15\text{ mm}/-5\text{ mm}$ above running surface, for an empty vehicle in running order condition and with new wheels

K.2. Towing coupler used for recovery and rescue

K.2.1. Definition of terms

Recovery vehicles (locomotives, trains) are denoted by the term '**recovery vehicle**'.

The rescue, emergency and recovery coupler on the recovery vehicle covered in this annex is denoted by the term '**towing coupler**'.

The automatic coupler system shall be geometrically and functionally compatible with a 'Type 10 latch system automatic centre buffer coupler' (also known as the 'Scharfenberg' system) and referred to herein as an '**automatic coupler**'.

The term '**draw hook**' refers to a draw hook of shape and dimensions conforming to clause 4.2.2.1.2 of the Freight Wagon TSI 2005; the reference height above rail level (ARL) is defined as being $1\,025\text{ mm} + 15\text{ mm}/- 5\text{ mm}$ for an empty vehicle in running order conditions and with new wheels.

The term '**half coupler**' is adopted to describe the brake couplers to be connected to the air pipes between the vehicle and the rescue coupler (main brake pipe and main air pipe).

K.2.2. General conditions

K.2.2.1. Speeds

Permissible speeds when recovering trains are:

	minimum speed	recommended speed
Pulled	30 km/h	100 km/h
Pushed	30 km/h	

K.2.2.2. Brakes

The train to be recovered shall be connected to the brake pipe of the recovery vehicle and braked from there.

K.2.2.3. General Pneumatic connection

All trains shall be able to be moved safely and braked when connecting the main brake pipe only. It is permissible to connect the main air reservoir pipe only when a specific procedure defined by the operator of the recovered vehicle allows it. Where the main air reservoir pipe cannot be connected operational rules shall be provided to continue to assure safety of passengers.

K.2.2.4. Coupling Process

The recovery vehicle shall come to a complete halt in front of the vehicle being recovered. The recovery vehicle shall then proceed at a maximum speed of 2 km/h to engage the two couplers.

K.2.2.5. Uncoupling conditions

It is permissible to uncouple manually or automatically

K.2.3. Towing a train fitted with an automatic coupler by means of a towing coupler

K.2.3.1. General conditions

When a train fitted with an automatic coupler is hauled by a motive power unit fitted with buffing and draw gear components and a towing coupler, the towing coupler shall, as a minimum, be able to withstand the following static forces without permanent deformation:

- tensile force at the coupler 300 kN
- compressive force at the coupler 250 kN

K.2.3.2. Coupling conditions

Mechanical connection

The towing coupler shall be designed to be installed by two people in a maximum time of 15 minutes, its maximum weight shall not exceed 45kgs.

The mechanical connection between the train's coupler and the towing coupler fitted to the recovery vehicle shall be established automatically.

It shall be ensured that the towing coupler fitted to a vehicle with buffing and draw gear components is able to be connected to the automatic coupler on the other vehicle, to allow train running on horizontal curves of $R \geq 150$ m or on vertical curves of $R \geq 600$ m on a crest or $R \geq 900$ m on a hollow (see High Speed Infrastructure TSI 2006 clause 4.2.25.3)

Readiness for hauling shall be brought about by hooking the towing coupler onto the draw hook of the recovery vehicle and fastening it to the draw-hook itself.

The towing coupler shall be fastened in such a way that, whilst it cannot be worked loose by any relative motion occurring, it shall not impair the freedom of movement of the draw hook.

The towing coupler shall be provided with all necessary parts for installation and no additional tools shall be needed for installation.

Once the towing coupler has been installed on the draw hook of the vehicle,

- the towing coupler shall be able to be centred on the draw hook by hand
- the draw hook's normal horizontal play shall not be impaired
- the draw hook's normal vertical play shall not be impaired
- the vertical fastening on the towing coupler shall be easy to handle
- any tilting mechanism shall be turned off.

In order not to exceed the towing couplers mechanical strength, the difference in the centre heights of the towing coupler and the coupler on the train being recovered shall not exceed 75 mm.

Pneumatic connection

The air pipes (main brake pipe and main air pipe) shall be connected as follows:

The air hoses on the recovery vehicle shall be joined to the corresponding air connectors on the coupler by means of the half couplers (see Figure K2).

It shall be ensured in the process that the air pipes are free to move about their longitudinal axes.

Figure K2

Air-pipe connection between coupler and recovery motive power unit

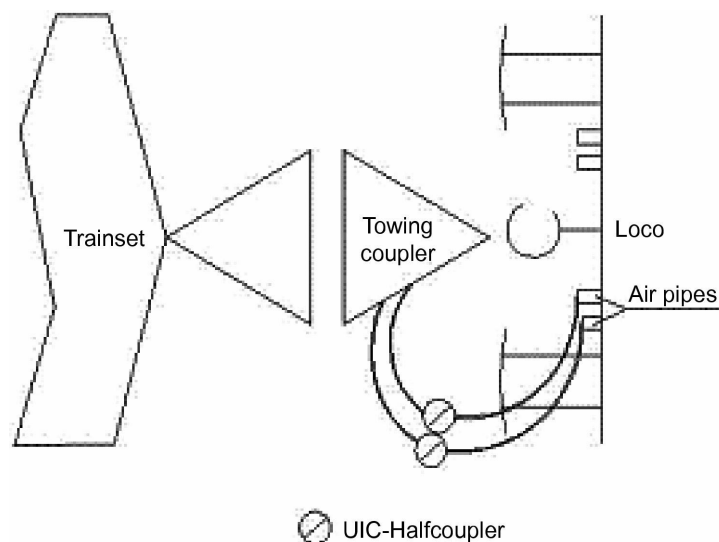

It is permissible to equip Class 1 and Class 2 when fitted with automatic couplers, with additional air pipe connectors for a direct connection of the air pipes to the recovery vehicle.

K.2.4. Towing a train fitted with a draw hook by means of a towing coupler

K.2.4.1. General conditions

All requirements requested in previous section K.2.3 shall be applicable, taking into account the following modifications resulting from the towing coupler installation.

K.2.4.2. Coupling conditions

Mechanical connection

The mechanical connection between the rescued train's towing coupler and the automatic coupler fitted to the recovery vehicle shall be established automatically.

Pneumatic connections

The air pipes (main brake pipe and main air pipe) shall be connected via the corresponding air ducts. It is not essential to pneumatically connect the uncoupling lines.

ANNEX L

Aspects not specified in the High Speed Rolling Stock TSI and for which notification of national rules is required**General**

Additional requirements for rolling stock having a maximum speed higher than 351 km/h (clause 1.1)

Mechanical parts

Bogies: design, fabrication and approval — Steel grade used — Resistance — Vibrations dampening, Critical twisting resonance (traction unit)

Bogie curving behaviour

Wheelset: design, fabrication and approval — Defects of rolling contact permitted in operation

Equipment attached to vehicle bodies, bogie frames and axle boxes and its attachment requirements

Resistance to fatigue loads

Certification processes for non destructive testing

Suitability for gravity shunting: couplers, passing over shunting bumps, resistance to shunting shocks

Identification of rail vehicles (clause 4.2.7.15)

Passenger steps (clause 4.2.2.4.1)

Hot axle boxes detection system: alarm levels (clause 4.2.3.3.2)

Safety, health and ergonomic requirements for driver seats (4.2.2.6)

Windscreen chromaticity requirements

Dynamic Behaviour

Limitation of the quasi static guiding force Y_{qst}

Braking

Pneumatic brake: characteristics (including automatic immobilisation in case of coupling rupture)

Other brake types

Use of composite brake blocks

Brake pad/brake disc friction coefficient reduction due to dampness (Annex P)

Traction/Energy

Electrical protection of the train: circuit breaker location, damages downstream from the circuit breaker of the train

Control of the pantographs, backup mechanism for rising the pantograph in the absence of air in the main tank

Protection of the catenary: from hot exhaust gases

Diesel and other thermal traction systems

Quality of fuel for Diesel and other thermal traction systems

Refuelling equipment (clause 4.2.9.8)

Control-Command and interfaces with signalling

Interference generated on the signalling system and the telecommunications network: (clause 4.2.6.6.1)

Equipment for driver only operation

Safety

Safety integrity levels (SIL) for safety related functions

Safety and health of persons (Already covered by EU Dir. 58/2001?)

(A) Instruction to passengers for a safety-conscious behaviour Indication on evacuation procedures and use of emergency exits in adequate languages

Food preparation and storage (*)

Electromagnetic compatibility with pacemakers (*)

Internal crash worthiness

Fire safety

Measures to prevent fire (clause 4.2.7.2.2)

Environment

Exhaust gases of thermal engines

Use of prohibited or restricted materials and products (asbestos, PCB, CFC, etc.)

Operation

Vehicle Recovery

Aerodynamics

Effects of crosswinds for class 1 tilting trains and class 2 trains (clause 4.2.6.3)

Aerodynamic effects on ballast (clause 4.2.3.11)

Assessment

Assessment of Maintenance Arrangements: Conformity Assessment Procedure (Annex F clause F.4)

(*) Health issues that are not railway specific but need specification.

ANNEX M

In service limits of the geometric dimensions of wheels and wheelsets

Table M.1.

Dimensions for 1 435 mm track gauge

Designation	Wheel diameter D (mm)	Minimum value (mm)	Maximum value (mm)
Requirements linked to subsystem			
Distance between flange contact faces (S_R) $S_R = A_R + S_d(\text{left wheel}) + S_d(\text{right wheel})$	≥ 840	1 410	1 426
	< 840 and ≥ 330	1 415	1 426
Back to back distance (A_R)	≥ 840	1 357	1 363
	< 840 and ≥ 330	1 359	1 363
Requirements linked to interoperability constituent wheel			
Width of the rim ($B_R + \text{Burr}$)	≥ 330	133	145
Thickness of the flange (S_d)	≥ 840	22	33
	< 840 and ≥ 330	27,5	33
Height of the flange (S_h)	≥ 760	27,5	36
	< 760 and ≥ 630	30	36
	< 630 and ≥ 330	32	36
Face of flange (q_R)	≥ 330	6,5	
Wheel tread defects, e.g. wheel flats, shelled treads, cracks, grooves, cavities etc	National rules apply until EN is published		

The dimension A_R is measured at the top surface of the rail. The dimensions A_R and S_R shall be complied with in laden and tare conditions and for loose wheelsets. For specific vehicles smaller tolerances within the above limits may be specified by the vehicle supplier.

Figure M.1.

Symbols

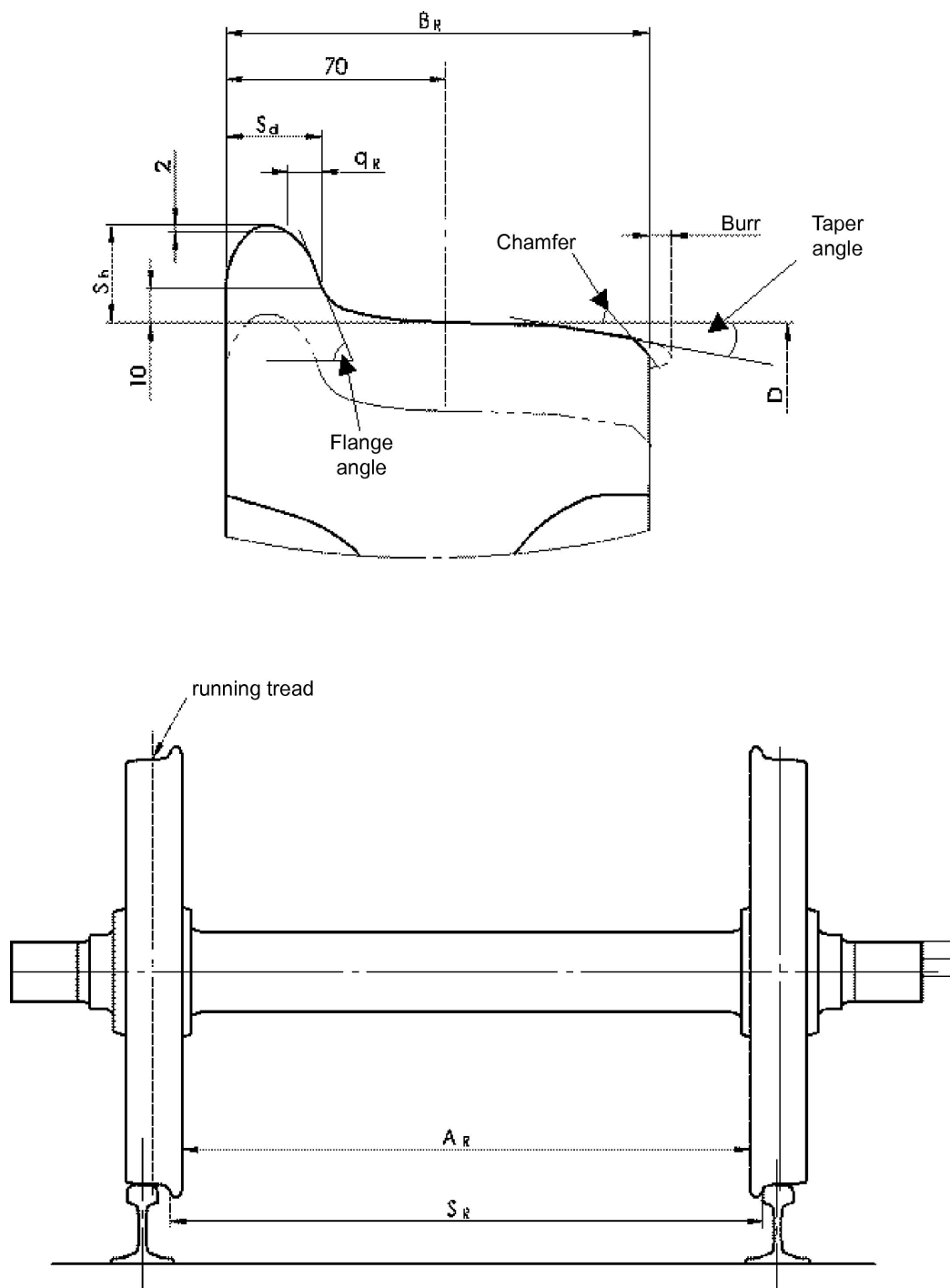

Table M.2.

Dimensions for 1 520 and 1 524 mm track gauges

Designation	Wheel diameter (mm)	Gauge (mm)	Minimum value (mm)	Maximum value (mm)
Requirements linked to subsystem				
Distance between outside surfaces of the flange (S_R)	≥ 840	1 520	1 487	1 509
		1 524	1 487	1 514
Distance between inner faces of the flange (A_R)	≥ 840	1 520	1 437	1 443
		1 524	1 442	1 448
Requirements linked to interoperability constituent wheel				
Width of the rim (B_R)	≥ 840	1 520	130	145 ⁽¹⁾
		1 524	134	145 ⁽¹⁾
Thickness of the flange (S_d)	≥ 840		20	33
				36 ⁽²⁾
Height of the flange (S_h)	≥ 840		28	36
Face of flange (Q_R)	≥ 840		6,5	

Dimensions above are indicated as a function of the height of the upper rail level and shall be met by empty or loaded rolling stock.

⁽¹⁾ Burr value included

⁽²⁾ Only allowed when A_R is 1 442

ANNEX M I

Not used

—

ANNEX M II

Not used

—

ANNEX M III

Not used

—

ANNEX M IV

Seals for the toilet discharge system connections

Fig. M IV.1

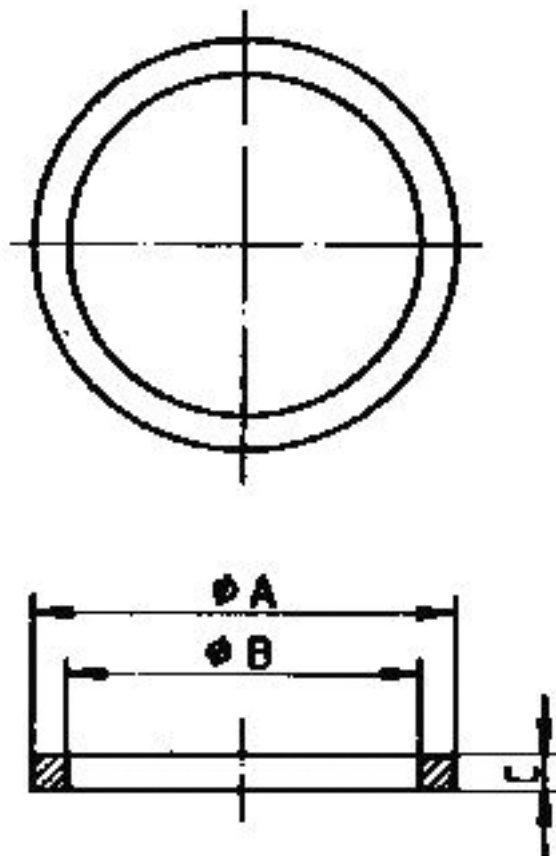

	A [mm]	B [mm]	C[mm]
Seals 3"	94,45	76,20	6,35
Seals 1"	39,69	26,98	6,35

General tolerances $\pm 0,1$

Material: Elastomer, faeces-resistant e.g. FPM (fluoro rubber)

Fig. M IV.2.

3" Evacuation connection and 1" flushing connection (outer parts)

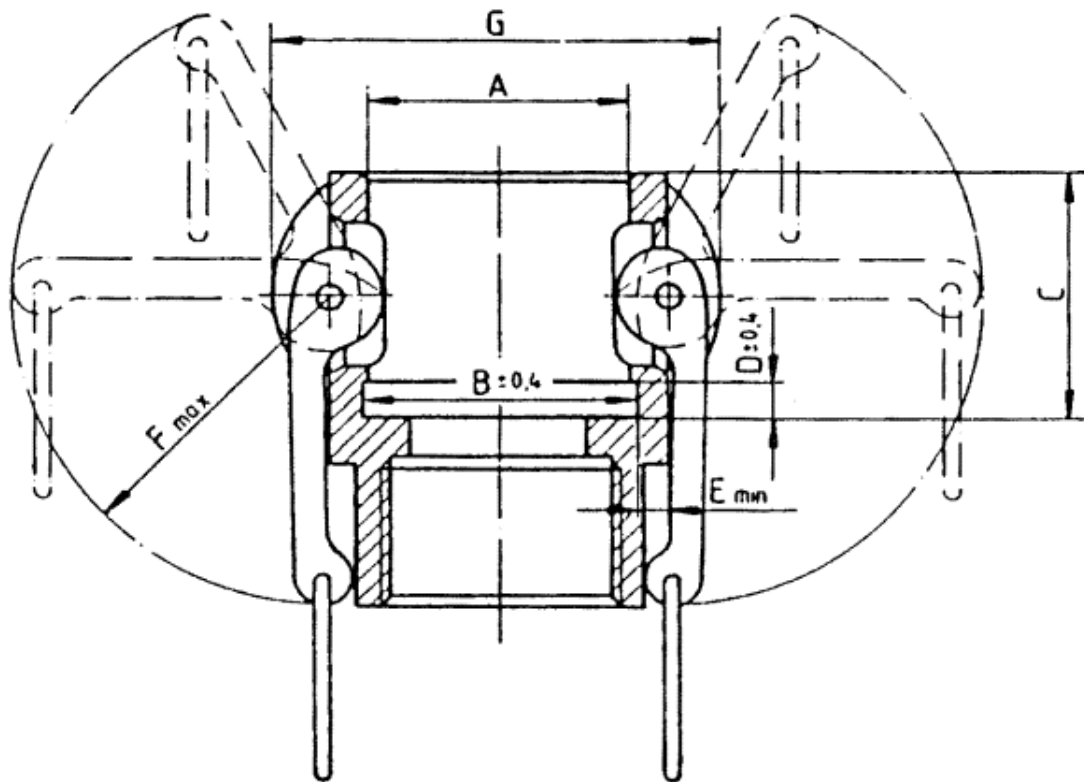

	A	B	C	D	E	F	G
3" Coupler	92,20	104	55	7,14	4	82,55	133,3
1" Coupler	37,24	40,50	37,50	7,14	2,4	44,45	65

General tolerances $\pm 0,1$

Material: stainless steel

ANNEX M V

Inlet connections for water tanks

Fig. M V.1

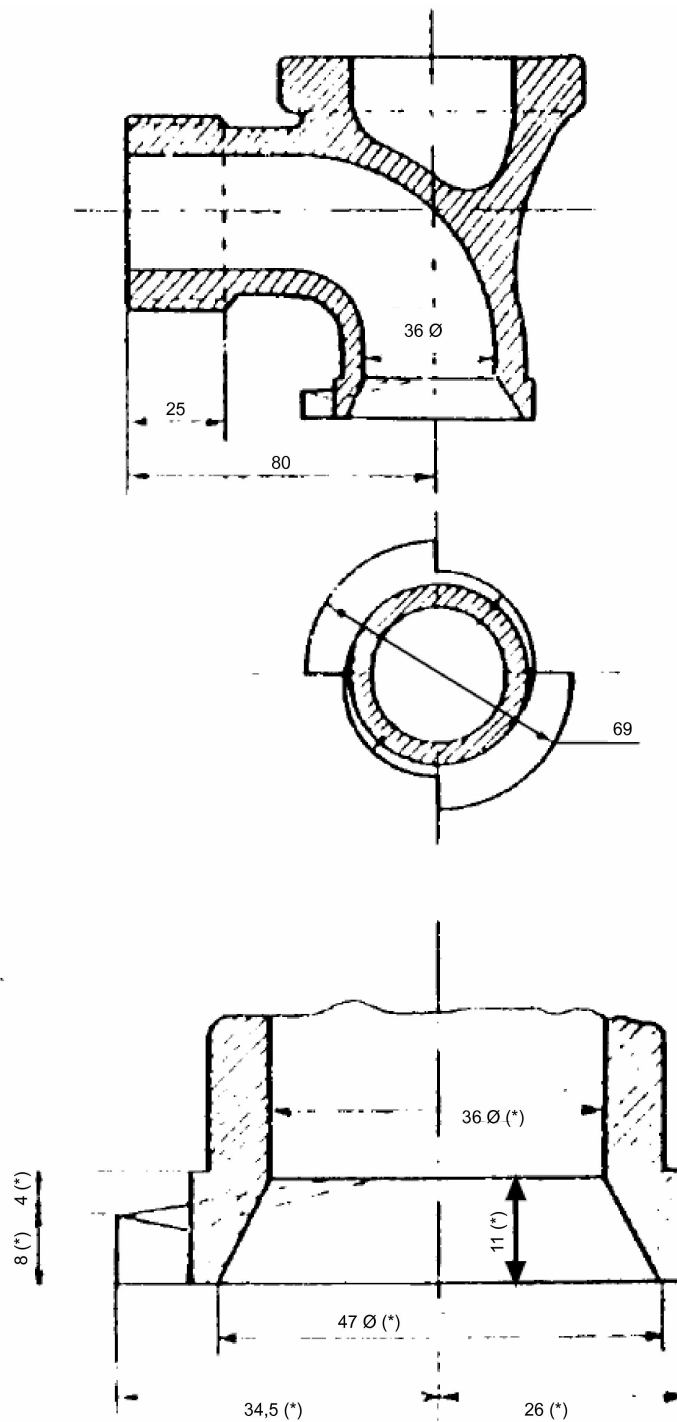

(*) obligatory value

ANNEX M VI

Connections for the toilet discharge system on rolling stock

Fig. M VI.1.

3" Evacuation nozzle (Inner part)

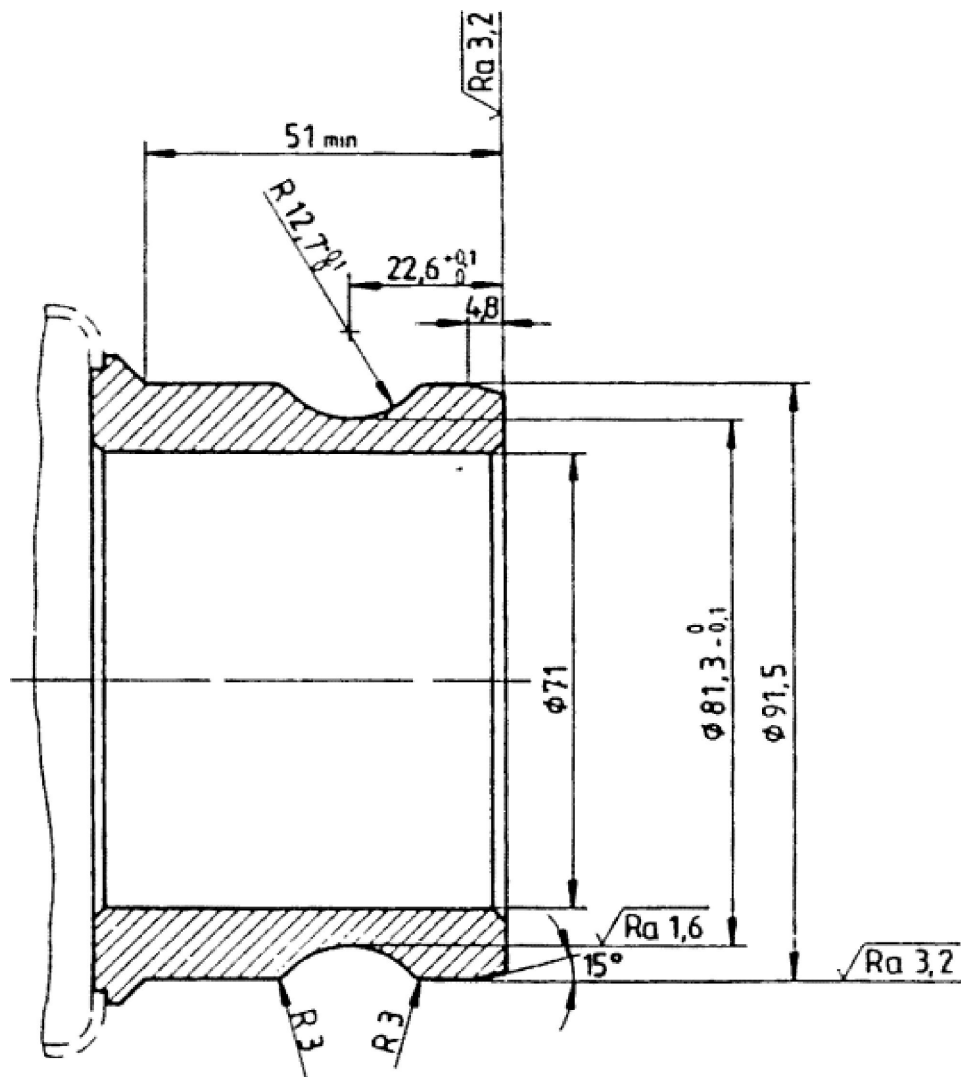

General tolerances $\pm 0,1$
Material: stainless steel

Fig. M VI.2.

1" Optional flushing connection for the toilet tank (Inner part)

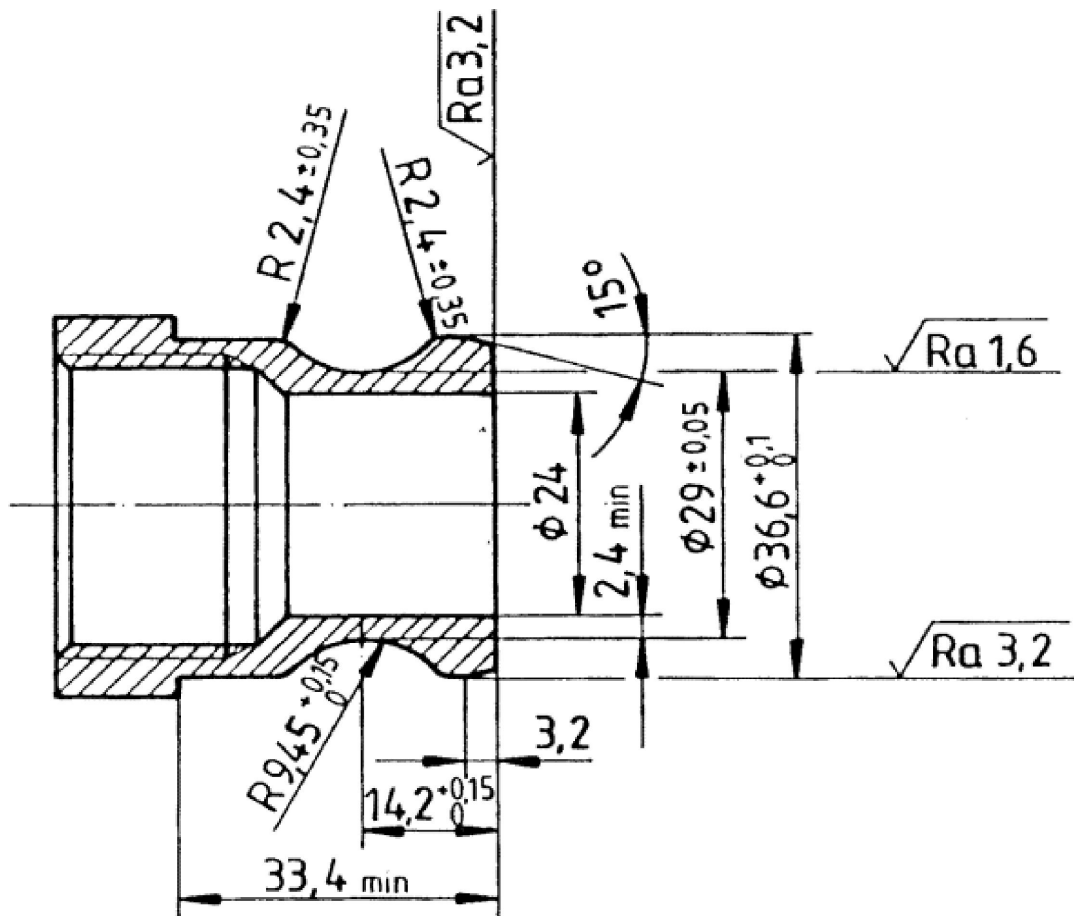

General tolerances $\pm 0,1$

Material: stainless steel

ANNEX N

Measuring Conditions for Noise

N.1. Deviations from EN ISO 3095:2005

N.1.1. Stationary noise

The measurement of stationary noise shall be made according to EN ISO 3095:2005 with the following deviations (see Table N1).

Normal operation is defined by performance at an external temperature of 20 °C. Design parameters for forcing the operation in order to simulate 20 °C conditions are to be provided by the manufacturer.

Table N1

Stationary noise, deviations from EN ISO 3095:2005

Clause (EN ISO 3095:2005)	Subject	Deviation (marked in bold, italic characters)
6.2.3	Microphone positions, measurements on stationary vehicles	<p>Measurements shall be made according to EN ISO 3095:2005 Annex A, Figure A.1 with at least six microphones placed each side of the train. If regular spacing is not applied it is necessary to include a surface weighting in the energy average according to the following formula:</p> $L_{pAeq,stationary} = 101g \sum_{i=1}^N \left(\frac{S_i}{S_{total}} 10^{L_{pAeq,i}/10} \right)$ <p>where S_i = area of measurement surface i, $L_{pAeq,i}$ = measured level at point i, N = total number of measurement points, S_{total} = total measurement surface area.</p>
6.3.1	Vehicle conditions	Fouling on grilles, filters and fans shall be removed before the measurements.
7.5.1	General	The measuring time is to be 60 s.
7.5.2	Coaches, wagons and electric power units	All equipment that can operate with the vehicle stationary, including the main traction equipment where relevant, but excluding the brake air compressor, shall be operating. The auxiliary equipment shall be operated at normal load.
7.5.3.1	Power units with internal combustion engines	Engine idling unloaded, fan at normal speed, auxiliary equipment with normal load, brake air compressor not operating.
7.5.3.2	Power units with internal combustion engines	This clause is not relevant for Diesel locomotives and DMU's
7.5.1	Measurements on stationary vehicles, general	The sound level of the stationary noise is the energy average of all measured values taken at the measurement points according to EN ISO 3095:2005 Annex A, Figure A.1.

N.1.2. Starting noise

The measurement of starting noise shall be made according to EN ISO 3095:2005 with the following deviations (see Table N2).

Normal operation is defined by performance at an external temperature of 20 °C. Design parameters for forcing the operation to simulate 20 °C conditions are provided by the manufacturer.

Table N2

Starting noise, deviations from EN ISO 3095:2005

Paragraph (EN ISO 3095: 2005)	Subject	Deviation (marked in bold, italic characters)
6.1.2	Meteorological Conditions	Measurements on accelerating vehicles shall be made only if the rail is dry.
6.3.1	Vehicle conditions	Fouling on grilles, filters and fans shall be removed before the measurements.
6.3.3	Doors, windows, auxiliary equipment	Tests on accelerating trains shall be performed with all auxiliary equipment operating at normal load. The sound emission of brake air compressors shall not be taken into account.
7.3.1	General	Tests have to be performed with maximum tractive effort without wheel spin and without macro slip. If the train under test does not comprise a fixed formation, the load has to be defined. It shall be typical of the normal service.
7.3.2	Trains with an individual power unit	Tests on accelerating trains shall be performed with all auxiliary equipment operating at normal load. The sound emission of the brake air compressors shall not be taken into account.

N.1.3. Pass-by Noise

Paragraph (EN ISO 3095:2005)	Subject	Deviation (marked in bold, italic characters)
6.2	Microphone position	There will be no track in-between the running track and the microphone
6.3.1	Vehicle conditions	Fouling on grilles, filters and fans shall be removed before the measurements.
7.2.3	Test procedure	A tachometer shall be used such that the speed is sufficiently accurately measured for pass-by, with train speed not in the range $\pm 3\%$ of the stated test speed to be correctly identified as being outside that range and rejected. Minimum tractive effort to maintain a constant speed shall be maintained for at least 60 s before, and during, the pass-by measurement

N.1.4. Reference track for pass-by noise

The specifications of the reference track were studied only to allow the assessment of rolling stock against pass-by noise limits. This section specifies neither the design nor the maintenance nor the operating conditions of 'normal' tracks, which are not 'reference' tracks.

Approval of the reference track shall be made according to EN ISO 3095:2005 with the following deviations.

- The rail roughness shall lie below the limit spectrum as defined in Figure N1. This limiting curve replaces the specification of EN ISO 3095:2005, Paragraph 6.4.2 (Figure 4), Annex C 'Procedure for determining the rail roughness limit spectrum'. Annex D 'Rail roughness measurement specifications', is applicable only in paragraphs D.1.2 (direct acquisition method) and D.2.1 (Processing of roughness data — Direct measurement), with the following deviations and D4 (data presentation):

Paragraph (EN ISO 3095:2005)	Subject	Deviation (marked in bold, italic characters)
D.1.2.2	Direct roughness measurement	<p>The wavelength bandwidth shall be at least [0,003; 0,10] meter</p> <p>The number of traces used to characterise the roughness will be chosen with regard to the actual rolling surface. The number of traces shall be consistent with:</p> <ul style="list-style-type: none"> — the actual contact position, and — the actual width of the rolling surface ('running band'), such that only the traces which are inside the actual width of the rolling surface are taken into account in the roughness averaging of the overall roughness. <p>Without a technical justification of these two parameters, the EN ISO 3095:2005 § D.1.2.2 is applicable</p>
D.2.1	Direct measurement	The one-third-octave band wavelength roughness spectra shall be processed from the quadratic mean of each spectrum from the elementary reference track sections.

- These methods, used in the NOEMIE project, have been shown to produce consistent results in the case of tracks fulfilling the proposed rail roughness limits. However, any other available and proven direct method, which can produce comparable results, can be used.
- The dynamic behaviour of the reference track (test track) shall be described by the vertical and lateral 'track decay rates (TDRs)', which quantify the attenuation of rail vibration with distance along the track. The method of measurement used in the NOEMIE project is presented in section N.2. It showed its ability to properly discriminate the track dynamic characteristics. The use of an equivalent track characterisation measurement method is also permitted, if available and proven. In that case, the track vertical and lateral decay rates of the test track shall be shown to be equivalent to those of the track type mentioned in this TSI, measured in accordance with the specification sheet presented in section N.2. The decay rates of the reference track shall lie above the lower limits given in Figure N2.
- The reference track shall have consistent superstructure over a minimum length of 100 m. The measured track decay rates must pertain to 40 m on each side of the microphone position. The check of the roughness shall be carried out according EN ISO 3095: 2005.

Figure N1

Rail roughness limit spectrum of the reference track

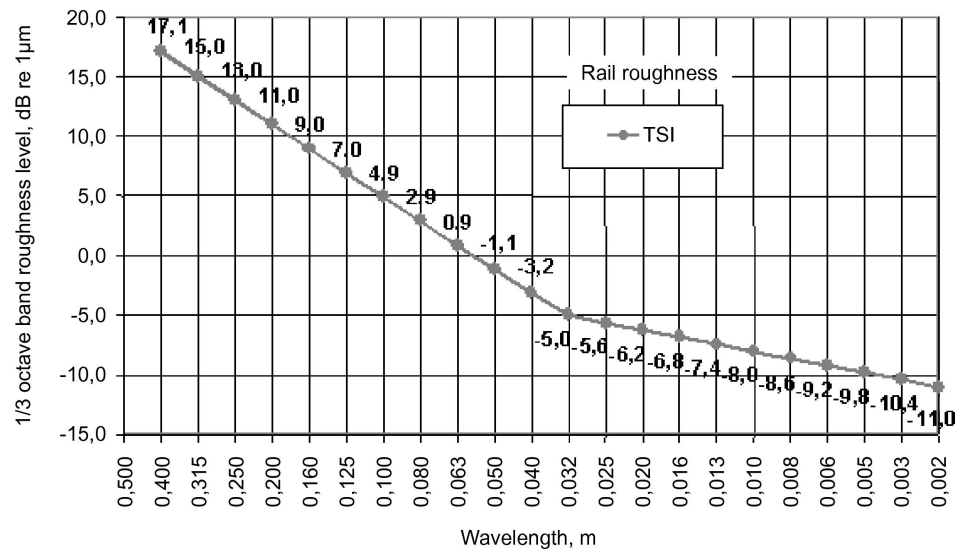
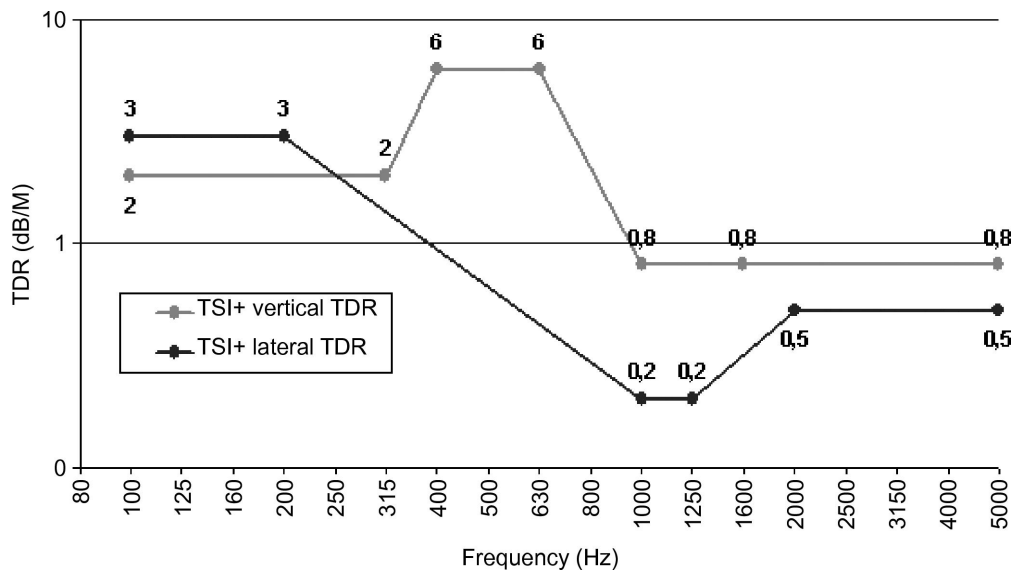

Figure N2

Vertical and lateral decay rate lower limit spectrum of the reference track



N.2. Characterisation of the dynamic performance of the reference tracks

N.2.1. Measurement procedure

The following procedure is to be applied successively in the lateral and vertical directions, on each track site to be characterised.

Two accelerometers are secured (glued or stud) on the rail, in the middle section between two sleepers (see Figure N3):

- one in the vertical direction on the longitudinal axis of the rail, positioned on the rail head (preferred), or under the rail foot,
- the other in the transversal direction, positioned on the external face of the railhead,

Figure N3

captor location on the rail cross section

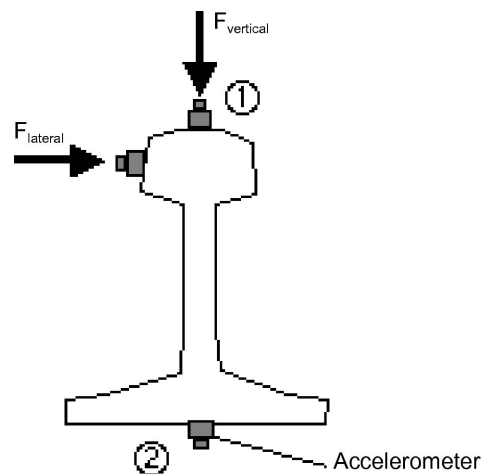

A measured force impulse is applied on the railhead, in each direction, with an instrumented hammer equipped with a tip of appropriate hardness to enable a good measurement of force and response in the frequency range [50; 6 000 Hz]. (A hardened steel tip is required for the higher end of the frequency range and is usually, though not always sufficient, to apply enough force for the lower end frequency range. An extra measurement with a softer tip may be required.)

The (transfer) accelerance (acceleration/force frequency response function) or mobility (velocity/force) is measured in the vertical and lateral-transverse directions for force applied in the corresponding same direction at an array of locations at various distances along the rail (defined below). It is not necessary to measure the cross-terms (vertical force to lateral response or vice versa). If analogue integration is available for the accelerometer measurement, it has been found that a better quality of measurement is achieved if the frequency response function (FRF) of mobility is recorded rather than accelerance. This produces better quality of data at low frequency, where the measured response is very small compared with the high frequency, since it reduces the dynamic range of the data before recording or digitization. An average FRF from at least 4 valid impulses shall be taken. The quality of each measured FRF (reproducibility, linearity etc.) shall be monitored using the coherence function. This shall also be recorded.

The transfer FRFs shall be made to the accelerometer mounting location from each of the locations indicated in Figure N4. The measurement locations can be divided into sets as the 'point' measurement location, the 'near-field' set and 'far-field' set as follows:

- The location index 0 is associated with the mid-point of the first sleeper bay. When the impulse is applied at this point (practically, as close to this point as possible), the point FRF is measured.
- The near-field measurements are carried out by applying the impulse, starting with the point FRF, at quarter sleeper spacing up to the end of sleeper bay 2, thence at half-sleeper spacing up to the middle of sleeper bay 4 and then at each mid-sleeper position up to sleeper bay 8.
- The far-field measurement use impulse locations from a distance of sleeper bay 8 from the accelerometer position outwards at the inter-sleeper positions, with the indices: 10, 12, 16, 20, 24, 30, 36, 42, 48, 54, 66, etc. as shown in Figure N4. The measurements need only be taken up to the point at which the response at all frequencies in the range becomes insignificant (with respect to the measurement noise). The coherence function provides a guide to this. Ideally, the response level in each one-third octave band shall be at least 10 dB below the level of the same band at location 0.

Figure N4

Track decay rates — location of the excitation points

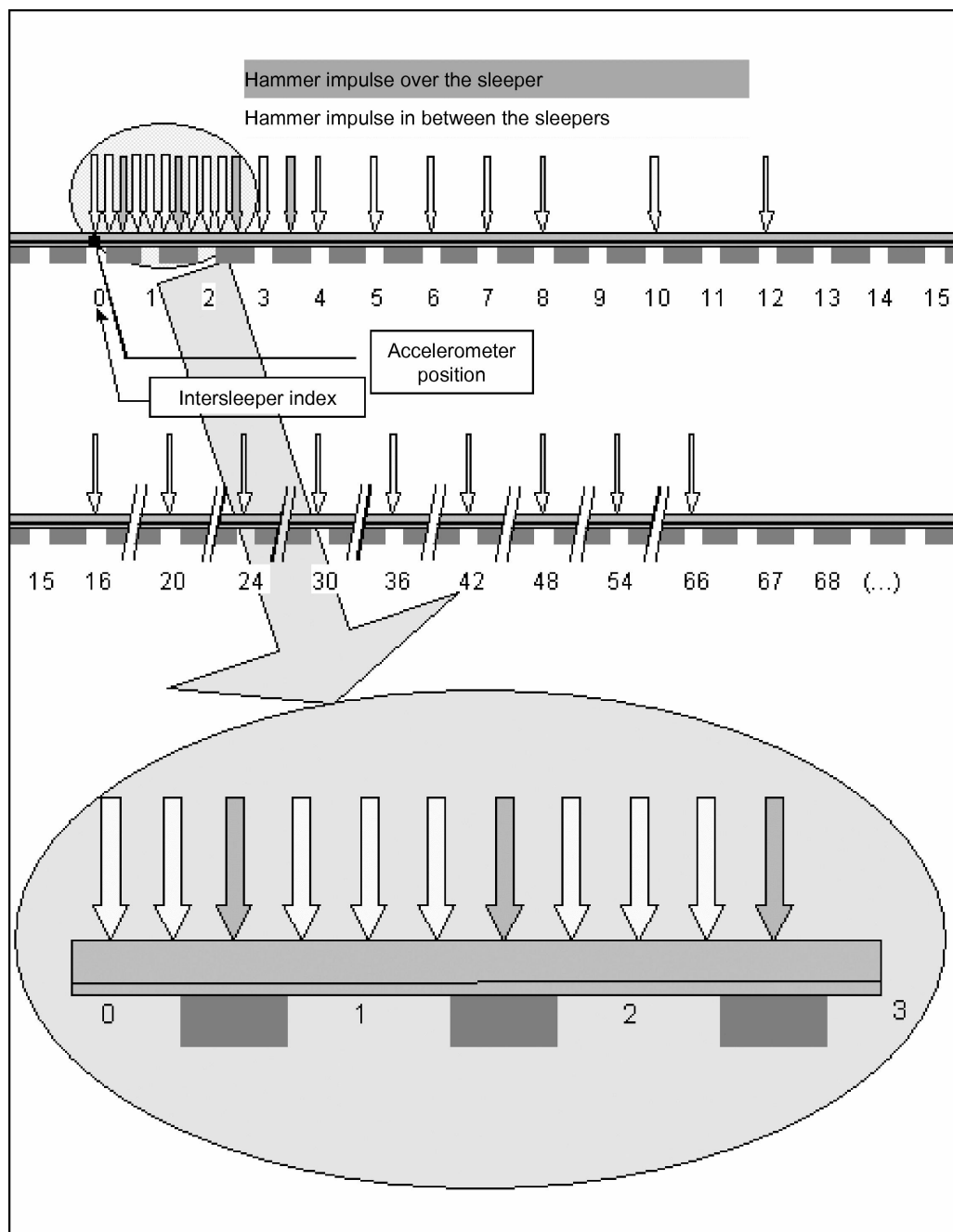

Experience has shown that the variability of the results is such that the whole decay measurement shall be repeated for another accelerometer location on the track site. A distance between the two accelerometer locations of about 10 metres is sufficient.

Since the decay rates are a function of the rail pad stiffness and rail-pad materials typically have significant temperature dependence, the temperature of the pad shall be recorded during the measurement.

N.2.2. Measurement system

Each sensor and acquisition system shall have a calibration certificate, according to the prEN ISO 17025:2000 standard ⁽¹⁾.

⁽¹⁾ EN ISO CEI 17025: General requirements for the competence of testing and calibration laboratories, 2000.

The whole measurement system shall be calibrated before and after each series of measurement (and particularly in the case of a modification in the measurement system, acquisition, or measurement location).

N.2.3. Data processing

The total sound power radiated from a rail excited into vibration is the product of the radiation ratio (radiation efficiency) of the rail and the squared velocity amplitude summed over the radiating area. If both vertical and lateral waves in the rail are assumed to decay exponentially from the excitation point (wheel contact) with distance along the rail then, $A(z) \approx A(0)e^{-\beta z}$ where β is the decay constant for the amplitude of the response, A , with distance z along the rail from the excitation point. β can be converted to a decay rate expressed as dB per metre, Δ , as:

$$\Delta = 20 \log_{10}(e^\beta) = 8,686\beta \text{ dB/m.}$$

If A refers to the velocity response then the sound power emitted from the track is proportional to

$$\int_0^{\infty} |A(z)|^2 dz$$

This quantity is simply related to the decay rate, either for vertical or lateral waves, by:

$$\int_0^{\infty} |A(z)|^2 dz = |A(0)|^2 \int_0^{\infty} e^{-2\beta z} dz = |A(0)|^2 \frac{1}{2\beta} \quad (\text{N2.1})$$

This demonstrates the way in which the decay rate is in relation to the noise-radiation performance of the track structure. It shall be expressed as a value in dB/m for each one-third octave frequency band.

The decay rate can, in principle, be evaluated as the slope of a graph of response amplitude in dB versus the distance z . In practice however, it is better to evaluate a decay rate based on a direct estimate of the summed response:

$$\int_0^{\infty} \frac{|A(z)|^2}{|A(0)|^2} dz = \frac{1}{2\beta} \approx \sum_{z=0}^{z_{\max}} \frac{|A(z)|^2}{|A(0)|^2} \Delta z \quad (\text{N2.2})$$

where z_{\max} is the maximum measurement distance and the sum is carried out for the response measurement locations with Δz representing the interval between the mid-distance points to the measurement locations either side. The influence of the interval taken at for the measurement at z_{\max} should be small but is prescribed here to be symmetrical about z_{\max} .

Thus for the response averaged in each one-third octave frequency band, the decay rate is evaluated as:

$$\Delta(\text{in dB/m}) \approx \frac{4,343}{\sum_{z=0}^{z_{\max}} \frac{|A(z)|^2}{|A(0)|^2} \Delta z} \quad (\text{N2.3})$$

It is clear from this that it is immaterial whether A represents the response in terms of acceleration or mobility since these only differ by the factor $2\pi f$, where f is the frequency. The averaging of the spectrum over one-third octave frequency bands may be carried out either before the evaluation of the decay rate for the FRFs or afterwards on the function $\Delta(f)$. Notice that accurate measurement of $A(0)$ is important as it appears as a constant factor in the summation. In fact this is the FRF most easily measured accurately. Experience has shown that there is no significant error introduced by the fact that near-field waves are not taken into account in this simple analysis.

This method of evaluation is robust for high rates of decay but may be subject to error if the practical value of z_{\max} truncates the response in any one-third octave frequency band before a sufficient attenuation has taken place for the summation to z_{\max} to represent a good approximation to the infinite integral. Thus a minimum decay rate that can be evaluated for a particular value of z_{\max} is:

$$\Delta_{\min} = \frac{4,343}{z_{\max}} \quad (\text{N2.4})$$

The evaluated decay rate shall be compared with this value and if it is close to it the estimation of decay rate deemed unsafe. A value of z_{\max} of about 40 m should be capable of evaluating a track decay rate that complies with the minimum specified in Figure N2. However, some in-compliant tracks have significantly lower decay rates in some bands and to avoid the escalation of effort in measurement it may be necessary to resort to line-slope fitting for some bands. In the case of low decay rates, the response data tends to be free from some of the problems indicated above. They shall be checked by plotting them together with the measured FRF versus distance, for each one-third-octave frequency band.

N.2.4. Test report

The spatial TDR (vertical and transversal directions) shall be presented for the third-octave frequency bandwidth, in a graph following the presentation specified in EN ISO 3740:2000 ⁽¹⁾ and IEC 60263:1982 ⁽²⁾ with a scale ratio between horizontal and vertical axes of 3/4, respectively for 1 octave bandwidth and a decay rate of 5 dB/m.

⁽¹⁾ EN ISO 3740: 2000:Acoustic — Determination of sound power levels of noise sources — Guidelines for the use of basic standards.

⁽²⁾ IEC 60263: Scales and sizes for plotting frequency characteristics and polar diagrams.

ANNEX O

Earth Protection of the vehicles' metal parts**O.1. Earthing principles**

All the metal parts of the vehicle:

- Liable to be touched by persons, or possibly by animals, and at risk of becoming a source of excessive contact voltages, as the result of a fault in the vehicles electrical installation or because of parts of the catenary becoming detached, or
- Liable to lead to an accident risk as a result of the arcing of switch-gear subjected to high currents in the presence of dangerous materials,

shall be set at the same potential as the rail through connections having resistances as specified below.

O.2. Earthing of the vehicle bodyshell

The electrical resistance between the metal parts of the rolling stock and the rail shall not exceed 0,05 ohms. These values shall be measured with a current maintained constantly at 50 A with a voltage of 50 V or less.

When the use of materials which are poor conductors of electricity, for example in pivot bearings or axles boxes, does not allow the values specified above to be obtained, the vehicles shall be provided, where applicable, with the following protective earthing connections:

The body to be connected to the frame at least at two different points.

The frame to be connected to each bogie at least once.

Each bogie shall be earthed reliably through at least one wheelset, for example, through the casing of an axle box or by means of an earthing brush.

If there are no bogies, the frame shall be earthed reliably by at least one individual connection for each of the two wheelsets.

Earth connections, permitted to be either bare or insulated, shall be of a flexible material that does not corrode easily, and have a minimum cross-section of 35 mm². If materials other than copper are used, their behaviour in the event of a short circuit shall be equal to or greater than that of 35 mm² of copper, and electrical resistance as laid down above shall not be exceeded under any operating circumstances. These connections shall be mounted in such a way as to be protected from mechanical damage.

O.3. Earthing of the vehicle parts

All conductive elements inside the vehicle, where they might be accessible and connected to metal parts on the roof, shall be bonded to the body of the vehicle in a safe way.

O.4. Earthing of electric installations

All the electrical installations that are connected to the main power circuit, and have metal parts which are likely to be touched and are not switched under power shall have those metal parts bonded with the body of the vehicle in a safe way.

All the metal parts of a vehicle (other than those covered in the previous point) which are susceptible to be touched and, although not switched under power, risk being made live accidentally, shall be bonded in a safe way if the nominal voltage of the part concerned is greater than:

- 50 V direct current
- 24 V alternating current
- 24 V between phases for three phase current where the neutral is not bonded and
- 42 V between phases for three phase current when the neutral is bonded.

The cross-section of earthing bond is a function of current to be conducted; it shall be sized so as to guarantee the safe functioning of the circuit breakers if tripped.

O.5. Aerials

Aerials fitted outside vehicles shall either comply with the following conditions:

- The conductive parts of aerials shall be fully protected from catenary voltages by a protective device made of impact proof insulating material.
 - Aerial systems shall be provided with a single point earth connection (aerial with static earthing);
- or
- Where it is not possible to comply with the previous conditions an aerial fitted outside the vehicle shall be isolated, by means of high voltage capacitors connected to other over-voltage protection devices, connected to the inside of the vehicle.

ANNEX P

Calculation method for decelerations in degraded mode and unfavourable climatic conditions**P.1. Introduction**

This annex describes the procedure that shall be followed to determine the deceleration a_i (m/s^2) for the speed range $[v_{i-1}, v_i]$ in the degraded conditions of case B in table 6 of clause 4.2.4.1 of this TSI and the corresponding maximum stopping distances in Table 7 of clause 4.2.4.7 of this TSI.

The deceleration a_i is permitted to be determined by calculation. This annex describes the method in which every element of the degradation is validated by specific experimental tests.

Alternatively it is permitted to determine the deceleration a_i directly by undertaking tests in the conditions specified for case B. The equivalent time of application shall be verified.

If the use of alternative brake components is allowed on a specific brake system, the worst braking behaviour with respect to the generation of the braking forces and their loss due to humidity shall be taken into account.

P.2. Definition of Tests

The calculation method to assess the decelerations specified in table 6 of clause 4.2.4.1 relies on 4 tests series:

- Series 1: dynamic tests of the train on dry rail, but with brake equipment isolations as defined for case B
- Series 2: dynamic tests of the train on dry rail, all adhesion dependent brakes active and all adhesion independent brakes inactive
- Series 3: dynamic tests of the train in degraded adhesion conditions, all adhesion dependent brakes active and all adhesion independent brakes inactive
- Series 4: rig tests of friction materials in wet conditions

P.2.1. Dynamic tests**P.2.1.1. Test conditions**

- (a) Series 1 emergency braking tests to validate the braking forces as of P.3.1 shall be carried out in the conditions defined for Case B in clause 4.2.4.1 of this TSI for track geometry, load, independent units of the dynamic brake or of the braking system which dissipate kinetic energy through heating the rails, distributor valves.
- (b) Series 2 tests shall be carried out on dry rails and in the same load conditions as series 1.
- (c) Series 3 tests shall be carried out in the same load conditions as series 1 and in the degraded adhesion conditions defined below:

The rails shall be sprayed with an aqueous solution of concentrated detergent of 1 %.

The solution shall be released in front of each wheel of the first axle under a pressure of 0,1 bar to 0,2 bar through a 8mm diameter nozzle, along the longitudinal axis of the rail, a few centimetres from both the rail and the wheel.

The quantity of the liquid shall be doubled for the tests carried out at speeds higher than 160km/h by adding a second nozzle.

The tests shall be conducted in average weather conditions, at moderate ambient temperatures (between 5 °C and 25 °C), and shall not be undertaken in snow. The temperature on the rail surface shall be recorded after every test and shall lie between 5 °C and 35 °C.

Note: The detergent is a solution which contains fatty acids and tensid base elements which total concentration is included between 10 and 15 %, without mineral and biodegradable load.

- (d) For series 1, series 2 and series 3 tests, five braking tests shall be carried out starting from the initial speeds mentioned in Table P.1. The average braking distance S_v^k [m] shall be determined from the five sets of distances for each of the three series.

P.2.1.2. Dynamic test results

Table P.1

List of dynamic tests

	Braking initial speed (km/h)			
	Maximum speed	300	230	170
Series 1 tests	S_{v0}^1	S_{300}^1	S_{230}^1	S_{170}^1
Series 2 tests	S_{v0}^2	S_{300}^2	S_{230}^2	S_{170}^2
Series 3 tests	S_{v0}^3	S_{300}^3	S_{230}^3	S_{170}^3

P.2.1.3. Dynamic tests for adhesion dependant brakes

Each of the series 2 and 3 tests shall be repeated five times from each initial speed as shown in table P.2. The speed and distance shall be recorded for intervals not exceeding one second. The deceleration distances (s [m] for each speed interval $[v_{i-1}, v_i]$ shall be recorded and averaged for the five tests.

Table P.2

List of average values Δs measured during the braking tests

	Series 2 Dry conditions				Series 3 Degraded adhesion			
	Braking initial speed (km/h)				Braking initial speed (km/h)			
Speed interval $[v_{i-1}, v_i]$	Maximum speed	300	230	170	Maximum speed	300	230	170
$V_{max}-300$	$\Delta s_{v0}^2 (1)$	—	—	—	$\Delta s_{v0}^3 (1)$	—	—	—
300-230	$\Delta s_{v0}^2 (2)$	$\Delta s_{300}^2 (2)$	—	—	$\Delta s_{v0}^3 (2)$	$\Delta s_{300}^3 (2)$	—	—
230-170	$\Delta s_{v0}^2 (3)$	$\Delta s_{300}^2 (3)$	$\Delta s_{230}^2 (3)$	—	$\Delta s_{v0}^3 (3)$	$\Delta s_{300}^3 (3)$	$\Delta s_{230}^3 (3)$	—
170-0	$\Delta s_{v0}^2 (4)$	$\Delta s_{300}^2 (4)$	$\Delta s_{230}^2 (4)$	$\Delta s_{170}^2 (4)$	$\Delta s_{v0}^3 (4)$	$\Delta s_{300}^3 (4)$	$\Delta s_{230}^3 (4)$	$\Delta s_{170}^3 (4)$

Note: The first interval Δs at the beginning of the braking process ($\Delta s_{v0}^2 (1)$, $\Delta s_{v0}^2 (2)$, $\Delta s_{v0}^2 (3)$, ... $\Delta s_{v0}^3 (1)$, $\Delta s_{v0}^3 (2)$, ...), shall be reduced by the distance covered during the equivalent time of application (t_e).

P.2.2. Rig tests for determining the effects of reduced friction

Series 4 tests on the braking rig shall be performed to evaluate the efficiency loss of friction brakes in wet conditions.

If a train is equipped with several friction brake types, the rig tests shall be repeated for each type (pad, shoe ...).

The tests shall be done following the process prEN 15 328:2005, annexes A et B (test programmes 1 and 5 as applicable, brake applications 1 to 50). The mean friction coefficients in dry conditions $\mu_{\text{mean_dry}}$ and in humid conditions $\mu_{\text{mean_humid}}$ shall be determined, for the relevant application forces which are closest to those producing the braking forces $F1_{1i}$ of test series 1 in the speed range $[v_{i-1}, v_i]$ (see P.3.1).

P.3. Deceleration Calculations

P.3.1. Determination of braking forces F

The braking forces generated by the brake system are calculated using the series 1 test results. They shall be used to verify the mean braking forces $F1_{1i}$, $F1_{2i}$, $F2_i$ and w_i of each type of brakes in the different speed ranges $[v_{i-1}, v_i]$.

With:

$F1_{1i}$ = braking forces [kN] dependent on friction acting through the wheel/rail contact.

$F1_{2i}$ = other braking forces [kN] acting through the wheel/rail contact.

$F2_i$ = braking forces [kN] that are independent of the wheel/rail contact.

w_i = resistance to forward movement [kN] in the speed range $[v_{i-1}, v_i]$.

P.3.2. Evaluation of k_w — Reduction coefficient due to degraded adhesion

The loss of braking force due to the reduced adhesion shall be calculated based on the values of Table P.2 for every speed interval $[v_{i-1}, v_i]$ using the following formula:

$$k_{w_i} = \text{Minimum} \left(\frac{\Delta s_i^2(k)}{\Delta s_i^3(k)} \right),$$

for $k = 1, \dots, 4$

P.3.3. Evaluation of k_h — Reduction coefficient due to degraded friction

The coefficient k_{h_i} for humidity loss for every speed range $[v_{i-1}, v_i]$ shall be evaluated using the reduced friction coefficients measured during the series 4 rig tests of clause P.2.2. This coefficient k_{h_i} shall be calculated for each friction material and for every speed range $[v_{i-1}, v_i]$ as follows:

Speed interval $[v_{i-1}, v_i]$	Type Pad No 1	Type Pad No 2 if applicable	K_{h_i} for Pads if applicable
$V_{\text{max}}-300$	$k_{h_{1_Pad1}} = \frac{\mu_{\text{mean_humid}}}{\mu_{\text{mean_dry}}}$ μ_{mean} is an open point	$k_{h_{1_Pad2}}$	$k_{h_{1_1}} =$ $\text{Min}(k_{h_{1_Pad1}}; k_{h_{1_Pad2}}; \dots)$
300-230	$k_{h_{2_Pad1}} = \frac{\mu_{\text{mean_humid}}}{\mu_{\text{mean_dry}}}$ μ_{mean} is an open point	$k_{h_{2_Pad2}}$	$k_{h_{2_2}} =$ $\text{Min}(k_{h_{2_Pad1}}; k_{h_{2_Pad2}}; \dots)$
230-170	$k_{h_{3_Pad1}} = \frac{\mu_{\text{mean_humid}}}{\mu_{\text{mean_dry}}}$ μ_{mean} is an open point	$k_{h_{3_Pad2}}$	$k_{h_{3_3}} =$ $\text{Min}(k_{h_{3_Pad1}}; k_{h_{3_Pad2}}; \dots)$
170-0	$k_{h_{4_Pad1}} = \frac{\mu_{\text{mean_humid}}}{\mu_{\text{mean_dry}}}$ μ_{mean} is the average value of the tests at 160 km/h with application forces which are closest to those producing the braking forces of the speed range	$k_{h_{4_Pad2}}$	$k_{h_{4_4}} =$ $\text{Min}(k_{h_{4_Pad1}}; k_{h_{4_Pad2}}; \dots)$

This process shall also be applied for the braking shoes to obtain the coefficient for humidity loss for the brake blocks if they exist on the train.

For class 1 trains, where the maximum speed v_{\max} is lower or equal than 300 km/h the two first speed interval of the table are open points.

For class 2 trains, where the maximum speed v_{\max} is higher or equal to 230km/h, the two first speed intervals are ignored.

For class 2 trains, where the maximum speed v_{\max} is lower than 230km/h, the two first speed intervals are ignored and the speed interval [230-170] is replaced by the range [v_{\max} -170].

P.3.4. Decelerations calculations

The a_i (m/s^2) values shall be calculated using the following formula in the speed range [v_{i-1} , v_i].

$$a_i = \frac{\sum(k_{v_i} \times F_{11i} + k_{w_i} \times F_{12i} + F_{2i}) + w_i}{m_e}$$

where:

- m_e = equivalent mass of the vehicles (including the inertia of therotating mass) [t] resulting from the normal train load as defined in clause 4.2.4.1 of this TSI
- $F_{11i}, F_{12i}, F_{2i}, w_i$ = braking forces defined in P.3.1
- k_{w_i} = coefficient defined in P.3.2.
- k_{h_i} = coefficient defined in P.3.3.
- k_{v_i} = coefficient of braking force reduction on F_{11i} taking into account the humidity effects and the adhesion loss, that is using the minimum values of k_{h_i} and k_{w_i} .

ANNEX Q

Signs indicating the box which contains the resetting equipment of the emergency alarm

Figure Q1

The resetting operation is effected by the Bern key

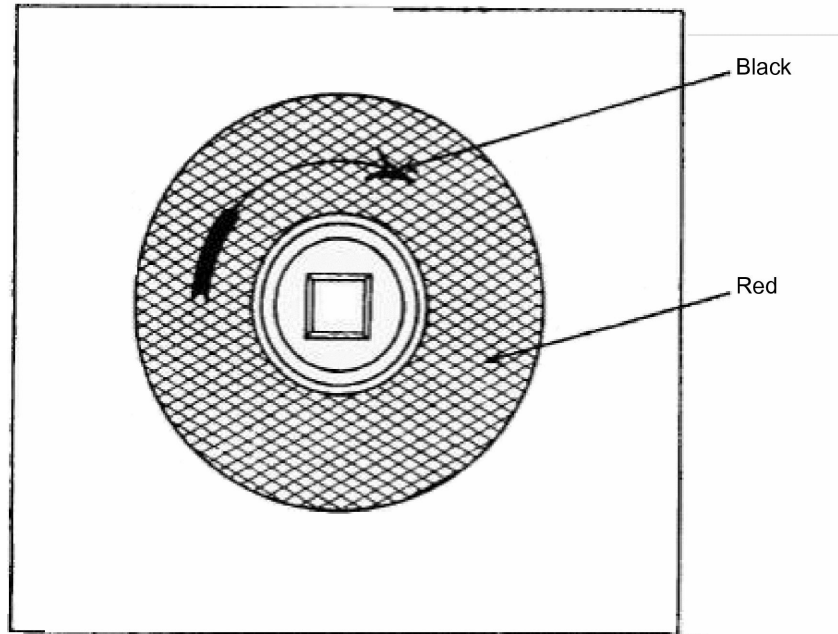
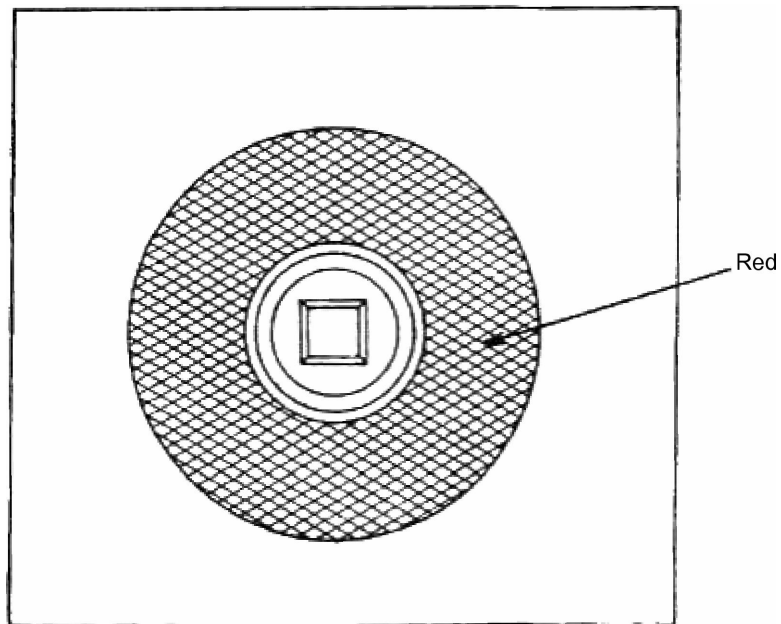

Figure Q2

Resetting requires the box to be opened



ANNEX R

Specific case-Gauge for Finland**FINLAND, STATIC GAUGE FIN1****R.1. General rules**

- 1.1. The vehicle gauge determines the space where the vehicle should be inside when it is in middle position on a straight track. The reference contour (FIN1) is given in Appendix A.
- 1.2. To define the lowest position of the various parts of the vehicle (lower part, parts in the proximity of the flanges) in relation to the track, the displacements hereafter should be considered:
 - Maximum wear
 - Flexibility of suspensions up to the buffers. For grounds which will be made clear, the flexibility of springs has to be taken into account according to the ranking of the UIC Leaflet 505-1.
 - Static deflection of the frame
 - Mounting and construction tolerances
- 1.3. For the definition of the highest location of the various parts of the vehicle, the vehicle is supposed empty, not worn and with mounting and construction tolerances.

R.2. Lower part of the vehicle

The minimum height allowed for the lower parts should be increased according to Appendix B1 for vehicles able to pass over marshalling yard humps and rail brakes.

The vehicles not allowed passing over marshalling yard humps and rail brakes can have a minimum height increased according to Appendix B2.

R.3. Vehicle parts in proximity of the wheel flanges

- 3.1. The minimum vertical distance allowed for vehicle parts located in the vicinity of the wheel flanges, except the wheel themselves, is 55 mm from the running surface. In curves those parts should remain inside the zone occupied by the wheels.

This distance of 55 mm does not apply to the flexible parts of the sanding system or to the flexible brushes.
- 3.2. In exception for the point 3.1, the minimum vertical distance allowed for parts beyond end axles is 125 mm, for vehicles which are retarded by a movable, manually on the rail placed drag shoe.
- 3.3. The minimum distance of brake components which should come in contact with the rail can be smaller than 55 mm from the rail when the components are stationary. They should be located inside the zone between axles and even in curves remain inside the zone occupied by the wheels. The components should not affect operation on shunting devices.

R.4. Vehicle width

- 4.1. Transverse half-width dimensions allowed on straight track and in curve shall be reduced according to Appendix R.C.

R.5. Lower step and access doors opening outwards for coaches and multiple units

- 5.1. The gauge of the lower step of coaches and multiple units is given in Appendix R.D1.
- 5.2. The gauge in open position of access doors opening outwards on coaches and multiple units is given in Appendix R.D2.

R.6. Pantographs and non-insulated live parts on the roof

- 6.1. The lowered pantograph in middle position on a straight track shall not protrude out the vehicle gauge.
- 6.2. The raised pantograph in middle position on a straight track shall not protrude out the vehicle gauge given in Appendix R.E.

The transverse displacements of a pantograph due to oscillations and track inclination and tolerances should be separately taken into account at the time of the installation of the electric line.

- 6.3. If the pantograph is not above the centre of the bogie, the lateral displacement due to the curves should also be taken into account.
- 6.4. Non-insulated parts (25 kV) on the roof should not penetrate the zone indicated in Appendix R.E.

R.7. Rules and later instructions

- 7.1. Besides items R.1-R.6, the vehicles designed for the western traffic also comply with prescriptions of UIC Leaflets 505-1 or 506.

The lower part of the vehicles able to board ferries should later comply with UIC Leaflet 507 (wagons) or 569 (coaches and vans).

- 7.2. Besides items R.1-R.6, the vehicles designed for the traffic with Russia also comply with prescriptions of norm GOST 9238-83. In any case, the usual gauge should be complied with.
 - 7.3. A separate regulation is used for gauging trainsets made up of vehicle with tilting body systems.
 - 7.4. Gauges are dealt with by a separate regulation.
-

Appendix R.A

Vehicle gauge

Figure R.1

Vehicle gauge widening (FIN1)

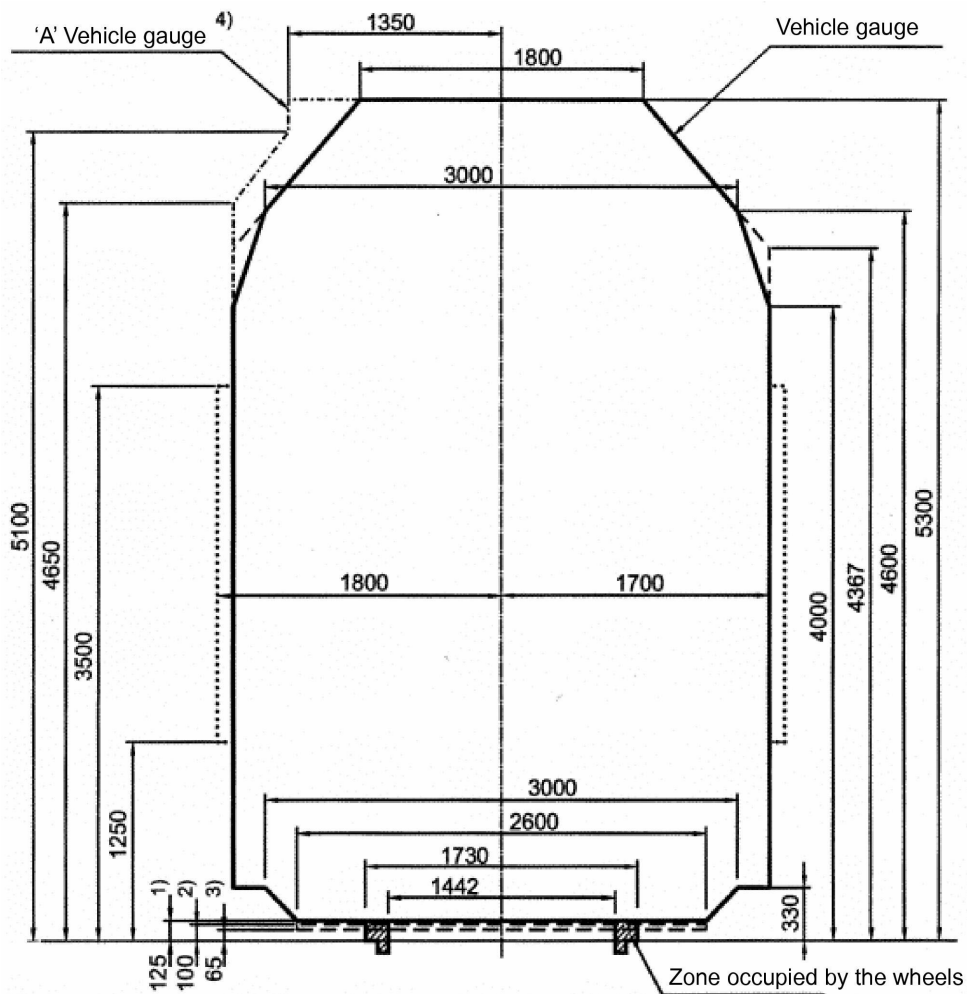

Note: For rear-view mirrors, see Appendix R.D2, item 1, a separate regulation is to be applied for the adoption.

1. Lower part of the vehicles able to pass over marshalling humps and rail brakes.
2. Lower part of the vehicles unable to pass over marshalling humps and rail brakes except for bogies of powered units, see note 3).
3. Lower part of the bogies of powered units unable to pass over marshalling humps and rail brakes.
4. Gauge of the vehicles able to run on lines shown in Jtt (technical specifications related to Finnish Railway's safety standards), where the obstacle gauge has been accordingly widened.

Appendix R.B1

Increase of the minimum height of the lower part of the vehicle able to pass over marshalling humps and rail brakes

The height of the lower part of vehicles should be increased by E_{as} and E_{au} so that:

- if the vehicle runs on the top of a hump, no part between bogie pivots or between end axles could penetrate the running surface of a hump the vertical curvature radius of which is 250 m;
- if the vehicle runs in the concavity of the hump, no part beyond bogie pivots or beyond end axles could penetrate the gauge of rail brakes of a concavity the vertical curvature radius of which is 300 m.

The formulae to (1) to calculate the height increase are (values in metres):

at a distance up to 1,445 m from the centreline of the track:

$$E_{as} = \frac{an - n^2}{500} - h$$

at a distance greater than 1,445 m from the centreline of the track:

$$E_{au} = \frac{an + n^2}{600}$$

$$E_{au} = \frac{an + n^2}{600} - (h - 0,275)$$

Notation:

- E_{as} = height increase of the lower part of the vehicle in cross sections between bogie pivots or between end axles.
 E_{as} should not be taken into account unless its value is positive;
- E_{au} = height increase of the lower part of the vehicle in cross sections beyond bogie pivots or beyond end axles.
 E_{au} should not be taken into account unless its value is positive;
- a = distance between bogie pivots or between end axles;
- n = distance from the cross section considered to the nearest bogie pivot (or the nearest end axle);
- h = height of the lower part of the vehicles above the running surface (see Appendix R.A).

(1) Formulae are based on the position of a rail brake and other shunting devices of marshalling humps shown in Appendix B3.

Appendix R.B2

Increase of the minimum height of the lower part of the vehicle unable to pass over marshalling humps and rail brakes

The height of the lower part of vehicles should be increased by E'_{as} and E'_{au} so that:

- if the vehicle runs over a concave track transition, no part between bogie pivots or between end axles could penetrate the running surface of the track transition the vertical curvature radius of which is 500 m;
- if the vehicle runs over a concave track transition, no part beyond bogie pivots or beyond end axles could penetrate the running surface of the track transition the vertical curvature radius of which is 500 m.

The formulae ⁽¹⁾ to calculate the height increase are (values in metres):

$$E'_{as} = \frac{an - n^2}{1\ 000} - h$$

$$E'_{au} = \frac{an + n^2}{1\ 000} - h$$

Notation:

- E'_{as} = Height increase of the lower part of the vehicle in cross sections between bogie pivots or between end axles.
 E'_{as} should not be taken into account unless its value is positive.
- E'_{au} = Height increase of the lower part of the vehicle in cross sections between bogie pivots or between end axles.
 E'_{au} should not be taken into account unless its value is positive.
- a = distance between bogie pivots or between end axles;
- n = distance from the cross section considered to the nearest bogie pivot (or the nearest end axle)
- h = height of the lower part of the vehicles above the running surface (see Appendix R.A).

⁽¹⁾ Formulae are based on the vehicle gauge for tracks on marshalling humps as shown in Appendix B3.

Appendix R.B3

Location of the rail brakes and other shunting devices of marshalling humps

Figure R.2

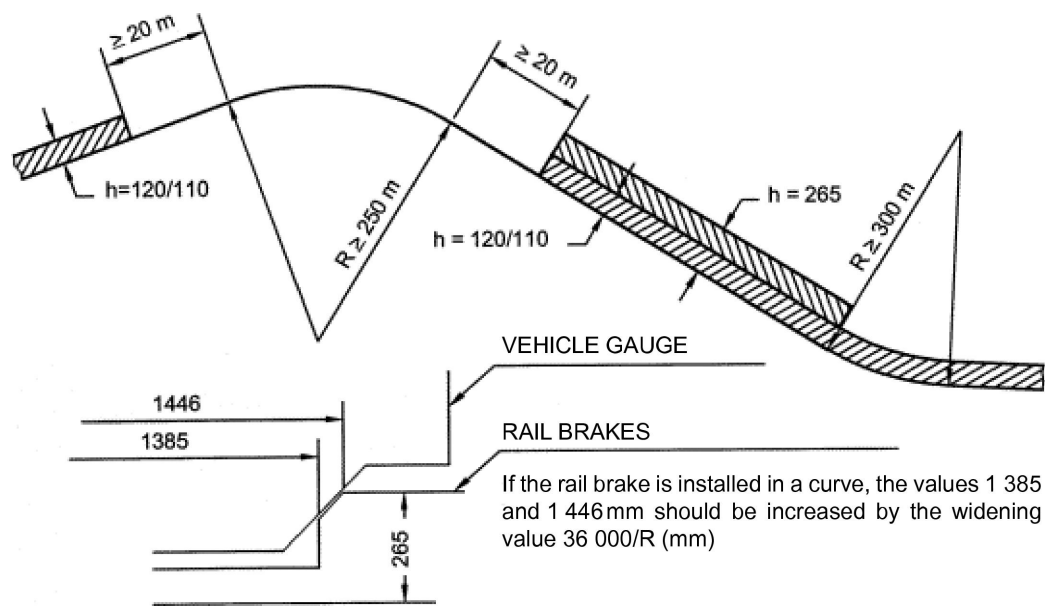
**Passing tracks:**

On the passing tracks of marshalling humps $R_{\min} = 500$ m, and the height of obstacle gauge above the running surface is $h = 0$ mm across the whole vehicle gauge width ($= 1\,700$ mm from track centreline). The longitudinal area where $h = 0$ spreads from the point of 20 m before the convex area on the top of the hump to the point of 20 m after the concave area at the valley of the hump. The obstacle gauge for the marshalling yard is valid outside this area (RAMO item 2.9 and RAMO 2 Annex 2, related to the gauge of marshalling yards, and also RAMO 2 Annex 5 related to the points of crossings).

Appendix R.C

Reduction of the half-width according to the vehicle gauge FIN1, (reduction formulae)

1. General rules

The cross dimensions of the vehicles computed according to the vehicle gauge (Appendix R.A) should be decreased by the quantities E_s or E_u , so that, when the vehicle is in its least favourable position (without inclination on its suspension) and on a track of radius $R = 150$ m, with a track gauge of 1,544 m, no part of the vehicle protrude the half-width of the vehicle gauge FIN1 by more than $(36/R+k)$ from the track centreline.

The centreline of the vehicle gauge coincides with the track centreline, this one being inclined if the track is canted.

Reductions are calculated according to formulae given in chapter 2.

2. Reduction formulae (in metres)

2.1. Sections between bogie pivots or between end axles

$$E_s = \frac{an - n^2}{2R} + \frac{p^2}{8R} + \frac{1-d}{2} + q + w_{iR} - \left(\frac{36}{R} + k \right)$$

$$E_{s\infty} = \frac{1-d}{2} + q + w_{\infty} - k$$

2.2. Sections beyond bogie pivots or beyond end axles (vehicles with a overhang)

$$E_u = \frac{an + n^2}{2R} - \frac{p^2}{8R} + \left(\frac{1-d}{2} + q \right) \frac{2n+a}{a} + w_{iR} \frac{n}{a} + w_{aR} \frac{n+a}{a} - \left(\frac{36}{R} + k \right)$$

$$E_{u\infty} = \left(\frac{1-d}{2} + q + w_{\infty} \right) \frac{2n+a}{a} - k$$

Notations:

- E_s , $E_{s\infty}$ = reduction of the gauge half-width for cross sections between bogie pivots or between end axles. E_s and $E_{s\infty}$ should not be taken into account unless their values are positive;
- E_u , $E_{u\infty}$ = reduction of the gauge half-width for cross sections beyond bogie pivots or beyond end axles. E_u and $E_{u\infty}$ should not be taken into account unless their values are positive;
- a = distance between bogie pivots or between end axles ⁽¹⁾;
- n = distance between the cross section considered and the nearest bogie pivot, or the nearest end axle or the fictional pivot if the vehicle has no fixed pivot;
- p = bogie wheelbase;
- q = is the sum of the play between the axle box and the axle itself and of the possible play between the axle box and the bogie frame measured from the middle position with ultimately worn components;
- w_{iR} = possible transverse displacement of the bogie pivot, and the cradle in relation to the bogie frame or, for vehicles without bogie pivot, possible displacement of the bogie frame in relation to the vehicle frame measured from the middle position towards the internal side of the curve (varies according to the curve radius);
- w_{aR} = as w_{iR} , but towards the outside of the curve;
- w_{∞} = as w_{iR} , but on a straight track, from the middle position and towards both side;

⁽¹⁾ If the vehicle has no actual bogie pivot, a and n should be determined on the base of a fictional pivot located at the intersection of the longitudinal centrelines of the bogie and of the frame, the vehicle being in middle position ($0,026 + q + w = 0$) on a curved track of radius 150 m. If the distance between the pivot calculated by this manner and the bogie centre point is denoted y , the term p^2 should be replaced by $p^2 - y^2$ in reduction formulae.

- l = maximum track gauge in straight and in considered curved track =1,544 m;
- d = distance between ultimately worn wheel flanges, measured 10 mm outwards the running circle =1,492 m;
- R = curve radius;
If w is constant or varies linearly according to 1/R, the radius to be considered is 150 m.
In exceptional cases should be used the value of $R \geq 150$ m, which gives the largest reduction.
- k = allowable gauge protrusion (to be increased by the $36/R$ widening of obstacle gauge) without the inclination due to the suspension flexibility;
0 for $h < 330$ mm for vehicles able to run over rail brakes (see Appendix R.B1),
0,060 m for $h < 600$ mm,
0,075 m for $h \geq 600$ mm.
- h = height above the running surface at the considered location, the vehicle being in its lowest position.

3. Reduction values

The half-width of vehicle cross-sections should be decreased:

3.1. For sections between bogie pivots;

By the greater of values E_s and $E_{s_{\infty}}$.

3.2. For sections beyond bogie pivots;

By the greater of values E_u and $E_{u_{\infty}}$.

Appendix R.D1

Gauge of the vehicle lower step

1. This norm concerns the step used either for high (550/1 800) or for low platforms (265/1 600).

To avoid a uselessly wide gap between the step and the platform edge and taking account of the lower vehicle step and of high platforms (550/1 800 mm), the value 1,700 — E can be exceeded in compliance with Appendix R.C, if a fixed step is concerned. In such a case, the calculations hereafter should be applied which allow checking that, in spite of the protrusion, the step will not reach the platform. The coach should be examined in its lowest position in relation to the running surface.

2. Distance between the track centreline and the platform: $L = 1,800 + \frac{36}{R} - t$

3. Room required for the step:

- 3.1. Step located between bogie pivots: $A_s = B + \frac{an - n^2}{2R} + \frac{p^2}{8R} + \frac{l-d}{2} + q + w_{iR}$

- 3.2. Step located beyond bogie pivots:

$$A_u = B + \frac{an + n^2}{2R} - \frac{p^2}{8R} + \left(\frac{l-d}{2} + q \right) \frac{2n+a}{a} + w_{iR} \frac{n}{a} + w_{aR} \frac{n+a}{a}$$

4. Notations (values in metres):

A_s, A_u	=	distance between the track centreline and the outer edge of a step;
B	=	distance between the vehicle centreline and the outer edge of the step;
a	=	distance between bogie pivots or between end axles;
n	=	distance of the step cross section most remote from the bogie pivot;
p	=	bogie wheel base;
q	=	possible transverse displacement due to the play between the axle and the axle box added with the play between the axle box and the bogie frame measured from the middle position with ultimately worn components;
w_{iR}	=	possible transverse displacement of the bogie pivot and the cradle, measured from the middle position towards the internal side of the curve;
w_{aR}	=	as w_{iR} , but towards the outside of the curve;
$w_{iR/aR}$	=	maximum value in considered curved track (for fixed steps); 0,005 m (for controlled steps which for $v \leq 5$ km/h unfurl automatically);
l	=	maximum track gauge in straight and in considered curved track =1,544 m;
d	=	distance between ultimately worn wheel flanges, measured 10 mm outwards the running circle =1,492 m;
R	=	Curve radius =500 m ... ∞;
t	=	allowed tolerance (0,020 m) for the displacement of the rail towards the platform between two maintenance actions.

5. Rules related to the transverse distance between the step and the platform:

- 5.1. Distance $AV = L - A_{s/u}$ should be at least 0,020 m.

- 5.2. On a straight track, with a coach in its middle position and a platform in its nominal location, a 150 mm distance between vehicle and platform is considered as sufficiently small. Anyway the smallest value should be sought for this distance. In the opposite case, the check is made on a straight and on a curved track where $A_{s/u}$ is maximum.

6. Gauge check

Gauge check for the lower steps should be carried out on a straight track and on a 500 m curve, if value w is constant or varies linearly according to $1/R$. Otherwise, the check should be carried out on a straight track and on curve where $A_{s/u}$ is maximum.

7. Display of the outputs

Formulae used, inserted and resulting values should be displayed in an easily understood manner.

Appendix R.D2

Gauge of outwards opening doors and of opened steps for coaches and multiple units

1. To avoid a uselessly wide gap between the step and the platform edge, the value 1,700 — E (see UIC Leaflet 560 § 1.1.4.2) can be exceeded in compliance with Appendix R.C, in the design of an outwards opening door with a step in open or closed position, or when the door and the step are moving between open and closed positions. In this case the checks hereafter should be carried out, among others to evidence that, in spite of the additional displacement, neither the door nor the step interfere with the fixed equipment (RAMO item 2.9 Annex 2). In the calculations the coach should be examined in its lowest position in relation to the running surface.

Hereafter, the word door includes the step as well.

NOTE: Appendix R.D2 may also be used to check the outer rear-view mirror of a loco and motor car the mirror being in open position. During normal line traffic the mirror is closed in a position recessed inside the body gauge.

2. The distance between the track centreline and the fixed equipment is: $L = AT + \frac{36}{R} - t$;

AT = 1,800 m when $h < 600$ mm,

AT = 1,920 m when $600 < h \leq 1\,300$ mm,

AT = 2,000 m when $h > 1\,300$ mm.

3. Room required for to the door:

- 3.1. Door located between bogie pivots:

$$O_s = B + \frac{an - n^2}{2R} + \frac{p^2}{8R} + \frac{l-d}{2} + q + w_{iR}$$

- 3.2. Door located beyond bogie pivots:

$$O_u = B + \frac{an + n^2}{2R} - \frac{p^2}{8R} + \left(\frac{l-d}{2} + q \right) \frac{2n+a}{a} + w_{iR} \frac{n}{a} + w_{aR} \frac{n+a}{a}$$

Notation (values in metres):

- AT = nominal distance between the track centreline and the fixed equipment (on a straight track);
- h = height above the running surface at the considered location, the vehicle being in its lowest position;
- O_s, O_u = distance allowed between the track centreline and the door edge, when the door is in its most protruding position;
- B = distance between the vehicle centreline and the door edge, when the door is in its most protruding position;
- a = distance between bogie pivots or between end axles;
- n = distance of the door cross section most remote from the bogie pivot;
- p = bogie wheel base;
- q = possible transverse displacement due to the play between the axle and the axle box added with the play between the axle box and the bogie frame measured from the middle position with ultimately worn components;
- w_{iR} = possible transverse displacement of the bogie pivot and the cradle, measured from the middle position towards the internal side of the curve;
- w_{aR} = as w_{iR}, but towards the outside of the curve;
- w_{iR/aR} = 0,020 m, maximum value for speeds less than 30 km/h (UIC 560);
- l = maximum track gauge in straight and in considered curved track = 1,544 m;
- d = distance between ultimately worn wheel flanges, measured 10mm outwards the running circle = 1,492 m

- R = Curve radius:
for $h < 600$ mm, $R = 500$ m,
for $h \geq 600$ mm, $R = 150$ m.
- t = allowed tolerance (0,020 m) for the displacement of the rail towards the fixed equipment between two maintenance actions.

4. Rules related to the transverse distance between the door and the fixed equipment:

Distance $OV = L - O_{s/u}$ should be at least 0,020 m.

5. Gauge check

Door gauge check should be carried out on a straight track and on a 500/150-m curve, if value w varies linearly according to $1/R$. Otherwise, the check should be carried out on a straight track and on curve where $O_{s/u}$ is maximum.

6. Display of the outputs

Formulae used, inserted and resulting values should be displayed in an easily understood manner.

Appendix R.E

Pantograph and non-insulated live parts

Figure R.3

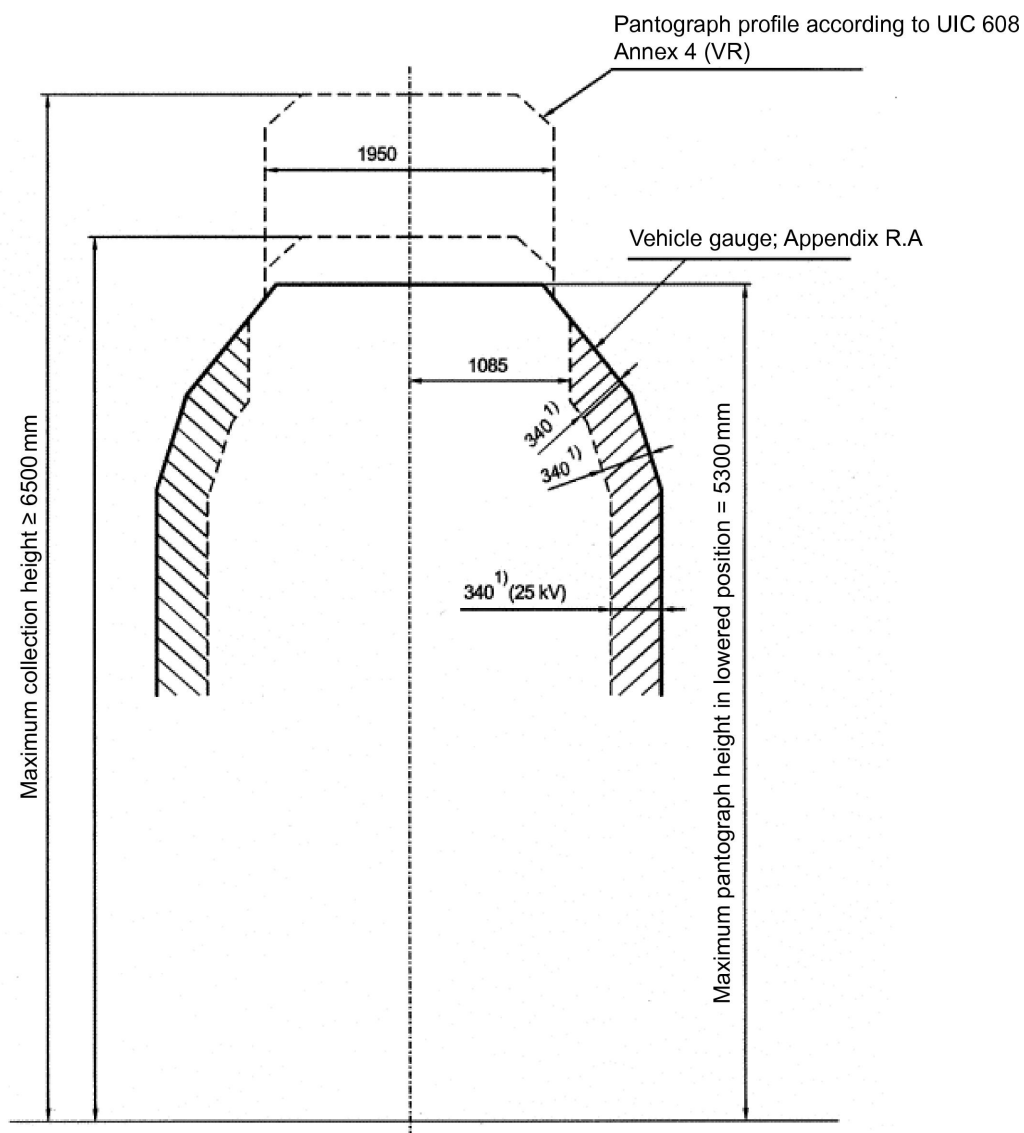

Any non-insulated live part shall not be placed in the shaded area (25 kV).

1. E_s or E_u shall be added in the transversal direction according to Appendix R.C.

CORRIGENDA**Corrigendum to the Guideline of the European Central Bank of 1 August 2007 on monetary, financial institutions and markets statistics (recast)***(ECB/2007/9)**(Official Journal L 341, 27 December 2007)*

On page 178, Annex III, part 14, table 1 is replaced by the following table:

