

# Official Journal

## of the European Union

L 216

Volume 47

English edition

Legislation

16 June 2004

Contents

I Acts whose publication is obligatory

.....

II Acts whose publication is not obligatory

.....

Notice to readers ..... 1

### Corrigenda

- ★ **Corrigendum to Commission Directive 2004/73/EC of 29 April 2004 adapting to technical progress for the 29th time Council Directive 67/548/EEC on the approximation of the laws, regulations and administrative provisions relating to the classification, packaging and labelling of dangerous substances (OJ L 152 of 30.4.2004)..... 3**

Price: EUR 46



Acts whose titles are printed in light type are those relating to day-to-day management of agricultural matters, and are generally valid for a limited period.

The titles of all other Acts are printed in bold type and preceded by an asterisk.

- ES:** El presente Diario Oficial se publica en español, danés, alemán, griego, inglés, francés, italiano, neerlandés, portugués, finés y sueco.  
Las correcciones de errores que contiene se refieren a los actos publicados con anterioridad a la ampliación de la Unión Europea del 1 de mayo de 2004.
- CS:** Tento Úřední věstník se vydává ve španělštině, dánštině, němčině, řečtině, angličtině, francouzštině, italštině, holan-  
dštině, portugalštině, finštině a švédštině.  
Tisková oprava zde uvedená se vztahuje na akty uveřejněné před rozšířením Evropské unie dne 1. května 2004.
- DA:** Denne EU-Tidende offentliggøres på dansk, engelsk, finsk, fransk, græsk, italiensk, nederlandsk, portugisisk, spansk,  
svensk og tysk.  
Berigtigelserne heri henviser til retsakter, som blev offentliggjort før udvidelsen af Den Europæiske Union den 1. maj  
2004.
- DE:** Dieses Amtsblatt wird in Spanisch, Dänisch, Deutsch, Griechisch, Englisch, Französisch, Italienisch, Niederländisch,  
Portugiesisch, Finnisch und Schwedisch veröffentlicht.  
Die darin enthaltenen Berichtigungen beziehen sich auf Rechtsakte, die vor der Erweiterung der Europäischen Union  
am 1. Mai 2004 veröffentlicht wurden.
- ET:** Käesolev Euroopa Liidu Teataja ilmub hispaania, taani, saksa, kreeka, inglise, prantsuse, itaalia, hollandi, portugali,  
soome ja rootsi keeles.  
Selle parandused viitavad aktidele, mis on avaldatud enne Euroopa Liidu laienemist 1. mail 2004.
- EL:** Η παρούσα Επίσημη Εφημερίδα δημοσιεύεται στην ισπανική, δανική, γερμανική, ελληνική, αγγλική, γαλλική, ιταλική, ολλαν-  
δική, πορτογαλική, φινλανδική και σουηδική γλώσσα.  
Τα διορθωτικά που περιλαμβάνει αναφέρονται σε πράξεις που δημοσιεύθηκαν πριν από τη διεύρυνση της Ευρωπαϊκής  
Ένωσης την 1η Μαΐου 2004.
- EN:** This Official Journal is published in Spanish, Danish, German, Greek, English, French, Italian, Dutch, Portuguese,  
Finnish and Swedish.  
The corrigenda contained herein refer to acts published prior to enlargement of the European Union on 1 May  
2004.
- FR:** Le présent Journal officiel est publié dans les langues espagnole, danoise, allemande, grecque, anglaise, française, ita-  
lienne, néerlandaise, portugaise, finnoise et suédoise.  
Les rectificatifs qu'il contient se rapportent à des actes publiés antérieurement à l'élargissement de l'Union  
européenne du 1<sup>er</sup> mai 2004.
- IT:** La presente Gazzetta ufficiale è pubblicata nelle lingue spagnola, danese, tedesca, greca, inglese, francese, italiana,  
olandese, portoghese, finlandese e svedese.  
Le rettifiche che essa contiene si riferiscono ad atti pubblicati anteriormente all'allargamento dell'Unione europea del  
1° maggio 2004.
- LV:** Šis Oficiālais Vēstnesis publicēts spāņu, dāņu, vācu, grieķu, angļu, franču, itāļu, holandiešu, portugāļu, somu un zvie-  
dru valodā.  
Šeit minētie labojumi attiecas uz tiesību aktiem, kas publicēti pirms Eiropas Savienības paplašināšanās 2004. gada 1.  
maijā.
- LT:** Šis Oficialusis leidinys išleistas ispanų, danų, vokiečių, graikų, anglų, prancūzų, italų, olandų, portugalų, suomių ir  
švedų kalbomis.  
Čia išspausdintas teisės aktų, paskelbtų iki Europos Sąjungos plėtros gegužės 1 d., klaidų ištaisymas.
- HU:** Ez a Hivatalos Lap spanyol, dán, német, görög, angol, francia, olasz, holland, portugál, finn és svéd nyelven jelenik  
meg.  
Az itt megjelent helyesbítések elsősorban a 2004. május 1-jei európai uniós bővítéssel kapcsolatos jogszabályokra  
vonatkoznak.
- MT:** Dan il-Ġurnal Uffiċjali hu ppubblikat fil-ligwa Spanjola, Daniża, Ġermaniża, Griega, Ingliża, Franċiża, Taljana, Olan-  
diża, Portugiża, Finlandiża u Svediża.  
Il-corrigenda li tinstab hawnhekk tirreferi għal atti ppubblikati qabel it-tkabbir ta' l-Unjoni Ewropea fl-1 ta' Mejju  
2004.

- NL:** Dit Publicatieblad wordt uitgegeven in de Spaanse, de Deens, de Duitse, de Griekse, de Engelse, de Franse, de Italiaanse, de Nederlandse, de Portugese, de Finse en de Zweedse taal.  
De rectificaties in dit Publicatieblad hebben betrekking op besluiten die vóór de uitbreiding van de Europese Unie op 1 mei 2004 zijn gepubliceerd.
- PL:** Ten Dziennik Urzędowy jest wydawany w językach: hiszpańskim, duńskim, niemieckim, greckim, angielskim, francuskim, włoskim, niderlandzkim, portugalskim, fińskim i szwedzkim.  
Sprostowania zawierają odniesienia do aktów opublikowanych przed rozszerzeniem Unii Europejskiej dnia 1 maja 2004 r.
- PT:** O presente Jornal Oficial é publicado nas línguas espanhola, dinamarquesa, alemã, grega, inglesa, francesa, italiana, neerlandesa, portuguesa, finlandesa e sueca.  
As rectificações publicadas neste Jornal Oficial referem-se a actos publicados antes do alargamento da União Europeia de 1 de Maio de 2004.
- SK:** Tento úradný vestník vychádza v španielskom, dánskom, nemeckom, gréckom, anglickom, francúzskom, talianskom, holandskom, portugalskom, fínskom a švédskom jazyku.  
Korigendá, ktoré obsahuje, odkazujú na akty uverejnené pred rozšírením Európskej únie 1. mája 2004.
- SL:** Ta Uradni list je objavljen v španskem, danskem, nemškem, grškem, angleškem, francoskem, italijanskem, nizozemskem, portugalskem, fnskem in švedskem jeziku.  
Vsebovani popravki se nanašajo na akte objavljene pred širitvijo Evropske unije 1. maja 2004
- FI:** Tämä virallinen lehti on julkaistu espanjan, tanskan, saksan, kreikan, englannin, ranskan, italian, hollannin, portugalin, suomen ja ruotsin kielellä.  
Lehden sisältämät oikaisut liittyvät ennen Euroopan unionin laajentumista 1. toukokuuta 2004 julkaistuihin säädöksiin.
- SV:** Denna utgåva av Europeiska unionens officiella tidning publiceras på spanska, danska, tyska, grekiska, engelska, franska, italienska, nederländska, portugisiska, finska och svenska.  
Rättelserna som den innehåller avser rättsakter som publicerades före utvidgningen av Europeiska unionen den 1 maj 2004.

## CORRIGENDA

**Corrigendum to Commission Directive 2004/73/EC of 29 April 2004 adapting to technical progress for the 29th time Council Directive 67/548/EEC on the approximation of the laws, regulations and administrative provisions relating to the classification, packaging and labelling of dangerous substances**

*(‘Official Journal of the European Union’ L 152 of 30 April 2004)*

Directive 2004/73/EC should read as follows:

**‘COMMISSION DIRECTIVE 2004/73/EC**

**of 29 April 2004**

**adapting to technical progress for the 29th time Council Directive 67/548/EEC on the approximation of the laws, regulations and administrative provisions relating to the classification, packaging and labelling of dangerous substances**

*(Text with EEA relevance)*

THE COMMISSION OF THE EUROPEAN COMMUNITIES,

Having regard to the Treaty establishing the European Community,

Having regard to Council Directive 67/548/EEC of 27 June 1967 on the approximation of the laws, regulations and administrative provisions relating to the classification, packaging and labelling of dangerous substances <sup>(1)</sup>, and in particular Article 28 thereof,

Whereas:

- (1) Annex I to Directive 67/548/EEC contains a list of dangerous substances, together with particulars of the classification and labelling of each substance. That list needs to be updated to include further notified new substances and further existing substances as well as adapting the existing entries to technical progress such as setting environmental concentration limits for certain substances. Accordingly it is also necessary to delete entries for certain substances and to split some entries because the classification no longer applies to all the substances under those entries. The labelling of substances containing 1,3-butadiene should be changed in order to reflect that that substance will be classified as a mutagen by the present Directive.
- (2) Annex V to Directive 67/548/EEC lays down the methods for the determination of the physicochemical properties, toxicity and ecotoxicity of substances and preparations. It is appropriate to amend that Annex in order to obtain a reduction to a minimum of the number of animals used for experimental purposes, in accordance with Council Directive 86/609/EEC of 24 November 1986 on the approximation of laws, regulations and administrative provisions of the Member States regarding

the protection of animals used for experimental and other scientific purposes <sup>(2)</sup>. The methods for subchronic oral toxicity in Chapters B.1, B.4, B.5, B.31 and B.35 should be revised accordingly. Furthermore, Chapter B.42 should be added to Annex V in order to make available a refined method on subchronic oral toxicity. Finally, Chapter A.21 on physico-chemical properties, Chapter B.43 on subchronic oral toxicity and Chapters C.21 to C.24 on environmental toxicity should be added in order to allow for the determination of properties which are not yet sufficiently covered by the methods in Annex V.

- (3) The measures provided for in this Directive are in accordance with the opinion of the Committee on the Adaptation to Technical Progress of the Directives for the Elimination of Technical Barriers to Trade with Dangerous Substances and Preparations,

HAS ADOPTED THIS DIRECTIVE:

*Article 1*

Directive 67/548/EEC is amended as follows:

1. Annex I is amended as follows:

- (a) note K in the foreword is replaced by the text set out in Annex 1A;

<sup>(1)</sup> OJ 196, 16.8.1967, p. 1. Directive as last amended by Regulation (EC) No 807/2003 (OJ L 122, 16.5.2003, p. 36).

<sup>(2)</sup> OJ L 358, 18.12.1986, p. 1. Directive as last amended by Directive 2003/65/EC of the European Parliament and of the Council (OJ L 230, 16.9.2003, p. 32).



- (b) the entries corresponding to the entries set out in Annex 1B to this Directive are replaced by the text set out in that Annex;
- (c) the entries set out in Annex 1C to this Directive are inserted in accordance with the order of the entries set out in Annex I to Directive 67/548/EEC;
- (d) the entries with index numbers 604-050-00-X, 607-050-00-8, 607-171-00-6 and 613-130-00-3 are deleted;
- (e) the entry with index number 048-002-00-0 is replaced by the entries with index numbers 048-002-00-0 and 048-011-00-X set out in Annex 1D to this Directive;
- (f) the entry with index number 609-006-00-3 is replaced by the entries with index numbers 609-006-00-3 and 609-065-00-5 set out in Annex 1D to this Directive;
- (g) the entry with index number 612-039-00-6 is replaced by the entries with index numbers 612-039-00-6 and 612-207-00-9 as set out in Annex 1D.
2. Annex V is amended as follows:
- (a) the text set out in Annex 2A to this Directive is added as Chapter A.21;
- (b) chapter B.1 bis is replaced by the text set out in Annex 2B to this Directive;
- (c) chapter B.1 tris is replaced by the the text set out in Annex 2C to this Directive;
- (d) chapter B.4 is replaced by the text set out in Annex 2D to this Directive;
- (e) chapter B.5 is replaced by the text set out in Annex 2E to this Directive;
- (f) chapter B.31 is replaced by the text set out in Annex 2F to this Directive;
- (g) chapter B.35 is replaced by the text set out in Annex 2G to this Directive;
- (h) the text set out in Annex 2H to this Directive is added as Chapter B.42 and B.43;
- (i) the text set out in Annex 2I to this Directive is added as Chapter C.21 to C.24.

#### Article 2

1. Member States shall bring into force the laws, regulations and administrative provisions necessary to comply with this Directive by 31 October 2005 at the latest. They shall forthwith communicate to the Commission the text of those provisions and a correlation table between those provisions and this Directive. When Member States adopt those provisions, they shall contain a reference to this Directive or be accompanied by such a reference on the occasion of their official publication. Member States shall determine how such reference is to be made.

2. Member States shall communicate to the Commission the main provisions of national law which they adopt in the field covered by this Directive.

#### Article 3

This Directive shall enter into force on the twentieth day following its publication in the *Official Journal of the European Union*.

#### Article 4

This Directive is addressed to the Member States.

Done at Brussels, 29 April 2004.

For the Commission

Margot WALLSTRÖM

Member of the Commission

## ANNEX 1A

## Note K:

The classification as a carcinogen or mutagen need not apply if it can be shown that the substance contains less than 0.1 % w/w 1,3-butadiene (Einecs No 203-450-8). If the substance is not classified as a carcinogen or mutagen, at least the S-phrases (2-)9-16 should apply. This note applies to certain complex oil-derived substances in Annex I.

---

## ANNEX 1B

| Index No      | chemical name  | Notes related to substances | EC No     | CAS No     | Classification  | Labelling   | Concentration Limits   | Notes related to preparations |
|---------------|--|-----------------------------|-----------|------------|---|---|--|-------------------------------|
| '006-005-00-4 | thiram<br>tetramethylthiuram disulphide                            |                             | 205-286-2 | 137-26-8   | Xn; R20/22-48/22<br>Xi; R36/38<br>R43<br>N; R50-53  | Xn; N<br>R: 20/22-36/38-43-48/<br>22-50/53<br>S: (2-)26-36/37-60-61                   | C ≥ 25 %: Xn, N; R20/22-36/38-43-48/<br>22-50/53<br>20 % ≤ C < 25 %: Xn, N; R36/38-43-48/<br>22-50/53<br>10 % ≤ C < 20 %: Xn, N; R43-48/22-50/<br>53<br>2,5 % ≤ C < 10 %: Xi, N; R43-50/53<br>1 % ≤ C < 2,5 %: Xi, N; R43-51/53<br>0,25 % ≤ C < 1 %: N; R51/53<br>0,025 % ≤ C < 0,25 %: R52/53   |                               |
| 006-006-01-7  | hydrogen cyanide ...%<br>hydrocyanic acid ...%                     | B                           | 200-821-6 | 74-90-8    | T+; R26/27/28<br>N; R50-53  | T+; N<br>R: 26/27/28-50/53<br>S: (1/2-)7/9-16-36/37-<br>38-45-60-61                   | C ≥ 25 %: T+, N; R26/27/28-50-53<br>7 % ≤ C < 25 %: T+, N; R26/27/28-51-53<br>2,5 % ≤ C < 7 %: T, N; R23/24/25-51-53<br>1 % ≤ C < 2,5 %: T, N; R23/24/25-52-53<br>0,25 % ≤ C < 1 %: Xn; R20/21/22-52-53<br>0,1 % ≤ C < 0,25 %: Xn; R20/21/22   |                               |
| 006-012-00-2  | ziram (ISO)<br>zinc bis<br>dimethyldithiocarbamate                 |                             | 205-288-3 | 137-30-4   | T+; R26<br>Xn; R22-48/22<br>Xi; R37-41<br>R43<br>N; R50-53                                | T+; N<br>R: 22-26-37-41-43-48/<br>22-50/53<br>S: (1/2-)22-26-28-36/37/<br>39-45-60-61 | C ≥ 25 %: T+, N; R22-26-37-41-43-48/<br>22-50-53<br>20 % ≤ C < 25 %: T+, N; R26-37-41-43-<br>48/22-50-53<br>10 % ≤ C < 20 %: T+, N; R26-41-43-48/<br>22-50-53<br>7 % ≤ C < 10 %: T+, N; R26-36-43-50-53<br>5 % ≤ C < 7 %: T, N; R23-36-43-50-53<br>1 % ≤ C < 5 %: T, N; R23-43-50-53<br>0,25 % ≤ C < 1 %: Xn, N; R20-50-53<br>0,1 % ≤ C < 0,25 %: Xn, N; R20-51-53<br>0,025 % ≤ C < 0,1 %: N; R51-53<br>0,0025 % ≤ C < 0,025 %: R52-53 |                               |
| 006-021-00-1  | linuron (ISO)<br>3-(3,4-dichlorophenyl)-1-<br>methoxy-1-methylurea | E                           | 206-356-5 | 330-55-2   | Repr. Cat. 2; R61<br>Repr. Cat. 3; R62<br>Carc. Cat. 3; R40<br>Xn; R22-48/22<br>N; R50-53 | T; N<br>R: 61-22-40-48/22-62-<br>50/53<br>S: 53-45-60-61                              |  |                               |
| 006-044-00-7  | isoproturon<br>3-(4-isopropylphenyl)-1,1-<br>dimethylurea          |                             | 251-835-4 | 34123-59-6 | Carc. Cat. 3; R40<br>N; R50-53  | Xn; N<br>R: 40-50/53<br>S: (2-)36/37-60-61  | C ≥ 2,5 %: Xn, N; R40-50-53<br>1 % ≤ C < 2,5 %: Xn, N; R40-51-53<br>0,25 % ≤ C < 1 %: N; R51-53<br>0,025 % ≤ C < 0,25 %: R52-53  |                               |

| Index No     | chemical name                                   | Notes related to substances | EC No     | CAS No     | Classification   | Labelling  | Concentration Limits  | Notes related to preparations |
|--------------|---|-----------------------------|-----------|------------|--|--|---|-------------------------------|
| 006-072-00-X | S-benzyl N,N-dipropylthiocarbamate prosulfocarb |                             | 401-730-6 | 52888-80-9 | Xn; R22<br>R43<br>N; R51-53  | Xn; N<br>R: 22-43-51/53<br>S: (2-)24-37-61                         |   |                               |
| 006-089-00-2 | chlorine dioxide                                |                             | 233-162-8 | 10049-04-4 | O; R8<br>R6<br>T+; R26<br>C; R34<br>N; R50                             | O; T+; N<br>R: 6-8-26-34-50<br>S: (1/2-)23-26-28-36/37/39-38-45-61 | C ≥ 5 %: T+; N; R26-34-50<br>1 % ≤ C < 5 %: T+; N; R26-36/37/38-50<br>0,5 % ≤ C < 1 %: T; N; R23-36/37/38-50<br>0,2 % ≤ C < 0,5 %: T; N; R23-50<br>0,02 % ≤ C < 0,2 %: Xn; N; R20-50  |                               |
| 006-089-01-X | chlorine dioxide ... %                          | B                           | 233-162-8 | 10049-04-4 | T; R25<br>C; R34<br>N; R50   | T; N<br>R: 25-34-50<br>S: (1/2-)23-26-28-36/37/39-45-61            | C ≥ 25 %: T; N; R25-34-50<br>10 % ≤ C < 25 %: C; N; R22-34-50<br>3 % ≤ C < 10 %: Xn; N; R22-36/37/38-50<br>0,3 % ≤ C < 3 %: Xi; R36   |                               |
| 007-001-00-5 | ammonia, anhydrous                              |                             | 231-635-3 | 7664-41-7  | R10<br>T; R23<br>C; R34<br>N; R50                                      | T; N<br>R: 10-23-34-50<br>S: (1/2-)9-16-26-36/37/39-45-61          | C ≥ 25 %: T; N; R23-34-50<br>5 % ≤ C < 25 %: T; R23-34<br>0,5 % ≤ C < 5 %: Xn; R20-36/37/38   |                               |
| 007-008-00-3 | hydrazine                                       | E                           | 206-114-9 | 302-01-2   | R10<br>Carc. Cat. 2; R45<br>T; R23/24/25<br>C; R34<br>R43<br>N; R50-53 | T; N<br>R: 45-10-23/24/25-34-43-50/53<br>S: 53-45-60-61            | C ≥ 25 %: T; N; R45-23/24/25-34-43-50/53<br>10 % ≤ C < 25 %: T; N; R45-20/21/22-34-43-51/53<br>3 % ≤ C < 10 %: T; N; R45-20/21/22-36/38-43-51/53<br>2,5 % ≤ C < 3 %: T; N; R45-43-51/53<br>1 % ≤ C < 2,5 %: T; R45-43-52/53<br>0,25 % ≤ C < 1 %: T; R45-52/53<br>0,1 % ≤ C < 0,25 %: T; R45 |                               |
| 007-010-00-4 | sodium nitrite                                  |                             | 231-555-9 | 7632-00-0  | O; R8<br>T; R25<br>N; R50  | O; T; N<br>R: 8-25-50<br>S: (1/2-)45-61                            | C ≥ 25 %: T; N; R25-50<br>5 % ≤ C < 25 %: T; R25<br>1 % ≤ C < 5 %: Xn; R22  |                               |
| 007-011-00-X | potassium nitrite                               |                             | 231-832-4 | 7758-09-0  | O; R8<br>T; R25<br>N; R50  | O; T; N<br>R: 8-25-50<br>S: (1/2-)45-61                            | C ≥ 25 %: T; N; R25-50<br>5 % ≤ C < 25 %: T; R25<br>1 % ≤ C < 5 %: Xn; R22  |                               |
| 007-013-00-0 | 1,2-dimethylhydrazine                           | E                           | —         | 540-73-8   | Carc. Cat. 2; R45<br>T; R23/24/25<br>N; R51-53                         | T; N<br>R: 45-23/24/25-51/53<br>S: 53-45-61                        | C ≥ 25 %: T; N; R45-23/24/25-51/53<br>3 % ≤ C < 25 %: T; R45-20/21/22-52/53<br>2,5 % ≤ C < 3 %: T; R45-52/53<br>0,01 % ≤ C < 2,5 %: T; R45  |                               |

| Index No     | chemical name   | Notes related to substances | EC No     | CAS No    | Classification   | Labelling   | Concentration Limits  | Notes related to preparations |
|--------------|---|-----------------------------|-----------|-----------|--|---|---|-------------------------------|
| 007-017-00-2 | isobutyl nitrite  | E                           | 208-819-7 | 542-56-3  | F; R11<br>Xn; R20/22<br>Carc. Cat. 2; R45<br>Muta. Cat. 3; R68 | F; T<br>R: 11-20/22-45-68<br>S: 53-45                                 |   |                               |
| 007-027-00-7 | 1,6-bis(3,3-bis((1-methylpentylidenedimino)propyl)ureido)hexane                         |                             | 420-190-2 | —         | Xn; R21/22-48/21<br>C; R34<br>R43<br>N; R50-53                 | C; N<br>R: 21/22-34-43-48/21-50/53<br>S: (1/2-)7-26-36/37/39-45-60-61 |   |                               |
| 008-003-00-9 | hydrogen peroxide solution ... %  | B                           | 231-765-0 | 7722-84-1 | R5<br>O; R8<br>C; R35<br>Xn; R20/22                            | O; C<br>R: 5-8-20/22-35<br>S: (1/2-)17-26-28-36/37/39-45              | C ≥ 70 %: C; R20/22-35<br>50 % ≤ C < 70 %: C; R20/22-34<br>35 % ≤ C < 50 %: Xn; R22-37/38-41<br>8 % ≤ C < 35 %: Xn; R22-41<br>5 % ≤ C < 8 %: Xi; R36<br>Footnote:<br>C ≥ 70 %: R5, O;R8<br>50 % ≤ C < 70 %: O; R8 |                               |
| 009-015-00-7 | sulphuryl difluoride  |                             | 220-281-5 | 2699-79-8 | T; R23<br>Xn; R48/20<br>N; R50                                 | T; N<br>R: 23-48/20-50<br>S: (1/2-)45-63-60-61                        |   |                               |
| 015-002-00-7 | red phosphorus  |                             | 231-768-7 | 7723-14-0 | F; R11<br>R16<br>R52-53  | F<br>R: 11-16-52/53<br>S: (2-)7-43-61                                 |   |                               |
| 015-014-00-2 | tributyl phosphate  |                             | 204-800-2 | 126-73-8  | Carc.Cat.3; R40<br>Xn; R22<br>Xi; R38                          | Xn<br>R: 22-38-40<br>S: (2-)36/37-46                                  |   |                               |
| 015-015-00-8 | tricresyl phosphate<br>tritoyl phosphate<br>o-o-o, o-o-m, o-o-p, o-m-m,<br>o-m-p, o-p-p | C                           | 201-103-5 | 78-30-8   | T; R39/23/24/25<br>N; R51-53                                   | T; N<br>R: 39/23/24/25-51/53<br>S: (1/2-)20/21-28-45-61               | C ≥ 25 %: T, N; R39/23/24/25-51/53<br>2,5 % ≤ C < 25 %: T; R39/23/24/25-52/53<br>1 % ≤ C < 2,5 %: T; R39/23/24/25<br>0,2 % ≤ C < 1 %: Xn; R68/20/21/22  |                               |

| Index No     | chemical name  | Notes related to substances | EC No     | CAS No    | Classification              | Labelling  | Concentration Limits  | Notes related to preparations |
|--------------|--|-----------------------------|-----------|-----------|-----------------------------|--|---|-------------------------------|
| 015-016-00-3 | tricresyl phosphate<br>tritolyl phosphate<br>m-m-m, m-m-p, m-p-p, p-p-p    | C                           | 201-105-6 | 78-32-0   | Xn; R21/22<br>N; R51-53     | Xn; N<br>R: 21/22-51/53<br>S: (2-)28-61                  | C ≥ 25 %: Xn, N; R21/22-51/53<br>5 % ≤ C < 25 %: Xn; R21/22-52/53<br>2,5 % ≤ C < 5 %: R52/53  |                               |
| 015-020-00-5 | mevinphos (ISO)<br>2-methoxycarbonyl-1-methylvinyl dimethyl phosphate      |                             | 232-095-1 | 7786-34-7 | T+; R27/28<br>N; R50-53     | T+; N<br>R: 27/28-50/53<br>S: (1/2-)23-28-36/37-45-60-61 | C ≥ 7 %: T+, N; R27/28-50-53<br>1 % ≤ C < 7 %: T, N; R24/25-50-53<br>0,1 % ≤ C < 1 %: Xn, N; R21/22-50-53<br>0,0025 % ≤ C < 0,1 %: N; R50-53<br>0,00025 % ≤ C < 0,0025 %: N; R51-53<br>0,000025 % ≤ C < 0,00025 %: R52-53 |                               |
| 015-021-00-0 | trichlorfon (ISO)<br>dimethyl 2,2,2-trichloro-1-hydroxyethylphosphonate    |                             | 200-149-3 | 52-68-6   | Xn; R22<br>R43<br>N; R50-53 | Xn; N<br>R: 22-43-50/53<br>S: (2-)24-37-60-61            | C ≥ 25 %: Xn, N; R22-43-50-53<br>1 % ≤ C < 25 %: Xi, N; R43-50-53<br>0,025 % ≤ C < 1 %: N; R50-53<br>0,0025 % ≤ C < 0,025 %: N; R51-53<br>0,00025 % ≤ C < 0,0025 %: R52-53  |                               |
| 015-027-00-3 | sulfotep (ISO)<br>O,O,O,O-tetraethyl dithiopyrophosphate                   |                             | 222-995-2 | 3689-24-5 | T+; R27/28<br>N; R50-53     | T+; N<br>R: 27/28-50/53<br>S: (1/2-)23-28-36/37-45-60-61 | C ≥ 7 %: T+, N; R27/28-50-53<br>1 % ≤ C < 7 %: T, N; R24/25-50-53<br>0,1 % ≤ C < 1 %: Xn, N; R21/22-50-53<br>0,025 % ≤ C < 0,1 %: N; R50-53<br>0,0025 % ≤ C < 0,025 %: N; R51-53<br>0,00025 % ≤ C < 0,0025 %: R52-53      |                               |
| 015-032-00-0 | prothoate (ISO)<br>O,O-diethyl isopropylcarbamoylmethyl phosphorodithioate |                             | 218-893-2 | 2275-18-5 | T+; R27/28<br>R52-53        | T+<br>R: 27/28-52/53<br>S: (1/2-)28-36/37-45-61          |   |                               |
| 015-033-00-6 | phorate (ISO)<br>O,O-diethyl ethylthiomethyl phosphorodithioate            |                             | 206-052-2 | 298-02-2  | T+; R27/28<br>N; R50-53     | T+; N<br>R: 27/28-50/53<br>S: (1/2-)28-36/37-45-60-61    | C ≥ 7 %: T+, N; R27/28-50-53<br>1 % ≤ C < 7 %: T, N; R24/25-50-53<br>0,1 % ≤ C < 1 %: Xn, N; R21/22-50-53<br>0,025 % ≤ C < 0,1 %: N; R50-53<br>0,0025 % ≤ C < 0,025 %: N; R51-53<br>0,00025 % ≤ C < 0,0025 %: R52-53      |                               |

| Index No     | chemical name   | Notes related to substances | EC No     | CAS No   | Classification   | Labelling   | Concentration Limits   | Notes related to preparations |
|--------------|---|-----------------------------|-----------|----------|--|---|--|-------------------------------|
| 015-034-00-1 | parathion (ISO)<br>O,O-diethyl O-4-nitrophenyl phosphorothioate   |                             | 200-271-7 | 56-38-2  | T+; R26/28<br>T; 24-48/25<br>N; R50-53                       | T+; N<br>R: 24-26/28-48/25-50/53<br>S: (1/2-)28-36/37-45-60-61      | C ≥ 25 %: T+, N; R24-26/28-48/25-50-53<br>10 % ≤ C < 25 %: T+, N; R21-26/28-48/25-50-53<br>7 % ≤ C < 10 %: T+, N; R21-26/28-48/22-50-53<br>3 % ≤ C < 7 %: T, N; R21-23/25-48/22-50-53<br>1 % ≤ C < 3 %: T, N; R23/25-48/22-50-53<br>0,25 % ≤ C < 1 %: Xn, N; R20/22-50-53<br>0,1 % ≤ C < 0,25 %: Xn, N; R20/22-51-53<br>0,025 % ≤ C < 0,1 %: N; R51-53<br>0,0025 % ≤ C < 0,025 %: R52-53 |                               |
| 015-035-00-7 | parathion - methyl (ISO)<br>O,O-dimethyl O-4-nitrophenyl phosphorothioate                               |                             | 206-050-1 | 298-00-0 | R5<br>R10<br>T+; R26/28<br>T; R24<br>Xn; R48/22<br>N; R50-53 | T+; N<br>R: 5-10-24-26/28-48/22-50/53<br>S: (1/2-)28-36/37-45-60-61 | C ≥ 25 %: T+, N; R24-26/28-48/22-50-53<br>10 % ≤ C < 25 %: T+, N; R21-26/28-48/22-50-53<br>7 % ≤ C < 10 %: T+, N; R21-26/28-50-53<br>3 % ≤ C < 7 %: T, N; R21-23/25-50-53<br>1 % ≤ C < 3 %: T, N; R23/25-50-53<br>0,25 % ≤ C < 1 %: Xn, N; R20/22-50-53<br>0,1 % ≤ C < 0,25 %: Xn, N; R20/22-51-53<br>0,025 % ≤ C < 0,1 %: N; R51-53<br>0,0025 % ≤ C < 0,025 %: R52-53                   |                               |
| 015-041-00-X | malathion (ISO)<br>1,2-bis (ethoxycarbonyl) ethyl O,O-dimethyl phosphorodithioate                       |                             | 204-497-7 | 121-75-5 | Xn; R22<br>N; R50-53   | Xn; N<br>R: 22-50/53<br>S: (2-)24-60-61                             | C ≥ 25 %: Xn, N; R22-50-53<br>0,25 % ≤ C < 25 %: N; R50-53<br>0,025 % ≤ C < 0,25 %: N; R51-53<br>0,0025 % ≤ C < 0,025 %: R52-53  |                               |
| 015-042-00-5 | chlorthion (common name not adopted by ISO)<br>O-(3-chloro-4-nitrophenyl) O,O-dimethyl phosphorothioate |                             | 207-902-5 | 500-28-7 | Xn; R20/21/22<br>N; R50-53                                   | Xn; N<br>R: 20/21/22-50/53<br>S: (2-)13-60-61                       | C ≥ 25 %: Xn, N; R20/21/22-50-53<br>0,25 % ≤ C < 25 %: N; R50-53<br>0,025 % ≤ C < 0,25 %: N; R51-53<br>0,0025 % ≤ C < 0,025 %: R52-53  |                               |
| 015-047-00-2 | ethion (ISO)<br>O,O,O',O'-tetraethyl S,S'-methylenedi (phosphorodithioate) diethion                     |                             | 209-242-3 | 563-12-2 | T; R25<br>Xn; R21<br>N; R50-53                               | T; N<br>R: 21-25-50/53<br>S: (1/2-)25-36/37-45-60-61                | C ≥ 25 %: T, N; R21-25-50-53<br>3 % ≤ C < 25 %: Xn, N; R22-50-53<br>0,0025 % ≤ C < 3 %: N; R50-53<br>0,00025 % ≤ C < 0,0025 %: N; R51-53<br>0,000025 % ≤ C < 0,00025 %: R52-53   |                               |

| Index No     | chemical name   | Notes related to substances | EC No     | CAS No     | Classification                     | Labelling  | Concentration Limits   | Notes related to preparations |
|--------------|---|-----------------------------|-----------|------------|------------------------------------|--|--|-------------------------------|
| 015-052-00-X | fenchlorphos (ISO)<br>O,O-dimethyl O-2,4,5-trichlorophenyl phosphorothioate       |                             | 206-082-6 | 299-84-3   | Xn; R21/22<br>N; R50-53            | Xn; N<br>R: 21/22-50/53<br>S: (2-)25-36/37-60-61         |  |                               |
| 015-055-00-6 | naled (ISO)<br>1,2-dibromo-2,2-dichloroethyl dimethyl phosphate                   |                             | 206-098-3 | 300-76-5   | Xn; R21/22<br>Xi; R36/38<br>N; R50 | Xn; N<br>R: 21/22-36/38-50<br>S: (2-)36/37-61            | C ≥ 25 %: Xn, N; R21/22-36/38-50<br>20 % ≤ C < 25 %: Xi, N; R36/38-50<br>0,025 % ≤ C < 20 %: N; R50  |                               |
| 015-063-00-X | dioxathion (ISO)<br>1,4-dioxan-2,3-diyl-O,O',O'-tetraethyl di(phosphorodithioate) |                             | 201-107-7 | 78-34-2    | T+; R26/28<br>T; R24<br>N; R50-53  | T+; N<br>R: 24-26/28-50/53<br>S: (1/2-)28-36/37-45-60-61 | C ≥ 25 %: T+, N; R24-26/28-50-53<br>7 % ≤ C < 25 %: T+, N; R21-26/28-50-53<br>3 % ≤ C < 7 %: T, N; R21-23/25-50-53<br>1 % ≤ C < 3 %: T, N; R23/25-50-53<br>0,1 % ≤ C < 1 %: Xn, N; R20/22-50-53<br>0,025 % ≤ C < 0,1 %: N; R50-53<br>0,0025 % ≤ C < 0,025 %: N; R51-53<br>0,00025 % ≤ C < 0,0025 %: R52-53 |                               |
| 015-065-00-0 | S-[2-(ethylsulphinyl)ethyl] O,O-dimethyl phosphorodithioate                       |                             | —         | 2703-37-9  | T+; R26/27/28<br>N; R51-53         | T+; N<br>R: 26/27/28-51/53<br>S: (1/2-)13-28-45-61       |  |                               |
| 015-076-00-0 | potasan<br>O,O-diethyl O-(4-methylcoumarin-7-yl) phosphorothioate                 |                             | —         | 299-45-6   | T+; R26/27/28<br>N; R50-53         | T+; N<br>R: 26/27/28-50/53<br>S: (1/2-)13-28-45-60-61    | C ≥ 7 %: T+, N; R26/27/28-50-53<br>1 % ≤ C < 7 %: T, N; R23/24/25-50-53<br>0,1 % ≤ C < 1 %: Xn, N; R20/21/22-50-53<br>0,025 % ≤ C < 0,1 %: N; R50-53<br>0,0025 % ≤ C < 0,025 %: N; R51-53<br>0,00025 % ≤ C < 0,0025 %: R52-53  |                               |
| 015-078-00-1 | demeton-S-methylsulphon<br>S-2-ethylsulphonylethyl dimethyl phosphorothioate      |                             | 241-109-5 | 17040-19-6 | T; R25<br>Xn; R21<br>N; R51-53     | T; N<br>R: 21-25-51/53<br>S: (1/2-)22-28-36/37-45-61     |  |                               |
| 015-083-00-9 | bensulide (ISO)<br>O,O-diisopropyl 2-phenylsulphonylaminoethyl phosphorodithioate |                             | 212-010-4 | 741-58-2   | Xn; R22<br>N; R50-53               | Xn; N<br>R: 22-50/53<br>S: (2-)24-36-60-61               |  |                               |



| Index No     | chemical name  | Notes related to substances | EC No     | CAS No     | Classification                           | Labelling   | Concentration Limits   | Notes related to preparations |
|--------------|--|-----------------------------|-----------|------------|--|---|--|-------------------------------|
| 015-084-00-4 | chlorpyrifos (ISO)<br>O,O-diethyl O-3,5,6-trichloro-2-pyridyl phosphorothioate |                             | 220-864-4 | 2921-88-2  | T; R25<br>N; R50-53                      | T; N<br>R: 25-50/53<br>S: (1/2-)45-60-61                          | C ≥ 25 %: T, N; R25-50-53<br>3 % ≤ C < 25 %: Xn, N; R22-50-53<br>0,0025 % ≤ C < 3 %: N; R50-53<br>0,00025 % ≤ C < 0,0025 %: N; R51-53<br>0,000025 % ≤ C < 0,00025 %: R52-53  |                               |
| 015-095-00-4 | methamidophos (ISO)<br>O,S-dimethyl phosphoramidothioate                       |                             | 233-606-0 | 10265-92-6 | T+; R26/28<br>T; R24<br>N; R50           | T+; N<br>R: 24-26/28-50<br>S: (1/2-)28-36/37-45-61                |  |                               |
| 015-096-00-X | oxydisulfoton; O,O-diethyl S-[2-(ethylsulphinyl)ethyl] phosphorodithioate      |                             | 219-679-1 | 2497-07-6  | T+; R28<br>T; R24<br>N; R50-53           | T+; N<br>R: 24-28-50/53<br>S: (1/2-)28-36/37-45-60-61             | C ≥ 25 %: T+, N; R24-28-50-53<br>7 % ≤ C < 25 %: T+, N; R21-28-50-53<br>3 % ≤ C < 7 %: T, N; R21-25-50-53<br>1 % ≤ C < 3 %: T, N; R25-50-53<br>0,25 % ≤ C < 1 %: Xn, N; R22-50-53<br>0,1 % ≤ C < 0,25 %: Xn, N; R22-51-53<br>0,025 % ≤ C < 0,1 %: R52-53 |                               |
| 015-097-00-5 | phenthoate (ISO)<br>ethyl 2-(dimethoxyphosphinothioylthio)-2-phenylacetate     |                             | 219-997-0 | 2597-03-7  | Xn; R21/22<br>N; R50-53                  | Xn; N<br>R: 21/22-50/53<br>S: (2-)22-36/37-60-61                  | C ≥ 25 %: Xn, N; R21/22-50-53<br>0,25 % ≤ C < 25 %: N; R50-53<br>0,025 % ≤ C < 0,25 %: N; R51-53<br>0,0025 % ≤ C < 0,025 %: R52-53   |                               |
| 015-100-00-X | phoxim (ISO)<br>α-(diethoxyphosphinothioylimino) phenylacetone nitrile         |                             | 238-887-3 | 14816-18-3 | Xn; R22<br>N; R50-53                     | Xn; N<br>R: 22-50/53<br>S: (2-)36-60-61                           | C ≥ 25 %: Xn, N; R22-50-53<br>0,025 % ≤ C < 25 %: N; R50-53<br>0,0025 % ≤ C < 0,025 %: N; R51-53<br>0,00025 % ≤ C < 0,0025 %: R52-53   |                               |
| 015-101-00-5 | phosmet (ISO)<br>O,O-dimethyl phthalimido-methyl S-phosphorodithioate          |                             | 211-987-4 | 732-11-6   | Xn; R21/22<br>N; R50-53                  | Xn; N<br>R: 21/22-50/53<br>S: (2-)22-36/37-60-61                  | C ≥ 25 %: Xn, N; R21/22-50-53<br>0,25 % ≤ C < 25 %: N; R50-53<br>0,025 % ≤ C < 0,25 %: N; R51-53<br>0,0025 % ≤ C < 0,025 %: R52-53   |                               |
| 015-105-00-7 | triphenyl phosphite  |                             | 202-908-4 | 101-02-0   | Xi; R36/38<br>N; R50-53                  | Xi; N<br>R: 36/38-50/53<br>S: (2-)28-60-61                        | C ≥ 25 %: Xi, N; R36/38-50/53<br>5 % ≤ C < 25 %: Xi, N; R36/38-51/53<br>2,5 % ≤ C < 5 %: N; R51/53<br>0,25 % ≤ C < 2,5 %: R52/53   |                               |
| 015-107-00-8 | ethoprophos (ISO)<br>ethyl-S,S-dipropyl phosphorodithioate                     |                             | 236-152-1 | 13194-48-4 | T+; R26/27<br>T; R25<br>R43<br>N; R50-53 | T+; N<br>R: 25-26/27-43-50/53<br>S: (1/2-)27/28-36/37/39-45-60-61 |  |                               |
| 015-108-00-3 | bromophos (ISO)<br>O-4-bromo-2,5-dichlorophenyl O,O-dimethyl phosphorothioate  |                             | 218-277-3 | 2104-96-3  | Xn; R22<br>N; R50-53                     | Xn; N<br>R: 22-50/53<br>S: (2-)36-60-61                           | C ≥ 25 %: Xn, N; R22-50-53<br>0,25 % ≤ C < 25 %: N; R50-53<br>0,025 % ≤ C < 0,25 %: N; R51-53<br>0,0025 % ≤ C < 0,025 %: R52-53  |                               |

| Index No     | chemical name   | Notes related to substances | EC No     | CAS No     | Classification                                  | Labelling  | Concentration Limits   | Notes related to preparations |
|--------------|---|-----------------------------|-----------|------------|---|--|--|-------------------------------|
| 015-109-00-9 | crotoxyphos (ISO)<br>1-phenylethyl 3-(dimethoxyphosphinyloxy) isocrotonate        |                             | 231-720-5 | 7700-17-6  | T; R24/25<br>N; R50-53                          | T; N<br>R: 24/25-50/53<br>S: (1/2-)28-36/37-45-60-61     | C ≥ 25 %: T, N; R24/25-50-53<br>3 % ≤ C < 25 %: Xn, N; R21/22-50-53<br>2,5 % ≤ C < 3 %: N; R50-53<br>0,25 % ≤ C < 2,5 %: N; R51-53<br>0,025 % ≤ C < 0,25 %: R52-53   |                               |
| 015-110-00-4 | cyanofenphos (ISO)<br>O-4-cyanophenyl O-ethyl phenylphosphonothioate              |                             | —         | 13067-93-1 | T; R25-39/25<br>Xn; R21<br>Xi; R36<br>N; R51-53 | T; N<br>R: 21-25-36-39/25-51/53<br>S: (1/2-)36/37-45-61  |  |                               |
| 015-114-00-6 | chlormephos (ISO)<br>S-chloromethyl O,O-diethyl phosphorodithioate                |                             | 246-538-1 | 24934-91-6 | T+; R27/28<br>N; R50-53                         | T+; N<br>R: 27/28-50/53<br>S: (1/2-)28-36/37-45-60-61    |  |                               |
| 015-115-00-1 | chlorthiophos (ISO)   |                             | 244-663-6 | 21923-23-9 | T+; R28<br>T; R24<br>N; R50-53                  | T+; N<br>R: 24-28-50/53<br>S: (1/2-)28-36/37-45-60-61    |  |                               |
| 015-122-00-X | O-6-ethoxy-2-ethylpyrimidin-4-yl O,O-dimethylphosphorothioate etrimfos            |                             | 253-855-9 | 38260-54-7 | Xn; R22<br>N; R50-53                            | Xn; N<br>R: 22-50/53<br>S: (2-)60-61                     | C ≥ 25 %: Xn, N; R22-50-53<br>2,5 % ≤ C < 25 %: N; R50-53<br>0,25 % ≤ C < 2,5 %: N; R51-53<br>0,025 % ≤ C < 0,25 %: R52-53   |                               |
| 015-123-00-5 | fenamiphos (ISO)<br>ethyl-4-methylthio- <i>m</i> -tolyl isopropyl phosphoramidate |                             | 244-848-1 | 22224-92-6 | T+; R28<br>T; R24<br>N; R50-53                  | T+; N<br>R: 24-28-50/53<br>S: (1/2-)23-28-36/37-45-60-61 | C ≥ 25 %: T+, N; R24-28-50-53<br>7 % ≤ C < 25 %: T+, N; R21-28-50-53<br>3 % ≤ C < 7 %: T, N; R21-25-50-53<br>1 % ≤ C < 3 %: T, N; R25-50-53<br>0,25 % ≤ C < 1 %: Xn, N; R22-50-53<br>0,1 % ≤ C < 0,25 %: Xn, N; R22-51-53<br>0,025 % ≤ C < 0,25 %: N; R51-53<br>0,0025 % ≤ C < 0,025 %: R52-53 |                               |
| 015-126-00-1 | heptenophos (ISO)<br>7-chlorobicyclo(3.2.0)hepta-2,6-dien-6-yl dimethyl phosphate |                             | 245-737-0 | 23560-59-0 | T; R25<br>N; R50-53                             | T; N<br>R: 25-50/53<br>S: (1/2-)23-28-37-45-60-61        | C ≥ 25 %: T, N; R25-50-53<br>3 % ≤ C < 25 %: Xn, N; R22-50-53<br>0,25 % ≤ C < 3 %: N; R50-53<br>0,025 % ≤ C < 0,25 %: N; R51-53<br>0,0025 % ≤ C < 0,025 %: R52-53  |                               |

| Index No     | chemical name  | Notes related to substances | EC No     | CAS No     | Classification                 | Labelling   | Concentration Limits  | Notes related to preparations |
|--------------|--|-----------------------------|-----------|------------|--------------------------------|---|---|-------------------------------|
| 015-127-00-7 | iprobenfos<br>S-benzyl diisopropyl phosphorothioate  |                             | 247-449-0 | 26087-47-8 | Xn; R22<br>N; R51-53           | Xn; N<br>R: 22-51/53<br>S: (2-)61                     |   |                               |
| 015-128-00-2 | IPSP<br>S-ethylsulphinylmethyl O,O-diisopropylphosphorodithioate                                   |                             | —         | 5827-05-4  | T+; R27<br>T; R25<br>N; R50-53 | T+; N<br>R: 25-27-50/53<br>S: (1/2-)28-36/37-45-60-61 | C ≥ 25 %: T+, N; R25-27-50-53<br>7 % ≤ C < 25 %: T+, N; R22-27-50-53<br>3 % ≤ C < 7 %: T, N; R22-24-50-53<br>1 % ≤ C < 3 %: T, N; R24-50-53<br>0,25 % ≤ C < 1 %: Xn, N; R21-50-53<br>0,1 % ≤ C < 0,25 %: Xn, N; R21-51-53<br>0,025 % ≤ C < 0,1 %: N; R51-53<br>0,0025 % ≤ C < 0,025 %: R52-53 |                               |
| 015-129-00-8 | isofenphos (ISO)<br>O-ethyl O-2-isopropoxycarbonylphenyl-isopropylphosphoramidothioate             |                             | 246-814-1 | 25311-71-1 | T; R24/25<br>N; R50-53         | T; N<br>R: 24/25-50/53<br>S: (1/2-)36/37-45-60-61     | C ≥ 25 %: T, N; R24/25-50-53<br>3 % ≤ C < 25 %: Xn, N; R21/22-50-53<br>0,25 % ≤ C < 3 %: N; R50-53<br>0,025 % ≤ C < 0,25 %: N; R51-53<br>0,0025 % ≤ C < 0,025 %: R52-53   |                               |
| 015-131-00-9 | isoxathion (ISO)<br>O,O-diethyl O-5-phenylisoxazol-3-ylphosphorothioate                            |                             | 242-624-8 | 18854-01-8 | T; R24/25<br>N; R50-53         | T; N<br>R: 24/25-50/53<br>S: (1/2-)28-36/37-45-60-61  |   |                               |
| 015-132-00-4 | S-(chlorophenylthiomethyl) O,O-dimethylphosphorodithioate methylcarbophenothione                   |                             | —         | 953-17-3   | T; R24/25<br>N; R50-53         | T; N<br>R: 24/25-50/53<br>S: (1/2-)28-36/37-45-60-61  | C ≥ 25 %: T, N; R24/25-50-53<br>3 % ≤ C < 25 %: Xn, N; R21/22-50-53<br>0,025 % ≤ C < 3 %: N; R50-53<br>0,0025 % ≤ C < 0,025 %: N; R51-53<br>0,00025 % ≤ C < 0,0025 %: R52-53  |                               |
| 015-133-00-X | piperophos (ISO)<br>S-2-methylpiperidinocarbonylmethyl-O,O-dipropyl phosphorodithioate             |                             | —         | 24151-93-7 | Xn; R22<br>N; R50-53           | Xn; N<br>R: 22-50/53<br>S: (2-)60-61                  | C ≥ 25 %: Xn, N; R22-50-53<br>2,5 % ≤ C < 25 %: N; R50-53<br>0,25 % ≤ C < 2,5 %: N; R51-53<br>0,025 % ≤ C < 0,25 %: R52-53  |                               |
| 015-134-00-5 | pirimiphos-methyl (ISO)<br>O-(2-diethylamino-6-methylpyrimidin-4-yl) O,O-dimethyl phosphorothioate |                             | 249-528-5 | 29232-93-7 | Xn; R22<br>N; R50-53           | Xn; N<br>R: 22-50/53<br>S: (2-)60-61                  |   |                               |
| 015-135-00-0 | O-(4-bromo-2-chlorophenyl) O-ethyl S-propyl phosphorothioate profenofos (ISO)                      |                             | 255-255-2 | 41198-08-7 | Xn; R20/21/22<br>N; R50-53     | Xn; N<br>R: 20/21/22-50/53<br>S: (2-)36/37-60-61      | C ≥ 25 %: Xn, N; R20/21/22-50-53<br>0,025 % ≤ C < 25 %: N; R50-53<br>0,0025 % ≤ C < 0,025 %: N; R51-53<br>0,00025 % ≤ C < 0,0025 %: R52-53  |                               |

| Index No     | chemical name  | Notes related to substances | EC No     | CAS No      | Classification   | Labelling   | Concentration Limits   | Notes related to preparations |
|--------------|--|-----------------------------|-----------|-------------|--|---|--|-------------------------------|
| 015-136-00-6 | <i>trans</i> -isopropyl-3-[[[(ethylamino)methoxyfosfinothiyl]oxy]crotonate; isopropyl 3-[[[(ethylamino)methoxyphosphinothiyl]oxy]isocrotonate propetamphos (ISO) |                             | 250-517-2 | 31218-83-4  | T; R25<br>N; R50-53  | T; N<br>R: 25-50/53<br>S: (1/2-)37-45-60-61                         | C ≥ 25 %: T, N; R25-50-53<br>3 % ≤ C < 25 %: Xn, N; R22-50-53<br>0,25 % ≤ C < 3 %: N; R50-53<br>0,025 % ≤ C < 0,25 %: N; R51-53<br>0,0025 % ≤ C < 0,025 %: R52-53  |                               |
| 015-138-00-7 | quinalphos (ISO)<br>O,O-diethyl-O-quinoxalin-2-yl phosphorothioate   |                             | 237-031-6 | 13593-03-8  | T; R25<br>Xn; R21<br>N; R50-53                                   | T; N<br>R: 21-25-50/53<br>S: (1/2-)22-36/37-45-60-61                | C ≥ 25 %: T, N; R21-25-50-53<br>3 % ≤ C < 25 %: Xn, N; R22-50-53<br>0,025 % ≤ C < 3 %: N; R50-53<br>0,0025 % ≤ C < 0,025 %: N; R51-53<br>0,00025 % ≤ C < 0,0025 %: R52-53  |                               |
| 015-139-00-2 | <i>S-tert</i> -butylthiomethyl O,O-diethylphosphorodithioate terbufos (ISO)  |                             | 235-963-8 | 13071-79-9  | T+; R27/28<br>N; R50-53  | T+; N<br>R: 27/28-50/53<br>S: (1/2-)36/37-45-60-61                  | C ≥ 7 %: T+, N; R27/28-50-53<br>1 % ≤ C < 7 %: T, N; R24/25-50-53<br>0,1 % ≤ C < 1 %: Xn, N; R21/22-50-53<br>0,025 % ≤ C < 0,1 %: N; R50-53<br>0,0025 % ≤ C < 0,025 %: N; R51-53<br>0,00025 % ≤ C < 0,0025 %: R52-53 |                               |
| 015-154-00-4 | 2-chloroethylphosphonic acid ethephon  |                             | 240-718-3 | 16672-87-0  | Xn; R20/21<br>C; R34<br>R52-53                                   | C<br>R: 20/21-34-52/53<br>S: (1/2-)26-28-36/37/39-45-61             | C ≥ 25 %: C; R20/21-34-52/53<br>10 % ≤ C < 25 %: C; R34<br>5 % ≤ C < 10 %: Xi; R36/37/38   |                               |
| 015-179-00-0 | UVCB condensation product of: tetrakis-hydroxymethylphosphonium chloride, urea and distilled hydrogenated C 16-18 tallow alkylamine                              |                             | 422-720-8 | 166242-53-1 | Carc. Cat. 3; R40<br>Xn; R22-48/22<br>C; R34<br>R43<br>N; R50-53 | C; N<br>R: 22-34-40-43-48/22-50/53<br>S: (1/2-)26-36/37/39-45-60-61 |  |                               |
| 016-001-00-4 | hydrogen sulphide  |                             | 231-977-3 | 7783-06-4   | F+; R12<br>T+; R26<br>N; R50                                     | F+; T+; N<br>R: 12-26-50<br>S: (1/2-)9-16-36-38-45-61               |  |                               |
| 016-008-00-2 | ammonium polysulphides   |                             | 232-989-1 | 9080-17-5   | R31<br>C; R34<br>N; R50  | C; N<br>R: 31-34-50<br>S: (1/2-)26-45-61                            | C ≥ 25 %: C, N; R31-34-50<br>5 % ≤ C < 25 %: C; R31-34<br>1 % ≤ C < 5 %: Xi; R31-36/38   |                               |
| 016-012-00-4 | disulphur dichloride<br>sulfur monochloride  |                             | 233-036-2 | 10025-67-9  | R14<br>T; R25<br>Xn; R20<br>R29<br>C; R35<br>N; R50              | T; C; N<br>R: 14-20-25-29-35-50<br>S: (1/2-)26-36/37/39-45-61       | C ≥ 25 %: T, C, N; R20-25-35-50<br>10 % ≤ C < 25 %: C; R22-35<br>5 % ≤ C < 10 %: C; R22-34<br>3 % ≤ C < 5 %: Xn; R22-36/37/38<br>1 % ≤ C < 3 %: Xi; R36/37/38  |                               |

| Index No     | chemical name   | Notes related to substances | EC No     | CAS No     | Classification   | Labelling   | Concentration Limits   | Notes related to preparations |
|--------------|---|-----------------------------|-----------|------------|--|---|--|-------------------------------|
| 016-013-00-X | sulphur dichloride  |                             | 234-129-0 | 10545-99-0 | R14<br>C; R34<br>Xi; R37<br>N; R50   | C; N<br>R: 14-34-37-50<br>S: (1/2-)26-45-61         | C ≥ 25 %: C, N ; R34-50<br>10 % ≤ C < 25 %: C; R34<br>5 % ≤ C < 10 %: Xi; R36/37/38  |                               |
| 016-014-00-5 | sulphur tetrachloride   |                             | —         | 13451-08-6 | R14<br>C; R34<br>N; R50  | C; N<br>R: 14-34-50<br>S: (1/2-)26-45-61            | C ≥ 25 %: C, N; R34-50<br>10 % ≤ C < 25 %: C; R34<br>5 % ≤ C < 10 %: Xi; R36/37/38   |                               |
| 016-021-00-3 | methanethiol<br>methyl mercaptan  |                             | 200-822-1 | 74-93-1    | F+; R12<br>T; R23<br>N; R50-53   | F+; T; N<br>R: 12-23-50/53<br>S: (2-)16-25-60-61    |  |                               |
| 016-023-00-4 | dimethyl sulphate   | E                           | 201-058-1 | 77-78-1    | Carc. Cat. 2; R45<br>Muta. Cat. 3; R68<br>T+; R26<br>T; R25<br>C; R34<br>R43 | T+<br>R: 45-25-26-34-43-68<br>S: 53-45              | C ≥ 25 %: T+; R45-R25-R26-R34-R43-<br>R68<br>10 % ≤ C < 25 %: T+; R45-R22-R26-R34-<br>R43-R68<br>7 % ≤ C < 10 %: T+; R45-R22-R26-R36/<br>37/38-R43-R68<br>5 % ≤ C < 7 %: T; R45-R22-R23-R36/37/<br>38-R43-R68<br>3 % ≤ C < 5 %: T; R45-R22-R23-R43-<br>R68<br>1 % ≤ C < 3 %: T; R45-R23-R43-R68<br>0,1 % ≤ C < 1 %: T; R45-R20-R68<br>0,01 % ≤ C < 0,1 %: T; R45-R68 |                               |
| 016-059-00-0 | N,N,N',N'-tetramethyldithiobi-<br>s(ethylene)diamine dihydrochlor-<br>ide |                             | 405-300-9 | 17339-60-5 | Xn; R22<br>Xi; R36<br>R43<br>N; R50-53                                       | Xn; N<br>R: 22-36-43-50/53<br>S: (2-)26-36/37-60-61 |  |                               |
| 017-003-00-8 | barium chlorate   |                             | 236-760-7 | 13477-00-4 | O; R9<br>Xn; R20/22<br>N; R51-53   | O; Xn; N<br>R: 9-20/22-51/53<br>S: (2-)13-27-61     |  |                               |
| 017-004-00-3 | potassium chlorate  |                             | 223-289-7 | 3811-04-9  | O; R9<br>Xn; R20/22<br>N; R51-53   | O; Xn; N<br>R: 9-20/22-51/53<br>S: (2-)13-16-27-61  |  |                               |
| 017-005-00-9 | sodium chlorate   |                             | 231-887-4 | 7775-09-9  | O; R9<br>Xn; R22<br>N; R51-53  | O; Xn; N<br>R: 9-22-51/53<br>S: (2-)13-17-46-61     |  |                               |
| 017-011-00-1 | sodium hypochlorite, solution<br>... % Cl active                          | B                           | 231-668-3 | 7681-52-9  | C; R34<br>R31<br>N; R50  | C; N<br>R: 31-34-50<br>S: (1/2-)28-45-50-61         | C ≥ 25 %: C, N; R31-34-50<br>10 % ≤ C < 25 %: C; R31-34<br>5 % ≤ C < 10 %: Xi; R31-36/38   |                               |

| Index No     | chemical name          | Notes related to substances | EC No     | CAS No    | Classification  | Labelling  | Concentration Limits   | Notes related to preparations |
|--------------|------------------------|-----------------------------|-----------|-----------|---|--|--|-------------------------------|
| 017-012-00-7 | calcium hypochlorite   |                             | 231-908-7 | 7778-54-3 | O; R8<br>Xn; R22<br>R31<br>C; R34<br>N; R50   | O; C; N<br>R: 8-22-31-34-50<br>S: (1/2-)26-36/37/39-45-61                    | C ≥ 25 %: C, N; R22-34-50<br>10 % ≤ C < 25 %: C; R34<br>3 % ≤ C < 10 %: Xi; R37/38-41<br>0,5 % ≤ C < 3 %: Xi; R36  |                               |
| 024-001-00-0 | chromium (VI) trioxide | E                           | 215-607-8 | 1333-82-0 | O; R9<br>Carc. Cat. 1; R45<br>Muta. Cat. 2; R46<br>Repr. Cat. 3; R62<br>T+; R26<br>T; R24/25-48/23<br>C; R35<br>R42/43<br>N; R50-53           | O; T+; N<br>R: 45-46-9-24/25-26-35-42/43-48/23-62-50/53<br>S: 53-45-60-61    | C ≥ 25 %: T+, N; R24/25-26-35-42/43-45-46-48/23-50/53-62<br>10 % ≤ C < 25 %: T+, N; R21/22-26-35-42/43-45-46-48/23-51/53-62<br>7 % ≤ C < 10 %: T+, N; R21/22-26-34-42/43-45-46-48/20-51/53-62<br>5 % ≤ C < 7 %: T, N; R21/22-23-34-42/43-45-46-48/20-51/53-62<br>3 % ≤ C < 5 %: T, N; R21/22-23-36/37/38-42/43-45-46-48/20-51/53<br>2,5 % ≤ C < 3 %: T, N; R23-36/37/38-42/43-45-46-48/20-51/53<br>1 % ≤ C < 2,5 %: T; R23-36/37/38-42/43-45-46-48/20-52/53<br>0,25 % ≤ C < 1 %: T; R20-45-46-52/53<br>0,1 % ≤ C < 0,25 %: T; R20-45-46  |                               |
| 024-002-00-6 | potassium dichromate   | E                           | 231-906-6 | 7778-50-9 | O; R8<br>Carc. Cat. 2; R45<br>Muta. Cat. 2; R46<br>Repr. Cat. 2; R60-61<br>T+; R26<br>T; R25-48/23<br>Xn; R21<br>C; R34<br>R42/43<br>N; 50-53 | T+; N; O<br>R: 45-46-60-61-8-21-25-26-34-42/43-48/23-50/53<br>S: 53-45-60-61 | C ≥ 25 %: T+, N; R45-46-60-61-21-25-26-34-42/43-48/23-50/53<br>10 % ≤ C < 25 %: T+, N; R45-46-60-61-22-26-34-42/43-48/23-51/53<br>7 % ≤ C < 10 %: T+, N; R45-46-60-61-22-26-36/37/38-42/43-48/20-51/53<br>5 % ≤ C < 7 %: T, N; R45-46-60-61-22-23-36/37/38-42/43-48/20-51/53<br>3 % ≤ C < 5 %: T, N; R45-46-60-61-22-23-42/43-48/20-51/53<br>2,5 % ≤ C < 3 %: T, N; R45-46-60-61-23-42/43-48/20-51/53<br>1 % ≤ C < 2,5 %: T; R45-46-60-61-23-42/43-48/20-52/53<br>0,5 % ≤ C < 1 %: T; R45-46-60-61-20-42/43-52/53<br>0,25 % ≤ C < 0,5 %: T; R45-46-20-42/43-52/53<br>0,2 % ≤ C < 0,25 %: T; R45-46-20-42/43<br>0,1 % ≤ C < 0,2 %: T; R45-46-20 | 3                             |

| Index No     | chemical name               | Notes related to substances | EC No     | CAS No     | Classification  | Labelling  | Concentration Limits   | Notes related to preparations |
|--------------|-----------------------------|-----------------------------|-----------|------------|---|--|--|-------------------------------|
| 024-003-00-1 | ammonium dichromate         | E                           | 232-143-1 | 7789-09-5  | E; R2<br>O; R8<br>Carc. Cat. 2; R45<br>Muta. Cat. 2; R46<br>Repr. Cat. 2; R60-61<br>T+; R26<br>T; R25-48/23<br>Xn; R21<br>C; R34<br>R42/43<br>N; R50-53 | E; T+; N<br>R: 45-46-60-61-2-8-21-25-26-34-42/43-48/23-50/53<br>S: 53-45-60-61 | C ≥ 25 %: T+, N; R45-46-60-61-21-25-26-34-42/43-48/23-50/53<br>10 % ≤ C < 25 %: T+, N; R45-46-60-61-22-26-34-42/43-48/23-50/53<br>7 % ≤ C < 10 %: T+, N; R45-46-60-61-22-26-36/37/38-42/43-48/20-50/53<br>5 % ≤ C < 7 %: T, N; R45-46-60-61-22-23-36/37/38-42/43-48/20-51/53<br>3 % ≤ C < 5 %: T, N; R45-46-60-61-22-23-42/43-48/20-51/53<br>2,5 % ≤ C < 3 %: T, N; R45-46-60-61-23-42/43-48/20-51/53<br>1 % ≤ C < 2,5 %: T; R45-46-60-61-23-42/43-48/20-52/53<br>0,5 % ≤ C < 1 %: T; R45-46-60-61-20-42/43-52/53<br>0,25 % ≤ C < 0,5 %: T; R45-46-20-42/43-52/53<br>0,2 % ≤ C < 0,25 %: T; R45-46-20-42/43<br>0,1 % ≤ C < 0,2 %: T; R45-46-20 | 3                             |
| 024-004-00-7 | sodium dichromate anhydrate | E                           | 234-190-3 | 10588-01-9 | O; R8<br>Carc. Cat. 2; R45<br>Muta. Cat. 2; R46<br>Repr. Cat. 2; R60-61<br>T+; R26<br>T; R25-48/23<br>Xn; R21<br>C; R34<br>R42/43<br>N; 50-53           | T+; N; O<br>R: 45-46-60-61-8-21-25-26-34-42/43-48/23-50/53<br>S: 53-45-60-61   | C ≥ 25 %: T+, N; R45-46-60-61-21-25-26-34-42/43-48/23-50/53<br>10 % ≤ C < 25 %: T+, N; R45-46-60-61-22-26-34-42/43-48/23-51/53<br>7 % ≤ C < 10 %: T+, N; R45-46-60-61-22-26-36/37/38-42/43-48/20-51/53<br>5 % ≤ C < 7 %: T, N; R45-46-60-61-22-23-36/37/38-42/43-48/20-51/53<br>3 % ≤ C < 5 %: T, N; R45-46-60-61-22-23-42/43-48/20-51/53<br>2,5 % ≤ C < 3 %: T, N; R45-46-60-61-23-42/43-48/20-51/53<br>1 % ≤ C < 2,5 %: T; R45-46-60-61-23-42/43-48/20-52/53<br>0,5 % ≤ C < 1 %: T; R45-46-60-61-20-42/43-52/53<br>0,25 % ≤ C < 0,5 %: T; R45-46-20-42/43-52/53<br>0,2 % ≤ C < 0,25 %: T; R45-46-20-42/43<br>0,1 % ≤ C < 0,2 %: T; R45-46-20 | 3                             |

| Index No     | chemical name  | Notes related to substances | EC No     | CAS No    | Classification  | Labelling  | Concentration Limits   | Notes related to preparations |
|--------------|--|-----------------------------|-----------|-----------|---|--|--|-------------------------------|
| 024-004-01-4 | sodium dichromate, dihydrate   | E                           | 234-190-3 | 7789-12-0 | O; R8<br>Carc. Cat.2; R45<br>Muta. Cat. 2; R46<br>Repr. Cat. 2; R60-61<br>T+; R26<br>T; R25-48/23<br>Xn; R21<br>C; R34<br>R42/43<br>N; R50-53 | T+; N; O<br>R: 45-46-60-61-8-21-25-26-34-42/43-48/23-50/53<br>S: 53-45-60-61 | C ≥ 25 %: T+, N; R45-46-60-61-21-25-26-34-42/43-48/23-50/53<br>10 % ≤ C < 25 %: T+, N; R45-46-60-61-22-26-34-42/43-48/23-51/53<br>7 % ≤ C < 10 %: T+, N; R45-46-60-61-22-26-36/37/38-42/43-48/20-51/53<br>5 % ≤ C < 7 %: T, N; R45-46-60-61-22-23-36/37/38-42/43-48/20-51/53<br>3 % ≤ C < 5 %: T, N; R45-46-60-61-22-23-42/43-48/20-51/53<br>2,5 % ≤ C < 3 %: T, N; R45-46-60-61-23-42/43-48/20-51/53<br>1 % ≤ C < 2,5 %: T; R45-46-60-61-23-42/43-48/20-52/53<br>0,5 % ≤ C < 1 %: T; R45-46-60-61-20-42/43-52/53<br>0,25 % ≤ C < 0,5 %: T; R45-46-20-42/43-52/53<br>0,2 % ≤ C < 0,25 %: T; R45-46-20-42/43<br>0,1 % ≤ C < 0,2 %: T; R45-46-20 | 3                             |
| 024-011-00-5 | ammonium bis(1-(3,5-dinitro-2-oxidophenylazo)-3-(N-phenylcarbamoyl)-2-naphtholato)chromate(1-) |                             | 400-110-2 | —         | F; R11<br>N; R50-53   | F; N<br>R: 11-50/53<br>S: (2-)33-60-61                                       |  |                               |
| 024-018-00-3 | sodium chromate  | E                           | 231-889-5 | 7775-11-3 | Carc. Cat. 2; R45<br>Muta. Cat. 2; R46<br>Repr. Cat.2; R60-61<br>T+; R26<br>T; R25-48/23<br>Xn; R21<br>C; R34<br>R42/43<br>N; R50-53          | T+; N<br>R: 45-46-60-61-21-25-26-34-42/43-48/23-50/53<br>S: 53-45-60-61      | C ≥ 25 %: T+, N; R45-46-60-61-21-25-26-34-42/43-48/23-50/53<br>10 % ≤ C < 25 %: T+, N; R45-46-60-61-22-26-34-42/43-48/23-51/53<br>7 % ≤ C < 10 %: T+, N; R45-46-60-61-22-26-36/37/38-42/43-48/20-51/53<br>5 % ≤ C < 7 %: T, N; R45-46-60-61-22-23-36/37/38-42/43-48/20-51/53<br>3 % ≤ C < 5 %: T, N; R45-46-60-61-22-23-42/43-48/20-51/53<br>2,5 % ≤ C < 3 %: T, N; R45-46-60-61-23-42/43-48/20-51/53<br>1 % ≤ C < 2,5 %: T; R45-46-60-61-23-42/43-48/20-52/53<br>0,5 % ≤ C < 1 %: T; R45-46-60-61-20-42/43-52/53<br>0,25 % ≤ C < 0,5 %: T; R45-46-20-42/43-52/53<br>0,2 % ≤ C < 0,25 %: T; R45-46-20-42/43<br>0,1 % ≤ C < 0,2 %: T; R45-46-20 | 3                             |



| Index No     | chemical name  | Notes related to substances | EC No                          | CAS No                         | Classification                                      | Labelling   | Concentration Limits   | Notes related to preparations |
|--------------|--|-----------------------------|--------------------------------|--------------------------------|---|---|--|-------------------------------|
| 027-004-00-5 | cobalt dichloride  | E                           | 231-589-4                      | 7646-79-9                      | Carc. Cat. 2; R49<br>Xn; R22<br>R42/43<br>N; R50-53 | T; N<br>R: 49-22-42/43-50/53<br>S: (2-)22-53-45-60-61   | C ≥ 25 %: T, N; R49-22-42/43-50/53<br>2,5 % ≤ C < 25 %: T, N; R49-22-42/43-51/53<br>1 % ≤ C < 2,5 %: T; R49-42/43-52/53<br>0,25 % ≤ C < 1 %: T; R49-52/53<br>0,01 % ≤ C < 0,25 %: T; R49 | 1                             |
| 027-005-00-0 | cobalt sulphate  | E                           | 233-334-2                      | 10124-43-3                     | Carc. Cat. 2; R49<br>Xn; R22<br>R42/43<br>N; R50-53 | T; N<br>R: 49-22-42/43-50/53<br>S: (2-)22-53-45-60-61   | C ≥ 25 %: T, N; R49-22-42/43-50/53<br>2,5 % ≤ C < 25 %: T, N; R49-42/43-51/53<br>1 % ≤ C < 2,5 %: T; R49-42/43-52/53<br>0,25 % ≤ C < 1 %: T; R49-52/53<br>0,01 % ≤ C < 0,25 %: T; R49    | 1                             |
| 029-002-00-X | dicopper oxide<br>copper (I) oxide   |                             | 215-270-7                      | 1317-39-1                      | Xn; R22<br>N; 50-53                                 | Xn; N<br>R: 22-50/53<br>S: (2-)22-60-61                 |  |                               |
| 030-001-00-1 | zinc powder - zinc dust<br>(pyrophoric)  |                             | 231-175-3                      | 7440-66-6                      | F; R15-17<br>N; R50-53                              | F; N<br>R: 15-17-50/53<br>S: (2-)43-46-60-61            |  |                               |
| 030-002-00-7 | zinc powder - zinc dust<br>(stabilized)  |                             | 231-175-3                      | 7440-66-6                      | N; R50-53   | N<br>R: 50/53<br>S: 60-61                               |  |                               |
| 030-003-00-2 | zinc chloride  |                             | 231-592-0                      | 7646-85-7                      | Xn; R22<br>C; R34<br>N; R50-53                      | C; N<br>R: 22-34-50/53<br>S: (1/2-)26-36/37/39-45-60-61 | C ≥ 25 %: C, N; R22-34-50/53<br>10 % ≤ C < 25 %: C, N; R34-51/53<br>5 % ≤ C < 10 %: Xn, N; R36/37/38-51/53<br>2,5 % ≤ C < 5 %: N; R51/53<br>0,25 % ≤ C < 2,5 %: R52/53                   |                               |
| 030-006-00-9 | zinc sulphate (hydrous) (mono-,<br>hexa- and hepta hydrate)<br>[1]<br>zinc sulphate (anhydrous)<br>[2] |                             | 231-793-3 [1]<br>231-793-3 [2] | 7446-19-7 [1]<br>7733-02-0 [2] | Xn; R22<br>R41<br>N; R50-53                         | Xn; N<br>R: 22-41-50/53<br>S: (2-)22-26-39-46-60-61     |  |                               |
| 033-001-00-X | arsenic  |                             | 231-148-6                      | 7440-38-2                      | T; R23/25<br>N; R50-53                              | T; N<br>R: 23/25-50/53<br>S: (1/2-)20/21-28-45-60-61    |  |                               |

| Index No     | chemical name  | Notes related to substances | EC No     | CAS No      | Classification                                      | Labelling  | Concentration Limits  | Notes related to preparations |
|--------------|--|-----------------------------|-----------|-------------|---|--|---|-------------------------------|
| 033-002-00-5 | arsenic compounds, with the exception of those specified elsewhere in this Annex   | A                           | —         | —           | T; R23/25<br>N; R50-53                              | T; N<br>R: 23/25-50/53<br>S: (1/2-)20/21-28-45-60-61             | C ≥ 25 %: T, N; R23/25-50/53<br>2,5 % ≤ C < 25 %: T, N; R23/25-51/53<br>0,25 % ≤ C < 2,5 %: T; R23/25-52/53<br>0,2 % ≤ C < 0,25 %: T; R23/25<br>0,1 % ≤ C < 0,2 %: Xn; R20/22   | 1                             |
| 042-002-00-4 | tetrakis(dimethylditetradecylammonium) hexa-μ-oxotetra-μ3-oxodi-μ5-oxotetradecaooctamolybdate(4-)  |                             | 404-760-8 | 117342-25-3 | T; R23<br>Xi; R41<br>R53                            | T<br>R: 23-41-53<br>S: (1/2-)26-37/39-45-61                      |   |                               |
| 048-001-00-5 | cadmium compounds, with the exception of cadmium sulphoselenide (xCdS.yCdSe), mixture of cadmium sulphide with zinc sulphide (xCdS.yZnS), mixture of cadmium sulphide with mercury sulphide (xCdS.yHgS), and those specified elsewhere in this Annex | A                           | —         | —           | Xn; R20/21/22<br>N; R50-53                          | Xn; N<br>R: 20/21/22-50/53<br>S: (2-)60-61                       | C ≥ 25 %: Xn, N; R20/21/22-50/53<br>2,5 % ≤ C < 25 %: Xn, N; R20/21/22-51/53<br>0,25 % ≤ C < 2,5 %: Xn; R20/21/22-52/53<br>0,1 % ≤ C < 0,25 %: Xn; R20/21/22  | 1                             |
| 048-003-00-6 | cadmium diformate<br>cadmiumformate  |                             | 224-729-0 | 4464-23-7   | T; R23/25<br>R33<br>Xn; R68<br>N; R50-53            | T; N<br>R: 23/25-33-68-50/53<br>S: (1/2-)22-45-60-61             | C ≥ 25 %: T, N; R23/25-33-50/53-68<br>10 % ≤ C < 25 %: T, N; R23/25-33-51/53-68<br>2,5 % ≤ C < 10 %: Xn, N; R20/22-33-51/53-68<br>1 % ≤ C < 2,5 %: Xn; R20/22-33-52/53-68<br>0,1 % ≤ C < 1 %: Xn; R20/22-33-52/53<br>0,25 % ≤ C < 0,1 %: Xn; R20/22-33-52/53                        |                               |
| 048-004-00-1 | cadmium cyanide  |                             | 208-829-1 | 542-83-6    | T+; R26/27/28<br>R32<br>R33<br>Xn; R68<br>N; R50-53 | T+; N<br>R: 26/27/28-32-33-68-50/53<br>S: (1/2-)7-28-29-45-60-61 | C ≥ 25 %: T+, N; R26/27/28-32-33-50/53-68<br>7 % ≤ C < 25 %: T+, N; R26/27/28-32-33-51/53-68<br>2,5 % ≤ C < 7 %: T, N; R23/24/25-32-33-51/53-68<br>1 % ≤ C < 2,5 %: T; R23/24/25-32-33-52/53-68<br>0,25 % ≤ C < 1 %: Xn; R20/21/22-33-52/53<br>0,1 % ≤ C < 0,25 %: Xn; R20/21/22-33 |                               |

| Index No     | chemical name   | Notes related to substances | EC No     | CAS No     | Classification  | Labelling  | Concentration Limits  | Notes related to preparations |
|--------------|---|-----------------------------|-----------|------------|---|--|---|-------------------------------|
| 048-005-00-7 | cadmiumhexafluorosilicate(2-)<br>cadmium fluorosilica |                             | 241-084-0 | 17010-21-8 | T; R23/25<br>R33<br>Xn; R68<br>N; R50-53  | T; N<br>R: 23/25-33-68-50/53<br>S: (1/2-)-22-45-60-61              | C ≥ 25 %: T, N; R23/25-33-50/53-68<br>10 % ≤ C < 25 %: T, N; R23/25-33-51/<br>53-68<br>2,5 % ≤ C < 10 %: Xn, N; R20/22-33-51/<br>53-68<br>1 % ≤ C < 2,5 %: Xn; R20/22-33-52/53-<br>68<br>0,25 % ≤ C < 1 %: Xn; R20/22-33-52/53<br>0,1 % ≤ C < 0,25 %: Xn; R20/22-33   |                               |
| 048-006-00-2 | cadmium fluoride                                      | E                           | 232-222-0 | 7790-79-6  | Carc. Cat. 2; R45<br>Muta. Cat. 2; R46<br>Repr. Cat. 2; R60-61<br>T+; R26<br>T; R25-48/23/25<br>N; R50-53 | T+; N<br>R: 45-46-60-61-25-26-<br>48/23/25-50/53<br>S: 53-45-60-61 | C ≥ 25 %: T+, N; R45-46-60-61-25-26-<br>48/23/25-50/53<br>10 % ≤ C < 25 %: T+, N; R45-46-60-61-<br>25-26-48/23/25-51/53<br>7 % ≤ C < 10 %: T+, N; R45-46-60-61-<br>22-26-48/23/25-51/53<br>2,5 % ≤ C < 7 %: T, N; R45-46-60-61-22-<br>23-48/20/22-51/53<br>1 % ≤ C < 2,5 %: T; R45-46-60-61-22-<br>23-48/20/22-52/53<br>0,5 % ≤ C < 1 %: T; R45-46-60-61-20/22-<br>48/20/22-52/53<br>0,25 % ≤ C < 0,5 %: T; R45-46-20/22-48/<br>20/22-52/53<br>0,1 % ≤ C < 0,25 %: T; R45-46-20/22-48/<br>20/22<br>0,01 % ≤ C < 0,1 %: T; R45 |                               |
| 048-007-00-8 | cadmium iodide  |                             | 232-223-6 | 7790-80-9  | T; R23/25<br>R33<br>Xn; R68<br>N; R50-53  | T; N<br>R: 23/25-33-68-50/53<br>S: (1/2-)-22-45-60-61              | C ≥ 25 %: T, N; R23/25-33-50/53-68<br>10 % ≤ C < 25 %: T, N; R23/25-33-51/<br>53-68<br>2,5 % ≤ C < 10 %: Xn, N; R20/22-33-51/<br>53-68<br>1 % ≤ C < 2,5 %: Xn; R20/22-33-52/53-<br>68<br>0,25 % ≤ C < 1 %: Xn; R20/22-33-52/53<br>0,1 % ≤ C < 0,25 %: Xn; R20/22-33   |                               |

| Index No     | chemical name    | Notes related to substances | EC No     | CAS No     | Classification   | Labelling  | Concentration Limits  | Notes related to preparations |
|--------------|------------------|-----------------------------|-----------|------------|--|--|---|-------------------------------|
| 048-008-00-3 | cadmium chloride | E                           | 233-296-7 | 10108-64-2 | Carc. Cat. 2; R45<br>Muta. Cat. 2; R46<br>Repr. Cat. 2; R60-61<br>T+; R26<br>T; R25-48/23/25<br>N; R50-53        | T+; N<br>R: 45-46-60-61-25-26-48/23/25-50/53<br>S: 53-45-60-61 | C ≥ 25 %: T+, N; R45-46-60-61-25-26-48/23/25-50/53<br>10 % ≤ C < 25 %: T+, N; R45-46-60-61-25-26-48/23/25-51/53<br>7 % ≤ C < 10 %: T+, N; R45-46-60-61-22-26-48/23/25-51/53<br>2,5 % ≤ C < 7 %: T, N; R45-46-60-61-22-23-48/20/22-51/53<br>1 % ≤ C < 2,5 %: T; R45-46-60-61-22-23-48/20/22-52/53<br>0,5 % ≤ C < 1 %: T; R45-46-60-61-20/22-48/20/22-52/53<br>0,25 % ≤ C < 0,5 %: T; R45-46-20/22-48/20/22-52/53<br>0,1 % ≤ C < 0,25 %: T; R45-46-20/22-48/20/22<br>0,01 % ≤ C < 0,1 %: T; R45 |                               |
| 048-009-00-9 | cadmium sulphate | E                           | 233-331-6 | 10124-36-4 | Carc. Cat. 2; R45<br>Muta. Cat. 2; R46<br>Repr. Cat. 2; R60-61<br>T; R48/23/25<br>T+; R26<br>T; R25<br>N; R50-53 | T+; N<br>R: 45-46-60-61-25-26-48/23/25-50/53<br>S: 53-45-60-61 | C ≥ 25 %: T+, N; R45-46-60-61-25-26-48/23/25-50/53<br>10 % ≤ C < 25 %: T+, N; R45-46-60-61-25-26-48/23/25-51/53<br>7 % ≤ C < 10 %: T+, N; R45-46-60-61-22-26-48/23/25-51/53<br>2,5 % ≤ C < 7 %: T, N; R45-46-60-61-22-23-48/20/22-51/53<br>1 % ≤ C < 2,5 %: T; R45-46-60-61-22-23-48/20/22-52/53<br>0,5 % ≤ C < 1 %: T; R45-46-60-61-20/22-48/20/22-52/53<br>0,25 % ≤ C < 0,5 %: T; R45-46-20/22-48/20/22-52/53<br>0,1 % ≤ C < 0,25 %: T; R45-46-20/22-48/20/22<br>0,01 % ≤ C < 0,1 %: T; R45 |                               |
| 048-010-00-4 | cadmium sulphide | E                           | 215-147-8 | 1306-23-6  | Carc. Cat. 2; R45<br>Muta. Cat. 3; R68<br>Repr. Cat. 3; R62-63<br>T; R48/23/25<br>Xn; R22<br>R53                 | T; N<br>R: 45-22-48/23/25-62-63-68-53<br>S: 53-45-61           | C ≥ 25 %: T; R45-22-48/23/25-62-63-68-53<br>10 % ≤ C < 25 %: T; R45-22-48/23/25-62-63-68<br>5 % ≤ C < 10 %: T; R45-48/20/22-62-63-68<br>1 % ≤ C < 5 %: T; R45-48/20/22-68<br>0,1 % ≤ C < 1 %: T; R45-48/20/22   | 1                             |

| Index No     | chemical name   | Notes related to substances | EC No                          | CAS No                           | Classification  | Labelling  | Concentration Limits  | Notes related to preparations |
|--------------|---|-----------------------------|--------------------------------|----------------------------------|---|--|---|-------------------------------|
| 050-001-00-5 | tin tetrachloride<br>stannic chloride   |                             | 231-588-9                      | 7646-78-8                        | C; R34<br>R52-53                                      | C<br>R: 34-52/53<br>S: (1/2-)7/8-26-45-61                              | C ≥ 25 %: C; R34-52/53<br>10 % ≤ C < 25 %: C; R34<br>5 % ≤ C < 10 %: Xi; R36/37/38  |                               |
| 050-005-00-7 | trimethyltin compounds, with the exception of those specified elsewhere in this Annex | A                           | —                              | —                                | T+; R26/27/28<br>N; R50-53                            | T+; N<br>R: 26/27/28-50/53<br>S: (1/2-)26-27-28-45-60-61               | C ≥ 25 %: T+, N; R26/27/28-50/53<br>2,5 % ≤ C < 25 %: T+, N; R26/27/28-51/53<br>0,5 % ≤ C < 2,5 %: T+; R26/27/28-52/53<br>0,25 % ≤ C < 0,5 %: T; R23/24/25-52/53<br>0,1 % ≤ C < 0,25 %: T; R23/24/25<br>0,05 % ≤ C < 0,1 %: Xn; R20/21/22 | 1                             |
| 050-006-00-2 | triethyltin compounds, with the exception of those specified elsewhere in this Annex  | A                           | —                              | —                                | T+; R26/27/28<br>N; R50-53                            | T+; N<br>R: 26/27/28-50/53<br>S: (1/2-)26-27-28-45-60-61               | C ≥ 25 %: T+, N; R26/27/28-50/53<br>2,5 % ≤ C < 25 %: T+, N; R26/27/28-51/53<br>0,5 % ≤ C < 2,5 %: T+; R26/27/28-52/53<br>0,25 % ≤ C < 0,5 %: T; R23/24/25-52/53<br>0,1 % ≤ C < 0,25 %: T; R23/24/25<br>0,05 % ≤ C < 0,1 %: Xn; R20/21/22 | 1                             |
| 050-007-00-8 | tripropyltin compounds, with the exception of those specified elsewhere in this Annex | A                           | —                              | —                                | T; R23/24/25<br>N; R50-53                             | T; N<br>R: 23/24/25-50/53<br>S: (1/2-)26-27-28-45-60-61                | C ≥ 25 %: T, N; R23/24/25-50/53<br>2,5 % ≤ C < 25 %: T, N; R23/24/25-51/53<br>0,5 % ≤ C < 2,5 %: T; R23/24/25-52/53<br>0,25 % ≤ C < 0,5 %: Xn; R20/21/22-52/53<br>0,1 % ≤ C < 0,25 %: Xn; R20/21/22                                       | 1                             |
| 050-008-00-3 | tributyltin compounds, with the exception of those specified elsewhere in this Annex  | A                           | —                              | —                                | T; R25-48/23/25<br>Xn; R21<br>Xi; R36/38<br>N; R50-53 | T; N<br>R: 21-25-36/38-48/23/25-50/53<br>S: (1/2-)35-36/37/39-45-60-61 | C ≥ 25 %: T, N; R21-25-36/38-48/23/25-50/53<br>2,5 % ≤ C < 25 %: T, N; R21-25-36/38-48/23/25-51/53<br>1 % ≤ C < 2,5 %: T; R21-25-36/38-48/23/25-52/53<br>0,25 % ≤ C < 1 %: Xn; R22-48/20/22-52/53   | 1                             |
| 050-009-00-9 | fluorotripentylstannane [1]<br>hexapentyldistannoxane [2]                             |                             | 243-546-7 [1]<br>247-143-7 [2] | 20153-49-5 [1]<br>25637-27-8 [2] | Xn; R20/21/22<br>N; R50-53                            | Xn; N<br>R: 20/21/22-50/53<br>S: (2-)26-28-60-61                       | C ≥ 25 %: Xn, N; R20/21/22-50/53<br>2,5 % ≤ C < 25 %: Xn, N; R20/21/22-51/53<br>1 % ≤ C < 2,5 %: Xn; R20/21/22-52/53<br>0,25 % ≤ C < 1 %: R52/53  | 1                             |
| 050-010-00-4 | fluorotrihexylstannane  |                             | 243-547-2                      | 20153-50-8                       | Xn; R20/21/22<br>N; R50-53                            | Xn; N<br>R: 20/21/22-50/53<br>S: (2-)26-28-60-61                       | C ≥ 25 %: Xn, N; R20/21/22-50/53<br>2,5 % ≤ C < 25 %: Xn, N; R20/21/22-51/53<br>1 % ≤ C < 2,5 %: Xn; R20/21/22-52/53<br>0,25 % ≤ C < 1 %: R52/53  | 1                             |

| Index No     | chemical name  | Notes related to substances | EC No   | CAS No  | Classification                    | Labelling  | Concentration Limits  | Notes related to preparations |
|--------------|--|-----------------------------|---|---|-----------------------------------|--|---|-------------------------------|
| 050-011-00-X | triphenyltin compounds, with the exception of those specified elsewhere in this Annex  | A                           | —   | —   | T; R23/24/25<br>N; R50-53         | T; N<br>R: 23/24/25-50/53<br>S: (1/2-)26-27-28-45-60-61  | C ≥ 25 %: T, N; R23/24/25-50/53<br>2,5 % ≤ C < 25 %: T, N; R23/24/25-51/53<br>1 % ≤ C < 2,5 %: T; R23/24/25-52/53<br>0,25 % ≤ C < 1 %: Xn; R20/21/22-52/53  | 1                             |
| 050-012-00-5 | tetracyclohexylstannane [1]<br>chlorotricyclohexylstannane [2]<br>butyltricyclohexylstannane [3]   | A                           | 215-910-5 [1]<br>221-437-5 [2]<br>230-358-5 [3] | 1449-55-4 [1]<br>3091-32-5 [2]<br>7067-44-9 [3] | Xn; R20/21/22<br>N; R50-53        | Xn; N<br>R: 20/21/22-50/53<br>S: (2-)26-28-60-61         | C ≥ 25 %: Xn, N; R20/21/22-50/53<br>2,5 % ≤ C < 25 %: Xn, N; R20/21/22-51/53<br>1 % ≤ C < 2,5 %: Xn; R20/21/22-52/53<br>0,25 % ≤ C < 1 %: R52/53  | 1                             |
| 050-013-00-0 | trioctyltin compounds, with the exception of those specified elsewhere in this Annex   | A                           | —   | —   | Xi; R36/37/38<br>R53              | Xi<br>R: 36/37/38-53<br>S: (2-)61                        | C ≥ 25 %: Xi; R36/37/38-53<br>1 % ≤ C < 25 %: Xi; R36/37/38   | 1                             |
| 051-002-00-3 | antimony pentachloride   |                             | 231-601-8                                       | 7647-18-9                                       | C; R34<br>N; R51-53               | C; N<br>R: 34-51/53<br>S: (1/2-)26-45-61                 | C ≥ 25 %: C, N; R34-51/53<br>10 % ≤ C < 25 %: C; R34-52/53<br>5 % ≤ C < 10 %: Xi; R36/37/38-52/53<br>2,5 % ≤ C < 5 %: R52/53  |                               |
| 051-003-00-9 | antimony compounds, with the exception of the tetroxide (Sb <sub>2</sub> O <sub>4</sub> ), pentoxide (Sb <sub>2</sub> O <sub>5</sub> ), trisulphide (Sb <sub>2</sub> S <sub>3</sub> ), pentasulphide (Sb <sub>2</sub> S <sub>5</sub> ) and those specified elsewhere in this Annex | A                           | —   | —   | Xn; R20/22<br>N; R51-53           | Xn; N<br>R: 20/22-51/53<br>S: (2-)61                     | C ≥ 25 %: Xn, N; R20/22-51/53<br>2,5 % ≤ C < 25 %: Xn; R20/22-52/53<br>0,25 % ≤ C < 2,5 %: Xn; R20/22   | 1                             |
| 080-002-00-6 | inorganic compounds of mercury with the exception of mercuric sulphide and those specified elsewhere in this Annex   | A                           | —   | —   | T+; R26/27/28<br>R33<br>N; R50-53 | T+; N<br>R: 26/27/28-33-50/53<br>S: (1/2-)13-28-45-60-61 | C ≥ 25 %: T+, N; R26/27/28-33-50/53<br>2,5 % ≤ C < 25 %: T+, N; R26/27/28-33-51/53<br>2 % ≤ C < 2,5 %: T+; R26/27/28-33-52/53<br>0,5 % ≤ C < 2 %: T; R23/24/25-33-52/53<br>0,25 % ≤ C < 0,5 %: Xn; R20/21/22-33-52/53<br>0,1 % ≤ C < 0,25 %: Xn; R20/21/22-33 | 1                             |

| Index No     | chemical name  | Notes related to substances | EC No                          | CAS No                       | Classification  | Labelling   | Concentration Limits  | Notes related to preparations |
|--------------|--|-----------------------------|--------------------------------|------------------------------|---|---|---|-------------------------------|
| 080-004-00-7 | organic compounds of mercury with the exception of those specified elsewhere in this Annex | A                           | —                              | —                            | T+; R26/27/28<br>R33<br>N; R50-53   | T+; N<br>R: 26/27/28-33-50/53<br>S: (1/2-)13-28-36-45-60-61 | C ≥ 25 %: T+, N; R26/27/28-33-50/53<br>2,5 % ≤ C < 25 %: T+, N; R26/27/28-33-51/53<br>1 % ≤ C < 2,5 %: T+; R26/27/28-33-52/53<br>0,5 % ≤ C < 1 %: T; R23/24/25-33-52/53<br>0,25 % ≤ C < 0,5 %: Xn; R20/21/22-33-52/53<br>0,05 % ≤ C < 0,25 %: Xn; R20/21/22-33  | 1                             |
| 080-007-00-3 | dimethylmercury [1]<br>diethylmercury [2]  |                             | 209-805-3 [1]<br>211-000-7 [2] | 593-74-8 [1]<br>627-44-1 [2] | T+; R26/27/28<br>R33<br>N; R50-53   | T+; N<br>R: 26/27/28-33-50/53<br>S: (1/2-)13-28-36-45-60-61 | C ≥ 25 %: T+, N; R26/27/28-33-50/53<br>2,5 % ≤ C < 25 %: T+, N; R26/27/28-33-51/53<br>0,5 % ≤ C < 2,5 %: T+; R26/27/28-33-52/53<br>0,25 % ≤ C < 0,5 %: T; R23/24/25-33-52/53<br>0,1 % ≤ C < 0,25 %: T; R23/24/25-33<br>0,05 % ≤ C < 0,1 %: Xn; R20/21/22-33   | 1                             |
| 082-001-00-6 | lead compounds with the exception of those specified elsewhere in this Annex               | AE                          | —                              | —                            | Repr. Cat. 1; R61<br>Repr. Cat. 3; R62<br>Xn; R20/22<br>R33<br>N; R50-53    | T; N<br>R: 61-20/22-33-62-50/53<br>S: 53-45-60-61           | C ≥ 25 %: T, N; R61-20/22-33-62-50/53<br>5 % ≤ C < 25 %: T, N; R61-20/22-33-62-51/53<br>2,5 % ≤ C < 5 %: T, N; R61-20/22-33-62-51/53<br>1 % ≤ C < 2,5 %: T; R61-20/22-33-52/53<br>0,5 % ≤ C < 1 %: T; R61-33-52/53<br>0,25 % ≤ C < 0,5 %: R52/53  | 1                             |
| 082-002-00-1 | lead alkyls  | AE                          | —                              | —                            | Repr. Cat. 1; R61<br>Repr. Cat. 3; R62<br>T+; R26/27/28<br>R33<br>N; R50-53 | T+; N<br>R: 61-26/27/28-33-62-50/53<br>S: 53-45-60-61       | C ≥ 25 %: T+, N; R61-26/27/28-33-62-50/53<br>5 % ≤ C < 25 %: T+, N; R61-26/27/28-33-62-51/53<br>2,5 % ≤ C < 5 %: T+, N; R61-26/27/28-33-51/53<br>0,5 % ≤ C < 2,5 %: T+; R61-26/27/28-33-52/53<br>0,25 % ≤ C < 0,5 %: T; R61-26/27/28-33-52/53<br>0,1 % ≤ C < 0,25 %: T; R61-23/24/25-33<br>0,05 % ≤ C < 0,1 %: Xn; R20/21/22-33 | 1                             |

| Index No     | chemical name                                   | Notes related to substances | EC No     | CAS No   | Classification   | Labelling  | Concentration Limits                                      | Notes related to preparations |
|--------------|---|-----------------------------|-----------|----------|--|--|---|-------------------------------|
| 601-010-00-3 | ethylene  |                             | 200-815-3 | 74-85-1  | F+; R12<br>R67   | F+<br>R: 12-67<br>S: (2-)9-16-33-46                            |   |                               |
| 601-014-00-5 | isoprene (stabilized)<br>2-methyl-1,3-butadiene | D                           | 201-143-3 | 78-79-5  | F+; R12<br>Carc. Cat. 2; R45<br>Muta. Cat. 3; R68<br>R52-53                                  | F+; T<br>R: 45-12-68-52/53<br>S: 53-45-61                      |   |                               |
| 601-017-00-1 | cyclohexane                                     |                             | 203-806-2 | 110-82-7 | F; R11<br>Xn; R65<br>Xi; R38<br>R67<br>N; R50-53   | F; Xn; N<br>R: 11-38-65-67-50/53<br>S: (2-)9-16-25-33-60-61-62 |   | 4 6                           |
| 601-020-00-8 | benzene   | E                           | 200-753-7 | 71-43-2  | F; R11<br>Carc. Cat. 1; R45<br>Muta. Cat. 2; R46<br>T; R48/23/24/25<br>Xn; R65<br>Xi; R36/38 | F; T<br>R: 45-46-11-36/38-48/<br>23/24/25-65<br>S: 53-45       |   |                               |
| 601-021-00-3 | toluene   |                             | 203-625-9 | 108-88-3 | F; R11<br>Repr.Cat.3; R63<br>Xn; R48/20-65<br>Xi; R38<br>R67                                 | F; Xn<br>R: 11-38-48/20-63-65-67<br>S: (2-)36/37-62-46         |   | 4, 6                          |
| 601-025-00-5 | mesitylene<br>1,3,5-trimethylbenzene            |                             | 203-604-4 | 108-67-8 | R10<br>Xi; R37<br>N; R51-53  | Xi; N<br>R: 10-37-51/53<br>S: (2-)61                           | C ≥ 25 %: Xi, N; R37-51/53<br>2,5 % ≤ C < 25 %: R52/53    |                               |
| 601-027-00-6 | 2-phenylpropene<br>α-methylstyrene              |                             | 202-705-0 | 98-83-9  | R10<br>Xi; R36/37<br>N; R51-53   | Xi; N<br>R: 10-36/37-51/53<br>S: (2-)61                        | C ≥ 25 %: Xi, N; R36/37-51/53<br>2,5 % ≤ C < 25 %: R52/53 |                               |
| 601-028-00-1 | 2-methylstyrene<br>2-vinyltoluene               |                             | 210-256-7 | 611-15-4 | Xn; R20<br>N; R51-53   | Xn; N<br>R: 20-51/53<br>S: (2-)24-61                           | C ≥ 25 %: Xn, N; R20-51/53<br>2,5 % ≤ C < 25 %: R52/53    |                               |



| Index No     | chemical name  | Notes related to substances | EC No                          | CAS No                              | Classification   | Labelling  | Concentration Limits  | Notes related to preparations |
|--------------|--|-----------------------------|--------------------------------|-------------------------------------|--|--|---|-------------------------------|
| 601-032-00-3 | benzo[ <i>a</i> ]pyrene<br>benzo[ <i>def</i> ]chrysene |                             | 200-028-5                      | 50-32-8                             | Carc. Cat. 2; R45<br>Muta. Cat. 2; R46<br>Repr. Cat. 2; R60-61<br>R43<br>N; R50-53 | T; N<br>R: 45-46-60-61-43-50/<br>53<br>S: 53-45-60-61                              | C ≥ 25 %: T, N; R43-45-46-50-53-60-61<br>2,5 % ≤ C < 25 %: T, N; R43-45-46-51-<br>53-60-61<br>1 % ≤ C < 2,5 %: T; R43-45-46-52-53-<br>60-61<br>0,5 % ≤ C < 1 %: T; R45-46-52-53-60-61<br>0,25 % ≤ C < 0,5 %: T; R45-46-52-53<br>0,1 % ≤ C < 0,25 %: T; R45-46<br>0,01 % ≤ C < 0,1 %: T; R45 |                               |
| 601-037-00-0 | n-hexane   |                             | 203-777-6                      | 110-54-3                            | F; R11<br>Repr. Cat. 3; R62<br>Xn; R65-48/20<br>Xi; R38<br>R67<br>N; R51-53        | F; Xn; N<br>R: 11-38-48/20-62-65-<br>67-51/53<br>S: (2-)9-16-29-33-36/37-<br>61-62 | C ≥ 25 %: Xn, N; R38-48/20-62-51/53<br>20 % ≤ C < 25 %: Xn; R38-48/20-62-52/<br>53<br>5 % ≤ C < 20 %: Xn; R48/20-62-52/53<br>2,5 % ≤ C < 5 %: R52/53  | 4 6                           |
| 601-041-00-2 | dibenz[ <i>a,h</i> ]anthracene                         |                             | 200-181-8                      | 53-70-3                             | Carc. Cat. 2; R45<br>N; R50-53   | T; N<br>R: 45-50/53<br>S: 53-45-60-61  | C ≥ 25 %: T, N; R45-50/53<br>2,5 % ≤ C < 25 %: T, N; R45-51/53<br>0,25 % ≤ C < 2,5 %: T; R45-52/53<br>0,01 % ≤ C < 0,25 %: T; R45   |                               |
| 601-048-00-0 | chrysene   |                             | 205-923-4                      | 218-01-9                            | Carc. Cat. 2; R45<br>Muta. Cat. 3; R68<br>N; R50-53                                | T; N<br>R: 45-68-50/53<br>S: 53-45-60-61   |   |                               |
| 601-052-00-2 | naphthalene  |                             | 202-049-5                      | 91-20-3                             | Carc. Cat.3; R40<br>Xn; R22<br>N; R50-53   | Xn; N<br>R: 22-40-50/53<br>S: (2-)36/37-46-60-61                                   |   |                               |
| 601-053-00-8 | nonylphenol<br>[1]<br>4-nonylphenol, branched<br>[2]   |                             | 246-672-0 [1]<br>284-325-5 [2] | 25154-52-3 [1]<br>84852-15-3<br>[2] | Repr.Cat.3; R62<br>Repr.Cat.3; R63<br>Xn; R22<br>C; R34<br>N; R50-53               | C; N<br>R: 22-34-62-63-50/53<br>S: (1/2-)26-36/37/39-45-<br>46-60-61               |   |                               |
| 602-003-00-8 | dibromomethane   |                             | 200-824-2                      | 74-95-3                             | Xn; R20<br>R52-53  | Xn<br>R: 20-52/53<br>S: (2-)24-61  | C ≥ 25 %: Xn; R20-52/53<br>12,5 % ≤ C < 25 %: Xn; R20   |                               |
| 602-008-00-5 | carbon tetrachloride<br>tetrachloromethane             |                             | 200-262-8                      | 56-23-5                             | Carc. Cat. 3; R40<br>T; R23/24/25-48/23<br>R52-53<br>N; R59                        | T; N<br>R: 23/24/25-40-48/23-<br>59-52/53<br>S: (1/2-)23-36/37-45-59-<br>61        | C ≥ 25 %: T, N; R23/24/25-40-48/23-52/<br>53-59<br>1 % ≤ C < 25 %: T, N; R23/24/25-40-48/<br>23-59<br>0,2 % ≤ C < 1 %: Xn, N; R20/21/22-48/<br>20-59<br>0,1 % ≤ C < 0,2 %: N; R59   |                               |

| Index No     | chemical name                      | Notes related to substances | EC No     | CAS No   | Classification   | Labelling  | Concentration Limits  | Notes related to preparations |
|--------------|------------------------------------|-----------------------------|-----------|----------|--|--|---|-------------------------------|
| 602-010-00-6 | 1,2-dibromoethane                  | E                           | 203-444-5 | 106-93-4 | Carc. Cat. 2; R45<br>T; R23/24/25<br>Xi; R36/37/38<br>N; R51-53                      | T; N<br>R: 45-23/24/25-36/37/<br>38-51/53<br>S: 53-45-61 | C ≥ 25 %: T, N; R45-23/24/25-36/37/38-51/53<br>20 % ≤ C < 25 %: T, N; R45-23/24/25-36/37/38-52/53<br>2,5 % ≤ C < 20 %: T, N; R45-23/24/25-52/53<br>1 % ≤ C < 2,5 %: T; R45-23/24/25<br>0,1 % ≤ C < 1 %: T; R45-20/21/22 |                               |
| 602-011-00-1 | 1,1-dichloroethane                 |                             | 200-863-5 | 75-34-3  | F; R11<br>Xn; R22<br>Xi; R36/37<br>R52-53  | F; Xn<br>R: 11-22-36/37-52/53<br>S: (2-)16-23-61         | C ≥ 25 %: Xn; R22-36/37-52/53<br>20 % ≤ C < 25 %: Xn; R22-36/37<br>12,5 % ≤ C < 20 %: Xn; R22   |                               |
| 602-014-00-8 | 1,1,2-trichloroethane              |                             | 201-166-9 | 79-00-5  | Carc.Cat.3; R40<br>Xn; R20/21/22<br>R66  | Xn<br>R: 20/21/22-40-66<br>S: (2-)9-36/37-46             | C ≥ 5 %: Xn; R20/21/22  |                               |
| 602-015-00-3 | 1,1,2,2-tetrachloroethane          |                             | 201-197-8 | 79-34-5  | T+; R26/27<br>N; R51-53  | T+; N<br>R: 26/27-51/53<br>S: (1/2-)38-45-61             | C ≥ 25 %: T+, N; R26/27-51/53<br>7 % ≤ C < 25 %: T+; R26/27-52/53<br>2,5 % ≤ C < 7 %: T; R23/24-52/53<br>1 % ≤ C < 2,5 %: T; R23/24<br>0,1 % ≤ C < 1 %: Xn; R20/21  |                               |
| 602-016-00-9 | 1,1,2,2-tetrabromoethane           |                             | 201-191-5 | 79-27-6  | T+; R26<br>Xi; R36<br>R52-53   | T+<br>R: 26-36-52/53<br>S: (1/2-)24-27-45-61             | C ≥ 25 %: T+; R26-36-52/53<br>20 % ≤ C < 25 %: T+; R26-36<br>7 % ≤ C < 20 %: T+; R26<br>1 % ≤ C < 7 %: T; R23<br>0,1 % ≤ C < 1 %: Xn; R20   |                               |
| 602-017-00-4 | pentachloroethane                  |                             | 200-925-1 | 76-01-7  | Carc. Cat. 3; R40<br>T; R48/23<br>N; R51-53  | T; N<br>R: 40-48/23-51/53<br>S: (1/2-)23-36/37-45-61     | C ≥ 25 %: T, N; R40-48/23-51/53<br>2,5 % ≤ C < 25 %: T; R40-48/23-52/53<br>1 % ≤ C < 2,5 %: T; R40-48/23<br>0,2 % ≤ C < 1 %: Xn; R48/20   |                               |
| 602-019-00-5 | 1-bromopropane<br>n-propyl bromide |                             | 203-445-0 | 106-94-5 | F; R11<br>Rep. Cat. 2; R60<br>Rep. Cat. 3; R63<br>Xn; R48/20<br>Xi; R36/37/38<br>R67 | T; F<br>R: 60-11-36/37/38-48/<br>20-63-67<br>S: 53-45    |   |                               |

| Index No     | chemical name   | Notes related to substances | EC No   | CAS No                                       | Classification   | Labelling   | Concentration Limits  | Notes related to preparations |
|--------------|---|-----------------------------|---|--|--|---|---|-------------------------------|
| 602-025-00-8 | 1,1-dichloroethylene<br>vinylidene chloride   | D                           | 200-864-0                                       | 75-35-4                                      | F; R12<br>Carc.Cat.3; R40<br>Xn; R20   | F+; Xn<br>R: 12-20-40<br>S: (2-)7-16-29-36/37-46  | C ≥ 12,5 %: Xn; R20-40<br>1 % ≤ C < 12,5 %: Xn; R40   |                               |
| 602-026-00-3 | 1,2-dichloroethylene<br>[1]<br><i>cis</i> -dichloroethylene<br>[2]<br><i>trans</i> -dichloroethylene<br>[3] | C                           | 208-750-2 [1]<br>205-859-7 [2]<br>205-860-2 [3] | 540-59-0 [1]<br>156-59-2 [2]<br>156-60-5 [3] | F; R11<br>Xn; R20<br>R52-53  | F; Xn<br>R: 11-20-52/53<br>S: (2-)7-16-29-61  | C ≥ 25 %: Xn; R20-52/53<br>12,5 % ≤ C < 25 %: Xn; R20   |                               |
| 602-029-00-X | 3-chloropropene<br>allyl chloride   | D                           | 203-457-6                                       | 107-05-1                                     | F; R11<br>Carc.Cat.3; R40<br>Muta.Cat.3; R68<br>Xn; R20/21/22-48/20<br>Xi; R36/37/38<br>N; R50 | F; Xn; N<br>R: 11-20/21/22-36/37/<br>38-40-48/20-68-50<br>S: (2-)16-25-26-36/37-<br>46-61 |   |                               |
| 602-033-00-1 | chlorobenzene   |                             | 203-628-5                                       | 108-90-7                                     | R10<br>Xn; R20<br>N; R51-53  | Xn; N<br>R: 10-20-51/53<br>S: (2-)24/25-61  | C ≥ 25 %: Xn, N; R20-51/53<br>5 % ≤ C < 25 %: Xn, N; R20-52/53<br>2,5 % ≤ C < 5 %: R52/53   |                               |
| 602-034-00-7 | 1,2-dichlorobenzene<br><i>o</i> -dichlorobenzene  |                             | 202-425-9                                       | 95-50-1                                      | Xn; R22<br>Xi; R36/37/38<br>N; R50-53  | Xn; N<br>R: 22-36/37/38-50/53<br>S: (2-)23-60-61  | C ≥ 25 %: Xn, N; R22-36/37/38-50/53<br>20 % ≤ C < 25 %: Xn, N; R22-36/37/38-<br>51/53<br>5 % ≤ C < 20 %: Xn, N; R22-51/53<br>2,5 % ≤ C < 5 %: N; R51/53<br>0,25 % ≤ C < 2,5 %: R52/53 |                               |
| 602-035-00-2 | 1,4-dichlorobenzene<br><i>p</i> -dichlorobenzene  |                             | 203-400-5                                       | 106-46-7                                     | Xi; R36<br>Carc. Cat. 3; R40<br>N; R50-53  | Xn; N<br>R: 36-40-50/53<br>S: (2-)36/37-46-60-61  |   |                               |
| 602-036-00-8 | chloroprene (stabilized)<br>2-chlorobuta-1,3-diene  | D E                         | 204-818-0                                       | 126-99-8                                     | F; R11<br>Carc. Cat. 2; R45<br>Xn; R20/22-48/20<br>Xi; R36/37/38                               | F; T<br>R: 45-11-20/22-36/37/<br>38-48/20<br>S: 53-45                                     |   |                               |
| 602-039-00-4 | polychlorobiphenyls<br>PCB  | C                           | 215-648-1                                       | 1336-36-3                                    | R33<br>N; R50-53   | Xn; N<br>R: 33-50/53<br>S: (2-)35-60-61   | C ≥ 25 %: Xn, N; R33-50/53<br>2,5 % ≤ C < 25 %: Xn, N; R33-51/53<br>0,25 % ≤ C < 2,5 %: Xn, N; R33-52/53<br>0,005 % ≤ C < 0,25 %: Xn; R33   |                               |

| Index No     | chemical name  | Notes related to substances | EC No     | CAS No     | Classification   | Labelling   | Concentration Limits  | Notes related to preparations |
|--------------|--|-----------------------------|-----------|------------|--|---|---|-------------------------------|
| 602-043-00-6 | $\gamma$ -HCH or $\gamma$ -BHC<br>$\gamma$ -1,2,3,4,5,6-hexachlorocyclohexane<br>lindane |                             | 200-401-2 | 58-89-9    | T; R25<br>Xn; R20/21-48/22<br>R64<br>N; R50-53                   | T; N<br>R: 20/21-25-48/22-64-50/53<br>S: (1/2-)36/37-45-60-61 | C $\geq$ 25 %: T, N; R20/21-25-48/22-64-50-53<br>10 % $\leq$ C < 25 %: Xn, N; R22-48/22-64-50-53<br>3 % $\leq$ C < 10 %: Xn, N; R22-64-50-53<br>2,5 % $\leq$ C < 3 %: N; R64-50-53<br>1 % $\leq$ C < 2,5 %: N; R64-51-53<br>0,25 % $\leq$ C < 1 %: N; R51-53<br>0,025 % $\leq$ C < 0,25 %: R52-53   |                               |
| 602-062-00-X | 1,2,3-trichloropropane   | D                           | 202-486-1 | 96-18-4    | Carc. Cat. 2; R45<br>Repr. Cat. 2; R60<br>Xn; R20/21/22          | T<br>R: 45-60-20/21/22<br>S: 53-45                            |   |                               |
| 602-073-00-X | 1,4-dichlorobut-2-ene  | E                           | 212-121-8 | 764-41-0   | Carc. Cat. 2; R45<br>T+; R26<br>T; R24/25<br>C; R34<br>N; R50-53 | T+; N<br>R: 45-24/25-26-34-50/53<br>S: 53-45-60-61            | C $\geq$ 25 %: T+, N; R45-24/25-26-34-50/53<br>10 % $\leq$ C < 25 %: T+, N; R45-21/22-26-34-51/53<br>7 % $\leq$ C < 10 %: T+, N; R45-21/22-26-36/37/38-51/53<br>5 % $\leq$ C < 7 %: T, N; R45-21/22-23-36/37/38-51/53<br>3 % $\leq$ C < 5 %: T, N; R45-21/22-23-51/53<br>2,5 % $\leq$ C < 3 %: T, N; R45-23-51/53<br>1 % $\leq$ C < 2,5 %: T; R45-23-52/53<br>0,25 % $\leq$ C < 1 %: T; R45-20-52/53<br>0,1 % $\leq$ C < 0,25 %: T; R45-20<br>0,01 % $\leq$ C < 0,1 %: T; R45 |                               |
| 603-006-00-7 | pentanol isomers, with the exception fo those specified elsewhere in this Annex          | C                           | 250-378-8 | 30899-19-5 | R10<br>Xn; R20<br>Xi; R37<br>R66                                 | Xn<br>R: 10-20-37-66<br>S: (2-)46                             |   |                               |
| 603-007-00-2 | 2-methylbutan-2-ol<br>tert-pentanol  |                             | 200-908-9 | 75-85-4    | F; R11<br>Xn; R20<br>Xi; R37/38                                  | F; Xn<br>R: 11-20-37/38<br>S: (2-)46                          |   |                               |
| 603-029-00-2 | bis(2-chloroethyl) ether   |                             | 203-870-1 | 111-44-4   | R10<br>Carc.Cat.3; R40<br>T+; R26/27/28                          | T+<br>R: 10-26/27/28-40<br>S: (1/2-)7/9-27-28-36/37-45        | C $\geq$ 7 %: T+; R26/27/28-40<br>1 % $\leq$ C < 7 %: T; R23/24/25-40<br>0,1 % $\leq$ C < 1 %: Xn; R20/21/22  |                               |
| 603-030-00-8 | 2-aminoethanol<br>ethanolamine   |                             | 205-483-3 | 141-43-5   | Xn; R20/21/22<br>C; R34  | C<br>R: 20/21/22-34<br>S: (1/2-)26-36/37/39-45                | C $\geq$ 25 %: C; R20/21/22-34<br>10 % $\leq$ C < 25 %: C; R34<br>5 % $\leq$ C < 10 %: Xi; R36/37/38  |                               |

| Index No     | chemical name  | Notes related to substances | EC No     | CAS No     | Classification   | Labelling  | Concentration Limits   | Notes related to preparations |
|--------------|--|-----------------------------|-----------|------------|--|--|--|-------------------------------|
| 603-031-00-3 | 1,2-dimethoxyethane<br>ethylene glycol dimethyl ether<br>EGDME   |                             | 203-794-9 | 110-71-4   | Repr.Cat.2; R60<br>Repr.Cat.2; R61<br>F; R11<br>R19<br>Xn; R20                                       | F; T<br>R: 60-61-11-19-20<br>S: 53-45                                    |  |                               |
| 603-054-00-9 | di-n-butyl ether<br>dibutyl ether  |                             | 205-575-3 | 142-96-1   | R10<br>Xi; R36/37/38<br>R52-53   | Xi<br>R: 10-36/37/38-52/53<br>S: (2-)61                                  | C ≥ 10 %: Xi; R36/37/38  |                               |
| 603-063-00-8 | 2,3-epoxypropan-1-ol<br>glycidol<br>oxiranemethanol  | E                           | 209-128-3 | 556-52-5   | Carc. Cat. 2; R45<br>Muta. Cat. 3; R68<br>Repr. Cat. 2; R60<br>T; R23<br>Xn; R21/22<br>Xi; R36/37/38 | T<br>R: 45-60-21/22-23-36/<br>37/38-68<br>S: 53-45                       |  |                               |
| 603-066-00-4 | 1,2-epoxy-4-epoxyethylcyclohexane<br>vinylcyclohexane diepoxide  |                             | 203-437-7 | 106-87-6   | T; R23/24/25<br>Xn; R68  | T<br>R: 23/24/25-68<br>S: (1/2-)23-24-45                                 | C ≥ 1 %: T; R23/24/25-68<br>0,1 % ≤ C < 1 %: Xn; R20/21/22   |                               |
| 603-067-00-X | phenyl glycidyl ether<br>2,3-epoxypropyl phenyl ether<br>1,2-epoxy-3-phenoxypropane                          | E                           | 204-557-2 | 122-60-1   | Carc. Cat. 2; R45<br>Muta. Cat. 3; R68<br>Xn; R20<br>Xi; R37/38<br>R43<br>R52-53                     | T<br>R: 45-20-37/38-43-68-<br>52/53<br>S: 53-45-61                       |  |                               |
| 603-070-00-6 | 2-amino-2-methylpropanol   |                             | 204-709-8 | 124-68-5   | Xi; R36/38<br>R52-53   | Xi<br>R: 36/38-52/53<br>S: (2-)61  | C ≥ 25 %: Xi; R36/38-52/53<br>10 % ≤ C < 25 %: Xi; R36/38  |                               |
| 603-074-00-8 | reaction product: bisphenol-A-<br>(epichlorhydrin)<br>epoxy resin (number average<br>molecular weight ≤ 700) |                             | 500-033-5 | 25068-38-6 | Xi; R36/38<br>R43<br>N; R51-53   | Xi; N<br>R: 36/38-43-51/53<br>S: (2-)28-37/39-61                         | C ≥ 25 %: Xi, N; R36/38-43-51/53<br>5 % ≤ C < 25 %: Xi; R36/38-43-52/53<br>2,5 % ≤ C < 5 %: Xi; R43-52/53<br>1 % ≤ C < 2,5 %: Xi; R43  |                               |
| 603-076-00-9 | but-2-yne-1,4-diol<br>2-butyne-1,4-diol  | D                           | 203-788-6 | 110-65-6   | C; R34<br>T; R23/25<br>Xn; R21-48/22<br>R43  | C; T<br>R: 21-23/25-34-43-48/<br>22<br>S: (1/2-)25-26-36/37/39-<br>45-46 | C ≥ 50 %: T, C; R21-23/25-34-48/22-43<br>25 % ≤ C < 50 %: T; R21-23/25-36/38-<br>48/22-43<br>10 % ≤ C < 25 %: Xn; R20/22-48/22-43<br>3 % ≤ C < 10 %: Xn; R20/22-43<br>1 % ≤ C < 3 %: Xi; R43 |                               |

| Index No     | chemical name   | Notes related to substances | EC No     | CAS No    | Classification  | Labelling   | Concentration Limits  | Notes related to preparations |
|--------------|---|-----------------------------|-----------|-----------|---|---|---|-------------------------------|
| 603-095-00-2 | 2-(propyloxy)ethanol<br>EGPE  |                             | 220-548-6 | 2807-30-9 | Xn; R21<br>Xi; R36  | Xn<br>R: 21-36<br>S: (2-)26-36/37-46  |   |                               |
| 603-105-00-5 | furan   | E                           | 203-727-3 | 110-00-9  | F+; R12<br>R19<br>Carc. Cat. 2; R45<br>Muta. Cat. 3; R68<br>Xn; R20/22-48/22<br>Xi; R38<br>R52-53 | F+; T<br>R: 45-12-19-20/22-38-48/22-68-52/53<br>S: 53-45-61                       |   |                               |
| 604-001-00-2 | phenol<br>carbolic acid<br>monohydroxybenzene<br>phenylalcohol        |                             | 203-632-7 | 108-95-2  | Muta.Cat.3; R68<br>T; R23/24/25<br>Xn; R48/20/21/22<br>C; R34                                     | T; C<br>R: 23/24/25-34-48/20/<br>21/22-68<br>S: (1/2-)24/25-26-28-36/<br>37/39-45 | C ≥ 10 %: T; R23/24/25-48/20/21/22-34-68<br>3 % ≤ C < 10 %: C ; Xn ; R20/21/22-34-68<br>1 % ≤ C < 3 %: Xn ; R36/38-68   |                               |
| 604-009-00-6 | pyrogallol<br>1,2,3-trihydroxybenzene                                 |                             | 201-762-9 | 87-66-1   | Muta. Cat. 3; R68<br>Xn; R20/21/22<br>R52-53  | Xn<br>R: 20/21/22-68-52/53<br>S: (2-)36/37-61                                     | C ≥ 25 %: Xn; R20/21/22-68-52/53<br>10 % ≤ C < 25 %: Xn; R20/21/22-68<br>1 % ≤ C < 10 %: Xn; R68  |                               |
| 604-010-00-1 | resorcinol<br>1,3-benzenediol   |                             | 203-585-2 | 108-46-3  | Xn; R22<br>Xi; R36/38<br>N; R50   | Xn; N<br>R: 22-36/38-50<br>S: (2-)26-61   | C ≥ 25 %: Xn, N; R22-36/38-50<br>20 % ≤ C < 25 %: Xn; R22-36/38<br>10 % ≤ C < 20 %: Xn; R22   |                               |
| 604-012-00-2 | 4-chloro- <i>o</i> -cresol<br>4-chloro-2-methyl phenol                |                             | 216-381-3 | 1570-64-5 | T; R23<br>C; R35<br>N; R50  | T; C; N<br>R: 23-35-50<br>S: (1/2-)26-36/37/39-45-61                              | C ≥ 25 %: T, C, N; R23-35-50<br>10 % ≤ C < 25 %: C; R20-35<br>5 % ≤ C < 10 %: C; R20-34<br>3 % ≤ C < 5 %: Xn; R20-36/37/38<br>1 % ≤ C < 3 %: Xi; R36/37/38  |                               |
| 604-013-00-8 | 2,3,4,6-tetrachlorophenol   |                             | 200-402-8 | 58-90-2   | T; R25<br>Xi; R36/38<br>N; R50-53   | T; N<br>R: 25-36/38-50/53<br>S: (1/2-)26-28-37-45-60-61                           | C ≥ 25 %: T, N; R25-36/38-50/53<br>20 % ≤ C < 25 %: T, N; R25-51/53<br>5 % ≤ C < 20 %: T, N; R25-36/38-51/53<br>2,5 % ≤ C < 5 %: Xn, N; R22-51/53<br>0,5 % ≤ C < 2,5 %: Xn; R22-52/53<br>0,25 % ≤ C < 0,5 %: R52/53 |                               |
| 604-014-00-3 | chlorocresol<br>4-chloro- <i>m</i> -cresol<br>4-chloro-3-methylphenol |                             | 200-431-6 | 59-50-7   | Xn; R21/22<br>Xi; R41<br>R43<br>N; R50  | Xn; N<br>R: 21/22-41-43-50<br>S: (2-)26-36/37/39-61                               | C ≥ 25 %: Xn, N; R21/22-41-43-50<br>10 % ≤ C < 25 %: Xn; R21/22-41-43<br>5 % ≤ C < 10 %: Xn; R21/22-36-43<br>1 % ≤ C < 5 %: Xi; R43   |                               |

| Index No     | chemical name  | Notes related to substances | EC No     | CAS No   | Classification  | Labelling  | Concentration Limits  | Notes related to preparations |
|--------------|--|-----------------------------|-----------|----------|---|--|---|-------------------------------|
| 604-015-00-9 | 2,2'-methylenebis-(3,4,6-trichlorophenol)<br>hexachlorophene |                             | 200-733-8 | 70-30-4  | T; R24/25<br>N; R50-53  | T; N<br>R: 24/25-50/53<br>S: (1/2-)20-37-45-60-61              | C ≥ 25 %: T, N; R24/25-50/53<br>2,5 % ≤ C < 25 %: T, N; R24/25-51/53<br>2 % ≤ C < 2,5 %: T; R24/25-52/53<br>0,25 % ≤ C < 2 %: Xn; R21/22-52/53<br>0,2 % ≤ C < 0,25 %: Xn; R21/22  |                               |
| 604-017-00-X | 2,4,5-trichlorophenol  |                             | 202-467-8 | 95-95-4  | Xn; R22<br>Xi; R36/38<br>N; R50-53                            | Xn; N<br>R: 22-36/38-50/53<br>S: (2-)26-28-60-61               | C ≥ 25 %: Xn, N; R22-36/38-50/53<br>20 % ≤ C < 25 %: Xn, N; R22-36/38-51/53<br>5 % ≤ C < 20 %: Xn, N; R36/38-51/53<br>2,5 % ≤ C < 5 %: N; R51/53<br>0,25 % ≤ C < 2,5 %: R52/53  |                               |
| 604-030-00-0 | bisphenol A<br>4,4'-isopropylidenediphenol                   |                             | 201-245-8 | 80-05-7  | Repr. Cat. 3; R62<br>Xi; R37-41<br>R43                        | Xn<br>R: 37-41-43-62<br>S: (2-)26-36/37-39-46                  |   |                               |
| 605-002-00-0 | 1,3,5-trioxan<br>trioxymethylene                             |                             | 203-812-5 | 110-88-3 | F; R11<br>Repr.Cat.3; R63<br>Xi; R37                          | F; Xn<br>R: 11-37-63<br>S: (2-)36/37-46                        |   |                               |
| 605-016-00-7 | glyoxal...%<br>ethandial...%                                 | B                           | 203-474-9 | 107-22-2 | Muta. Cat. 3; R68<br>Xn; R20<br>Xi; R36/38<br>R43             | Xn<br>R: 20-36/38-43-68<br>S: (2-)36/37                        | C ≥ 10 %: Xn; R20-36/38-43-68<br>1 % ≤ C < 10 %: Xn; R43-68   |                               |
| 605-020-00-9 | safrole<br>5-allyl-1,3-benzodioxole                          | E                           | 202-345-4 | 94-59-7  | Carc. Cat. 2; R45<br>Muta. Cat. 3; R68<br>Xn; R22             | T<br>R: 45-22-68<br>S: 53-45                                   |   |                               |
| 605-022-00-X | glutaral<br>glutaraldehyde<br>1,5-pentanedial                |                             | 203-856-5 | 111-30-8 | T; R23/25<br>C; R34<br>R42/43<br>N; R50                       | T; N<br>R: 23/25-34-42/43-50<br>S: (1/2-)26-36/37/39-45-61     | C ≥ 50 %: T, N; R23/25-34-42/43-50<br>25 % ≤ C < 50 %: T; R22-23-34-42/43<br>10 % ≤ C < 25 %: C; R20/22-34-42/43<br>2 % ≤ C < 10 %: Xn; R20/22-37/38-41-42/43<br>1 % ≤ C < 2 %: Xn; R36/37/38-42/43<br>0,5 % ≤ C < 1 %: Xi; R36/37/38-43                      |                               |
| 605-025-00-6 | chloroacetaldehyde   |                             | 203-472-8 | 107-20-0 | Carc. Cat. 3; R40<br>T+; R26<br>T; R24/25<br>C; R34<br>N; R50 | T+; N<br>R: 24/25-26-34-40-50<br>S: (1/2-)26-28-36/37/39-45-61 | C ≥ 25 %: T+, N; R24/25-26-34-40-50<br>10 % ≤ C < 25 %: T+; R21/22-26-34-40<br>7 % ≤ C < 10 %: T+; R21/22-26-36/37/38-40<br>5 % ≤ C < 7 %: T; R21/22-23-36/37/38-40<br>3 % ≤ C < 5 %: T; R21/22-23-40<br>1 % ≤ C < 3 %: T; R23-40<br>0,1 % ≤ C < 1 %: Xn; R20 |                               |

| Index No     | chemical name  | Notes related to substances | EC No                          | CAS No                       | Classification                            | Labelling  | Concentration Limits  | Notes related to preparations |
|--------------|--|-----------------------------|--------------------------------|------------------------------|---|--|---|-------------------------------|
| 606-037-00-4 | triadimefon (ISO)<br>1-(4-chlorophenoxy)-3,3-dimethyl-1-(1,2,4-triazol-1-yl)butanone   |                             | 256-103-8                      | 43121-43-3                   | Xn; R22<br>R43<br>N; R51-53               | Xn; N<br>R: 22-43-51/53<br>S: (2-)24-37-61                                 |   |                               |
| 606-048-00-4 | 2'-anilino-3'-methyl-6'-dipentylaminospiro(isobenzofuran-1(1H),9'-xanthen)-3-one   |                             | 406-480-1                      | —                            | R53                                       | R: 53<br>S: 61   |   |                               |
| 607-004-00-7 | trichloroacetic acid   |                             | 200-927-2                      | 76-03-9                      | C; R35<br>N; R50-53                       | C; N<br>R: 35-50/53<br>S: (1/2-)26-36/37/39-45-60-61                       | C ≥ 25 %: C, N; R35-50/53<br>10 % ≤ C < 25 %: C, N; R35-51/53<br>5 % ≤ C < 10 %: C, N; R34-51/53<br>2,5 % ≤ C < 5 %: Xi, N; R36/37/38-51/53<br>1 % ≤ C < 2,5 %: Xi; R36/37/38-52/53<br>0,25 % ≤ C < 1 %: R52/53                                       |                               |
| 607-019-00-9 | methyl chloroformate   |                             | 201-187-3                      | 79-22-1                      | F; R11<br>T+; R26<br>Xn; R21/22<br>C; R34 | F; T+<br>R: 11-21/22-26-34<br>S: (1/2-)26-14-28-36/37-39-36/37/39-45-46-63 |   |                               |
| 607-049-00-2 | mecoprop (ISO) [1] and its salts<br>2-(4-chloro- <i>o</i> -tolylxy) propionic acid<br>( <i>RS</i> )-2-(4-chloro- <i>o</i> -tolylxy)propionic acid<br>[1]<br>2-(4-chloro-2-methylphenoxy)-propionic acid<br>[2] |                             | 230-386-8 [1]<br>202-264-4 [2] | 7085-19-0 [1]<br>93-65-2 [2] | Xn; R22<br>Xi; R38-41<br>N; R50-53        | Xn; N<br>R: 22-38-41-50/53<br>S: (2-)13-26-37/39-60-61                     | C ≥ 25 %: Xn, N; R22-38-41-50-53<br>20 % ≤ C < 25 %: Xi, N; R38-41-50-53<br>10 % ≤ C < 20 %: Xi, N; R41-50-53<br>5 % ≤ C < 10 %: Xi, N; R36-50-53<br>0,25 % ≤ C < 5 %: N; R50-53<br>0,025 % ≤ C < 0,25 %: N; R51-53<br>0,0025 % ≤ C < 0,025 %: R52-53 |                               |
| 607-053-00-4 | MCPB (ISO)<br>4-(4-chloro- <i>o</i> -tolylxy) butyric acid   |                             | 202-365-3                      | 94-81-5                      | N; R50-53                                 | N<br>R: 50/53<br>S: 60-61  |   |                               |
| 607-061-00-8 | acrylic acid<br>prop-2-enoic acid  | D                           | 201-177-9                      | 79-10-7                      | R10<br>Xn; R20/21/22<br>C; R35<br>N; R50  | C; N<br>R: 10-20/21/22-35-50<br>S: (1/2-)26-36/37/39-45-61                 | C ≥ 25 %: C, N; R20/21/22-35-50<br>10 % ≤ C < 25 %: C; R35<br>5 % ≤ C < 10 %: C; R34<br>1 ... % ≤ C < 5 %: Xi; R36/37/38  |                               |



| Index No     | chemical name              | Notes related to substances | EC No     | CAS No    | Classification                                    | Labelling   | Concentration Limits  | Notes related to preparations |
|--------------|----------------------------|-----------------------------|-----------|-----------|---|---|---|-------------------------------|
| 607-064-00-4 | benzyl chloroformate       |                             | 207-925-0 | 501-53-1  | C; R34<br>N; R50-53                               | C; N<br>R: 34-50/53<br>S: (1/2-)26-45-60-61                         | C ≥ 25 %: C, N; R34-50/53<br>10 % ≤ C < 25 %: C, N; R34-51/53<br>5 % ≤ C < 10 %: Xi, N; R36/37/38-51/53<br>2,5 % ≤ C < 5 %: N; R51/53<br>0,25 % ≤ C < 2,5 %: R52/53 |                               |
| 607-072-00-8 | 2-hydroxyethyl acrylate    | D                           | 212-454-9 | 818-61-1  | T; R24<br>C; R34<br>R43<br>N; R50                 | T; N<br>R: 24-34-43-50<br>S: (1/2-)26-36/39-45-61                   | C ≥ 25 %: T; R24-34-43-50<br>10 % ≤ C < 25 %: T; R24-34-43<br>5 % ≤ C < 10 %: T; R24-36/38-43<br>2 % ≤ C < 5 %: T; R24-43<br>0,2 % ≤ C < 2 %: Xn; R21-43            |                               |
| 607-086-00-4 | diallyl phthalate          |                             | 205-016-3 | 131-17-9  | Xn; R22<br>N; R50-53                              | Xn; N<br>R: 22-50/53<br>S: (2-)24/25-60-61                          | C ≥ 25 %: Xn, N; R22-50/53<br>2,5 % ≤ C < 25 %: N; R51/53<br>0,25 % ≤ C < 2,5 %: R52/53   |                               |
| 607-091-00-1 | trifluoroacetic acid ... % | B                           | 200-929-3 | 76-05-1   | Xn; R20<br>C; R35<br>R52-53                       | C<br>R: 20-35-52/53<br>S: (1/2-)9-26-27-28-45-61                    | C ≥ 25 %: C; R20-35-52/53<br>10 % ≤ C < 25 %: C; R20-35<br>5 % ≤ C < 10 %: C; R34<br>1 % ≤ C < 5 %: Xi; R36/38  |                               |
| 607-094-00-8 | peracetic acid ... %       |                             | 201-186-8 | 79-21-0   | R10<br>O; R7<br>Xn; R20/21/22<br>C; R35<br>N; R50 | O; C; N<br>R: 7-10-20/21/22-35-50<br>S: (1/2-)3/7-14-36/37/39-45-61 | C ≥ 25 %: C, N; R20/21/22-35-50<br>10 % ≤ C < 25 %: C; R20/21/22-35<br>5 % ≤ C < 10 %: C; R34<br>1 % ≤ C < 5 %: Xi, R36/37/38                                       |                               |
| 607-107-00-7 | 2-ethylhexyl acrylate      | D                           | 203-080-7 | 103-11-7  | Xi; R37/38<br>R43                                 | Xi<br>R: 37/38-43<br>S: (2-)36/37-46                                |   |                               |
| 607-113-00-X | isobutyl methacrylate      | D                           | 202-613-0 | 97-86-9   | R10<br>Xi; R36/37/38<br>R43<br>N; R50             | Xi; N<br>R: 10-36/37/38-43-50<br>S: (2-)24-37-61                    | C ≥ 25 %: Xi, N; R36/37/38-43-50<br>20 % ≤ C < 25 %: Xi; R36/37/38-43<br>1 % ≤ C < 20 %: Xi; R43  |                               |
| 607-116-00-6 | cyclohexyl acrylate        | D                           | 221-319-3 | 3066-71-5 | Xi; R37/38<br>N; R51-53                           | Xi; N<br>R: 37/38-51/53<br>S: (2-)61                                | C ≥ 25 %: Xi, N; R37/38-51/53<br>10 % ≤ C < 25 %: Xi; R37/38-52/53<br>2,5 % ≤ C < 10 %: R52/53  |                               |

| Index No     | chemical name   | Notes related to substances | EC No     | CAS No     | Classification  | Labelling   | Concentration Limits   | Notes related to preparations |
|--------------|---|-----------------------------|-----------|------------|---|---|--|-------------------------------|
| 607-133-00-9 | monoalkyl or monoaryl or monoalkylaryl esters of acrylic acid with the exception of those specified elsewhere in this Annex | A                           | —         | —          | Xi; R36/37/38<br>N; R51-53                                | Xi; N<br>R: 36/37/38-51/53<br>S: (2-)26-28-61                 | C ≥ 25 %: Xi, N; R36/37/38-51/53<br>10 % ≤ C < 25 %: Xi; R36/37/38-52/53<br>2,5 % ≤ C < 10 %: R52/53   |                               |
| 607-151-00-7 | propargite (ISO)<br>2-(4- <i>tert</i> -butylphenoxy) cyclohexyl prop-2-ynyl sulphite  |                             | 219-006-1 | 2312-35-8  | Carc.Cat.3; R40<br>T; R23<br>Xi; R38-41<br>N; R50-53      | T; N<br>R: 23-38-40-41-50/53<br>S: (1/2-)26-36/37/39-45-60-61 | C ≥ 25 %: T, N; R23-38-40-41-50-53<br>20 % ≤ C < 25 %: Xn, N; R20-38-40-41-50-53<br>10 % ≤ C < 20 %: Xn, N; R20-40-41-50-53<br>5 % ≤ C < 10 %: Xn, N; R20-40-36-50-53<br>3 % ≤ C < 5 %: Xn, N; R20-40-50-53<br>2,5 % ≤ C < 3 %: Xn, N; R40-50-53<br>1 % ≤ C < 2,5 %: Xn, N; R40-51-53<br>0,25 % ≤ C < 1 %: N; R51-53<br>0,025 % ≤ C < 0,25 %: R52-53 |                               |
| 607-189-00-4 | trimethylenediaminetetraacetic acid   |                             | 400-400-9 | 1939-36-2  | Xn; R22<br>Xi; R41<br>N; R50-53                           | Xn; N<br>R: 22-41-50/53<br>S: (2-)22-26-39-60-61              |  |                               |
| 607-244-00-2 | isooctyl acrylate   |                             | 249-707-8 | 29590-42-9 | Xi; R36/37/38<br>N; R50-53                                | Xi; N<br>R: 36/37/38-50/53<br>S: (2-)26-28-60-61              | C ≥ 25 %: Xi, N; R36/37/38-50/53<br>10 % ≤ C < 25 %: Xi, N; R36/37/38-51/53<br>2,5 % ≤ C < 10 %: N; R51/53<br>0,25 % ≤ C < 2,5 %: R52/53   |                               |
| 607-245-00-8 | <i>tert</i> -butyl acrylate   | D                           | 216-768-7 | 1663-39-4  | F; R11<br>Xn; R20/21/22<br>Xi; R37/38<br>R43<br>N; R52-53 | F; Xn<br>R: 11-20/21/22-37/38-43-52/53<br>S: (2-)16-25-37-61  | C ≥ 25 %: Xn; R20/21/22-37/38-43-52-53<br>20 % ≤ C < 25 %: Xi; R37/38-43<br>1 % ≤ C < 20 %: Xi; R43  |                               |
| 607-247-00-9 | dodecyl methacrylate  |                             | 205-570-6 | 142-90-5   | Xi; 36/37/38<br>N; R50-53                                 | Xi; N<br>R: 36/37/38-50/53<br>S: (2-)26-28-60-61              | C ≥ 25 %: Xi, N; R36/37/38-50/53<br>10 % ≤ C < 25 %: Xi, N; R36/37/38-51/53<br>2,5 % ≤ C < 10 %: N; R51/53<br>0,25 % ≤ C < 2,50 %: R52/53  |                               |

| Index No     | chemical name  | Notes related to substances | EC No     | CAS No     | Classification   | Labelling   | Concentration Limits  | Notes related to preparations |
|--------------|--|-----------------------------|-----------|------------|--|---|---|-------------------------------|
| 607-249-00-X | (1-methyl-1,2-ethanediy)bis[oxymethyl-2,1-ethanediy] diacrylate                        |                             | 256-032-2 | 42978-66-5 | Xi; R36/37/38<br>R43<br>N; R51-53  | Xi; N<br>R: 36/37/38-43-51/53<br>S: (2-)24-37-61                    | C ≥ 25 %: Xi, N; R36/37/38-43-51/53<br>10 % ≤ C < 25 %: Xi; R36/37/38-43-52/53<br>2,5 % ≤ C < 10 %: Xi; R43-52/53<br>1 % ≤ C < 2,5 %: Xi; R43   |                               |
| 608-003-00-4 | acrylonitrile  | D E                         | 203-466-5 | 107-13-1   | F; R11<br>Carc. Cat. 2; R45<br>T; R23/24/25<br>Xi; R37/38-41<br>R43<br>N; R51-53 | F; T; N<br>R: 45-11-23/24/25-37/38-41-43-51/53<br>S: 9-16-53-45-61  | C ≥ 25 %: T, N; R45-23/24/25-37/38-41-43-51/53<br>20 % ≤ C < 25 %: T; R45-23/24/25-37/38-41-43-52/53<br>10 % ≤ C < 20 %: T; R45-23/24/25-41-43-52/53<br>5 % ≤ C < 10 %: T; R45-23/24/25-36-43-52/53<br>2,5 % ≤ C < 5 %: T; R45-23/24/25-43-52/53<br>1 % ≤ C < 2,5 %: T; R45-23/24/25-43<br>0,2 % ≤ C < 1 %: T; R45-20/21/22<br>0,1 % ≤ C < 0,2 %: T; R45    |                               |
| 608-006-00-0 | bromoxynil (ISO) and its salts<br>3,5-dibromo-4-hydroxybenzotrile<br>bromoxynil phenol |                             | 216-882-7 | 1689-84-5  | Repr. Cat. 3; R63<br>T+; R26<br>T; R25<br>R43<br>N; R50-53                       | T+; N<br>R: 25-26-43-63-50/53<br>S: (1/2-)27/28-36/37-45-63-60-61   | C ≥ 25 %: T+, N; R25-26-43-63-50-53<br>7 % ≤ C < 25 %: T+, N; R22-26-43-63-50-53<br>5 % ≤ C < 7 %: T, N; R22-23-43-63-50-53<br>3 % ≤ C < 5 %: T, N; R22-23-43-50-53<br>2,5 % ≤ C < 3 %: T, N; R23-43-50-53<br>1 % ≤ C < 2,5 %: T, N; R23-43-51-53<br>0,25 % ≤ C < 1 %: Xn, N; R20-51-53<br>0,1 % ≤ C < 0,25 %: Xn; R20-52-53<br>0,025 % ≤ C < 0,1 %: R52-53 |                               |
| 608-007-00-6 | ioxynil (ISO) and its salts<br>4-hydroxy-3,5-diiodobenzotrile                          |                             | 216-881-1 | 1689-83-4  | Repr. Cat. 3; R63<br>T; R23/25<br>Xn; R21-48/22<br>Xi; R36<br>N; R50-53          | T; N<br>R: 21-23/25-36-48/22-63-50/53<br>S: (1/2-)36/37-45-60-61-63 | C ≥ 25 %: T, N; R21-23/25-36-48/22-63-50-53<br>20 % ≤ C < 25 %: Xn, N; R20/22-36-48/22-63-50-53<br>10 % ≤ C < 20 %: Xn, N; R20/22-48/22-63-50-53<br>5 % ≤ C < 10 %: Xn, N; R20/22-63-50-53<br>3 % ≤ C < 5 %: Xn, N; R20/22-50-53<br>2,5 % ≤ C < 3 %: N; R50-53<br>0,25 % ≤ C < 2,5 %: N; R51-53<br>0,025 % ≤ C < 0,25 %: R52-53                             |                               |

| Index No     | chemical name   | Notes related to substances | EC No     | CAS No     | Classification   | Labelling   | Concentration Limits   | Notes related to preparations |
|--------------|---|-----------------------------|-----------|------------|--|---|--|-------------------------------|
| 608-010-00-2 | methacrylonitrile<br>2-methyl-2-propene nitrile                           | D                           | 204-817-5 | 126-98-7   | F; R11<br>T; R23/24/25<br>R43  | F; T<br>R: 11-23/24/25-43<br>S: (1/2-)9-16-18-29-45                     | C ≥ 1 %: T; R23/24/25-43<br>0,2 % ≤ C < 1 %: Xn; R20/21/22-43  |                               |
| 608-014-00-4 | chlorothalonil (ISO)<br>tetrachloroisophthalonitrile                      |                             | 217-588-1 | 1897-45-6  | Carc. Cat. 3; R40<br>T+; R26<br>Xi; R41<br>Xi; R37<br>R43<br>N; R50-53 | T+; N<br>R: 26-37-40-41-43-50/<br>53<br>S: (2-)28-36/37/39-45-<br>60-61 | C ≥ 20 %: T+, N; R26-37-40-41-43-50-53<br>10 % ≤ C < 20 %: T+, N; R26-40-41-43-<br>50-53<br>7 % ≤ C < 10 %: T+, N; R26-40-36-43-<br>50-53<br>5 % ≤ C < 7 %: T, N; R23-40-36-43-50-<br>53<br>2,5 % ≤ C < 5 %: T, N; R23-40-43-50-53<br>1 % ≤ C < 2,5 %: T, N; R23-40-43-51-53<br>0,25 % ≤ C < 1 %: Xn, N; R20-51-53<br>0,1 % ≤ C < 0,25 %: Xn; R20-52-53<br>0,025 % ≤ C < 0,1 %: R52-53 |                               |
| 608-017-00-0 | bromoxynil octanoate (ISO)<br>2,6-dibromo-4-cyanophenyl<br>octanoate      |                             | 216-885-3 | 1689-99-2  | Repr. Cat. 3; R63<br>T; R23<br>Xn; R22<br>R43<br>N; R50-53             | T; N<br>R: 22-23-43-63-50/53<br>S: (1/2-)36/37-45-63-60-<br>61          | C ≥ 25 %: T, N; R22-23-43-63-50-53<br>5 % ≤ C < 25 %: Xn, N; R20-43-63-50-53<br>3 % ≤ C < 5 %: Xn, N; R20-43-50-53<br>2,5 % ≤ C < 3 %: Xi, N; R43-50-53<br>1 % ≤ C < 2,5 %: Xi, N; R43-51-53<br>0,25 % ≤ C < 1 %: N; R51-53<br>0,025 % ≤ C < 0,25 %: R52-53  |                               |
| 608-018-00-6 | ioxynil octanoate (ISO)<br>4-cyano-2,6-diiodophenyl<br>octanoate          |                             | 223-375-4 | 3861-47-0  | Repr. Cat. 3; R63<br>T; R25<br>Xi; R36<br>R43<br>N; R50-53             | T; N<br>R: 25-36-43-63-50/53<br>S: (1/2-)26-36/37-45-60-<br>61          | C ≥ 25 %: T, N; R25-36-43-63-50-53<br>20 % ≤ C < 25 %: Xn, N; R22-36-43-63-<br>50-53<br>5 % ≤ C < 20 %: Xn, N; R22-43-63-50-53<br>3 % ≤ C < 5 %: Xn, N; R22-43-50-53<br>2,5 % ≤ C < 3 %: N; R43-50-53<br>1 % ≤ C < 2,5 %: N; R43-51-53<br>0,25 % ≤ C < 1 %: N; R51-53<br>0,025 % ≤ C < 0,25 %: R52-53  |                               |
| 608-021-00-2 | 3-(2-(diaminomethyleneamino)<br>thiazol-4-ylmethylthio)propioni-<br>trile |                             | 403-710-2 | 76823-93-3 | Xn; R22<br>R43   | Xn<br>R: 22-43<br>S: (2-)22-24-37                                       |  |                               |

| Index No     | chemical name   | Notes related to substances | EC No                          | CAS No                         | Classification   | Labelling  | Concentration Limits | Notes related to preparations |
|--------------|---|-----------------------------|--------------------------------|--------------------------------|--|--|----------------------|-------------------------------|
| 609-007-00-9 | 2,4-dinitrotoluene<br>dinitrotoluene, technical grade<br>[1]<br>dinitrotoluene<br>[2] | E                           | 204-450-0 [1]<br>246-836-1 [2] | 121-14-2 [1]<br>25321-14-6 [2] | Carc. Cat. 2; R45<br>Muta. Cat. 3; R68<br>Repr. Cat. 3; R62<br>T; R23/24/25<br>Xn; R48/22<br>N; R51-53 | T; N<br>R: 45-23/24/25-48/22-62-68-51/53<br>S: 53-45-61    |                      |                               |
| 609-023-00-6 | dinocap (ISO)   | E                           | 254-408-0                      | 39300-45-3                     | Repr. Cat. 2; R61<br>Xn; R20-48/22<br>Xi; R38<br>R43<br>N; R50-53                                      | T; N<br>R: 61-20-22-38-43-48/22-50/53<br>S: 53-45-60-61    |                      |                               |
| 609-043-00-5 | quintozene (ISO)<br>pentachloronitrobenzene   |                             | 201-435-0                      | 82-68-8                        | R43<br>N; R50-53   | Xi; N<br>R: 43-50/53<br>S: (2-)13-24-37-60-61              |                      |                               |
| 609-049-00-8 | 2,6-dinitrotoluene  | E                           | 210-106-0                      | 606-20-2                       | Carc. Cat. 2; R45<br>Muta. Cat. 3; R68<br>Repr. Cat. 3; R62<br>T; R23/24/25<br>Xn; R48/22<br>R52-53    | T<br>R: 45-23/24/25-48/22-62-68-52/53<br>S: 53-45-61       |                      |                               |
| 609-050-00-3 | 2,3-dinitrotoluene  | E                           | 210-013-5                      | 602-01-7                       | Carc. Cat. 2; R45<br>Muta. Cat. 3; R68<br>Repr. Cat. 3; R62<br>T; R23/24/25<br>Xn; R48/22<br>N; R50-53 | T; N<br>R: 45-23/24/25-48/22-62-68-50/53<br>S: 53-45-60-61 |                      |                               |
| 609-051-00-9 | 3,4-dinitrotoluene  | E                           | 210-222-1                      | 610-39-9                       | Carc. Cat. 2; R45<br>Muta. Cat. 3; R68<br>Repr. Cat. 3; R62<br>T; R23/24/25<br>Xn; R48/22<br>N; R51-53 | T; N<br>R: 45-23/24/25-48/22-62-68-51/53<br>S: 53-45-61    |                      |                               |

| Index No     | chemical name              | Notes related to substances | EC No     | CAS No     | Classification   | Labelling  | Concentration Limits  | Notes related to preparations |
|--------------|----------------------------|-----------------------------|-----------|------------|--|--|---|-------------------------------|
| 609-052-00-4 | 3,5-dinitrotoluene         | E                           | 210-566-2 | 618-85-9   | Carc. Cat. 2; R45<br>Muta. Cat. 3; R68<br>Repr. Cat. 3; R62<br>T; R23/24/25<br>Xn; R48/22<br>R52-53    | T<br>R: 45-23/24/25-48/22-62-68-52/53<br>S: 53-45-61                           |   |                               |
| 609-055-00-0 | 2,5-dinitrotoluene         | E                           | 210-581-4 | 619-15-8   | Carc. Cat. 2; R45<br>Muta. Cat. 3; R68<br>Repr. Cat. 3; R62<br>T; R23/24/25<br>Xn; R48/22<br>N; R51-53 | T; N<br>R: 45-23/24/25-48/22-62-68-51/53<br>S: 53-45-61                        |   |                               |
| 609-056-00-6 | 2,2-dibromo-2-nitroethanol |                             | 412-380-9 | 69094-18-4 | E; R2<br>Carc. Cat. 3; R40<br>Xn; R22-48/22<br>C; R35<br>R43<br>N; R50-53                              | E; C; N<br>R: 2-22-35-40-43-48/22-50/53<br>S: (1/2-)23-26-35-36/37/39-45-60-61 | C ≥ 25 %: C, N; R22-35-40-43-48/22-50/53<br>10 % ≤ C < 25 %: C, N; R22-35-40-43-48/22-51/53<br>5 % ≤ C < 10 %: C, N; R34-40-43-51/53<br>2,5 % ≤ C < 5 %: Xn, N; R36/37/38-40-43-51/53<br>1 % ≤ C < 2,5 %: Xn; R36/37/38-40-43-52/53<br>0,25 % ≤ C < 1 %: R52/53 |                               |
| 610-005-00-5 | 1-chloro-4-nitrobenzene    |                             | 202-809-6 | 100-00-5   | Carc. Cat. 3; R40<br>Mut. Cat. 3; R68<br>T; R23/24/25<br>Xn; R48/20/21/22<br>N; R51-53                 | T; N<br>R: 23/24/25-40-48/20/21/22-68-51/53<br>S: (1/2-)28-36/37-45-61         |   |                               |
| 611-001-00-6 | azobenzene                 | E                           | 203-102-5 | 103-33-3   | Carc. Cat. 2; R45<br>Muta. Cat. 3; R68<br>Xn; R20/22-48/22<br>N; R50-53                                | T; N<br>R: 45-20/22-48/22-68-50/53<br>S: 53-45-60-61                           |   |                               |

| Index No     | chemical name   | Notes related to substances | EC No     | CAS No      | Classification   | Labelling   | Concentration Limits  | Notes related to preparations |
|--------------|---|-----------------------------|-----------|-------------|--|---|---|-------------------------------|
| 611-060-00-8 | A mixture of: sodium 5-[8-[4-[4-[4-[7-(3,5-dicarboxylatophenylazo)-8-hydroxy-3,6-disulfonatonaphthalen-1-ylamino]-6-hydroxy-1,3,5-triazin-2-yl]-2,5-dimethylpiperazin-1-yl]-6-hydroxy-1,3,5-triazin-2-ylamino]-1-hydroxy-3,6-disulfonatonaphthalen-2-ylazo]-isophthalate; ammonium 5-[8-[4-[4-[4-[7-(3,5-dicarboxylatophenylazo)-8-hydroxy-3,6-disulfonatonaphthalen-1-ylamino]-6-hydroxy-1,3,5-triazin-2-yl]-2,5-dimethylpiperazin-1-yl]-6-hydroxy-1,3,5-triazin-2-ylamino]-1-hydroxy-3,6-disulfonatonaphthalen-2-ylazo]-isophthalate; 5-[8-[4-[4-[4-[7-(3,5-dicarboxylatophenylazo)-8-hydroxy-3,6-disulfonatonaphthalen-1-ylamino]-6-hydroxy-1,3,5-triazin-2-yl]-2,5-dimethylpiperazin-1-yl]-6-hydroxy-1,3,5-triazin-2-ylamino]-1-hydroxy-3,6-disulfonatonaphthalen-1-ylamino]-6-hydroxy-1,3,5-triazin-2-yl]-2,5-dimethylpiperazin-1-yl]-6-hydroxy-1,3,5-triazin-2-ylamino]-1-hydroxy-3,6-disulfonatonaphthalen-2-ylazo]-isophthalic acid |                             | 413-180-4 | —           | Xi; R41  | Xi<br>R: 41<br>S: (2-)22-26-39  |   |                               |
| 611-063-00-4 | trisodium [4'-(8-acetylamino-3,6-disulfonato-2-naphthylazo)-4''-(6-benzoylamino-3-sulfonato-2-naphthylazo)-biphenyl-1,3',3'',1'''-tetraolato-O,O',O'',O''']copper(II)   |                             | 413-590-3 | 164058-22-4 | Carc. Cat. 2; R45  | T<br>R: 45<br>S: 53-45  |   |                               |
| 612-008-00-7 | aniline   |                             | 200-539-3 | 62-53-3     | Carc. Cat. 3; R40<br>Muta.Cat.3; R68<br>T; R23/24/25-48/23/24/25<br>Xi; R41<br>R43<br>N; R50 | T; N<br>R: 23/24/25-40-41-43-48/23/24/25-68-50<br>S: (1/2-)26-27-36/37/39-45-46-61-63 | C ≥ 25 %: T, N; R23/24/25-40-41-43-48/23/24/25-50-68<br>10 % ≤ C < 25 %: T; R20/21/22-40-41-43-48/23/24/25-68<br>1 % ≤ C < 10 %: T; R20/21/22-40-43-48/23/24/25-68<br>0,2 % ≤ C < 1 %: Xn; R48/20/21/22 |                               |

| Index No     | chemical name  | Notes related to substances | EC No  | CAS No  | Classification  | Labelling  | Concentration Limits  | Notes related to preparations |
|--------------|--|-----------------------------|--|---|---|--|---|-------------------------------|
| 612-009-00-2 | salts of aniline   | A                           | —  | —   | Carc. Cat. 3; R40<br>Muta. Cat. 3; R68<br>T; R23/24/25<br>Xi; R41<br>R43<br>N; R50                | T; N<br>R: 23/24/25-40-41-43-48/23/24/25-68-50<br>S: (1/2-)26-27-36/37/39-45-61-63 | C ≥ 25 %: T, N; R23/24/25-40-41-43-48/23/24/25-50-68<br>10 % ≤ C < 25 %: T; R20/21/22-40-41-43-48/23/24/25-68<br>1 % ≤ C < 10 %: T; R20/21/22-40-43-48/23/24/25-68<br>0,2 % ≤ C < 1 %: Xn; R48/20/21/22 |                               |
| 612-010-00-8 | chloroanilines (with exception of those specified elsewhere in this Annex)   | C                           | —  | —   | T; R23/24/25<br>R33<br>N; R50-53  | T; N<br>R: 23/24/25-33-50/53<br>S: (1/2-)28-36/37-45-60-61                         |   |                               |
| 612-022-00-3 | 2-naphthylamine  | E                           | 202-080-4  | 91-59-8   | Carc. Cat. 1; R45<br>Xn; R22<br>N; R51-53   | T; N<br>R: 45-22-51/53<br>S: 53-45-61  | C ≥ 25 %: T, N; R45-22-51/53<br>2,5 % ≤ C < 25 %: T; R45-52/53<br>0,01 % ≤ C < 2,5 %: T; R45  |                               |
| 612-023-00-9 | phenylhydrazine [1]<br>phenylhydrazinium chloride [2]<br>phenylhydrazine hydrochloride [3]<br>phenylhydrazinium sulphate (2:1) [4] | E                           | 202-873-5 [1]<br>200-444-7 [2]<br>248-259-0 [3]<br>257-622-2 [4] | 100-63-0 [1]<br>59-88-1 [2]<br>27140-08-5 [3]<br>52033-74-6 [4] | Carc. Cat. 2; R45<br>Muta. Cat. 3; R68<br>T; R23/24/25-48/23/24/25<br>Xi; R36/3<br>R438<br>N; R50 | T; N<br>R: 45-23/24/25-36/38-43-48/23/24/25-68-50<br>S: 53-45-61                   |   |                               |
| 612-025-00-X | nitrotoluidines, with the exception of those specified elsewhere in this Annex   | C                           | —  | —   | T; R23/24/25<br>R33<br>N; R51-53  | T; N<br>R: 23/24/25-33-51/53<br>S: (1/2-)28-36/37-45-61                            |   |                               |
| 612-035-00-4 | 2-methoxyaniline<br>o-anisidine  | E                           | 201-963-1  | 90-04-0   | Carc. Cat. 2; R45<br>Muta. Cat. 3; R68<br>T; R23/24/25  | T<br>R: 45-23/24/25-68<br>S: 53-45   |   |                               |
| 612-042-00-2 | benzidine<br>1,1'-biphenyl-4,4'-diamine<br>4,4'-diaminobiphenyl<br>biphenyl-4,4'-ylenediamine                                      | E                           | 202-199-1  | 92-87-5   | Carc. Cat. 1; R45<br>Xn; R22<br>N; R50-53   | T; N<br>R: 45-22-50/53<br>S: 53-45-60-61   | C ≥ 25 %: T, N; R45-22-50/53<br>2,5 % ≤ C < 25 %: T, N; R45-51/53<br>0,01 % ≤ C < 2,5 %: T; R45   |                               |



| Index No     | chemical name   | Notes related to substances | EC No   | CAS No                                      | Classification  | Labelling  | Concentration Limits   | Notes related to preparations |
|--------------|---|-----------------------------|---|---|---|--|--|-------------------------------|
| 612-051-00-1 | 4,4'-diaminodiphenylmethane<br>4,4'-methylenedianiline  | E                           | 202-974-4                                       | 101-77-9                                    | Carc. Cat. 2; R45<br>Muta. Cat. 3; R68<br>T; R39/23/24/25<br>Xn; R48/20/21/22<br>R43<br>N; R51-53 | T; N<br>R: 45-39/23/24/25-43-48/20/21/22-68-51/53<br>S: 53-45-61 |  |                               |
| 612-054-00-8 | N,N-diethylaniline  |                             | 202-088-8                                       | 91-66-7                                     | T; R23/24/25<br>R33<br>N; R51-53  | T; N<br>R: 23/24/25-33-51/53<br>S: (1/2-)28-37-45-61             | C ≥ 25 %: T, N; R23/24/25-33-51/53<br>5 % ≤ C < 25 %: T; R23/24/25-33-52/53<br>2,5 % ≤ C < 5 %: Xn; R20/21/22-33-52/53<br>1 % ≤ C < 2,5 %: Xn; R20/21/22-33  |                               |
| 612-056-00-9 | N,N-dimethyl- <i>p</i> -toluidine [1]<br>N,N-dimethyl- <i>m</i> -toluidine [2]<br>N,N-dimethyl- <i>o</i> -toluidine [3] | C                           | 202-805-4 [1]<br>204-495-6 [2]<br>210-199-8 [3] | 99-97-8 [1]<br>121-72-2 [2]<br>609-72-3 [3] | T; R23/24/25<br>R33<br>R52-53   | T<br>R: 23/24/25-33-52/53<br>S: (1/2-)28-36/37-45-61             | C ≥ 25 %: T; R23/24/25-33-52-53<br>5 % ≤ C < 25 %: T; R23/24/25-33<br>1 % ≤ C < 5 %: Xn; R20/21/22-33  |                               |
| 612-059-00-5 | 3,6-diazaoctanethylenediamin<br>triethylenetetramine  |                             | 203-950-6                                       | 112-24-3                                    | Xn; R21<br>C; R34<br>R43<br>R52-53  | C<br>R: 21-34-43-52/53<br>S: (1/2-)26-36/37/39-45-61             | C ≥ 25 %: C; R21-34-43-52/53<br>10 % ≤ C < 25 %: C; R34-43<br>5 % ≤ C < 10 %: Xi; R36/38-43<br>1 % ≤ C < 5 %: Xi; R43  |                               |
| 612-060-00-0 | 3,6,9-triazaundecamethylenedia-<br>mine<br>tetraethylenepentamine   |                             | 203-986-2                                       | 112-57-2                                    | Xn; R21/22<br>C; R34<br>R43<br>N; R51-53  | C; N<br>R: 21/22-34-43-51/53<br>S: (1/2-)26-36/37/39-45-61       | C ≥ 25 %: C, N; R21/22-34-43-51/53<br>10 % ≤ C < 25 %: C; R34-43-52/53<br>5 % ≤ C < 10 %: Xi; R36/38-43-52/53<br>2,5 % ≤ C < 5 %: Xi; R43-52/53<br>1 % ≤ C < 2,5 %: Xi; R43                                      |                               |
| 612-064-00-2 | 3,6,9,12-tetra-azatetradeca-<br>methylenediamine<br>pentathylenhexamine   |                             | 223-775-9                                       | 4067-16-7                                   | C; R34<br>R43<br>N; R50-53  | C; N<br>R: 34-43-50/53<br>S: (1/2-)26-36/37/39-45-60-61          | C ≥ 25 %: C, N; R34-43-50/53<br>10 % ≤ C < 25 %: C, N; R34-43-51/53<br>5 % ≤ C < 10 %: Xi, N; R36/38-43-51/53<br>2,5 % ≤ C < 5 %: Xi, N; R43-51/53<br>1 % ≤ C < 2,5 %: Xi; R43-52/53<br>0,25 % ≤ C < 1 %: R52/53 |                               |
| 612-065-00-8 | polyethylenepolyamines with the<br>exception of those specified<br>elsewhere in this Annex                              |                             | —   | —   | Xn; R21/22<br>C; R34<br>R43<br>N; R50-53  | C; N<br>R: 21/22-34-43-50/53<br>S: (1/2-)26-36/37/39-45-60-61    | C ≥ 25 %: C, N; R21/22-34-43-50/53<br>10 % ≤ C < 25 %: C, N; R34-43-51/53<br>5 % ≤ C < 10 %: Xi, N; R36/38-43-51/53<br>1 % ≤ C < 2,5 %: Xi; R43-52/53<br>0,25 % ≤ C < 1 %: R52/53                                |                               |

| Index No     | chemical name  | Notes related to substances | EC No     | CAS No     | Classification  | Labelling  | Concentration Limits  | Notes related to preparations |
|--------------|--|-----------------------------|-----------|------------|---|--|---|-------------------------------|
| 612-066-00-3 | dicyclohexylamine  |                             | 202-980-7 | 101-83-7   | Xn; R22<br>C; R34<br>N; R50-53                            | C; N<br>R: 22-34-50/53<br>S: (1/2-)26-36/37/39-45-60-61                          | C ≥ 25 %: C, N; R22-34-50/53<br>10 % ≤ C < 25 %: C, N; R34-51/53<br>2,5 % ≤ C < 10 %: Xi, N; R36/38-51/53<br>2 % ≤ C < 2,5 %: Xi; R36/38-52/53<br>0,25 % ≤ C < 2 %: R52/53  |                               |
| 612-067-00-9 | 3-aminomethyl-3,5,5-trimethyl-cyclohexylamine                        |                             | 220-666-8 | 2855-13-2  | Xn; R21/22<br>C; R34<br>R43<br>R52-53                     | C<br>R: 21/22-34-43-52/53<br>S: (1/2-)26-36/37/39-45-61                          | C ≥ 25 %: C; R21/22-34-43-52/53<br>10 % ≤ C < 25 %: C; R34-43<br>5 % ≤ C < 10 %: Xi; R36/38-43<br>1 % ≤ C < 5 %: Xi; R43  |                               |
| 612-077-00-3 | dimethylnitrosoamine<br>N-nitrosodimethylamine                       | E                           | 200-549-8 | 62-75-9    | Carc. Cat. 2; R45<br>T+; R26<br>T; R25-48/25<br>N; R51-53 | T+; N<br>R: 45-25-26-48/25-51/53<br>S: 53-45-61                                  | C ≥ 25 %: T+, N; R45-25-26-48/25-51/53<br>10 % ≤ C < 25 %: T+; R45-22-26-48/25-52/53<br>7 % ≤ C < 10 %: T+; R45-22-26-48/22-52/53<br>3 % ≤ C < 7 %: T; R45-22-23-48/22-52/53<br>2,5 % ≤ C < 3 %: T; R45-23-48/22-52/53<br>1 % ≤ C < 2,5 %: T; R45-23-48/22<br>0,1 % ≤ C < 1 %: T; R45-20<br>0,001 % ≤ C < 0,1 %: T; R45 |                               |
| 612-086-00-2 | amitraz (ISO)<br>N,N-bis(2,4-xylyliminomethyl)<br>methylamine        |                             | 251-375-4 | 33089-61-1 | Xn; R22-48/22<br>R43<br>N; R50-53                         | Xn; N<br>R: 22-43-48/22-50/53<br>S: (2-)22-60-24-61-36/37                        | C ≥ 25 %: Xn, N; R22-43-48/22-50-53<br>10 % ≤ C < 25 %: Xn, N; R43-48/22-50-53<br>2,5 % ≤ C < 10 %: N; R43-50-53<br>1 % ≤ C < 2,5 %: N; R43-51-53<br>0,25 % ≤ C < 1 %: N; R51-53<br>0,025 % ≤ C < 0,25 %: R52-53  |                               |
| 612-087-00-8 | guazatine  |                             | 236-855-3 | 13516-27-3 | T+; R26<br>Xn; R21/22<br>Xi; R37/38-41<br>N; R50-53       | T+; N<br>R: 21/22-26-37/38-41-50/53<br>S: (1/2-)26-28-36/37/39-38-45-46-60-61-63 |   |                               |
| 612-094-00-6 | 4-(2-chloro-4-trifluoromethyl)-phenoxy-2-fluoroaniline hydrochloride |                             | 402-190-4 | —          | T; R48/25<br>Xn; R22-48/20<br>Xi; R41<br>R43<br>N; R50-53 | T; N<br>R: 22-41-43-48/20-48/25-50/53<br>S: (1/2-)26-36/37/39-45-60-61           |   |                               |

| Index No     | chemical name  | Notes related to substances | EC No   | CAS No  | Classification   | Labelling  | Concentration Limits   | Notes related to preparations |
|--------------|--|-----------------------------|---|---|--|--|--|-------------------------------|
| 612-121-00-1 | amines, polyethylenepoly-HEPA  |                             | 268-626-9                                       | 68131-73-7                                    | Xn; R21/22<br>C; R34<br>R43<br>N; R50-53                                 | C; N<br>R: 21/22-34-43-50/53<br>S: (1/2-)26-36/37/39-45-60-61  | C ≥ 25 %: C, N; R21/22-34-43-50/53<br>10 % ≤ C < 25 %: C, N; R34-43-51/53<br>5 % ≤ C < 10 %: Xi, N; R36/38-43-51/53<br>2,5 % ≤ C < 5 %: Xi, N; R43-51/53<br>1 % ≤ C < 2,5 %: Xi; R43-52/53<br>0,25 % ≤ C < 1 %: R52/53   |                               |
| 612-136-00-3 | N-isopropyl-N'-phenyl-p-phenylenediamine   |                             | 202-969-7                                       | 101-72-4                                      | Xn; R22<br>R43<br>N; R50-53  | Xn; N<br>R: 22-43-50/53<br>S: (2-)24-37-60-61                  | C ≥ 25 %: Xn, N; R22-43-50/53<br>2,5 % ≤ C < 25 %: Xi, N; R43-51/53<br>0,25 % ≤ C < 2,5 %: Xi; R43-52/53<br>0,1 % ≤ C < 0,25 %: Xi; R43  |                               |
| 612-151-00-5 | diaminotoluene, technical product - mixture of [2] and [3] methyl-phenylenediamine [1] 4-methyl-m-phenylene diamine [2] 2-methyl-m-phenylene diamine [3] | E                           | 246-910-3 [1]<br>202-453-1 [2]<br>212-513-9 [3] | 25376-45-8 [1]<br>95-80-7 [2]<br>823-40-5 [3] | Carc. Cat. 2; R45<br>T; R25<br>Xn; R20/21<br>Xi; R36<br>R43<br>N; R51-53 | T; N<br>R: 45-20/21-25-36-43-51/53<br>S: 53-45-61              |  |                               |
| 613-009-00-5 | 2,4,6-trichloro-1,3,5-triazine cyanuric chloride   |                             | 203-614-9                                       | 108-77-0                                      | T+; R26<br>Xn; R22<br>C; R34<br>R43<br>R14                               | T+; C<br>R: 14-22-26-34-43<br>S: (1/2-)26-28-36/37/39-45-46-63 | C ≥ 25 %: T+; R22-26-34-43<br>10 % ≤ C < 25 %: T+; R26-34-43<br>7 % ≤ C < 10 %: T+; R26-36/37/38-43<br>5 % ≤ C < 7 %: T; R23-36/37/38-43<br>1 % ≤ C < 5 %: T; R23-43<br>0,1 % ≤ C < 1 %: Xn; R20   |                               |
| 613-011-00-6 | amitrole (ISO) 1,2,4-triazol-3-ylamine   |                             | 200-521-5                                       | 61-82-5                                       | Repr.Cat.3; R63<br>Xn; R48/22<br>N; R51-53                               | Xn; N<br>R: 48/22-63-51/53<br>S: (2-)13-36/37-61               |  |                               |
| 613-033-00-6 | 2-methylaziridine propyleneimine   | E                           | 200-878-7                                       | 75-55-8                                       | F; R11<br>Carc. Cat. 2; R45<br>T+; R26/27/28<br>Xi; R41<br>N; R51-53     | F; T+; N<br>R: 45-11-26/27/28-41-51/53<br>S: 53-45-61          | C ≥ 25 %: T+, N; R45-26/27/28-41-51/53<br>10 % ≤ C < 25 %: T+; R45-26/27/28-41-52/53<br>7 % ≤ C < 10 %: T+; R45-26/27/28-36-52/53<br>5 % ≤ C < 7 %: T; R45-23/24/25-36-52/53<br>2,5 % ≤ C < 5 %: T; R45-23/24/25-52/53<br>1 % ≤ C < 2,5 %: T; R45-23/24/25<br>0,1 % ≤ C < 1 %: T; R45-20/21/22<br>0,01 % ≤ C < 0,1 %: T; R45 |                               |
| 613-040-00-4 | azaconazole (ISO) 1-[[2-(2,4-dichlorophenyl)-1,3-dioxolan-2-yl]methyl]-1H-1,2,4-triazole   |                             | 262-102-3                                       | 60207-31-0                                    | Xn; R22  | Xn<br>R: 22<br>S: (2-)46                                       |  |                               |

| Index No     | chemical name  | Notes related to substances | EC No                          | CAS No                           | Classification   | Labelling  | Concentration Limits  | Notes related to preparations |
|--------------|--|-----------------------------|--------------------------------|----------------------------------|--|--|---|-------------------------------|
| 613-043-00-0 | imazalil sulphate (ISO) powder<br>1-[2-(allyloxy)ethyl-2-(2,4-dichlorophenyl)]-1H-imidazolium hydrogen sulphate [1]<br>(±)-1-[2-(allyloxy)ethyl-2-(2,4-dichlorophenyl)]-1H-imidazolium hydrogen sulphate [2] |                             | 261-351-5 [1]<br>281-291-3 [2] | 58594-72-2 [1]<br>83918-57-4 [2] | Xn; R22<br>R43<br>N; R50-53  | Xn; N<br>R: 22-43-50/53<br>S: (2-)24/25-37-46-60-61            |   |                               |
| 613-048-00-8 | carbendazim (ISO)<br>methyl benzimidazol-2-ylcarbamate   |                             | 234-232-0                      | 10605-21-7                       | Muta. Cat. 2; R46<br>Repr.Cat.2; R60-61<br>N; R50-53                             | T; N<br>R: 46-60-61-50/53<br>S: 53-45-60-61                    |   |                               |
| 613-049-00-3 | benomyl (ISO)<br>methyl<br>1-(butylcarbamoyl)benzimidazol-2-ylcarbamate  |                             | 241-775-7                      | 17804-35-2                       | Muta. Cat. 2; R46<br>Repr.Cat.2; R60-61<br>Xi; R37/38<br>R43<br>N; R50-53        | T; N<br>R: 46-60-61-37/38-43-50/53<br>S: 53-45-60-61           | C ≥ 20 %: T, N; R46-60-61-37/38-43-50-53<br>2,5 % ≤ C < 20 %: T, N; R46-60-61-43-50-53<br>1 % ≤ C < 2,5 %: T, N; R46-60-61-43-51-53<br>0,5 % ≤ C < 1 %: T, N; R46-60-61-51-53<br>0,25 % ≤ C < 0,5 %: T, N; R46-51-53<br>0,1 % ≤ C < 0,25 %: T; R46-52-53<br>0,025 % ≤ C < 0,1 %: R52-53 |                               |
| 613-051-00-4 | molinate (ISO)<br>S-ethyl<br>1-perhydroazepinecarbothioate<br>S-ethyl perhydroazepine-1-carbothioate   |                             | 218-661-0                      | 2212-67-1                        | Carc.Cat3; R40<br>Repr.Cat3; R62<br>Xn; R20/22<br>Xn; R48/22<br>R43<br>N; R50-53 | T; N<br>R: 20/22-40-43-48/22-63-50/53<br>S: (2-)36/37-46-60-61 | C ≥ 25 %: Xn, N; R20/22-40-43-48/22-62-50-53<br>10 % ≤ C < 25 %: Xn, N; R40-43-48/22-62-50-53<br>5 % ≤ C < 10 %: Xn, N; R40-43-62-50-53<br>1 % ≤ C < 5 %: Xn, N; R40-43-50-53<br>0,25 % ≤ C < 1 %: N; R50-53<br>0,025 % ≤ C < 0,25 %: N; R51-53<br>0,0025 % ≤ C < 0,025 %: R52-53       |                               |
| 613-058-00-2 | permethrin (ISO)<br>m-phenoxybenzyl 3-(2,2-dichlorovinyl)-2,2-dimethylcyclopropanecarboxylate  |                             | 258-067-9                      | 52645-53-1                       | Xn; R20/22<br>R43<br>N; R50-53   | Xn; N<br>R: 20/22-43-50/53<br>S: (2-)13-24-36/37/39-60-61      | C ≥ 25 %: Xn, N; R20/22-43-50-53<br>1 % ≤ C < 25 %: N; R43-50-53<br>0,025 % ≤ C < 1 %: N; R50-53<br>0,0025 % ≤ C < 0,025 %: N; R51-53<br>0,00025 % ≤ C < 0,0025 %: R52-53   |                               |

| Index No     | chemical name   | Notes related to substances | EC No     | CAS No     | Classification  | Labelling   | Concentration Limits  | Notes related to preparations |
|--------------|---|-----------------------------|-----------|------------|---|---|---|-------------------------------|
| 613-075-00-5 | 1,3-dichloro-5-ethyl-5-methylimidazolidine-2,4-dione  |                             | 401-570-7 | 89415-87-2 | O; R8<br>T; R23<br>C; R34<br>Xn; R22<br>R43<br>N; R50 | O; T; N<br>R: 8-22-23-34-43-50<br>S: (1/2-)8-26-36/37/39-45-61    |   |                               |
| 613-088-00-6 | 1,2-benzisothiazol-3(2H)-one<br>1,2-benzisothiazolin-3-one  |                             | 220-120-9 | 2634-33-5  | Xn; R22<br>Xi; R38-41<br>R43<br>N; R50                | Xn; N<br>R: 22-38-41-43-50<br>S: (2-)24-26-37/39-61               | C ≥ 25 %: Xn, N; R22-38-41-43-50<br>20 % ≤ C < 25 %: Xi; R38-41-43<br>10 % ≤ C < 20 %: Xi; R41-43<br>5 % ≤ C < 10 %: Xi; R36-43<br>0,05 % ≤ C < 5 %: Xi; R43  |                               |
| 613-112-00-5 | 2-octyl-2H-isothiazol-3-one   |                             | 247-761-7 | 26530-20-1 | T; R23/24<br>Xn; R22<br>C; R34<br>R43<br>N; R50-53    | T; N<br>R: 22-23/24-34-43-50/53<br>S: (1/2-)26-36/37/39-45-60-61  | C ≥ 25 %: T, N; R22-23/24-34-43-50/53<br>10 % ≤ C < 25 %: C, N; R20/21-34-43-51/53<br>5 % ≤ C < 10 %: Xn, N; R20/21-36/38-43-51/53<br>3 % ≤ C < 5 %: Xn, N; R20/21-43-51/53<br>2,5 % ≤ C < 3 %: Xi, N; R43-51/53<br>0,25 % ≤ C < 2,5 %: Xi; R43-52/53<br>0,05 % ≤ C < 0,25 %: Xi; R43 |                               |
| 613-124-00-0 | fenpropimorph<br>cis-4-[3-(p-tert-butylphenyl)-2-methylpropyl]-2,6-dimethylmorpholine   |                             | 266-719-9 | 67564-91-4 | Repr. Cat. 3; R63<br>Xn; R22<br>Xi; R38<br>N; R51-53  | Xn; N<br>R: 22-38-63-51/53<br>S: (2-)36/37-46-61                  |   |                               |
| 613-129-00-8 | metamitron<br>4-amino-3-methyl-6-phenyl-1,2,4-triazin-5-one   |                             | 255-349-3 | 41394-05-2 | Xn; R22<br>N; R50                                     | Xn; N<br>R: 22-50<br>S: (2-)61                                    |   |                               |
| 613-167-00-5 | mixture of: 5-chloro-2-methyl-4-isothiazolin-3-one [EC no. 247-500-7]<br>and 2-methyl-2H-isothiazol-3-one [EC no. 220-239-6] (3:1)<br>mixture of: 5-chloro-2-methyl-4-isothiazolin-3-one [EC no. 247-500-7]<br>and 2-methyl-4-isothiazolin-3-one [EC no. 220-239-6] (3:1) |                             | —         | 55965-84-9 | T; R23/24/25<br>C; R34<br>R43<br>N; R50-53            | T; N<br>R: 23/24/25-34-43-50/53<br>S: (2-)26-28-36/37/39-45-60-61 | C ≥ 25 %: T, N; R23/24/25-34-43-50/53<br>3 % ≤ C < 25 %: C, N; R20/21/22-34-43-51/53<br>2,5 % ≤ C < 3 %: C, N; R34-43-51/53<br>0,6 % ≤ C < 2,5 %: Xi; R34-43-52/53<br>0,25 % ≤ C < 0,6 %: Xi; R33/38-43-52/53<br>0,06 % ≤ C < 0,25 %: Xi; R36/38-43<br>0,0015 % ≤ C < 0,06 %: Xi; R43 |                               |

| Index No     | chemical name   | Notes related to substances | EC No   | CAS No  | Classification  | Labelling  | Concentration Limits  | Notes related to preparations |
|--------------|---|-----------------------------|---|---|---|--|---|-------------------------------|
| 613-175-00-9 | Epoxiconazole<br>(2 <i>RS</i> ,3 <i>SR</i> )-3-(2-chlorophenyl)-2-(4-fluorophenyl)-[(1 <i>H</i> -1,2,4-triazol-1-yl)methyl]oxirane  |                             | 406-850-2                                       | 133855-98-8                                   | Carc. Cat. 3; R40<br>Repr. Cat. 3; R62<br>Repr. Cat. 3; R63<br>N; R51-53      | Xn; N<br>R: 40-62-63-51/53<br>S: (2-)36/37-46-61                               |   |                               |
| 615-001-00-7 | methyl isocyanate   |                             | 210-866-3                                       | 624-83-9                                      | F+; R12<br>Repr.Cat.3; R63<br>T+; R26<br>T; R24/25<br>R42/43<br>Xi; R37/38-41 | F+; T+<br>R: 12-24/25-26-37/38-41-42/43-63<br>S: (1/2-)26-27/28-36/37/39-45-63 |   |                               |
| 615-004-00-3 | salts of thiocyanic acid  | A                           | —   | —   | Xn; R20/21/22<br>R32<br>R52-53  | Xn<br>R: 20/21/22-32-52/53<br>S: (2-)13-61                                     |   |                               |
| 615-006-00-4 | 2-methyl- <i>m</i> -phenylene diisocyanate<br>toluene-2,4-di-isocyanate [1]<br>4-methyl- <i>m</i> -phenylene diisocyanate<br>toluene-2,6-di-isocyanate [2]<br><i>m</i> -tolylidene diisocyanate<br>toluene-diisocyanate [3] |                             | 202-039-0 [1]<br>209-544-5 [2]<br>247-722-4 [3] | 91-08-7 [1]<br>584-84-9 [2]<br>26471-62-5 [3] | Carc. Cat. 3; R40<br>T+; R26<br>Xi; R36/37/38<br>R42/43<br>R52-53             | T+<br>R: 26-36/37/38-40-42/43-52/53<br>S: (1/2-)23-36/37-45-61                 | C ≥ 25 %: T+; R26-36/37/38-40-42/43-52/53<br>20 % ≤ C < 25 %: T+; R26-36/37/38-40-42/43<br>7 % ≤ C < 20 %: T+; R26-40-42/43<br>1 % ≤ C < 7 %: T; R23-40-42/43<br>0,1 % ≤ C < 1 %: Xn; R20-42        |                               |
| 615-008-00-5 | 3-isocyanatomethyl-3,5,5-trimethylcyclohexyl isocyanate<br>isophorone di-isocyanate   |                             | 223-861-6                                       | 4098-71-9                                     | T; R23<br>Xi; R36/37/38<br>R42/43<br>N; R51-53                                | T; N<br>R: 23-36/37/38-42/43-51/53<br>S: (1/2-)26-28-38-45-61                  | C ≥ 25 %: T, N; R23-36/37/38-42/43-51/53<br>20 % ≤ C < 25 %: T; R23-36/37/38-42/43-52/53<br>2,5 % ≤ C < 20 %: T; R23-42/43-52/53<br>2 % ≤ C < 2,5 %: T; R23-42/43<br>0,5 % ≤ C < 2 %: Xn; R20-42/43 | 2                             |
| 615-015-00-3 | 1,7,7-trimethylbicyclo(2,2,1)-hept-2-yl thiocyanatoacetate<br>isobornyl thiocyanatoacetate  |                             | 204-081-5                                       | 115-31-1                                      | Xn; R22<br>N; R50-53  | Xn; N<br>R: 22-50/53<br>S: (2-)24/25-60-61                                     |   |                               |

| Index No     | chemical name  | Notes related to substances | EC No     | CAS No     | Classification  | Labelling   | Concentration Limits   | Notes related to preparations |
|--------------|--|-----------------------------|-----------|------------|---|---|--|-------------------------------|
| 616-015-00-6 | alachlor (ISO)<br>2-chloro-2',6'-diethyl-N-(methoxymethyl)acetanilide  |                             | 240-110-8 | 15972-60-8 | Carc. Cat. 3; R40<br>Xn; R22<br>R43<br>N; R50-53              | Xn; N<br>R: 22-40-43-50/53<br>S: (2-)36/37-46-60-61                                     | C ≥ 25 %: Xn, N; R22-40-43-50-53<br>1 % ≤ C < 25 %: Xn, N; R40-43-50-53<br>0,25 % ≤ C < 1 %: N; R50-53<br>0,025 % ≤ C < 0,25 %: N; R51-53<br>0,0025 % ≤ C < 0,025 %: R52-53                            |                               |
| 616-024-00-5 | 2-(4,4-dimethyl-2,5-dioxooxazolidin-1-yl)-2-chloro-5-(2-(2,4-ditert-pentylphenoxy)butyramido)-4,4-dimethyl-3-oxovaleranilide   |                             | 402-260-4 | —          | R53   | R: 53<br>S: 61  |  |                               |
| 617-002-00-8 | α,α-dimethylbenzyl hydroperoxide<br>cumene hydroperoxide   |                             | 201-254-7 | 80-15-9    | O; R7<br>T; R23<br>Xn; R21/22-48/20/22<br>C; R34<br>N; R51-53 | O; T; N<br>R: 7-21/22-23-34-48/<br>20/22-51/53<br>S: (1/2-)3/7-14-36/37/<br>39-45-50-61 | C ≥ 25 %: T, N; R21/22-23-34-48/20/22-51/53<br>10 % ≤ C < 25 %: C; R20-34-48/20/22-52/53<br>3 % ≤ C < 10 %: Xn; R20-37/38-41-52/53<br>2,5 % ≤ C < 3 %: Xi; R36/37-52/53<br>1 % ≤ C < 2,5 %: Xi; R36/37 |                               |
| 617-004-00-9 | 1,2,3,4-tetrahydro-1-naphthyl hydroperoxide  |                             | 212-230-0 | 771-29-9   | O; R7<br>Xn; R22<br>C; R34<br>N; R50-53                       | O; C; N<br>R: 7-22-34-50/53<br>S: (1/2-)3/7-14-26-36/<br>37/39-45-60-61                 | C ≥ 25 %: C, N; R22-34-50/53<br>10 % ≤ C < 25 %: C, N; R34-51/53<br>5 % ≤ C < 10 %: Xi, N; R36/37/38-51/53<br>2,5 % ≤ C < 5 %: N; R51/53<br>0,25 % ≤ C < 2,5 %: R52/53                                 |                               |
| 648-043-00-X | Creosote oil, acenaphthene fraction, acenaphthene-free Wash Oil Redistillate<br>[The oil remaining after removal by a crystallization process of acenaphthene from acenaphthene oil from coal tar. Composed primarily of naphthalene and alkylnaphthalenes.] | H                           | 292-606-9 | 90640-85-0 | Carc. Cat. 2; R45   | T<br>R: 45<br>S: 53-45  |  |                               |

| Index No     | chemical name  | Notes related to substances | EC No     | CAS No     | Classification    | Labelling              | Concentration Limits | Notes related to preparations |
|--------------|--|-----------------------------|-----------|------------|-------------------|------------------------|----------------------|-------------------------------|
| 648-080-00-1 | Residues (coal tar), creosote oil distn.<br>Wash Oil Redistillate<br>[The residue from the fractional distillation of wash oil boiling in the approximate range of 270 °C to 330 °C (518 °F to 626 °F). It consists predominantly of dinuclear aromatic and heterocyclic hydrocarbons.]          | H                           | 295-506-3 | 92061-93-3 | Carc. Cat. 2; R45 | T<br>R: 45<br>S: 53-45 |                      |                               |
| 648-098-00-X | Creosote oil, acenaphthene fraction<br>Wash Oil<br>[A complex combination of hydrocarbons produced by the distillation of coal tar and boiling in the range of approximately 240 °C to 280 °C (464 °F to 536 °F). Composed primarily of acenaphthene, naphthalene and alkyl naphthalene.]        | H                           | 292-605-3 | 90640-84-9 | Carc. Cat. 2; R45 | T<br>R: 45<br>S: 53-45 |                      |                               |
| 648-099-00-5 | Creosote oil<br>[A complex combination of hydrocarbons obtained by the distillation of coal tar. It consists primarily of aromatic hydrocarbons and may contain appreciable quantities of tar acids and tar bases. It distills at the approximate range of 200 °C to 325 °C (392 °F to 617 °F).] | H                           | 263-047-8 | 61789-28-4 | Carc. Cat. 2; R45 | T<br>R: 45<br>S: 53-45 |                      |                               |



| Index No     | chemical name   | Notes related to substances | EC No     | CAS No      | Classification    | Labelling              | Concentration Limits | Notes related to preparations |
|--------------|---|-----------------------------|-----------|-------------|-------------------|------------------------|----------------------|-------------------------------|
| 648-100-00-9 | Creosote oil, high-boiling distillate<br>Wash Oil<br>[The high-boiling distillation fraction obtained from the high temperature carbonization of bituminous coal which is further refined to remove excess crystalline salts. It consists primarily of creosote oil with some of the normal polynuclear aromatic salts, which are components of coal tar distillates, removed. It is crystal free at approximately 5 °C (41 °F).] | H                           | 274-565-9 | 70321-79-8  | Carc. Cat. 2; R45 | T<br>R: 45<br>S: 53-45 |                      |                               |
| 648-101-00-4 | Creosote<br>[The distillate of coal tar produced by the high temperature carbonization of bituminous coal. It consists primarily of aromatic hydrocarbons, tar acids and tar bases.]  | H                           | 232-287-5 | 8001-58-9   | Carc. Cat. 2; R45 | T<br>R: 45<br>S: 53-45 |                      |                               |
| 648-102-00-X | Extract residues (coal), creosote oil acid<br>Wash Oil Extract Residue<br>[A complex combination of hydrocarbons from the base-freed fraction from the distillation of coal tar, boiling in the range of approximately 250 °C to 280 °C (482 °F to 536 °F). It consists predominantly of biphenyl and isomeric diphenylnaphthalenes.]   | H                           | 310-189-4 | 122384-77-4 | Carc. Cat. 2; R45 | T<br>R: 45<br>S: 53-45 |                      |                               |

| Index No     | chemical name   | Notes related to substances | EC No     | CAS No     | Classification    | Labelling              | Concentration Limits | Notes related to preparations |
|--------------|---|-----------------------------|-----------|------------|-------------------|------------------------|----------------------|-------------------------------|
| 648-138-00-6 | Creosote oil, low-boiling distillate<br>Wash Oil<br>[The low-boiling distillation fraction obtained from the high temperature carbonization of bituminous coal, which is further refined to remove excess crystalline salts. It consists primarily of creosote oil with some of the normal polynuclear aromatic salts, which are components of coal tar distillate, removed. It is crystal free at approximately 38 °C (100 °F).] | H                           | 274-566-4 | 70321-80-1 | Carc. Cat. 2; R45 | T<br>R: 45<br>S: 53-45 |                      |                               |
| 649-001-00-3 | Extracts (petroleum), light naphthenic distillate solvent   | H                           | 265-102-1 | 64742-03-6 | Carc. Cat. 2; R45 | T<br>R: 45<br>S: 53-45 |                      |                               |
| 649-002-00-9 | Extracts (petroleum), heavy paraffinic distillate solvent   | H                           | 265-103-7 | 64742-04-7 | Carc. Cat. 2; R45 | T<br>R: 45<br>S: 53-45 |                      |                               |
| 649-003-00-4 | Extracts (petroleum), light paraffinic distillate solvent   | H                           | 265-104-2 | 64742-05-8 | Carc. Cat. 2; R45 | T<br>R: 45<br>S: 53-45 |                      |                               |
| 649-004-00-X | Extracts (petroleum), heavy naphthenic distillate solvent   | H                           | 265-111-0 | 64742-11-6 | Carc. Cat. 2; R45 | T<br>R: 45<br>S: 53-45 |                      |                               |
| 649-005-00-5 | Extracts (petroleum), light vacuum gas oil solvent  | H                           | 295-341-7 | 91995-78-7 | Carc. Cat. 2; R45 | T<br>R: 45<br>S: 53-45 |                      |                               |
| 649-006-00-0 | hydrocarbons C <sub>26-55</sub> , arom-rich   | H                           | 307-753-7 | 97722-04-8 | Carc. Cat. 2; R45 | T<br>R: 45<br>S: 53-45 |                      |                               |

| Index No     | chemical name   | Notes related to substances | EC No     | CAS No     | Classification                         | Labelling                 | Concentration Limits | Notes related to preparations |
|--------------|---|-----------------------------|-----------|------------|--|---------------------------|----------------------|-------------------------------|
| 649-062-00-6 | Gases (petroleum), catalytic cracked naphtha depropanizer overhead, C <sub>3</sub> -rich acid-free Petroleum gas<br>[A complex combination of hydrocarbons obtained from fractionation of catalytic cracked hydrocarbons and treated to remove acidic impurities. It consists of hydrocarbons having carbon numbers in the range of C <sub>2</sub> through C <sub>4</sub> , predominantly C <sub>3</sub> .] | H K                         | 270-755-0 | 68477-73-6 | Carc. Cat. 1; R45<br>Muta. Cat. 2; R46 | T<br>R: 45-46<br>S: 53-45 |                      |                               |
| 649-063-00-1 | Gases (petroleum), catalytic cracker Petroleum gas<br>[A complex combination of hydrocarbons produced by the distillation of the products from a catalytic cracking process. It consists predominantly of aliphatic hydrocarbons having carbon numbers predominantly in the range of C <sub>1</sub> through C <sub>6</sub> .]   | H K                         | 270-756-6 | 68477-74-7 | Carc. Cat. 1; R45<br>Muta. Cat. 2; R46 | T<br>R: 45-46<br>S: 53-45 |                      |                               |
| 649-064-00-7 | Gases (petroleum), catalytic cracker, C <sub>1-5</sub> -rich Petroleum gas<br>[A complex combination of hydrocarbons produced by the distillation of products from a catalytic cracking process. It consists of aliphatic hydrocarbons having carbon numbers in the range of C <sub>1</sub> through C <sub>6</sub> , predominantly C <sub>1</sub> through C <sub>5</sub> .]                                 | H K                         | 270-757-1 | 68477-75-8 | Carc. Cat. 1; R45<br>Muta. Cat. 2; R46 | T<br>R: 45-46<br>S: 53-45 |                      |                               |

| Index No     | chemical name  | Notes related to substances | EC No     | CAS No     | Classification                         | Labelling                 | Concentration Limits | Notes related to preparations |
|--------------|--|-----------------------------|-----------|------------|--|---------------------------|----------------------|-------------------------------|
| 649-065-00-2 | Gases (petroleum), catalytic polymd. naphtha stabilizer overhead, C <sub>2-4</sub> -rich<br>Petroleum gas<br>[A complex combination of hydrocarbons obtained from the fractionation stabilization of catalytic polymerized naphtha. It consists of aliphatic hydrocarbons having carbon numbers in the range of C <sub>2</sub> through C <sub>6</sub> , predominantly C <sub>2</sub> through C <sub>4</sub> .] | H K                         | 270-758-7 | 68477-76-9 | Carc. Cat. 1; R45<br>Muta. Cat. 2; R46 | T<br>R: 45-46<br>S: 53-45 |                      |                               |
| 649-066-00-8 | Gases (petroleum), catalytic reformer, C <sub>1-4</sub> -rich<br>Petroleum gas<br>[A complex combination of hydrocarbons produced by distillation of products from a catalytic reforming process. It consists of hydrocarbons having carbon numbers in the range of C <sub>1</sub> through C <sub>6</sub> , predominantly C <sub>1</sub> through C <sub>4</sub> .]   | H K                         | 270-760-8 | 68477-79-2 | Carc. Cat. 1; R45<br>Muta. Cat. 2; R46 | T<br>R: 45-46<br>S: 53-45 |                      |                               |
| 649-067-00-3 | Gases (petroleum), C <sub>3-5</sub> olefinic-paraffinic alkylation feed<br>Petroleum gas<br>[A complex combination of olefinic and paraffinic hydrocarbons having carbon numbers in the range of C <sub>3</sub> through C <sub>5</sub> which are used as alkylation feed. Ambient temperatures normally exceed the critical temperature of these combinations.]  | H K                         | 270-765-5 | 68477-83-8 | Carc. Cat. 1; R45<br>Muta. Cat. 2; R46 | T<br>R: 45-46<br>S: 53-45 |                      |                               |

| Index No     | chemical name  | Notes related to substances | EC No     | CAS No     | Classification                         | Labelling                 | Concentration Limits | Notes related to preparations |
|--------------|--|-----------------------------|-----------|------------|--|---------------------------|----------------------|-------------------------------|
| 649-068-00-9 | Gases (petroleum), C <sub>4</sub> -rich Petroleum gas<br>[A complex combination of hydrocarbons produced by distillation of products from a catalytic fractionation process. It consists of aliphatic hydrocarbons having carbon numbers in the range of C <sub>3</sub> through C <sub>5</sub> , predominantly C <sub>4</sub> .] | H K                         | 270-767-6 | 68477-85-0 | Carc. Cat. 1; R45<br>Muta. Cat. 2; R46 | T<br>R: 45-46<br>S: 53-45 |                      |                               |
| 649-069-00-4 | Gases (petroleum), deethanizer overheads<br>Petroleum gas<br>[A complex combination of hydrocarbons produced from distillation of the gas and gasoline fractions from the catalytic cracking process. It contains predominantly ethane and ethylene.]  | H K                         | 270-768-1 | 68477-86-1 | Carc. Cat. 1; R45<br>Muta. Cat. 2; R46 | T<br>R: 45-46<br>S: 53-45 |                      |                               |
| 649-070-00-X | Gases (petroleum), deisobutanizer tower overheads<br>Petroleum gas<br>[A complex combination of hydrocarbons produced by the atmospheric distillation of a butane-butylene stream. It consists of aliphatic hydrocarbons having carbon numbers predominantly in the range of C <sub>3</sub> through C <sub>4</sub> .]            | H K                         | 270-769-7 | 68477-87-2 | Carc. Cat. 1; R45<br>Muta. Cat. 2; R46 | T<br>R: 45-46<br>S: 53-45 |                      |                               |
| 649-071-00-5 | Gases (petroleum), depropanizer dry, propene-rich<br>Petroleum gas<br>[A complex combination of hydrocarbons produced by the distillation of products from the gas and gasoline fractions of a catalytic cracking process. It consists predominantly of propylene with some ethane and propane.]                                 | H K                         | 270-772-3 | 68477-90-7 | Carc. Cat. 1; R45<br>Muta. Cat. 2; R46 | T<br>R: 45-46<br>S: 53-45 |                      |                               |

| Index No     | chemical name   | Notes related to substances | EC No     | CAS No     | Classification                         | Labelling                 | Concentration Limits | Notes related to preparations |
|--------------|---|-----------------------------|-----------|------------|--|---------------------------|----------------------|-------------------------------|
| 649-072-00-0 | Gases (petroleum), depropanizer overheads<br>Petroleum gas<br>[A complex combination of hydrocarbons produced by distillation of products from the gas and gasoline fractions of a catalytic cracking process. It consists of aliphatic hydrocarbons having carbon numbers predominantly in the range of C <sub>2</sub> through C <sub>4</sub> .] | H K                         | 270-773-9 | 68477-91-8 | Carc. Cat. 1; R45<br>Muta. Cat. 2; R46 | T<br>R: 45-46<br>S: 53-45 |                      |                               |
| 649-073-00-6 | Gases (petroleum), gas recovery plant depropanizer overheads<br>Petroleum gas<br>[A complex combination of hydrocarbons obtained by fractionation of miscellaneous hydrocarbon streams. It consists predominantly of hydrocarbons having carbon numbers in the range of C <sub>1</sub> through C <sub>4</sub> , predominantly propane.]           | H K                         | 270-777-0 | 68477-94-1 | Carc. Cat. 1; R45<br>Muta. Cat. 2; R46 | T<br>R: 45-46<br>S: 53-45 |                      |                               |
| 649-074-00-1 | Gases (petroleum), Girbatol unit feed<br>Petroleum gas<br>[A complex combination of hydrocarbons that is used as the feed into the Girbatol unit to remove hydrogen sulfide. It consists of aliphatic hydrocarbons having carbon numbers predominantly in the range of C <sub>2</sub> through C <sub>4</sub> .]                                   | H K                         | 270-778-6 | 68477-95-2 | Carc. Cat. 1; R45<br>Muta. Cat. 2; R46 | T<br>R: 45-46<br>S: 53-45 |                      |                               |

| Index No     | chemical name   | Notes related to substances | EC No     | CAS No     | Classification                         | Labelling                 | Concentration Limits | Notes related to preparations |
|--------------|---|-----------------------------|-----------|------------|--|---------------------------|----------------------|-------------------------------|
| 649-075-00-7 | Gases (petroleum), isomerized naphtha fractionator, C <sub>4</sub> -rich, hydrogen sulfide-free<br>Petroleum gas  | H K                         | 270-782-8 | 68477-99-6 | Carc. Cat. 1; R45<br>Muta. Cat. 2; R46 | T<br>R: 45-46<br>S: 53-45 |                      |                               |
| 649-076-00-2 | Tail gas (petroleum), catalytic cracked clarified oil and thermal cracked vacuum residue fractionation reflux drum<br>Petroleum gas<br>[A complex combination of hydrocarbons obtained from fractionation of catalytic cracked clarified oil and thermal cracked vacuum residue. It consists predominantly of hydrocarbons having carbon numbers predominantly in the range of C <sub>1</sub> through C <sub>6</sub> .] | H K                         | 270-802-5 | 68478-21-7 | Carc. Cat. 1; R45<br>Muta. Cat. 2; R46 | T<br>R: 45-46<br>S: 53-45 |                      |                               |
| 649-077-00-8 | Tail gas (petroleum), catalytic cracked naphtha stabilization absorber<br>Petroleum gas<br>[A complex combination of hydrocarbons obtained from the stabilization of catalytic cracked naphtha. It consists predominantly of hydrocarbons having carbon numbers predominantly in the range of C <sub>1</sub> through C <sub>6</sub> .]  | H K                         | 270-803-0 | 68478-22-8 | Carc. Cat. 1; R45<br>Muta. Cat. 2; R46 | T<br>R: 45-46<br>S: 53-45 |                      |                               |

| Index No     | chemical name  | Notes related to substances | EC No     | CAS No     | Classification                         | Labelling                 | Concentration Limits | Notes related to preparations |
|--------------|--|-----------------------------|-----------|------------|--|---------------------------|----------------------|-------------------------------|
| 649-078-00-3 | Tail gas (petroleum), catalytic cracker, catalytic reformer and hydrodesulfurizer combined fractionater<br>Petroleum gas<br>[A complex combination of hydrocarbons obtained from the fractionation of products from catalytic cracking, catalytic reforming and hydrodesulfurizing processes treated to remove acidic impurities. It consists predominantly of hydrocarbons having carbon numbers predominantly in the range of C <sub>1</sub> through C <sub>5</sub> .] | H K                         | 270-804-6 | 68478-24-0 | Carc. Cat. 1; R45<br>Muta. Cat. 2; R46 | T<br>R: 45-46<br>S: 53-45 |                      |                               |
| 649-079-00-9 | Tail gas (petroleum), catalytic reformed naphtha fractionation stabilizer<br>Petroleum gas<br>[A complex combination of hydrocarbons obtained from the fractionation stabilization of catalytic reformed naphtha. It consists predominantly of hydrocarbons having carbon numbers predominantly in the range of C <sub>1</sub> through C <sub>4</sub> .]   | H K                         | 270-806-7 | 68478-26-2 | Carc. Cat. 1; R45<br>Muta. Cat. 2; R46 | T<br>R: 45-46<br>S: 53-45 |                      |                               |



| Index No     | chemical name  | Notes related to substances | EC No     | CAS No     | Classification                         | Labelling                 | Concentration Limits | Notes related to preparations |
|--------------|--|-----------------------------|-----------|------------|--|---------------------------|----------------------|-------------------------------|
| 649-080-00-4 | Tail gas (petroleum), saturate gas plant mixed stream, C <sub>4</sub> -rich<br>Petroleum gas<br>[A complex combination of hydrocarbons obtained from the fractionation stabilization of straight-run naphtha, distillation tail gas and catalytic reformed naphtha stabilizer tail gas. It consists of hydrocarbons having carbon numbers in the range of C <sub>3</sub> through C <sub>6</sub> , predominantly butane and isobutane.] | H K                         | 270-813-5 | 68478-32-0 | Carc. Cat. 1; R45<br>Muta. Cat. 2; R46 | T<br>R: 45-46<br>S: 53-45 |                      |                               |
| 649-081-00-X | Tail gas (petroleum), saturate gas recovery plant, C <sub>1-2</sub> -rich<br>Petroleum gas<br>[A complex combination of hydrocarbons obtained from fractionation of distillate tail gas, straight-run naphtha, catalytic reformed naphtha stabilizer tail gas. It consists predominantly of hydrocarbons having carbon numbers in the range of C <sub>1</sub> through C <sub>5</sub> , predominantly methane and ethane.]              | H K                         | 270-814-0 | 68478-33-1 | Carc. Cat. 1; R45<br>Muta. Cat. 2; R46 | T<br>R: 45-46<br>S: 53-45 |                      |                               |
| 649-082-00-5 | Tail gas (petroleum), vacuum residues thermal cracker<br>Petroleum gas<br>[A complex combination of hydrocarbons obtained from the thermal cracking of vacuum residues. It consists of hydrocarbons having carbon numbers predominantly in the range of C <sub>1</sub> through C <sub>5</sub> .]   | H K                         | 270-815-6 | 68478-34-2 | Carc. Cat. 1; R45<br>Muta. Cat. 2; R46 | T<br>R: 45-46<br>S: 53-45 |                      |                               |

| Index No     | chemical name   | Notes related to substances | EC No     | CAS No     | Classification                         | Labelling                 | Concentration Limits | Notes related to preparations |
|--------------|---|-----------------------------|-----------|------------|--|---------------------------|----------------------|-------------------------------|
| 649-083-00-0 | Hydrocarbons, C <sub>3-4</sub> -rich, petroleum distillate<br>Petroleum gas<br>[A complex combination of hydrocarbons produced by distillation and condensation of crude oil. It consists of hydrocarbons having carbon numbers in the range of C <sub>3</sub> through C <sub>5</sub> , predominantly C <sub>3</sub> through C <sub>4</sub> .]  | H K                         | 270-990-9 | 68512-91-4 | Carc. Cat. 1; R45<br>Muta. Cat. 2; R46 | T<br>R: 45-46<br>S: 53-45 |                      |                               |
| 649-084-00-6 | Gases (petroleum), full-range straight-run naphtha dehexanizer off petroleum gas<br>[A complex combination of hydrocarbons obtained by the fractionation of the full-range straight-run naphtha. It consists of hydrocarbons having carbon numbers predominantly in the range of C <sub>2</sub> through C <sub>6</sub> .]   | H K                         | 271-000-8 | 68513-15-5 | Carc. Cat. 1; R45<br>Muta. Cat. 2; R46 | T<br>R: 45-46<br>S: 53-45 |                      |                               |
| 649-085-00-1 | Gases (petroleum), hydrocracking depropanizer off, hydrocarbon-rich<br>Petroleum gas<br>[A complex combination of hydrocarbon produced by the distillation of products from a hydrocracking process. It consists predominantly of hydrocarbons having carbon numbers predominantly in the range of C <sub>1</sub> through C <sub>4</sub> . It may also contain small amounts of hydrogen and hydrogen sulfide.] | H K                         | 271-001-3 | 68513-16-6 | Carc. Cat. 1; R45<br>Muta. Cat. 2; R46 | T<br>R: 45-46<br>S: 53-45 |                      |                               |

| Index No     | chemical name  | Notes related to substances | EC No     | CAS No     | Classification                         | Labelling                 | Concentration Limits | Notes related to preparations |
|--------------|--|-----------------------------|-----------|------------|--|---------------------------|----------------------|-------------------------------|
| 649-086-00-7 | Gases (petroleum), light straight-run naphtha stabilizer off<br>Petroleum gas<br>[A complex combination of hydrocarbons obtained by the stabilization of light straight-run naphtha. It consists of saturated aliphatic hydrocarbons having carbon numbers predominantly in the range of C <sub>2</sub> through C <sub>6</sub> .]  | H K                         | 271-002-9 | 68513-17-7 | Carc. Cat. 1; R45<br>Muta. Cat. 2; R46 | T<br>R: 45-46<br>S: 53-45 |                      |                               |
| 649-087-00-2 | Residues (petroleum), alkylation splitter, C <sub>4</sub> -rich<br>Petroleum gas<br>[A complex residuum from the distillation of streams various refinery operations. It consists of hydrocarbons having carbon numbers in the range of C <sub>4</sub> through C <sub>5</sub> , predominantly butane and boiling in the range of approximately -11.7 °C to 27.8 °C (11 °F to 82 °F).]              | H K                         | 271-010-2 | 68513-66-6 | Carc. Cat. 1; R45<br>Muta. Cat. 2; R46 | T<br>R: 45-46<br>S: 53-45 |                      |                               |
| 649-088-00-8 | Hydrocarbons, C <sub>1-4</sub><br>Petroleum gas<br>[A complex combination of hydrocarbons provided by thermal cracking and absorber operations and by distillation of crude oil. It consists of hydrocarbons having carbon numbers predominantly in the range of C <sub>1</sub> through C <sub>4</sub> and boiling in the range of approximately minus 164 °C to minus 0.5 °C (-263 °F to 31 °F).] | H K                         | 271-032-2 | 68514-31-8 | Carc. Cat 1; R45<br>Muta. Cat. 2; R46  | T<br>R: 45-46<br>S: 53-45 |                      |                               |

| Index No     | chemical name   | Notes related to substances | EC No     | CAS No     | Classification                         | Labelling                 | Concentration Limits | Notes related to preparations |
|--------------|---|-----------------------------|-----------|------------|--|---------------------------|----------------------|-------------------------------|
| 649-089-00-3 | Hydrocarbons, C <sub>1-4</sub> , sweetened Petroleum gas<br>[A complex combination of hydrocarbons obtained by subjecting hydrocarbon gases to a sweetening process to convert mercaptans or to remove acidic impurities. It consists of hydrocarbons having carbon numbers predominantly in the range of C <sub>1</sub> through C <sub>4</sub> and boiling in the range of approximately -164 °C to -0.5 °C (-263 °F to 31 °F).] | H K                         | 271-038-5 | 68514-36-3 | Carc. Cat. 1; R45<br>Muta. Cat. 2; R46 | T<br>R: 45-46<br>S: 53-45 |                      |                               |
| 649-090-00-9 | Hydrocarbons, C <sub>1-3</sub> Petroleum gas<br>[A complex combination of hydrocarbons having carbon numbers predominantly in the range of C <sub>1</sub> through C <sub>3</sub> and boiling in the range of approximately minus 164 °C to minus 42 °C (-263 °F to -44 °F).]  | H K                         | 271-259-7 | 68527-16-2 | Carc. Cat. 1; R45<br>Muta. Cat. 2; R46 | T<br>R: 45-46<br>S: 53-45 |                      |                               |
| 649-091-00-4 | Hydrocarbons, C <sub>1-4</sub> , debutanizer fraction<br>Petroleum gas  | H K                         | 271-261-8 | 68527-19-5 | Carc. Cat. 1; R45<br>Muta. Cat. 2; R46 | T<br>R: 45-46<br>S: 53-45 |                      |                               |
| 649-092-00-X | Gases (petroleum), C <sub>1-5</sub> , wet<br>Petroleum gas<br>[A complex combination of hydrocarbons produced by the distillation of crude oil and/or the cracking of tower gas oil. It consists of hydrocarbons having carbon numbers predominantly in the range of C <sub>1</sub> through C <sub>5</sub> .]   | H K                         | 271-624-0 | 68602-83-5 | Carc. Cat. 1; R45<br>Muta. Cat. 2; R46 | T<br>R: 45-46<br>S: 53-45 |                      |                               |
| 649-093-00-5 | Hydrocarbons, C <sub>2-4</sub><br>Petroleum gas   | H K                         | 271-734-9 | 68606-25-7 | Carc. Cat. 1; R45<br>Muta. Cat. 2; R46 | T<br>R: 45-46<br>S: 53-45 |                      |                               |

| Index No     | chemical name   | Notes related to substances | EC No     | CAS No     | Classification                         | Labelling                 | Concentration Limits | Notes related to preparations |
|--------------|---|-----------------------------|-----------|------------|--|---------------------------|----------------------|-------------------------------|
| 649-094-00-0 | Hydrocarbons, C <sub>3</sub><br>Petroleum gas   | H K                         | 271-735-4 | 68606-26-8 | Carc. Cat. 1; R45<br>Muta. Cat. 2; R46 | T<br>R: 45-46<br>S: 53-45 |                      |                               |
| 649-095-00-6 | Gases (petroleum), alkylation feed<br>Petroleum gas<br>[A complex combination of hydrocarbons produced by the catalytic cracking of gas oil. It consists of hydrocarbons having carbon numbers predominantly in the range of C <sub>3</sub> through C <sub>4</sub> .] | H K                         | 271-737-5 | 68606-27-9 | Carc. Cat. 1; R45<br>Muta. Cat. 2; R46 | T<br>R: 45-46<br>S: 53-45 |                      |                               |
| 649-096-00-1 | Gases (petroleum), depropanizer bottoms fractionation off<br>Petroleum gas<br>[A complex combination of hydrocarbons obtained from the fractionation of depropanizer bottoms. It consists predominantly of butane, isobutane and butadiene.]                          | H K                         | 271-742-2 | 68606-34-8 | Carc. Cat. 1; R45<br>Muta. Cat. 2; R46 | T<br>R: 45-46<br>S: 53-45 |                      |                               |
| 649-097-00-7 | Gases (petroleum), refinery blend<br>Petroleum gas<br>[A complex combination obtained from various processes. It consists of hydrogen, hydrogen sulfide and hydrocarbons having carbon numbers predominantly in the range of C <sub>1</sub> through C <sub>5</sub> .] | H K                         | 272-183-7 | 68783-07-3 | Carc. Cat. 1; R45<br>Muta. Cat. 2; R46 | T<br>R: 45-46<br>S: 53-45 |                      |                               |

| Index No     | chemical name  | Notes related to substances | EC No     | CAS No     | Classification                         | Labelling                 | Concentration Limits | Notes related to preparations |
|--------------|--|-----------------------------|-----------|------------|--|---------------------------|----------------------|-------------------------------|
| 649-098-00-2 | Gases (petroleum), catalytic cracking<br>Petroleum gas<br>[A complex combination of hydrocarbons produced by the distillation of the products from a catalytic cracking process. It consists predominantly of hydrocarbons having carbon numbers predominantly in the range of C <sub>3</sub> through C <sub>5</sub> .]  | H K                         | 272-203-4 | 68783-64-2 | Carc. Cat. 1; R45<br>Muta. Cat. 2; R46 | T<br>R: 45-46<br>S: 53-45 |                      |                               |
| 649-099-00-8 | Gases (petroleum), C <sub>2-4</sub> , sweetened<br>Petroleum gas<br>[A complex combination of hydrocarbons obtained by subjecting a petroleum distillate to a sweetening process to convert mercaptans or to remove acidic impurities. It consists predominantly of saturated and unsaturated hydrocarbons having carbon numbers predominantly in the range of C <sub>2</sub> through C <sub>4</sub> and boiling in the range of approximately -51 °C to -34 °C (-60 °F to -30 °F).] | H K                         | 272-205-5 | 68783-65-3 | Carc. Cat. 1; R45<br>Muta. Cat. 2; R46 | T<br>R: 45-46<br>S: 53-45 |                      |                               |
| 649-100-00-1 | Gases (petroleum), crude oil fractionation off<br>Petroleum gas<br>[A complex combination of hydrocarbons produced by the fractionation of crude oil. It consists of saturated aliphatic hydrocarbons having carbon numbers predominantly in the range of C <sub>1</sub> through C <sub>5</sub> .]   | H K                         | 272-871-7 | 68918-99-0 | Carc. Cat. 1; R45<br>Muta. Cat. 2; R46 | T<br>R: 45-46<br>S: 53-45 |                      |                               |

| Index No     | chemical name  | Notes related to substances | EC No     | CAS No     | Classification                         | Labelling                 | Concentration Limits | Notes related to preparations |
|--------------|--|-----------------------------|-----------|------------|--|---------------------------|----------------------|-------------------------------|
| 649-101-00-7 | Gases (petroleum), dehexanizer off<br>Petroleum gas<br>[A complex combination of hydrocarbons obtained by the fractionation of combined naphtha streams. It consists of saturated aliphatic hydrocarbons having carbon numbers predominantly in the range of C <sub>1</sub> through C <sub>5</sub> .]  | H K                         | 272-872-2 | 68919-00-6 | Carc. Cat. 1; R45<br>Muta. Cat. 2; R46 | T<br>R: 45-46<br>S: 53-45 |                      |                               |
| 649-102-00-2 | Gases (petroleum), light straight run gasoline fractionation stabilizer off<br>Petroleum gas<br>[A complex combination of hydrocarbons obtained by the fractionation of light straight-run gasoline. It consists of saturated aliphatic hydrocarbons having carbon numbers predominantly in the range of C <sub>1</sub> through C <sub>5</sub> .]                    | H K                         | 272-878-5 | 68919-05-1 | Carc. Cat. 1; R45<br>Muta. Cat. 2; R46 | T<br>R: 45-46<br>S: 53-45 |                      |                               |
| 649-103-00-8 | Gases (petroleum), naphtha unifier desulfurization stripper off<br>Petroleum gas<br>[A complex combination of hydrocarbons produced by a naphtha unifier desulfurization process and stripped from the naphtha product. It consists of saturated aliphatic hydrocarbons having carbon numbers predominantly in the range of C <sub>1</sub> through C <sub>4</sub> .] | H K                         | 272-879-0 | 68919-06-2 | Carc. Cat. 1; R45<br>Muta. Cat. 2; R46 | T<br>R: 45-46<br>S: 53-45 |                      |                               |

| Index No     | chemical name  | Notes related to substances | EC No     | CAS No     | Classification                         | Labelling                 | Concentration Limits | Notes related to preparations |
|--------------|--|-----------------------------|-----------|------------|--|---------------------------|----------------------|-------------------------------|
| 649-104-00-3 | Gases (petroleum), straight-run naphtha catalytic reforming off<br>Petroleum gas<br>[A complex combination of hydrocarbons obtained by the catalytic reforming of straight-run naphtha and fractionation of the total effluent. It consists of methane, ethane, and propane.]  | H K                         | 272-882-7 | 68919-09-5 | Carc. Cat. 1; R45<br>Muta. Cat. 2; R46 | T<br>R: 45-46<br>S: 53-45 |                      |                               |
| 649-105-00-9 | Gases (petroleum), fluidized catalytic cracker splitter overheads<br>Petroleum gas<br>[A complex combination of hydrocarbons produced by the fractionation of the charge to the C <sub>3</sub> -C <sub>4</sub> splitter. It consists predominantly of C <sub>3</sub> hydrocarbons.]  | H K                         | 272-893-7 | 68919-20-0 | Carc. Cat. 1; R45<br>Muta. Cat. 2; R46 | T<br>R: 45-46<br>S: 53-45 |                      |                               |
| 649-106-00-4 | Gases (petroleum), straight-run stabilizer off<br>Petroleum gas<br>[A complex combination of hydrocarbons obtained from the fractionation of the liquid from the first tower used in the distillation of crude oil. It consists of saturated aliphatic hydrocarbons having carbon numbers predominantly in the range of C <sub>1</sub> through C <sub>4</sub> .] | H K                         | 272-883-2 | 68919-10-8 | Carc. Cat. 1; R45<br>Muta. Cat. 2; R46 | T<br>R: 45<br>S: 53-45    |                      |                               |



| Index No     | chemical name  | Notes related to substances | EC No     | CAS No     | Classification                         | Labelling                 | Concentration Limits | Notes related to preparations |
|--------------|--|-----------------------------|-----------|------------|--|---------------------------|----------------------|-------------------------------|
| 649-107-00-X | Gases (petroleum), catalytic cracked naphtha debutanizer<br>Petroleum gas<br>[A complex combination of hydrocarbons obtained from fractionation of catalytic cracked naphtha. It consists of hydrocarbons having carbon numbers predominantly in the range of C <sub>1</sub> through C <sub>4</sub> .]   | H K                         | 273-169-3 | 68952-76-1 | Carc. Cat. 1; R45<br>Muta. Cat. 2; R46 | T<br>R: 45-46<br>S: 53-45 |                      |                               |
| 649-108-00-5 | Tail gas (petroleum), catalytic cracked distillate and naphtha stabilizer<br>Petroleum gas<br>[A complex combination of hydrocarbons obtained by the fractionation of catalytic cracked naphtha and distillate. It consists predominantly of hydrocarbons having carbon numbers predominantly in the range of C <sub>1</sub> through C <sub>4</sub> .]             | H K                         | 273-170-9 | 68952-77-2 | Carc. Cat. 1; R45<br>Muta. Cat. 2; R46 | T<br>R: 45-46<br>S: 53-45 |                      |                               |
| 649-109-00-0 | Tail gas (petroleum), thermal-cracked distillate, gas oil and naphtha absorber<br>petroleum gas<br>[A complex combination of hydrocarbons obtained from the separation of thermal-cracked distillates, naphtha and gas oil. It consists predominantly of hydrocarbons having carbon numbers predominantly in the range of C <sub>1</sub> through C <sub>6</sub> .] | H K                         | 273-175-6 | 68952-81-8 | Carc. Cat. 1; R45<br>Muta. Cat. 2; R46 | T<br>R: 45-46<br>S: 53-45 |                      |                               |

| Index No     | chemical name   | Notes related to substances | EC No     | CAS No     | Classification                         | Labelling                 | Concentration Limits | Notes related to preparations |
|--------------|---|-----------------------------|-----------|------------|--|---------------------------|----------------------|-------------------------------|
| 649-110-00-6 | Tail gas (petroleum), thermal cracked hydrocarbon fractionation stabilizer, petroleum coking<br>Petroleum gas<br>[A complex combination of hydrocarbons obtained from the fractionation stabilization of thermal cracked hydrocarbons from petroleum coking process. It consists of hydrocarbons having carbon numbers predominantly in the range of C <sub>1</sub> through C <sub>6</sub> .]   | H K                         | 273-176-1 | 68952-82-9 | Carc. Cat. 1; R45<br>Muta. Cat. 2; R46 | T<br>R: 45-46<br>S: 53-45 |                      |                               |
| 649-111-00-1 | Gases (petroleum, light steam-cracked, butadiene conc.)<br>Petroleum gas<br>[A complex combination of hydrocarbons produced by the distillation of products from a thermal cracking process, It consists of hydrocarbons having a carbon number predominantly of C <sub>4</sub> .]  | H K                         | 273-265-5 | 68955-28-2 | Carc. Cat. 1; R45<br>Muta. Cat. 2; R46 | T<br>R: 45-46<br>S: 53-45 |                      |                               |
| 649-112-00-7 | Gases (petroleum), straight-run naphtha catalytic reformer stabilizer overhead<br>Petroleum gas<br>[A complex combination of hydrocarbons obtained by the catalytic reforming of straight-run naphtha and the fractionation of the total effluent. It consists of saturated aliphatic hydrocarbons having carbon numbers predominantly in the range of C <sub>2</sub> through C <sub>4</sub> .] | H K                         | 273-270-2 | 68955-34-0 | Carc. Cat. 1; R45<br>Muta. Cat. 2; R46 | T<br>R: 45-46<br>S: 53-45 |                      |                               |
| 649-113-00-2 | Hydrocarbons, C <sub>4</sub><br>Petroleum gas   | H K                         | 289-339-5 | 87741-01-3 | Carc. Cat. 1; R45<br>Muta. Cat. 2; R46 | T<br>R: 45-46<br>S: 53-45 |                      |                               |

| Index No     | chemical name   | Notes related to substances | EC No     | CAS No     | Classification                                    | Labelling                        | Concentration Limits | Notes related to preparations |
|--------------|---|-----------------------------|-----------|------------|---|----------------------------------|----------------------|-------------------------------|
| 649-114-00-8 | Alkanes, C <sub>1-4</sub> , C <sub>3</sub> -rich<br>Petroleum gas   | H K                         | 292-456-4 | 90622-55-2 | Carc. Cat. 1; R45<br>Muta. Cat. 2; R46            | T<br>R: 45-46<br>S: 53-45        |                      |                               |
| 649-115-00-3 | Gases (petroleum), steam-cracker<br>C <sub>3</sub> -rich<br>Petroleum gas<br>[A complex combination of hydrocarbons produced by the distillation of products from a steam cracking process. It consists predominantly of propylene with some propane and boils in the range of approximately -70 °C to 0 °C (-94 °F to 32 °F).]   | H K                         | 295-404-9 | 92045-22-2 | Carc. Cat. 1; R45<br>Muta. Cat. 2; R46            | T<br>R: 45-46<br>S: 53-45        |                      |                               |
| 649-116-00-9 | Hydrocarbons, C <sub>4</sub> , steam-cracker<br>distillate<br>Petroleum gas<br>[A complex combination of hydrocarbons produced by the distillation of the products of a steam cracking process. It consists predominantly of hydrocarbons having a carbon number of C <sub>4</sub> , predominantly 1-butene and 2-butene, containing also butane and isobutene and boiling in the range of approximately minus 12 °C to 5 °C (10.4 °F to 41 °F).] | H K                         | 295-405-4 | 92045-23-3 | Carc. Cat. 1; R45<br>Muta. Cat. 2; R46            | T<br>R: 45-46<br>S: 53-45        |                      |                               |
| 649-117-00-4 | Petroleum gases, liquefied,<br>sweetened, C <sub>4</sub> fraction<br>Petroleum gas<br>[A complex combination of hydrocarbons obtained by subjecting a liquified petroleum gas mix to a sweetening process to oxidize mercaptans or to remove acidic impurities. It consists predominantly of C <sub>4</sub> saturated and unsaturated hydrocarbons.]  | HKS                         | 295-463-0 | 92045-80-2 | F+; R12<br>Carc. Cat. 1; R45<br>Muta. Cat. 2; R46 | F+; T<br>R: 12-45-46<br>S: 53-45 |                      |                               |

| Index No     | chemical name  | Notes related to substances | EC No     | CAS No     | Classification                         | Labelling                 | Concentration Limits | Notes related to preparations |
|--------------|--|-----------------------------|-----------|------------|--|---------------------------|----------------------|-------------------------------|
| 649-119-00-5 | Raffinates (petroleum), steam-cracked C <sub>4</sub> fraction cuprous ammonium acetate extrn., C <sub>3,5</sub> and C <sub>3,5</sub> unsatd., butadiene-free Petroleum gas   | H K                         | 307-769-4 | 97722-19-5 | Carc. Cat. 1; R45<br>Muta. Cat. 2; R46 | T<br>R: 45-46<br>S: 53-45 |                      |                               |
| 649-120-00-0 | Gases (petroleum), amine system feed<br>Refinery gas<br>[The feed gas to the amine system for removal of hydrogen sulfide. It consists of hydrogen. Carbon monoxide, carbon dioxide, hydrogen sulfide and aliphatic hydrocarbons having carbon numbers predominantly in the range of C <sub>1</sub> through C <sub>5</sub> may also be present.] | H K                         | 270-746-1 | 68477-65-6 | Carc. Cat. 1; R45<br>Muta. Cat. 2; R46 | T<br>R: 45-46<br>S: 53-45 |                      |                               |
| 649-121-00-6 | Gases (petroleum), benzene unit hydrodesulfurizer off<br>Refinery gas<br>[Off gases produced by the benzene unit. It consists primarily of hydrogen. Carbon monoxide and hydrocarbons having carbon numbers predominantly in the range of C <sub>1</sub> through C <sub>6</sub> , including benzene, may also be present.]                       | H K                         | 270-747-7 | 68477-66-7 | Carc. Cat. 1; R45<br>Muta. Cat. 2; R46 | T<br>R: 45-46<br>S: 53-45 |                      |                               |

| Index No     | chemical name   | Notes related to substances | EC No     | CAS No     | Classification                         | Labelling                 | Concentration Limits | Notes related to preparations |
|--------------|---|-----------------------------|-----------|------------|--|---------------------------|----------------------|-------------------------------|
| 649-122-00-1 | Gases (petroleum), benzene unit recycle, hydrogen-rich<br>Refinery gas<br>[A complex combination of hydrocarbons obtained by recycling the gases of the benzene unit. It consists primarily of hydrogen with various small amounts of carbon monoxide and hydrocarbons having carbon numbers in the range of C <sub>1</sub> through C <sub>6</sub> .]   | H K                         | 270-748-2 | 68477-67-8 | Carc. Cat. 1; R45<br>Muta. Cat. 2; R46 | T<br>R: 45-46<br>S: 53-45 |                      |                               |
| 649-123-00-7 | Gases (petroleum), blend oil, hydrogen-nitrogen-rich<br>Refinery gas<br>[A complex combination of hydrocarbons obtained by distillation of a blend oil. It consists primarily of hydrogen and nitrogen with various small amounts of carbon monoxide, carbon dioxide, and aliphatic hydrocarbons having carbon numbers predominantly in the range of C <sub>1</sub> through C <sub>5</sub> .] | H K                         | 270-749-8 | 68477-68-9 | Carc. Cat. 1; R45<br>Muta. Cat. 2; R46 | T<br>R: 45-46<br>S: 53-45 |                      |                               |
| 649-124-00-2 | Gases (petroleum), catalytic reformed naphtha stripper overheads<br>Refinery gas<br>[A complex combination of hydrocarbons obtained from stabilization of catalytic reformed naphtha. Its consists of hydrogen and saturated hydrocarbons having carbon numbers predominantly in the range of C <sub>1</sub> through C <sub>4</sub> .]  | H K                         | 270-759-2 | 68477-77-0 | Carc. Cat. 1; R45<br>Muta. Cat. 2; R46 | T<br>R: 45-46<br>S: 53-45 |                      |                               |

| Index No     | chemical name   | Notes related to substances | EC No     | CAS No     | Classification                         | Labelling                 | Concentration Limits | Notes related to preparations |
|--------------|---|-----------------------------|-----------|------------|--|---------------------------|----------------------|-------------------------------|
| 649-125-00-8 | Gases (petroleum), C <sub>6-8</sub> catalytic reformer recycle<br>Refinery gas<br>[A complex combination of hydrocarbons produced by distillation of products from catalytic reforming of C <sub>6</sub> -C <sub>8</sub> feed and recycled to conserve hydrogen. It consists primarily of hydrogen. It may also contain various small amounts of carbon monoxide, carbon dioxide, nitrogen, and hydrocarbons having carbon numbers predominantly in the range of C <sub>1</sub> through C <sub>6</sub> .] | H K                         | 270-761-3 | 68477-80-5 | Carc. Cat. 1; R45<br>Muta. Cat. 2; R46 | T<br>R: 45-46<br>S: 53-45 |                      |                               |
| 649-126-00-3 | Gases (petroleum), C <sub>6-8</sub> catalytic reformer<br>Refinery gas<br>[A complex combination of hydrocarbons produced by distillation of products from catalytic reforming of C <sub>6</sub> -C <sub>8</sub> feed. It consists of hydrocarbons having carbon numbers in the range of C <sub>1</sub> through C <sub>5</sub> and hydrogen.]   | H K                         | 270-762-9 | 68477-81-6 | Carc. Cat. 1; R45<br>Muta. Cat. 2; R46 | T<br>R: 45-46<br>S: 53-45 |                      |                               |
| 649-127-00-9 | Gases (petroleum), C <sub>6-8</sub> catalytic reformer recycle, hydrogen-rich<br>Refinery gas   | H K                         | 270-763-4 | 68477-82-7 | Carc. Cat. 1; R45<br>Muta. Cat. 2; R46 | T<br>R: 45-46<br>S: 53-45 |                      |                               |

| Index No     | chemical name  | Notes related to substances | EC No     | CAS No     | Classification                         | Labelling                 | Concentration Limits | Notes related to preparations |
|--------------|--|-----------------------------|-----------|------------|--|---------------------------|----------------------|-------------------------------|
| 649-128-00-4 | Gases (petroleum), C <sub>2</sub> -return stream<br>Refinery gas<br>[A complex combination of hydrocarbons obtained by the extraction of hydrogen from a gas stream which consists primarily of hydrogen with small amounts of nitrogen, carbon monoxide, methane, ethane, and ethylene. It contains predominantly hydrocarbons such as methane, ethane, and ethylene with small amounts of hydrogen, nitrogen and carbon monoxide.] | H K                         | 270-766-0 | 68477-84-9 | Carc. Cat. 1; R45<br>Muta. Cat. 2; R46 | T<br>R: 45-46<br>S: 53-45 |                      |                               |
| 649-129-00-X | Gases (petroleum), dry sour, gas-concn.-unit-off<br>Refinery gas<br>[The complex combination of dry gases from a gas concentration unit. It consists of hydrogen, hydrogen sulfide and hydrocarbons having carbon numbers predominantly in the range of C <sub>1</sub> through C <sub>3</sub> .]   | H K                         | 270-774-4 | 68477-92-9 | Carc. Cat. 1; R45<br>Muta. Cat. 2; R46 | T<br>R: 45-46<br>S: 53-45 |                      |                               |
| 649-130-00-5 | Gases (petroleum), gas concn. reabsorber distn.<br>Refinery gas<br>[A complex combination of hydrocarbons produced by distillation of products from combined gas streams in a gas concentration reabsorber. It consists predominantly of hydrogen, carbon monoxide, carbon dioxide, nitrogen, hydrogen sulfide and hydrocarbons having carbon numbers in the range of C <sub>1</sub> through C <sub>3</sub> .]                       | H K                         | 270-776-5 | 68477-93-0 | Carc. Cat. 1; R45<br>Muta. Cat. 2; R46 | T<br>R: 45-46<br>S: 53-45 |                      |                               |

| Index No     | chemical name   | Notes related to substances | EC No     | CAS No     | Classification                         | Labelling                 | Concentration Limits | Notes related to preparations |
|--------------|---|-----------------------------|-----------|------------|--|---------------------------|----------------------|-------------------------------|
| 649-131-00-0 | Gases (petroleum), hydrogen absorber off<br>Refinery gas<br>[A complex combination obtained by absorbing hydrogen from a hydrogen rich stream. It consists of hydrogen, carbon monoxide, nitrogen, and methane with small amounts of C <sub>2</sub> hydrocarbons.]  | H K                         | 270-779-1 | 68477-96-3 | Carc. Cat. 1; R45<br>Muta. Cat. 2; R46 | T<br>R: 45-46<br>S: 53-45 |                      |                               |
| 649-132-00-6 | Gases (petroleum), hydrogen-rich<br>Refinery gas<br>[A complex combination separated as a gas from hydrocarbon gases by chilling. It consists primarily of hydrogen with various small amounts of carbon monoxide, nitrogen, methane, and C <sub>2</sub> hydrocarbons.]   | H K                         | 270-780-7 | 68477-97-4 | Carc. Cat. 1; R45<br>Muta. Cat. 2; R46 | T<br>R: 45-46<br>S: 53-45 |                      |                               |
| 649-133-00-1 | Gases (petroleum), hydrotreater blend oil recycle, hydrogen-nitrogen-rich<br>Refinery gas<br>[A complex combination obtained from recycled hydrotreated blend oil. It consists primarily of hydrogen and nitrogen with various small amounts of carbon monoxide, carbon dioxide and hydrocarbons having carbon numbers predominantly in the range of C <sub>1</sub> through C <sub>5</sub> .] | H K                         | 270-781-2 | 68477-98-5 | Carc. Cat. 1; R45<br>Muta. Cat. 2; R46 | T<br>R: 45-46<br>S: 53-45 |                      |                               |



| Index No     | chemical name  | Notes related to substances | EC No     | CAS No     | Classification                         | Labelling                 | Concentration Limits | Notes related to preparations |
|--------------|--|-----------------------------|-----------|------------|--|---------------------------|----------------------|-------------------------------|
| 649-134-00-7 | Gases (petroleum), recycle, hydrogen-rich<br>Refinery gas<br>[A complex combination obtained from recycled reactor gases. It consists primarily of hydrogen with various small amounts of carbon monoxide, carbon dioxide, nitrogen, hydrogen sulfide, and saturated aliphatic hydrocarbons having carbon numbers in the range of C <sub>1</sub> through C <sub>5</sub> .] | H K                         | 270-783-3 | 68478-00-2 | Carc. Cat. 1; R45<br>Muta. Cat. 2; R46 | T<br>R: 45-46<br>S: 53-45 |                      |                               |
| 649-135-00-2 | Gases (petroleum), reformer make-up, hydrogen-rich<br>Refinery gas<br>[A complex combination obtained from the reformers. It consists primarily of hydrogen with various small amounts of carbon monoxide and aliphatic hydrocarbons having carbon numbers predominantly in the range of C <sub>1</sub> through C <sub>5</sub> .]  | H K                         | 270-784-9 | 68478-01-3 | Carc. Cat. 1; R45<br>Muta. Cat. 2; R46 | T<br>R: 45-46<br>S: 53-45 |                      |                               |
| 649-136-00-8 | Gases (petroleum), reforming hydrotreater<br>Refinery gas<br>[A complex combination obtained from the reforming hydrotreating process. It consists primarily of hydrogen, methane, and ethane with various small amounts of hydrogen sulfide and aliphatic hydrocarbons having carbon numbers predominantly in the range of C <sub>3</sub> through C <sub>5</sub> .]       | H K                         | 270-785-4 | 68478-02-4 | Carc. Cat. 1; R45<br>Muta. Cat. 2; R46 | T<br>R: 45-46<br>S: 53-45 |                      |                               |

| Index No     | chemical name   | Notes related to substances | EC No     | CAS No     | Classification                         | Labelling                 | Concentration Limits | Notes related to preparations |
|--------------|---|-----------------------------|-----------|------------|--|---------------------------|----------------------|-------------------------------|
| 649-137-00-3 | Gases (petroleum), reforming hydrotreater, hydrogen-methane-rich<br>Refinery gas<br>[A complex combination obtained from the reforming hydrotreating process. It consists primarily of hydrogen and methane with various small amounts of carbon monoxide, carbon dioxide, nitrogen and saturated aliphatic hydrocarbons having carbon numbers predominantly in the range of C <sub>2</sub> through C <sub>5</sub> .] | H K                         | 270-787-5 | 68478-03-5 | Carc. Cat. 1; R45<br>Muta. Cat. 2; R46 | T<br>R: 45-46<br>S: 53-45 |                      |                               |
| 649-138-00-9 | Gases (petroleum), reforming hydrotreater make-up, hydrogen-rich<br>Refinery gas<br>[A complex combination obtained from the reforming hydrotreating process. It consists primarily of hydrogen with various small amounts of carbon monoxide and aliphatic hydrocarbons having carbon numbers predominantly in the range of C <sub>1</sub> through C <sub>5</sub> .]   | H K                         | 270-788-0 | 68478-04-6 | Carc. Cat. 1; R45<br>Muta. Cat. 2; R46 | T<br>R: 45-46<br>S: 53-45 |                      |                               |
| 649-139-00-4 | Gases (petroleum), thermal cracking distn.<br>Refinery gas<br>[A complex combination produced by distillation of products from a thermal cracking process. It consists of hydrogen, hydrogen sulfide, carbon monoxide, carbon dioxide and hydrocarbons having carbon numbers predominantly in the range of C <sub>1</sub> through C <sub>6</sub> .]   | H K                         | 270-789-6 | 68478-05-7 | Carc. Cat. 1; R45<br>Muta. Cat. 2; R46 | T<br>R: 45-46<br>S: 53-45 |                      |                               |

| Index No     | chemical name   | Notes related to substances | EC No     | CAS No     | Classification                         | Labelling                 | Concentration Limits | Notes related to preparations |
|--------------|---|-----------------------------|-----------|------------|--|---------------------------|----------------------|-------------------------------|
| 649-140-00-X | Tail gas (petroleum), catalytic cracker refractation absorber<br>Refinery gas<br>[A complex combination of hydrocarbons obtained from refractation of products from a catalytic cracking process. It consists of hydrogen and hydrocarbons having carbon numbers predominantly in the range of C <sub>1</sub> through C <sub>3</sub> .] | H K                         | 270-805-1 | 68478-25-1 | Carc. Cat. 1; R45<br>Muta. Cat. 2; R46 | T<br>R: 45-46<br>S: 53-45 |                      |                               |
| 649-141-00-5 | Tail gas (petroleum), catalytic reformed naphtha separator<br>Refinery gas<br>[A complex combination of hydrocarbons obtained from the catalytic reforming of straight run naphtha. It consists of hydrogen and hydrocarbons having carbon numbers predominantly in the range of C <sub>1</sub> through C <sub>6</sub> .]               | H K                         | 270-807-2 | 68478-27-3 | Carc. Cat. 1; R45<br>Muta. Cat. 2; R46 | T<br>R: 45-46<br>S: 53-45 |                      |                               |
| 649-142-00-0 | Tail gas (petroleum), catalytic reformed naphtha stabilizer<br>Refinery gas<br>[A complex combination of hydrocarbons obtained from the stabilization of catalytic reformed naphtha. It consists of hydrogen and hydrocarbons having carbon numbers predominantly in the range of C <sub>1</sub> through C <sub>6</sub> .]              | H K                         | 270-808-8 | 68478-28-4 | Carc. Cat. 1; R45<br>Muta. Cat. 2; R46 | T<br>R: 45-46<br>S: 53-45 |                      |                               |

| Index No     | chemical name   | Notes related to substances | EC No     | CAS No     | Classification                         | Labelling                 | Concentration Limits | Notes related to preparations |
|--------------|---|-----------------------------|-----------|------------|--|---------------------------|----------------------|-------------------------------|
| 649-143-00-6 | Tail gas (petroleum), cracked distillate hydrotreater separator<br>Refinery gas<br>[A complex combination of hydrocarbons obtained by treating cracked distillates with hydrogen in the presence of a catalyst. It consists of hydrogen and saturated aliphatic hydrocarbons having carbon numbers predominantly in the range of C <sub>1</sub> through C <sub>5</sub> .] | H K                         | 270-809-3 | 68478-29-5 | Carc. Cat. 1; R45<br>Muta. Cat. 2; R46 | T<br>R: 45-46<br>S: 53-45 |                      |                               |
| 649-144-00-1 | Tail gas (petroleum), hydrodesulfurized straight-run naphtha separator<br>Refinery gas<br>[A complex combination of hydrocarbons obtained from hydrodesulfurization of straight-run naphtha. It consists of hydrogen and saturated aliphatic hydrocarbons having carbon numbers predominantly in the range of C <sub>1</sub> through C <sub>6</sub> .]                    | H K                         | 270-810-9 | 68478-30-8 | Carc. Cat. 1; R45<br>Muta. Cat. 2; R46 | T<br>R: 45-46<br>S: 53-45 |                      |                               |
| 649-145-00-7 | Gases (petroleum), catalytic reformed straight-run naphtha stabilizer overheads<br>Refinery gas<br>[A complex combination of hydrocarbons obtained from the catalytic reforming of straight-run naphtha followed by fractionation of the total effluent. It consists of hydrogen, methane, ethane and propane.]   | H K                         | 270-999-8 | 68513-14-4 | Carc. Cat. 1; R45<br>Muta. Cat. 2; R46 | T<br>R: 45-46<br>S: 53-45 |                      |                               |

| Index No     | chemical name  | Notes related to substances | EC No     | CAS No     | Classification                         | Labelling                 | Concentration Limits | Notes related to preparations |
|--------------|--|-----------------------------|-----------|------------|--|---------------------------|----------------------|-------------------------------|
| 649-146-00-2 | Gases (petroleum), reformer effluent high-pressure flash drum off<br>Refinery gas<br>[A complex combination produced by the high-pressure flashing of the effluent from the reforming reactor. It consists primarily of hydrogen with various small amounts of methane, ethane, and propane.]  | H K                         | 271-003-4 | 68513-18-8 | Carc. Cat. 1; R45<br>Muta. Cat. 2; R46 | T<br>R: 45-46<br>S: 53-45 |                      |                               |
| 649-147-00-8 | Gases (petroleum), reformer effluent low-pressure flash drum off<br>Refinery gas<br>[A complex combination produced by low-pressure flashing of the effluent from the reforming reactor. It consists primarily of hydrogen with various small amounts of methane, ethane, and propane.]  | H K                         | 271-005-5 | 68513-19-9 | Carc. Cat. 1; R45<br>Muta. Cat. 2; R46 | T<br>R: 45-46<br>S: 53-45 |                      |                               |
| 649-148-00-3 | Gases (petroleum), oil refinery gas distn. off<br>Refinery gas<br>[A complex combination separated by distillation of a gas stream containing hydrogen, carbon monoxide, carbon dioxide and hydrocarbons having carbon numbers in the range of C <sub>1</sub> through C <sub>6</sub> or obtained by cracking ethane and propane. It consists of hydrocarbons having carbon numbers predominantly in the range of C <sub>1</sub> through C <sub>2</sub> , hydrogen, nitrogen, and carbon monoxide.] | H K                         | 271-258-1 | 68527-15-1 | Carc. Cat. 1; R45<br>Muta. Cat. 2; R46 | T<br>R: 45-46<br>S: 53-45 |                      |                               |

| Index No     | chemical name   | Notes related to substances | EC No     | CAS No     | Classification                         | Labelling                 | Concentration Limits | Notes related to preparations |
|--------------|---|-----------------------------|-----------|------------|--|---------------------------|----------------------|-------------------------------|
| 649-149-00-9 | Gases (petroleum), benzene unit hydrotreater depentanizer overheads<br>Refinery gas<br>[A complex combination produced by treating the feed from the benzene unit with hydrogen in the presence of a catalyst followed by depentanizing. It consists primarily of hydrogen, ethane and propane with various small amounts of nitrogen, carbon monoxide, carbon dioxide and hydrocarbons having carbon numbers predominantly in the range of C <sub>1</sub> through C <sub>6</sub> . It may contain trace amounts of benzene.] | H K                         | 271-623-5 | 68602-82-4 | Carc. Cat. 1; R45<br>Muta. Cat. 2; R46 | T<br>R: 45-46<br>S: 53-45 |                      |                               |
| 649-150-00-4 | Gases (petroleum), secondary absorber off, fluidized catalytic cracker overheads fractionator<br>Refinery gas<br>[A complex combination produced by the fractionation of the overhead products from the catalytic cracking process in the fluidized catalytic cracker. It consists of hydrogen, nitrogen, and hydrocarbons having carbon numbers predominantly in the range of C <sub>1</sub> through C <sub>3</sub> .]   | H K                         | 271-625-6 | 68602-84-6 | Carc. Cat. 1; R45<br>Muta. Cat. 2; R46 | T<br>R: 45-46<br>S: 53-45 |                      |                               |

| Index No     | chemical name  | Notes related to substances | EC No     | CAS No     | Classification                         | Labelling                 | Concentration Limits | Notes related to preparations |
|--------------|--|-----------------------------|-----------|------------|--|---------------------------|----------------------|-------------------------------|
| 649-151-00-X | Petroleum products, refinery gases<br>Refinery gas<br>[A complex combination which consists primarily of hydrogen with various small amounts of methane, ethane, and propane.]   | H K                         | 271-750-6 | 68607-11-4 | Car. Cat. 1; R45<br>Muta. Cat. 2; R46  | T<br>R: 45-46<br>S: 53-45 |                      |                               |
| 649-152-00-5 | Gases (petroleum), hydrocracking low-pressure separator<br>Refinery gas<br>[A complex combination obtained by the liquid-vapor separation of the hydrocracking process reactor effluent. It consists predominantly of hydrogen and saturated hydrocarbons having carbon numbers predominantly in the range of C <sub>1</sub> through C <sub>3</sub> .] | H K                         | 272-182-1 | 68783-06-2 | Carc. Cat. 1; R45<br>Muta. Cat. 2; R46 | T<br>R: 45-46<br>S: 53-45 |                      |                               |
| 649-153-00-0 | Gases (petroleum), refinery<br>Refinery gas<br>[A complex combination obtained from various petroleum refining operations. It consists of hydrogen and hydrocarbons having carbon numbers predominantly in the range of C <sub>1</sub> through C <sub>3</sub> .]   | H K                         | 272-338-9 | 68814-67-5 | Carc. Cat. 1; R45<br>Muta. Cat. 2; R46 | T<br>R: 45-46<br>S: 53-45 |                      |                               |
| 649-154-00-6 | Gases (petroleum), platformer products separator off<br>Refinery gas<br>[A complex combination obtained from the chemical reforming of naphthenes to aromatics. It consists of hydrogen and saturated aliphatic hydrocarbons having carbon numbers predominantly in the range of C <sub>2</sub> through C <sub>4</sub> .]                              | H K                         | 272-343-6 | 68814-90-4 | Carc. Cat. 1; R45<br>Muta. Cat. 2; R46 | T<br>R: 45-46<br>S: 53-45 |                      |                               |

| Index No     | chemical name  | Notes related to substances | EC No     | CAS No     | Classification                         | Labelling                 | Concentration Limits | Notes related to preparations |
|--------------|--|-----------------------------|-----------|------------|--|---------------------------|----------------------|-------------------------------|
| 649-155-00-1 | Gases (petroleum), hydrotreated sour kerosine depentanizer stabilizer off<br>Refinery gas<br>[The complex combination obtained from the depentanizer stabilization of hydrotreated kerosine. It consists primarily of hydrogen, methane, ethane, and propane with various small amounts of nitrogen, hydrogen sulfide, carbon monoxide and hydrocarbons having carbon numbers predominantly in the range of C <sub>4</sub> through C <sub>5</sub> .] | H K                         | 272-775-5 | 68911-58-0 | Carc. Cat. 1; R45<br>Muta. Cat. 2; R46 | T<br>R: 45-46<br>S: 53-45 |                      |                               |
| 649-156-00-7 | Gases (petroleum), hydrotreated sour kerosine flash drum<br>Refinery gas<br>[A complex combination obtained from the flash drum of the unit treating sour kerosine with hydrogen in the presence of a catalyst. It consists primarily of hydrogen and methane with various small amounts of nitrogen, carbon monoxide, and hydro-carbons having carbon numbers predominantly in the range of C <sub>2</sub> through C <sub>5</sub> .]                | H K                         | 272-776-0 | 68911-59-1 | Carc. Cat. 1; R45<br>Muta. Cat. 2; R46 | T<br>R: 45-46<br>S: 53-45 |                      |                               |
| 649-157-00-2 | Gases (petroleum), distillate unifier desulfurization stripper off<br>Refinery gas<br>[A complex combination stripped from the liquid product of the unifier desulfurization process. It consists of hydrogen sulfide, methane, ethane, and propane.]  | H K                         | 272-873-8 | 68919-01-7 | Carc. Cat. 1; R45<br>Muta. Cat. 2; R46 | T<br>R: 45-46<br>S: 53-45 |                      |                               |



| Index No     | chemical name  | Notes related to substances | EC No     | CAS No     | Classification                         | Labelling                 | Concentration Limits | Notes related to preparations |
|--------------|--|-----------------------------|-----------|------------|--|---------------------------|----------------------|-------------------------------|
| 649-158-00-8 | Gases (petroleum), fluidized catalytic cracker fractionation off Refinery gas<br>[A complex combination produced by the fractionation of the overhead product of the fluidized catalytic cracking process. It consists of hydrogen, hydrogen sulfide, nitrogen, and hydrocarbons having carbon numbers predominantly in the range of C <sub>1</sub> through C <sub>5</sub> .]                    | H K                         | 272-874-3 | 68919-02-8 | Carc. Cat. 1; R45<br>Muta. Cat. 2; R46 | T<br>R: 45-46<br>S: 53-45 |                      |                               |
| 649-159-00-3 | Gases (petroleum), fluidized catalytic cracker scrubbing secondary absorber off Refinery gas<br>[A complex combination produced by scrubbing the overhead gas from the fluidized catalytic cracker. It consists of hydrogen, nitrogen, methane, ethane and propane.]   | H K                         | 272-875-9 | 68919-03-9 | Carc. Cat. 1; R45<br>Muta. Cat. 2; R46 | T<br>R: 45-46<br>S: 53-45 |                      |                               |
| 649-160-00-9 | Gases (petroleum), heavy distillate hydrotreater desulfurization stripper off Refinery gas<br>[A complex combination stripped from the liquid product of the heavy distillate hydrotreater desulfurization process. It consists of hydrogen, hydrogen sulfide, and saturated aliphatic hydrocarbons having carbon numbers predominantly in the range of C <sub>1</sub> through C <sub>5</sub> .] | H K                         | 272-876-4 | 68919-04-0 | Carc. Cat. 1; R45<br>Muta. Cat. 2; R46 | T<br>R: 45-46<br>S: 53-45 |                      |                               |

| Index No     | chemical name  | Notes related to substances | EC No     | CAS No     | Classification                         | Labelling                 | Concentration Limits | Notes related to preparations |
|--------------|--|-----------------------------|-----------|------------|--|---------------------------|----------------------|-------------------------------|
| 649-161-00-4 | Gases (petroleum), platformer stabilizer off, light ends fractionation<br>Refinery gas<br>[A complex combination obtained by the fractionation of the light ends of the platinum reactors of the plattform unit. It consists of hydrogen, methane, ethane and propane.]  | H K                         | 272-880-6 | 68919-07-3 | Carc. Cat. 1; R45<br>Muta. Cat. 2; R46 | T<br>R: 45-46<br>S: 53-45 |                      |                               |
| 649-162-00-X | Gases (petroleum), preflash tower off, crude distn.<br>Refinery gas<br>[A complex combination produced from the first tower used in the distillation of crude oil. It consists of nitrogen and saturated aliphatic hydrocarbons having carbon numbers predominantly in the range of C <sub>1</sub> through C <sub>5</sub> .] | H K                         | 272-881-1 | 68919-08-4 | Carc. Cat. 1; R45<br>Muta. Cat. 2; R46 | T<br>R: 45-46<br>S: 53-45 |                      |                               |
| 649-163-00-5 | Gases (petroleum), tar stripper off<br>Refinery gas<br>[A complex combination obtained by the fractionation of reduced crude oil. It consists of hydrogen and hydrocarbons having carbon numbers predominantly in the range of C <sub>1</sub> through C <sub>4</sub> .]  | H K                         | 272-884-8 | 68919-11-9 | Carc. Cat. 1; R45<br>Muta. Cat. 2; R46 | T<br>R: 45-46<br>S: 53-45 |                      |                               |

| Index No     | chemical name  | Notes related to substances | EC No     | CAS No     | Classification                         | Labelling                 | Concentration Limits | Notes related to preparations |
|--------------|--|-----------------------------|-----------|------------|--|---------------------------|----------------------|-------------------------------|
| 649-164-00-0 | Gases (petroleum), unifier stripper off<br>Refinery gas<br>[A combination of hydrogen and methane obtained by fractionation of the products from the unifier unit.]  | H K                         | 272-885-3 | 68919-12-0 | Carc. Cat. 1; R45<br>Muta. Cat. 2; R46 | T<br>R: 45-46<br>S: 53-45 |                      |                               |
| 649-165-00-6 | Tail gas (petroleum), catalytic hydrodesulfurized naphtha separator<br>Refinery gas<br>[A complex combination of hydrocarbons obtained from the hydrodesulfurization of naphtha. It consists of hydrogen, methane, ethane, and propane.]   | H K                         | 273-173-5 | 68952-79-4 | Carc. Cat. 1; R45<br>Muta. Cat. 2; R46 | T<br>R: 45-46<br>S: 53-45 |                      |                               |
| 649-166-00-1 | Tail gas (petroleum), straight-run naphtha hydrodesulfurizer<br>Refinery gas<br>[A complex combination obtained from the hydrodesulfurization of straight-run naphtha. It consists of hydrogen and hydrocarbons having carbon numbers predominantly in the range of C <sub>1</sub> through C <sub>5</sub> .] | H K                         | 273-174-0 | 68952-80-7 | Carc. Cat. 1; R45<br>Muta. Cat. 2; R46 | T<br>R: 45-46<br>S: 53-45 |                      |                               |

| Index No     | chemical name  | Notes related to substances | EC No     | CAS No     | Classification                         | Labelling                 | Concentration Limits | Notes related to preparations |
|--------------|--|-----------------------------|-----------|------------|--|---------------------------|----------------------|-------------------------------|
| 649-167-00-7 | Gases (petroleum), sponge absorber off, fluidized catalytic cracker and gas oil desulfurizer overhead fractionation<br>Refinery gas<br>[A complex combination obtained by the fractionation of products from the fluidized catalytic cracker and gas oil desulfurizer. It consists of hydrogen and hydrocarbons having carbon numbers predominantly in the range of C <sub>1</sub> through C <sub>4</sub> .] | H K                         | 273-269-7 | 68955-33-9 | Carc. Cat. 1; R45<br>Muta. Cat. 2; R46 | T<br>R: 45-46<br>S: 53-45 |                      |                               |
| 649-168-00-2 | Gases (petroleum), crude distn. and catalytic cracking<br>Refinery gas<br>[A complex combination produced by crude distillation and catalytic cracking processes. It consists of hydrogen, hydrogen sulfide, nitrogen, carbon monoxide and paraffinic and olefinic hydrocarbons having carbon numbers predominantly in the range of C <sub>1</sub> through C <sub>6</sub> .]                                 | H K                         | 273-563-5 | 68989-88-8 | Carc. Cat. 1; R45<br>Muta. Cat. 2; R46 | T<br>R: 45-46<br>S: 53-45 |                      |                               |
| 649-169-00-8 | Gases (petroleum), gas oil diethanolamine scrubber off<br>Refinery gas<br>[A complex combination produced by desulfurization of gas oils with diethanolamine. It consists predominantly of hydrogen sulfide, hydrogen and aliphatic hydrocarbons having carbon numbers in the range of C <sub>1</sub> through C <sub>5</sub> .]  | H K                         | 295-397-2 | 92045-15-3 | Carc. Cat. 1; R45<br>Muta. Cat. 2; R46 | T<br>R: 45-46<br>S: 53-45 |                      |                               |

| Index No     | chemical name  | Notes related to substances | EC No     | CAS No     | Classification                         | Labelling                 | Concentration Limits | Notes related to preparations |
|--------------|--|-----------------------------|-----------|------------|--|---------------------------|----------------------|-------------------------------|
| 649-170-00-3 | Gases (petroleum), gas oil hydrodesulfurization effluent<br>Refinery gas<br>[A complex combination obtained by separation of the liquid phase from the effluent from the hydrogenation reaction. It consists predominantly of hydrogen, hydrogen sulfide and aliphatic hydrocarbons having carbon numbers predominantly in the range of C <sub>1</sub> through C <sub>3</sub> .] | H K                         | 295-398-8 | 92045-16-4 | Carc. Cat. 1; R45<br>Muta. Cat. 2; R46 | T<br>R: 45-46<br>S: 53-45 |                      |                               |
| 649-171-00-9 | Gases (petroleum), gas oil hydrodesulfurization purge<br>Refinery gas<br>[A complex combination of gases obtained from the reformer and from the purges from the hydrogenation reactor. It consists predominantly of hydrogen and aliphatic hydrocarbons having carbon numbers predominantly in the range of C <sub>1</sub> through C <sub>4</sub> .]                            | H K                         | 295-399-3 | 92045-17-5 | Carc. Cat. 1; R45<br>Muta. Cat. 2; R46 | T<br>R: 45-46<br>S: 53-45 |                      |                               |
| 649-172-00-4 | Gases (petroleum), hydrogenator effluent flash drum off<br>Refinery gas<br>[A complex combination of gases obtained from flash of the effluents after the hydrogenation reaction. It consists predominantly of hydrogen and aliphatic hydrocarbons having carbon numbers predominantly in the range of C <sub>1</sub> through C <sub>6</sub> .]                                  | H K                         | 295-400-7 | 92045-18-6 | Carc. Cat. 1; R45<br>Muta. Cat. 2; R46 | T<br>R: 45-46<br>S: 53-45 |                      |                               |

| Index No     | chemical name   | Notes related to substances | EC No     | CAS No     | Classification                         | Labelling                 | Concentration Limits | Notes related to preparations |
|--------------|---|-----------------------------|-----------|------------|--|---------------------------|----------------------|-------------------------------|
| 649-173-00-X | Gases (petroleum), naphtha steam cracking high-pressure residual<br>Refinery gas<br>[A complex combination obtained as a mixture of the non-condensable portions from the product of a naphtha steam cracking process as well as residual gases obtained during the preparation of subsequent products. It consists predominantly of hydrogen and paraffinic and olefinic hydrocarbons having carbon numbers predominantly in the range of C <sub>1</sub> through C <sub>5</sub> with which natural gas may also be mixed.] | H K                         | 295-401-2 | 92045-19-7 | Carc. Cat. 1; R45<br>Muta. Cat. 2; R46 | T<br>R: 45-46<br>S: 53-45 |                      |                               |
| 649-174-00-5 | Gases (petroleum), residue visbaking off<br>Refinery gas<br>[A complex combination obtained from viscosity reduction of residues in a furnace. It consists predominantly of hydrogen sulfide and paraffinic and olefinic hydrocarbons having carbon numbers predominantly in the range of C <sub>1</sub> through C <sub>5</sub> .]  | H K                         | 295-402-8 | 92045-20-0 | Carc. Cat. 1; R45<br>Muta. Cat. 2; R46 | T<br>R: 45-46<br>S: 53-45 |                      |                               |
| 649-177-00-1 | Gases (petroleum), C <sub>3,4</sub><br>Petroleum gas<br>[A complex combination of hydrocarbons produced by distillation of products from the cracking of crude oil. It consists of hydrocarbons having carbon numbers in the range of C <sub>3</sub> through C <sub>4</sub> , predominantly of propane and propylene, and boiling in the range of approximately -51 °C to -1 °C (-60 °F to 30 °F).]   | H K                         | 268-629-5 | 68131-75-9 | Carc. Cat. 1; R45<br>Muta. Cat. 2; R46 | T<br>R: 45-46<br>S: 53-45 |                      |                               |

| Index No     | chemical name   | Notes related to substances | EC No     | CAS No     | Classification                         | Labelling                 | Concentration Limits | Notes related to preparations |
|--------------|---|-----------------------------|-----------|------------|--|---------------------------|----------------------|-------------------------------|
| 649-178-00-7 | Tail gas (petroleum), catalytic cracked distillate and catalytic cracked naphtha fractionation absorber<br>Petroleum gas<br>[The complex combination of hydrocarbons from the distillation of the products from catalytic cracked distillates and catalytic cracked naphtha. It consists predominantly of hydrocarbons having carbon numbers in the range of C <sub>1</sub> through C <sub>4</sub> .] | H K                         | 269-617-2 | 68307-98-2 | Carc. Cat. 1; R45<br>Muta. Cat. 2; R46 | T<br>R: 45-46<br>S: 53-45 |                      |                               |
| 649-179-00-2 | Tail gas (petroleum), catalytic polymn. naphtha fractionation stabilizer<br>Petroleum gas<br>[A complex combination of hydrocarbons from the fractionation stabilization products from polymerization of naphtha. It consists predominantly of hydrocarbons having carbon numbers in the range of C <sub>1</sub> through C <sub>4</sub> .]  | H K                         | 269-618-8 | 68307-99-3 | Carc. Cat. 1; R45<br>Muta. Cat. 2; R46 | T<br>R: 45-46<br>S: 53-45 |                      |                               |

| Index No     | chemical name  | Notes related to substances | EC No     | CAS No     | Classification                         | Labelling                 | Concentration Limits | Notes related to preparations |
|--------------|--|-----------------------------|-----------|------------|--|---------------------------|----------------------|-------------------------------|
| 649-180-00-8 | Tail gas (petroleum), catalytic reformed naphtha fractionation stabilizer, hydrogen sulfide-free Petroleum gas<br>[A complex combination of hydrocarbons obtained from fractionation stabilization of catalytic reformed naphtha and from which hydrogen sulfide has been removed by amine treatment. It consists predominantly of hydrocarbons having carbon numbers predominantly in the range of C <sub>1</sub> through C <sub>4</sub> .] | H K                         | 269-619-3 | 68308-00-9 | Carc. Cat. 1; R45<br>Muta. Cat. 2; R46 | T<br>R: 45-46<br>S: 53-45 |                      |                               |
| 649-181-00-3 | Tail gas (petroleum), cracked distillate hydrotreater stripper Petroleum gas<br>[A complex combination of hydrocarbons obtained by treating thermal cracked distillates with hydrogen in the presence of a catalyst. It consists predominantly of saturated hydrocarbons having carbon numbers predominantly in the range of C <sub>1</sub> through C <sub>6</sub> .]  | H K                         | 269-620-9 | 68308-01-0 | Carc. Cat. 1; R45<br>Muta. Cat. 2; R46 | T<br>R: 45-46<br>S: 53-45 |                      |                               |



| Index No     | chemical name  | Notes related to substances | EC No     | CAS No     | Classification                         | Labelling                 | Concentration Limits | Notes related to preparations |
|--------------|--|-----------------------------|-----------|------------|--|---------------------------|----------------------|-------------------------------|
| 649-182-00-9 | Tail gas (petroleum), straight-run distillate hydrodesulfurizer, hydrogen sulfide-free<br>Petroleum gas<br>[A complex combination of hydrocarbons obtained from catalytic hydrodesulfurization of straight run distillates and from which hydrogen sulfide has been removed by amine treatment. It consists predominantly of hydrocarbons having carbon numbers predominantly in the range of C <sub>1</sub> through C <sub>4</sub> .] | H K                         | 269-630-3 | 68308-10-1 | Carc. Cat. 1; R45<br>Muta. Cat. 2; R46 | T<br>R: 45-46<br>S: 53-45 |                      |                               |
| 649-183-00-4 | Tail gas (petroleum), gas oil catalytic cracking absorber<br>Petroleum gas<br>[A complex combination of hydrocarbons obtained from the distillation of products from the catalytic cracking of gas oil. It consists predominantly of hydrocarbons having carbon numbers predominantly in the range of C <sub>1</sub> through C <sub>5</sub> .]   | H K                         | 269-623-5 | 68308-03-2 | Carc. Cat. 1; R45<br>Muta. Cat. 2; R46 | T<br>R: 45-46<br>S: 53-45 |                      |                               |
| 649-184-00-X | Tail gas (petroleum), gas recovery plant<br>Petroleum gas<br>[A complex combination of hydrocarbons from the distillation of products from miscellaneous hydrocarbon streams. It consists predominantly of hydrocarbons having carbon numbers predominantly in the range of C <sub>1</sub> through C <sub>5</sub> .]   | H K                         | 269-624-0 | 68308-04-3 | Carc. Cat. 1; R45<br>Muta. Cat. 2; R46 | T<br>R: 45-46<br>S: 53-45 |                      |                               |

| Index No     | chemical name   | Notes related to substances | EC No     | CAS No     | Classification                         | Labelling                 | Concentration Limits | Notes related to preparations |
|--------------|---|-----------------------------|-----------|------------|--|---------------------------|----------------------|-------------------------------|
| 649-185-00-5 | Tail gas (petroleum), gas recovery plant deethanizer<br>Petroleum gas<br>[A complex combination of hydrocarbons from the distillation of products from miscellaneous hydrocarbon streams. It consists of hydrocarbon having carbon numbers predominantly in the range of C <sub>1</sub> through C <sub>4</sub> .]   | H K                         | 269-625-6 | 68308-05-4 | Carc. Cat. 1; R45<br>Muta. Cat. 2; R46 | T<br>R: 45-46<br>S: 53-45 |                      |                               |
| 649-186-00-0 | Tail gas (petroleum), hydrodesulfurized distillate and hydrodesulfurized naphtha fractionator, acid-free<br>Petroleum gas<br>[A complex combination of hydrocarbons obtained from fractionation of hydrodesulfurized naphtha and distillate hydrocarbon streams and treated to remove acidic impurities. It consists predominantly of hydrocarbons having carbon numbers predominantly in the range of C <sub>1</sub> through C <sub>5</sub> .]   | H K                         | 269-626-1 | 68308-06-5 | Carc. Cat. 1; R45<br>Muta. Cat. 2; R46 | T<br>R: 45-46<br>S: 53-45 |                      |                               |
| 649-187-00-6 | Tail gas (petroleum), hydrodesulfurized vacuum gas oil stripper, hydrogen sulfide-free<br>Petroleum gas<br>[A complex combination of hydrocarbons obtained from stripping stabilization of catalytic hydrodesulfurized vacuum gas oil and from which hydrogen sulfide has been removed by amine treatment. It consists predominantly of hydrocarbons having carbon numbers predominantly in the range of C <sub>1</sub> through C <sub>6</sub> .] | H K                         | 269-627-7 | 68308-07-6 | Carc. Cat. 1; R45<br>Muta. Cat. 2; R46 | T<br>R: 45-46<br>S: 53-45 |                      |                               |

| Index No     | chemical name  | Notes related to substances | EC No     | CAS No     | Classification                         | Labelling                 | Concentration Limits | Notes related to preparations |
|--------------|--|-----------------------------|-----------|------------|--|---------------------------|----------------------|-------------------------------|
| 649-188-00-1 | Tail gas (petroleum), light straight-run naphtha stabilizer, hydrogen sulfide-free petroleum gas<br>[A complex combination of hydrocarbons obtained from fractionation stabilization of light straight run naphtha and from which hydrogen sulfide has been removed by amine treatment. It consists predominantly of hydrocarbons having carbon numbers predominantly in the range of C <sub>1</sub> through C <sub>5</sub> .] | H K                         | 269-629-8 | 68308-09-8 | Carc. Cat. 1; R45<br>Muta. Cat. 2; R46 | T<br>R: 45-46<br>S: 53-45 |                      |                               |
| 649-189-00-7 | Tail gas (petroleum), propane-propylene alkylation feed prep deethanizer<br>Petroleum gas<br>[A complex combination of hydrocarbons obtained from the distillation of the reaction products of propane with propylene. It consists of hydrocarbons having carbon numbers predominantly in the range of C <sub>1</sub> through C <sub>4</sub> .]  | H K                         | 269-631-9 | 68308-11-2 | Carc. Cat. 1; R45<br>Muta. Cat. 2; R46 | T<br>R: 45-46<br>S: 53-45 |                      |                               |

| Index No     | chemical name   | Notes related to substances | EC No     | CAS No     | Classification                         | Labelling                 | Concentration Limits | Notes related to preparations |
|--------------|---|-----------------------------|-----------|------------|--|---------------------------|----------------------|-------------------------------|
| 649-190-00-2 | Tail gas (petroleum), vacuum gas oil hydrodesulfurizer, hydrogen sulfide-free<br>Petroleum gas<br>[A complex combination of hydrocarbons obtained from catalytic hydrodesulfurization of vacuum gas oil and from which hydrogen sulfide has been removed by amine treatment. It consists predominantly of hydrocarbons having carbon numbers predominantly in the range of C <sub>1</sub> through C <sub>6</sub> .] | H K                         | 269-632-4 | 68308-12-3 | Carc. Cat. 1; R45<br>Muta. Cat. 2; R46 | T<br>R: 45-46<br>S: 53-45 |                      |                               |
| 649-191-00-8 | Gases (petroleum), catalytic cracked overheads<br>Petroleum gas<br>[A complex combination of hydrocarbons produced by the distillation of products from the catalytic cracking process. It consists of hydrocarbons having carbon numbers predominantly in the range of C <sub>3</sub> through C <sub>5</sub> and boiling in the range of approximately -48 °C to 32 °C (-54 °F to 90 °F).]                         | H K                         | 270-071-2 | 68409-99-4 | Carc. Cat. 1; R45<br>Muta. Cat. 2; R46 | T<br>R: 45-46<br>S: 53-45 |                      |                               |
| 649-193-00-9 | Alkanes, C <sub>1,2</sub><br>Petroleum gas  | H K                         | 270-651-5 | 68475-57-0 | Carc. Cat. 1; R45<br>Muta. Cat. 2; R46 | T<br>R: 45-46<br>S: 53-45 |                      |                               |
| 649-194-00-4 | Alkanes, C <sub>2,3</sub><br>Petroleum gas  | H K                         | 270-652-0 | 68475-58-1 | Carc. Cat. 1; R45<br>Muta. Cat. 2; R46 | T<br>R: 45-46<br>S: 53-45 |                      |                               |
| 649-195-00-X | Alkanes, C <sub>3,4</sub><br>petroleum gas  | H K                         | 270-653-6 | 68475-59-2 | Carc. Cat. 1; R45<br>Muta. Cat. 2; R46 | T<br>R: 45-46<br>S: 53-45 |                      |                               |

| Index No     | chemical name   | Notes related to substances | EC No     | CAS No     | Classification                         | Labelling                 | Concentration Limits | Notes related to preparations |
|--------------|---|-----------------------------|-----------|------------|--|---------------------------|----------------------|-------------------------------|
| 649-196-00-5 | Alkanes, C <sub>4-5</sub><br>Petroleum gas  | H K                         | 270-654-1 | 68475-60-5 | Carc. Cat. 1; R45<br>Muta. Cat. 2; R46 | T<br>R: 45-46<br>S: 53-45 |                      |                               |
| 649-197-00-0 | Fuel gases<br>Petroleum gas<br>[A combination of light gases. It consists predominantly of hydrogen and/or low molecular weight hydrocarbons.]  | H K                         | 270-667-2 | 68476-26-6 | Carc. Cat. 1; R45<br>Muta. Cat. 2; R46 | T<br>R: 45-46<br>S: 53-45 |                      |                               |
| 649-198-00-6 | Fuel gases, crude oil of distillates<br>Petroleum gas<br>[A complex combination of light gases produced by distillation of crude oil and by catalytic reforming of naphtha. It consists of hydrogen and hydrocarbons having carbon numbers predominantly in the range of C <sub>1</sub> through C <sub>4</sub> and boiling in the range of approximately -217 °C to -12 °C (-423 °F to 10 °F).] | H K                         | 270-670-9 | 68476-29-9 | Carc. Cat. 1; R45<br>Muta. Cat. 2; R46 | T<br>R: 45-46<br>S: 53-45 |                      |                               |
| 649-199-00-1 | Hydrocarbons, C <sub>3-4</sub><br>Petroleum gas   | H K                         | 270-681-9 | 68476-40-4 | Carc. Cat. 1; R45<br>Muta. Cat. 2; R46 | T<br>R: 45-46<br>S: 53-45 |                      |                               |
| 649-200-00-5 | Hydrocarbons, C <sub>4-5</sub><br>Petroleum gas   | H K                         | 270-682-4 | 68476-42-6 | Carc. Cat. 1; R45<br>Muta. Cat. 2; R46 | T<br>R: 45-46<br>S: 53-45 |                      |                               |
| 649-201-00-0 | Hydrocarbons, C <sub>2-4</sub> , C <sub>3</sub> -rich<br>Petroleum gas  | H K                         | 270-689-2 | 68476-49-3 | Carc. Cat. 1; R45<br>Muta. Cat. 2; R46 | T<br>R: 45-46<br>S: 53-45 |                      |                               |

| Index No     | chemical name  | Notes related to substances | EC No     | CAS No     | Classification                                    | Labelling                        | Concentration Limits | Notes related to preparations |
|--------------|--|-----------------------------|-----------|------------|---|----------------------------------|----------------------|-------------------------------|
| 649-202-00-6 | Petroleum gases, liquefied<br>Petroleum gas<br>[A complex combination of hydrocarbons produced by the distillation of crude oil. It consists of hydrocarbons having carbon numbers predominantly in the range of C <sub>3</sub> through C <sub>7</sub> and boiling in the range of approximately -40 °C to 80 °C (-40 °F to 176 °F).]  | HKS                         | 270-704-2 | 68476-85-7 | F+; R12<br>Carc. Cat. 1; R45<br>Muta. Cat. 2; R46 | F+; T<br>R: 12-45-46<br>S: 53-45 |                      |                               |
| 649-203-00-1 | Petroleum gases, liquefied, sweetened<br>Petroleum gas<br>[A complex combination of hydrocarbons obtained by subjecting liquefied petroleum gas mix to a sweetening process to convert mercaptans or to remove acidic impurities. It consists of hydrocarbons having carbon numbers predominantly in the range of C <sub>3</sub> through C <sub>7</sub> and boiling in the range of approximately -40 °C to 80 °C (-40 °F to 176 °F).]                           | HKS                         | 270-705-8 | 68476-86-8 | F+; R12<br>Carc. Cat. 1; R45<br>Muta. Cat. 2; R46 | F+; T<br>R: 12-45-46<br>S: 45-53 |                      |                               |
| 649-204-00-7 | gases (petroleum), C <sub>3-4</sub> , isobutane-rich<br>Petroleum gas<br>[A complex combination of hydrocarbons from the distillation of saturated and unsaturated hydrocarbons usually ranging in carbon numbers from C <sub>3</sub> through C <sub>6</sub> , predominantly butane and isobutane. It consists of saturated and unsaturated hydrocarbons having carbon numbers in the range of C <sub>3</sub> through C <sub>4</sub> , predominantly isobutane.] | H K                         | 270-724-1 | 68477-33-8 | Carc. Cat. 1; R45<br>Muta. Cat. 2; R46            | T<br>R: 45-46<br>S: 53-45        |                      |                               |

| Index No     | chemical name   | Notes related to substances | EC No     | CAS No     | Classification                         | Labelling                 | Concentration Limits | Notes related to preparations |
|--------------|---|-----------------------------|-----------|------------|--|---------------------------|----------------------|-------------------------------|
| 649-205-00-2 | Distillates (petroleum), C <sub>3-6</sub> , piperylene-rich<br>Petroleum gas<br>[A complex combination of hydrocarbons from the distillation of saturated and unsaturated aliphatic hydrocarbons usually ranging in the carbon numbers C <sub>3</sub> through C <sub>6</sub> . It consists of saturated and unsaturated hydrocarbons having carbon numbers in the range of C <sub>3</sub> through C <sub>6</sub> , predominantly piperlenes.] | H K                         | 270-726-2 | 68477-35-0 | Carc. Cat. 1; R45<br>Muta. Cat. 2; R46 | T<br>R: 45-46<br>S: 53-45 |                      |                               |
| 649-206-00-8 | Gases (petroleum), butane splitter overheads<br>Petroleum gas<br>[A complex combination of hydrocarbons obtained from the distillation of the butane stream. It consists of aliphatic hydrocarbons having carbon numbers predominantly in the range of C <sub>3</sub> through C <sub>4</sub> .]   | H K                         | 270-750-3 | 68477-69-0 | Carc. Cat. 1; R45<br>Muta. Cat. 2; R46 | T<br>R: 45-46<br>S: 53-45 |                      |                               |
| 649-207-00-3 | Gases (petroleum), C <sub>2</sub> .<br>Petroleum gas<br>[A complex combination of hydrocarbons produced by the distillation of products from a catalytic fractionation process. It contains predominantly ethane, ethylene, propane, and propylene.]  | H K                         | 270-751-9 | 68477-70-3 | Carc. Cat. 1; R45<br>Muta. Cat. 2; R46 | T<br>R: 45-46<br>S: 53-45 |                      |                               |

| Index No     | chemical name  | Notes related to substances | EC No     | CAS No     | Classification                         | Labelling                 | Concentration Limits | Notes related to preparations |
|--------------|--|-----------------------------|-----------|------------|--|---------------------------|----------------------|-------------------------------|
| 649-208-00-9 | Gases (petroleum), catalytic-cracked gas oil depropanizer bottoms, C <sub>4</sub> -rich acid-free<br>Petroleum gas<br>[A complex combination of hydrocarbons obtained from fractionation of catalytic cracked gas oil hydrocarbon stream and treated to remove hydrogen sulfide and other acidic components. It consists of hydrocarbons having carbon numbers in the range of C <sub>3</sub> through C <sub>5</sub> , predominantly C <sub>4</sub> .] | H K                         | 270-752-4 | 68477-71-4 | Carc. Cat. 1; R45<br>Muta. Cat. 2; R46 | T<br>R: 45-46<br>S: 53-45 |                      |                               |
| 649-209-00-4 | Gases (petroleum), catalytic-cracked naphtha debutanizer bottoms, C <sub>3,5</sub> -rich<br>Petroleum gas<br>[A complex combination of hydrocarbons obtained from the stabilization of catalytic cracked naphtha. It consists of aliphatic hydrocarbons having carbon numbers predominantly in the range of C <sub>3</sub> through C <sub>5</sub> .]   | H K                         | 270-754-5 | 68477-72-5 | Carc. Cat. 1; R45<br>Muta. Cat. 2; R46 | T<br>R: 45-46<br>S: 53-45 |                      |                               |
| 649-210-00-X | Tail gas (petroleum), isomerized naphtha fractionation stabilizer<br>Petroleum gas<br>[A complex combination of hydrocarbons obtained from the fractionation stabilization products from isomerized naphtha. It consists predominantly of hydrocarbons having carbon numbers predominantly in the range of C <sub>1</sub> through C <sub>4</sub> .]  | H K                         | 269-628-2 | 68308-08-7 | Carc. Cat. 1; R45<br>Muta. Cat. 2; R46 | T<br>R: 45-46<br>S: 53-45 |                      |                               |



| Index No     | chemical name   | Notes related to substances | EC No     | CAS No     | Classification    | Labelling                   | Concentration Limits | Notes related to preparations |
|--------------|---|-----------------------------|-----------|------------|-------------------|-----------------------------|----------------------|-------------------------------|
| 649-224-00-6 | Fuels, diesel<br>Gasoil - unspecified<br>[A complex combination of hydrocarbons produced by the distillation of crude oil. It consists of hydrocarbons having carbon numbers predominantly in the range of C <sub>9</sub> through C <sub>20</sub> and boiling in the range of approximately 163 °C to 357 °C (325 °F to 675 °F).] | H N                         | 269-822-7 | 68334-30-5 | Carc. Cat. 3; R40 | Xn<br>R: 40<br>S: (2-)36/37 |                      |                               |

## ANNEX 1C

| Index No      | chemical name  | Notes related to substances | EC No     | CAS No      | Classification                                | Labelling  | Concentration Limits  | Notes related to preparations |
|---------------|--|-----------------------------|-----------|-------------|---|--|---|-------------------------------|
| '005-009-00-3 | tetrabutylammonium butyltriphenylborate  |                             | 418-080-4 | 120307-06-4 | R 43<br>N; R50-53                             | Xi; N<br>R: 43-50/53<br>S: (2-)24-37-56-61                             |   |                               |
| 005-010-00-9  | N,N-dimethylanilinium tetrakis(pentafluorophenyl)borate  |                             | 422-050-6 | 118612-00-3 | Carc.Cat.3; R40<br>Xn; R22<br>Xi; R38-41      | Xn<br>R: 22-38-40-41<br>S: (2-)22-26-36/37/39                          |   |                               |
| 005-012-00-X  | diethyl{4-[1,5,5-tris(4-diethylaminophenyl)penta-2,4-dienylidene]cyclohexa-2,5-dienylidene}ammonium butyltriphenylborate       |                             | 418-070-1 | 141714-54-7 | R 43<br>N; R50-53                             | Xi; N<br>R: 43-50/53<br>S: (2-)24-37-60-61                             |   |                               |
| 011-007-00-3  | propoxycarbazone-sodium  |                             | —         | —           | N; R50-53                                     | N<br>R: 50/53<br>S: 60-61  | C ≥ 2,5 %: N; R50/53<br>0,25 % ≤ C < 2,5 %: N; R51/53<br>0,025 ≤ C < 0,25 %: R52/53 |                               |
| 013-009-00-X  | sodium((n-butyl)x(ethyl)y-1,5-dihydro)aluminate) x = 0.5<br>y = 1.5  |                             | 418-720-2 | —           | F; R11<br>R14/15<br>R 17<br>Xn; R20<br>C; R35 | F; C<br>R: 11-14/15-17-20-35<br>S: (1/2-)6-16-26-30-36/<br>37/39-43-45 |   |                               |
| 014-026-00-5  | dichloro-(3-(3-chloro-4-fluorophenyl)propyl)methylsilane   |                             | 407-180-3 | —           | C; R35  | C<br>R: 35<br>S: (1/2-)26-36/37/39-45                                  |   |                               |
| 014-027-00-0  | chloro(3-(3-chloro-4-fluorophenyl)propyl)dimethylsilane  |                             | 410-270-5 | —           | C; R35  | C<br>R: 35<br>S: (1/2-)8-26-28-36/37/<br>39-45                         |   |                               |
| 014-028-00-6  | α-[3-(1-oxoprop-2-enyl)-1-oxypropyl]dimethoxysilyloxy-ω-[3(1-oxoprop-2-enyl)-1-oxypropyl]dimethoxysilyl poly(dimethylsiloxane) |                             | 415-290-8 | —           | R 43  | Xi<br>R: 43<br>S: (2-)24-37  |   |                               |

| Index No     | chemical name  | Notes related to substances | EC No     | CAS No      | Classification                                | Labelling  | Concentration Limits  | Notes related to preparations |
|--------------|--|-----------------------------|-----------|-------------|---|--|---|-------------------------------|
| 014-029-00-1 | O,O'-(ethenylmethylsilylene)di[(4-methylpentan-2-one)oxime]  |                             | 421-870-1 | —           | Repr.Cat.3; R62<br>Xn; R22-48/22              | Xn<br>R: 22-48/22-62<br>S: (2-)36/37                         |   |                               |
| 014-030-00-7 | [(dimethylsilylene)bis((1,2,3,3a,7a-η)-1H-inden-1-ylidene)dimethyl]hafnium   |                             | 422-060-0 | 137390-08-0 | T+; R28                                       | T+<br>R: 28<br>S: (1/2-)6-22-28-36/37-45                     |   |                               |
| 014-031-00-2 | bis(1-methylethyl)-dimethoxysilane   |                             | 421-540-7 | 18230-61-0  | R 10<br>Xi; R38<br>R43<br>R 52-53             | Xi<br>R: 10-38-43-52/53<br>S: (2-)24-37-61                   |   |                               |
| 014-032-00-8 | dicyclopentyl dimethoxysilane  |                             | 404-370-8 | 126990-35-0 | Xi; R38-41<br>N; R50-53                       | Xi; N<br>R: 38-41-50/53<br>S: (2-)26-37/39-60-61             |   |                               |
| 015-180-00-6 | [R-(R*,S*)]-[[2-methyl-1-(1-oxo-propoxy)propoxy]-(4-phenylbutyl)phosphinyl] acetic acid, (-)-cinchonidine (1:1) salt |                             | 415-820-8 | 137590-32-0 | Xi; R41<br>R 43<br>R 52-53                    | Xi<br>R: 41-43-52/53<br>S: (2-)24-26-37/39-61                |   |                               |
| 015-181-00-1 | phosphine  |                             | 232-260-8 | 7803-51-2   | F+; R12<br>R17<br>T+; R26<br>C; R34<br>N; R50 | F+; T+; N<br>R: 12-17-26-34-50<br>S: (1/2-)28-36/37-45-61-63 |   |                               |
| 015-184-00-8 | Salts of glyphosate, with the exception of those specified elsewhere in this Annex                                   |                             | —         | —           | N; R51-53                                     | N<br>R: 51/53<br>S: 61                                       |   |                               |
| 015-186-00-9 | chlorpyrifos-methyl  |                             | 227-011-5 | 5598-13-0   | R43<br>N; R50-53                              | Xi; N<br>R: 43-50/53<br>S: (2-)36/37-60-61                   | C ≥ 1 %: N; R43-50-53<br>0,0025 % ≤ C < 1 %: N; R50-53<br>0,00025 % ≤ C < 0,0025 %: N; R51-53<br>0,000025 % ≤ C < 0,00025 %: R52-53 |                               |

| Index No     | chemical name   | Notes related to substances | EC No     | CAS No      | Classification               | Labelling  | Concentration Limits | Notes related to preparations |
|--------------|---|-----------------------------|-----------|-------------|------------------------------|--|----------------------|-------------------------------|
| 015-187-00-4 | A mixture of: tetrasodium(((2-hydroxyethyl)imino)bis(methylene))bisphosphonate, N-oxide; trisodium ((tetrahydro-2-hydroxy-4H-1,4,2-oxazaphosphorin-4-yl)-methyl)phosphonate, N-oxide, P-oxide |                             | 417-540-1 | —           | Xi; R41<br>N; R51-53         | Xi; N<br>R: 41-51/53<br>S: (2-)26-39-61          |                      |                               |
| 015-189-00-5 | phenyl bis(2,4,6-trimethylbenzoyl)-phosphine oxide  |                             | 423-340-5 | 162881-26-7 | R43<br>R53                   | Xi<br>R: 43-53<br>S: (2-)22-24-37-61             |                      |                               |
| 016-086-00-8 | tetrasodium 10-amino-6,13-dichloro-3-(3-(4-(2,5-disulfonatoanilino)-6-fluoro-1,3,5-triazin-2-ylamino)prop-3-ylamino)-5,12-dioxo-7,14-diazapentacene-4,11-disulfonate                          |                             | 402-590-9 | 109125-56-6 | Xi; R41                      | Xi<br>R: 41<br>S: (2-)22-26-39                   |                      |                               |
| 016-087-00-3 | A mixture of: thiobis(4,1-phenylene)-S,S,S',S'-tetraphenyl-disulfonium bishexafluorophosphate<br>diphenyl(4-phenylthiophenyl)sulfonium hexafluorophosphate<br>propylene carbonate             |                             | 403-490-8 | 74227-35-3  | Xi; R36<br>R 43<br>N; R50-53 | Xi; N<br>R: 36-43-50/53<br>S: (2-)24-26-37-60-61 |                      |                               |
| 016-088-00-9 | 4-(bis(4-(diethylamino)phenyl)-methyl)benzene-1,2-dimethanesulfonic acid  |                             | 407-280-7 | 71297-11-5  | R 52-53                      | R: 52/53<br>S: 61                                |                      |                               |
| 016-089-00-4 | A mixture of esters of 5,5',6,6',7,7'-hexahydroxy-3,3,3',3'-tetramethyl-1,1'-spirobiindan and 2-diazo-1,2-dihydro-1-oxo-5-sulfonaphthalene  |                             | 413-840-1 | —           | E; R2<br>F; R11<br>R 53      | E<br>R: 2-11-53<br>S: (2-)33-35-40-61            |                      |                               |
| 016-090-00-X | 4-methyl-N-(methylsulfonyl)benzenesulfonamide   |                             | 415-040-8 | 14653-91-9  | Xn; R22<br>Xi; R37-41        | Xn<br>R: 22-37-41<br>S: (2-)26-39                |                      |                               |

| Index No     | chemical name  | Notes related to substances | EC No     | CAS No      | Classification                        | Labelling   | Concentration Limits | Notes related to preparations |
|--------------|--|-----------------------------|-----------|-------------|---------------------------------------|---|----------------------|-------------------------------|
| 016-091-00-5 | C12-14-tert-alkyl ammonium 1-amino-9,10-dihydro-9,10-dioxo-4-(2,4,6-trimethylanilino)-anthracen-2-sulfonate  |                             | 414-110-5 | —           | Xi; R41<br>N; R50-53                  | Xi; N<br>R: 41-50/53<br>S: (2-)26-39-60-61                |                      |                               |
| 016-093-00-6 | A 2:1 mixture of: 4-(7-hydroxy-2,4,4-trimethyl-2-chromanil)resorcinol-4-yl-tris(6-diazo-5,6-dihydro-5-oxonaphthalen-1-sulfonate)<br>4-(7-hydroxy-2,4,4-trimethyl-2-chromanil)resorcinolbis(6-diazo-5,6-dihydro-5-oxonaphthalen-1-sulfonate)  |                             | 414-770-4 | 140698-96-0 | F; R11<br>Carc.Cat.3; R40             | F; Xn<br>R: 11-40<br>S: (2-)7-36/37                       |                      |                               |
| 016-095-00-7 | A mixture of: reaction product of 4,4'-methylenebis[2-(4-hydroxybenzyl)-3,6-dimethylphenol] and 6-diazo-5,6-dihydro-5-oxo-naphthalenesulfonate (1:2)<br>Reaction product of 4,4'-methylenebis[2-(4-hydroxybenzyl)-3,6-dimethylphenol] and 6-diazo-5,6-dihydro-5-oxo-naphthalenesulfonate (1:3) |                             | 417-980-4 | —           | F; R11<br>Carc.Cat.3; R40             | F; Xn<br>R: 11-40<br>S: (2-)7-36/37                       |                      |                               |
| 016-096-00-2 | thifensulfuron-methyl  |                             | —         | 79277-27-3  | N; R50-53                             | N<br>R: 50/53<br>S: 60-61                                 |                      |                               |
| 017-015-00-3 | (2-(aminomethyl)phenyl)acetylchloride hydrochloride  |                             | 417-410-4 | 61807-67-8  | Xn; R22<br>C; R35<br>R43              | C<br>R: 22-35-43<br>S: (1/2-)26-36/37/39-45               |                      |                               |
| 017-016-00-9 | methyltriphenylphosphonium chloride  |                             | 418-400-2 | 1031-15-8   | Xn; R21/22<br>Xi; R38-41<br>N; R51-53 | Xn; N<br>R: 21/22-38-41-51/53<br>S: (2-)22-26-36/37/39-61 |                      |                               |

| Index No     | chemical name  | Notes related to substances | EC No     | CAS No      | Classification              | Labelling  | Concentration Limits | Notes related to preparations |
|--------------|--|-----------------------------|-----------|-------------|-----------------------------|--|----------------------|-------------------------------|
| 017-017-00-4 | (Z)-13-docosenyl-N,N-bis(2-hydroxyethyl)-N-methyl-ammonium-chloride  |                             | 426-210-6 | 120086-58-0 | C; R34<br>N; R50-53         | C; N<br>R: 34-50/53<br>S: (2-)26-36/37/39-45-60-61         |                      |                               |
| 017-018-00-X | N,N,N-trimethyl-2,3-bis(stearoyloxy)propylammonium chloride  |                             | 405-660-7 | —           | N;R51-53                    | N<br>R: 51/53<br>S: 61                                     |                      |                               |
| 017-019-00-5 | (R)-1,2,3,4-tetrahydro-6,7-dimethoxy-1-veratrylisoquinoline hydrochloride  |                             | 415-110-8 | 54417-53-7  | Xn; R22<br>R52-53           | Xn<br>R: 22-52/53<br>S: (2-)22-61                          |                      |                               |
| 017-020-00-0 | ethyl propoxy aluminium chloride   |                             | 421-790-7 | —           | C; R35<br>F; R14/15         | C; F<br>R: 14/15-35<br>S: (1/2-)16-23-26-30-36/37/39-43-45 |                      |                               |
| 017-021-00-6 | behenamidopropyl-dimethyl-(dihydroxypropyl) ammonium chloride  |                             | 423-420-1 | 136920-10-0 | Xi; R41<br>R43<br>N; R50-53 | Xi; N<br>R: 41-43-50/53<br>S: (2-)26-36/37/39-60-61        |                      |                               |
| 020-003-00-0 | A mixture of: dicalcium (bis(2-hydroxy-5-tetra-propenylphenylmethyl)methylamine)dihydroxide tri-calcium (tris(2-hydroxy-5-tetra-propenylphenylmethyl)-methylamine)tri-hydroxide poly[calcium ((2-hydroxy-5-tetra-propenyl-phenylmethyl)-methylamine)hydroxide] |                             | 420-470-4 | —           | Xi; R36/38<br>R43           | Xi<br>R: 36/38-43<br>S: (2-)24-26-37                       |                      |                               |

| Index No     | chemical name  | Notes related to substances | EC No     | CAS No | Classification | Labelling                               | Concentration Limits | Notes related to preparations |
|--------------|--|-----------------------------|-----------|--------|----------------|---|----------------------|-------------------------------|
| 024-019-00-9 | Main component: acetoacetic acid anilide / 3-amino-1-hydroxybenzene (ATAN-MAP): trisodium {6-[(2 or 3 or 4)-amino-(4 or 5 or 6)-hydroxyphenylazo]-5'-(phenylsulfamoyl)-3-sulfonatonaphthalene-2-azobenzene-1,2'-diolato}- {6''-[1-(phenylcarbamoyl)ethylazo]-5'''-(phenylsulfamoyl)-3'''-sulfonatonaphthalene-2''-azobenzene-1'',2'''-diolato}chromate (III)<br>by-product 1: acetoacetic acid anilide / acetoacetic acid anilide (ATAN-ATAN): trisodium bis{6-[1-(phenylcarbamoyl)ethylazo]-5'-(phenylsulfonyl)-3-sulfonatonaphthalene-2-azobenzene-1,2'-diolato}chromate (III)<br>by-product 2: 3-amino-1-hydroxybenzene / 3-amino-1-hydroxybenzene (MAP-MAP): trisodium bis{6-[(2 or 3 or 4)-amino-(4 or 5 or 6)-hydroxyphenylazo]-5'-(phenylsulfamoyl)-3-sulfonatonaphthalene-2-azobenzene-1,2'-diolato}chromate (III) |                             | 419-230-1 | —      | R 43<br>R52-53 | Xi<br>R: 43-52/53<br>S: (2-)22-24-37-61 |                      |                               |
| 024-020-00-4 | trisodium bis[(3'-nitro-5'-sulfonato(6-amino-2-[4-(2-hydroxy-1-naphthylazo)phenylsulfonylamino]pyrimidin-5-azobenzene-2',4-diolato)]chromate(III)  |                             | 418-220-4 | —      | R43<br>R52-53  | Xi<br>R: 43-52/53<br>S: (2-)22-24-37-61 |                      |                               |

| Index No     | chemical name  | Notes related to substances | EC No     | CAS No      | Classification                               | Labelling  | Concentration Limits | Notes related to preparations |
|--------------|--|-----------------------------|-----------|-------------|--|--|----------------------|-------------------------------|
| 025-005-00-5 | A mixture of: tri-sodium [29H, 31H-phthalocyanine-C,C,C-trisulfonato (6-)-N29,N30,N31,N32] manganate (3-)<br>tetrasodium [29H,31H-phthalocyanine-C,C,C,C-tetrasulfonato (6-)-N29,N30,N31,N32], manganate (3-)<br>pentasodium [29H,31H-phthalocyanine-C,C,C,C,C-pentasulfonato (6-)-N29,N30,N31,N32] manganate (3-) |                             | 417-660-4 | —           | N; R50-53                                    | N<br>R: 50/53<br>S: 60-61                                |                      |                               |
| 029-012-00-4 | sodium ((N-(3-trimethylammoniopropyl)sulfamoyl)methylsulfonatophthalocyaninato)copper(II)  |                             | 407-340-2 | 124719-24-0 | Xi; R41                                      | Xi<br>R: 41<br>S: (2-)26-39                              |                      |                               |
| 029-013-00-X | trisodium(2-(a-(3-(4-chloro-6-(2-(vinylsulfonyl)ethoxy)ethylamino)-1,3,5-triazin-2-ylamino)-2-oxido-5-sulfonatophenylazo)-benzylidenehydrazino)-4-sulfonatobenzoato)copper(II)   |                             | 407-580-8 | 130201-51-3 | Xi; R41<br>R52-53                            | Xi<br>R: 41-52/53<br>S: (2-)24-37-61                     |                      |                               |
| 030-011-00-6 | trizinc bis(orthophosphate)  |                             | 231-944-3 | 7779-90-0   | N; R50-53                                    | N<br>R: 50/53<br>S: 60-61                                |                      |                               |
| 030-013-00-7 | zinc oxide   |                             | 215-222-5 | 1314-13-2   | N; R50-53                                    | N<br>R: 50/53<br>S: 60-61                                |                      |                               |
| 034-003-00-3 | sodium selenite  |                             | 233-267-9 | 10102-18-8  | T+; R28<br>T; R23<br>R31<br>R43<br>N; R51-53 | T+; N<br>R: 23-28-31-43-51/53<br>S: (1/2-)28-36/37-45-61 |                      |                               |



| Index No     | chemical name   | Notes related to substances | EC No     | CAS No      | Classification                | Labelling   | Concentration Limits | Notes related to preparations |
|--------------|---|-----------------------------|-----------|-------------|-------------------------------|---|----------------------|-------------------------------|
| 053-005-00-5 | (4-(1-methylethyl)phenyl)-(4-methylphenyl)iodonium tetra-kis(pentafluorophenyl)borate (1-)  |                             | 422-960-3 | 178233-72-2 | Xn; R21/22-48/22<br>N; R50-53 | Xn; N<br>R: 21/22-48/22-50/53<br>S: (2-)22-36/37-60-61  |                      |                               |
| 601-056-00-4 | A mixture of isomers of: methyl-diphenylmethane dimethyl-diphenylmethane  |                             | 405-470-4 | —           | Xi; R38<br>N; R50-53          | Xi; N<br>R: 38-50/53<br>S: (2-)37-60-61                 |                      |                               |
| 601-057-00-X | N-dodecyl-[3-(4-dimethylamino)-benzamido]-propyl]dimethylammonium tosylate  |                             | 421-130-8 | 156679-41-3 | Xi; R41<br>R43<br>N; R50-53   | Xi; N<br>R: 41-43-50/53<br>S: (2-)24-26-37/39-60-61     |                      |                               |
| 601-058-00-5 | di-L-para-menthene  |                             | 417-870-6 | —           | Xi; R38<br>R 43<br>N; R50-53  | Xi; N<br>R: 38-43-50/53<br>S: (2-)23-24-37-60-61        |                      |                               |
| 601-059-00-0 | methyl 2-benzylidene-3-oxobutyrat   |                             | 420-940-9 | 15768-07-7  | Xi; R36/38<br>N; R51-53       | Xi; N<br>R: 36/38-51/53<br>S: (2-)26-37/39-61           |                      |                               |
| 601-060-00-6 | 1,2-bis[4-fluoro-6-(4-sulfo-5-(2-(4-sulfonaphthalene-3-ylazo)-1-hydroxy-3,6-disulfo-8-aminonaphthalene-7-ylazo)phenylamino)-1,3,5-triazin-2-ylamino]ethane;x-sodium, y-potassium salts x = 7,755<br>y = 0,245 |                             | 417-610-1 | 155522-09-1 | R 43                          | Xi<br>R: 43<br>S: (2-)22-24-37                          |                      |                               |
| 601-061-00-1 | (ethyl-1,2-ethanediyl)[-2-[[[(2-hydroxyethyl)methylamino]acetyl]-propyl]ω-(nonylphenoxy)poly]oxy-(methyl-1,2-ethanediyl)  |                             | 418-960-8 | —           | C; R34<br>R 43<br>N; R51-53   | C; N<br>R: 34-43-51/53<br>S: (1/2-)26-28-36/37/39-45-61 |                      |                               |
| 601-062-00-7 | A mixture of: branched triacontane<br>branched dotriacontane<br>branched tetratriacontane<br>branched hexatriacontane   |                             | 417-030-9 | 151006-59-6 | R 53                          | R: 53<br>S: 61  |                      |                               |

| Index No     | chemical name   | Notes related to substances | EC No     | CAS No      | Classification                                      | Labelling  | Concentration Limits | Notes related to preparations |
|--------------|---|-----------------------------|-----------|-------------|---|--|----------------------|-------------------------------|
| 601-063-00-2 | A mixture of isomers of branched tetracosane  |                             | 417-060-2 | 151006-61-0 | Xn; R20<br>R53                                      | Xn<br>R: 20-53<br>S: (2-)61                                  |                      |                               |
| 601-064-00-8 | branched hexatriacontane  |                             | 417-070-7 | 151006-62-1 | R53   | R: 53<br>S: 61   |                      |                               |
| 601-065-00-3 | A mixture of: (1'- $\alpha$ ,3'- $\alpha$ ,6'- $\alpha$ -2,2,3',7',7'-pentamethylspiro(1,3-dioxane-5,2'-norcarane)<br>(1' $\alpha$ ,3' $\beta$ ,6' $\alpha$ )-2,2,3',7',7'-pentamethylspiro(1,3-dioxane-5,2'-norcarane) |                             | 416-930-9 | —           | Xn; R48/22<br>Xi; R41<br>N; R51-53                  | Xn; N<br>R: 41-48/22-51/53<br>S: (2-)22-26-37/39-61          |                      |                               |
| 601-066-00-9 | 1-(4-(trans-4-heptylcyclohexyl)-phenyl)ethane   |                             | 426-820-2 | 78531-60-9  | R43<br>R53  | Xi<br>R: 43-53<br>S: (2-)24-37-61                            |                      |                               |
| 601-067-00-4 | triethyl arsenate   |                             | 427-700-2 | 15606-95-8  | Carc.Cat.1; R45<br>T; R23/25<br>N; R50-53           | T; N<br>R: 45-23/25-50/53<br>S: 53-45-60-61                  |                      |                               |
| 601-068-00-X | 1,2-diacetoxybut-3-ene  |                             | 421-720-5 | 18085-02-4  | Xn; R22   | Xn<br>R: 22<br>S: (2-)                                       |                      |                               |
| 601-069-00-5 | 2-ethyl-1-(2-(1,3-dioxanyl)ethyl)-pyridinium bromide  |                             | 422-680-1 | —           | R52-53  | R: 52/53<br>S: 61  |                      |                               |
| 601-071-00-6 | 1-dimethoxymethyl-2-nitro-benzene   |                             | 423-830-9 | 20627-73-0  | R43<br>N; R51-53                                    | Xi; N<br>R: 43-51/53<br>S: (2-)24-37-61                      |                      |                               |
| 601-073-00-7 | 1-bromo-3,5-difluorobenzene   |                             | 416-710-2 | 461-96-1    | R10<br>Xn; R22-48/22<br>Xi; R38<br>R43<br>N; R50-53 | Xn; N<br>R: 10-22-38-43-48/22-50/53<br>S: (2-)24-36/37-60-61 |                      |                               |

| Index No     | chemical name   | Notes related to substances | EC No                          | CAS No                         | Classification  | Labelling   | Concentration Limits | Notes related to preparations |
|--------------|---|-----------------------------|--------------------------------|--------------------------------|---|---|----------------------|-------------------------------|
| 601-074-00-2 | A mixture of: 4-(2,2,3-trimethylcyclopent-3-en-1-yl)-1-methyl-2-oxabicyclo[2.2.2]octane<br>1-(2,2,3-trimethylcyclopent-3-en-1-yl)-5-methyl-6-oxabicyclo[3.2.1]octane<br>spiro[cyclohex-3-en-1-yl-[(4,5,6,6a-tetrahydro-3,6',6',6'a-tetramethyl)-1,3'(3'aH)-[2H]cyclopenta[b]furan]<br>spiro[cyclohex-3-en-1-yl-[4,5,6,6a-tetrahydro-4,6',6',6'a-tetramethyl)-1,3'(3'aH)-[2H]cyclopenta[b]furan] |                             | 422-040-1                      | —                              | Xi; R36/38<br>N; R51-53   | Xi; N<br>R: 36/38-51/53<br>S: (2-)26-37-61                |                      |                               |
| 602-093-00-9 | $\alpha,\alpha,\alpha,4$ -tetrachlorotoluene p-chlorobenzotrichloride   | E                           | 226-009-1                      | 5216-25-1                      | Carc.Cat.2; R45<br>Repr.Cat.3; R62<br>T; R48/23<br>Xn; R21/22<br>Xi; R37/38 | T<br>R: 45-21/22-37/38-48/<br>23-62<br>S: 53-45           |                      |                               |
| 602-094-00-4 | diphenylether; octabromo derivate   |                             | 251-087-9                      | 32536-52-0                     | Repr.Cat.2; R61<br>Repr.Cat.3; R62  | T<br>R: 61-62<br>S: 53-45                                 |                      |                               |
| 602-096-00-5 | malachite green hydrochloride [1]<br>malachite green oxalate [2]  |                             | 209-322-8 [1]<br>219-441-7 [2] | 569-64-2 [1]<br>18015-76-4 [2] | Xn; R22<br>Xi; R41<br>Repr. Cat. 3; R63<br>N; R50-53                        | Xn; N<br>R: 22-41-63-50/53<br>S: (2-)26-36/37-39-46-60-61 |                      |                               |
| 602-097-00-0 | 1-bromo-9-(4,4,5,5,5-pentafluoropentylthio)nonane   |                             | 422-850-5                      | 148757-89-5                    | R43<br>N; R50-53  | Xi; N<br>R: 43-50/53<br>S: (2-)24-37-60-61                |                      |                               |
| 603-167-00-3 | 3,3',5,5'-tetra-tert-butylbiphenyl-2,2'-diol  |                             | 407-920-5                      | 6390-69-8                      | R 53  | R: 53<br>S: 61  |                      |                               |
| 603-168-00-9 | 3-(2-ethylhexyloxy)propane-1,2-diol   |                             | 408-080-2                      | 70445-33-9                     | Xi; R41<br>R 52-53  | Xi<br>R: 41-52/53<br>S: (2-)26-39-61                      |                      |                               |

| Index No     | chemical name   | Notes related to substances | EC No     | CAS No      | Classification                  | Labelling                                     | Concentration Limits | Notes related to preparations |
|--------------|---|-----------------------------|-----------|-------------|---------------------------------|---|----------------------|-------------------------------|
| 603-169-00-4 | (+/-)-trans-4-(4-fluorophenyl)-3-hydroxymethyl-N-methylpiperidine   |                             | 415-550-0 | 109887-53-8 | Xn; R22<br>Xi; R41<br>N; R51-53 | Xn; N<br>R: 22-41-51/53<br>S: (2-)22-26-39-61 |                      |                               |
| 603-170-00-X | A mixture of: 2-methyl-1-(6-methylbicyclo[2.2.1]hept-5-en-2-yl)pent-1-en-3-ol<br>2-methyl-1-(1-methylbicyclo[2.2.1]hept-5-en-2-yl)pent-1-en-3-ol<br>2-methyl-1-(5-methylbicyclo[2.2.1]hept-5-en-2-yl)pent-1-en-3-ol |                             | 415-990-3 | 67739-11-1  | Xi; R36<br>N; R51-53            | Xi; N<br>R: 36-51/53<br>S: (2-)26-61          |                      |                               |
| 603-171-00-5 | 5-thiazolylmethanol   |                             | 414-780-9 | 38585-74-9  | Xi; R41<br>R 52-53              | Xi<br>R: 41-52/53<br>S: (2-)26-39-61          |                      |                               |
| 603-172-00-0 | mono-2-[2-(4-dibenzoz[b,f][1,4]thiazepin-11-yl)piperazinium-1-yl]ethoxyethanol<br>trans-butenedioate  |                             | 415-180-1 | —           | Xn; R22<br>Xi; R41<br>N; R51-53 | Xn; N<br>R: 22-41-51/53<br>S: (2-)22-26-39-61 |                      |                               |
| 603-173-00-6 | 4,4-dimethyl-3,5,8-trioxabicyclo[5.1.0]octane   |                             | 421-750-9 | 57280-22-5  | Xi; R36<br>R 43                 | Xi<br>R: 36-43<br>S: (2-)26-36/37             |                      |                               |
| 603-174-00-1 | 4-cyclohexyl-2-methyl-2-butanol   |                             | 420-630-3 | 83926-73-2  | Xi; R41<br>N; R51-53            | Xi; N<br>R: 41-51/53<br>S: (2-)26-39-61       |                      |                               |
| 603-175-00-7 | 2-(2-hexyloxyethoxy)ethanol<br>DEGHE<br>diethylene glycol monohexyl ether<br>3,6-dioxa-1-dodecanol<br>hexyl carbitol<br>3,6-dioxadodecan-1-ol   |                             | 203-988-3 | 112-59-4    | Xn; R21<br>Xi; R41              | Xn<br>R: 21-41<br>S: (2-)26-36/37-46          |                      |                               |

| Index No     | chemical name  | Notes related to substances | EC No                          | CAS No                             | Classification                              | Labelling                                       | Concentration Limits                          | Notes related to preparations |
|--------------|--|-----------------------------|--------------------------------|------------------------------------|---|---|---|-------------------------------|
| 603-176-00-2 | 1,2-bis(2-methoxyethoxy)ethane<br>TEGDME<br>triethylene glycol dimethyl ether<br>triglyme  |                             | 203-977-3                      | 112-49-2                           | R19<br>Repr. Cat.2; R61<br>Repr. Cat.3; R62 | T<br>R: 61-19-62<br>S: 53-45                    |   |                               |
| 603-177-00-8 | 1-ethoxypropan-2-ol<br>2PG1EE<br>1-ethoxy-2-propanol<br>propylene glycol monoethyl<br>ether<br>[1]<br>2-ethoxy-1-methylethyl acetate<br>2PG1EEA<br>[2] |                             | 216-374-5 [1]<br>259-370-9 [2] | 1569-02-4 [1]<br>54839-24-6<br>[2] | R10<br>R67                                  | R: 10-67<br>S: (2-)24                           |   |                               |
| 603-178-00-3 | 2-hexyloxyethanol<br>ethylene glycol monohexyl ether<br>n-hexylglycol  |                             | 203-951-1                      | 112-25-4                           | Xn<br>R21/22<br>C; R34                      | C<br>R: 21/22-34<br>S: (1/2-)26-36/37/39-45     |   |                               |
| 603-179-00-9 | ergocalciferol<br>Vitamin D2   |                             | 200-014-9                      | 50-14-6                            | T+; R26<br>T; R24/25-48/25                  | T+<br>R: 24/25-26-48/25<br>S: (1/2-)28-36/37-45 |   |                               |
| 603-180-00-4 | colecalciferol<br>Vitamin D3   |                             | 200-673-2                      | 67-97-0                            | T+; R26<br>T; R24/25-48/25                  | T+<br>R: 24/25-26-48/25<br>S: (1/2-)28-36/37-45 |   |                               |
| 603-181-00-X | tert-butyl methyl ether<br>MTBE<br>2-methoxy-2-methylpropane   |                             | 216-653-1                      | 1634-04-4                          | F; R11<br>Xi; R38                           | F; Xi<br>R: 11-38<br>S: (2-)9-16-24             |   |                               |
| 603-183-00-0 | 2-[2-(2-butoxyethoxy)ethoxy]ethanol<br>TEGBE<br>triethylene glycol monobutyl<br>ether<br>butoxytriethylene glycol                                      |                             | 205-592-6                      | 143-22-6                           | Xi; R41                                     | Xi<br>R: 41<br>S: (2-)26-39-46                  | C ≥ 30 %: Xi; R41<br>20 % ≤ C < 30 %: Xi; R36 |                               |

| Index No     | chemical name  | Notes related to substances | EC No     | CAS No      | Classification                          | Labelling  | Concentration Limits | Notes related to preparations |
|--------------|--|-----------------------------|-----------|-------------|---|--|----------------------|-------------------------------|
| 603-184-00-6 | 2-(hydroxymethyl)-2-[[2-hydroxy-3-(isooctadecyloxy)propoxy]methyl]-1,3-propanediol                                       |                             | 416-380-1 | 146925-83-9 | N; R50-53                               | N<br>R: 50/53<br>S: 60-61                                  |                      |                               |
| 603-185-00-1 | 2,4-dichloro-3-ethyl-6-nitrophenol   |                             | 420-740-1 | 99817-36-4  | T; R25<br>Xi; R41<br>R43<br>N; R50-53   | T; N<br>R: 25-41-43-50/53<br>S: (1/2-)26-36/37/39-45-60-61 |                      |                               |
| 603-186-00-7 | trans-(5RS,6SR)-6-amino-2,2-dimethyl-1,3-dioxepan-5-ol   |                             | 419-050-3 | 79944-37-9  | R 43                                    | Xi<br>R: 43<br>S: (2-)22-24/25-26-37                       |                      |                               |
| 603-187-00-2 | 2-((4,6-bis(4-(2-(1-methylpyridinium-4-yl)vinyl)phenylamino)-1,3,5-triazin-2-yl)(2-hydroxyethyl)amino)ethanol dichloride |                             | 419-360-9 | 163661-77-6 | N; R50-53                               | N<br>R: 50/53<br>S: 60-61                                  |                      |                               |
| 603-189-00-3 | A mixture of complexes of: titanium, 2,2'-oxydiethanol, ammonium lactate, nitrilotris(2-propanol) and ethylene glycol    |                             | 405-250-8 | —           | N; R51-53                               | N<br>R: 51/53<br>S: 61                                     |                      |                               |
| 603-191-00-4 | 2-(4,6-bis(2,4-dimethylphenyl)-1,3,5-triazin-2-yl)-5-(3-((2-ethylhexyl)oxy)-2-hydroxypropoxy)-phenol                     |                             | 419-740-4 | 137658-79-8 | R53                                     | R: 53<br>S: 61   |                      |                               |
| 603-195-00-6 | 2-[4-(4-methoxyphenyl)-6-phenyl-1,3,5-triazin-2-yl]-phenol   |                             | 430-810-3 | 154825-62-4 | R52-53                                  | R: 52/53<br>S: 61  |                      |                               |
| 603-196-00-1 | 2-(7-ethyl-1H-indol-3-yl)ethanol   |                             | 431-020-1 | 41340-36-7  | Xn; 22-48/22<br>N; R51-53               | Xn; N<br>R: 22-48/22-51/53<br>S: (2-)36/37/39-61           |                      |                               |
| 603-197-00-7 | 1-(4-chlorophenyl)-4,4-dimethyl-3-(1,2,4-triazol-1-ylmethyl)pentan-3-ol  |                             | 403-640-2 | 107534-96-3 | Repr.Cat.3; R63<br>Xn; R22<br>N; R51-53 | Xn; N<br>R: 22-51/53-63<br>S: (2-)22-36/37-61              |                      |                               |

| Index No     | chemical name   | Notes related to substances | EC No     | CAS No      | Classification          | Labelling  | Concentration Limits   | Notes related to preparations |
|--------------|---|-----------------------------|-----------|-------------|-------------------------|--|--|-------------------------------|
| 603-199-00-8 | etoxazol  |                             | —         | 153233-91-1 | N; R50-53               | N<br>R: 50/53<br>S: 60-61                        | C ≥ 0.25 %: N; R50/53<br>0.025 % ≤ C < 0.25 %: N; R51/53<br>0.0025 % ≤ C < 0.025 %: R52/53 |                               |
| 604-065-00-1 | 4,4',4''-(1-methylpropan-1-yl-3-ylidene)tris(2-cyclohexyl-5-methylphenol)   |                             | 407-460-5 | 111850-25-0 | N; R51-53               | N<br>R: 51/53<br>S: 61                           |  |                               |
| 604-066-00-7 | A mixture of: phenol, 6-(1,1-dimethylethyl)-4-tetrapropyl-2-[(2-hydroxy-5-tetra-propylphenyl)methyl (C41-compound) and methane, 2,2'-bis[6-(1,1-dimethyl-ethyl)-1-hydroxy-4-tetrapropyl-phenyl]- (C45-compound) 2,6-bis(1,1-dimethylethyl)-4-tetra-propyl-phenol and 2-(1,1-dimethylethyl)-4-tetrapropyl-phenol 2,6-bis[(6-(1,1-dimethylethyl)-1-hydroxy-4-tetrapropylphenyl)-methyl]-4-(tetrapropyl)phenol and 2-[(6-(1,1-dimethylethyl)-1-hydroxy-4-tetrapropylphenyl)-methyl]-6-[1-hydroxy-4-tetrapropylphenyl)methyl]-4-(tetrapropyl)phenol |                             | 414-550-8 | —           | N; R50-53               | N<br>R: 50/53<br>S: 60-61                        |  |                               |
| 604-067-00-2 | A mixture of: 2,2'-[[[2-hydroxyethyl]imino]bis(methylene)bis[4-dodecylphenol] formaldehyde, oligomer with 4-dodecyl phenol and 2-aminoethanol(n = 2) formaldehyde, oligomer with 4-dodecyl phenol and 2-aminoethanol(n = 3, 4 and higher)   |                             | 414-520-4 | —           | Xi; R38-41<br>N; R50-53 | Xi; N<br>R: 38-41-50/53<br>S: (2-)26-37/39-60-61 |  |                               |
| 604-068-00-8 | (+/-)-4-[2-[[3-(4-hydroxyphenyl)-1-methylpropyl]amino]-1-hydroxyethyl]phenol hydrochloride  |                             | 415-170-5 | 99095-19-9  | Xn; R20/22<br>R 43      | Xn<br>R: 20/22-43<br>S: (2-)24-26-37             |  |                               |

| Index No     | chemical name   | Notes related to substances | EC No     | CAS No      | Classification                        | Labelling   | Concentration Limits   | Notes related to preparations |
|--------------|---|-----------------------------|-----------|-------------|---------------------------------------|---|--|-------------------------------|
| 604-069-00-3 | 2-(1-methylpropyl)-4-tert-butylphenol   |                             | 421-740-4 | 51390-14-8  | C; R34<br>N; R51-53                   | C; N<br>R: 34-51/53<br>S: (1/2-)26-36/37/39-45-61 |  |                               |
| 604-070-00-9 | triclosan<br>2,4,4'-trichloro-2'-hydroxy-diphenyl-ether<br>5-chloro-2-(2,4-dichlorophenoxy)phenol   |                             | 222-182-2 | 3380-34-5   | Xi; R36/38<br>N; R50-53               | Xi; N<br>R: 36/38-50/53<br>S: 26-39-46-60-61      | C ≥ 20 %: Xi, N; R36/38-50/53<br>0,25 % ≤ C < 20 %: N; R50/53<br>0,025 % ≤ C < 0,25 %: N; R51/53<br>0,0025 % ≤ C < 0,025 %: R52/53 |                               |
| 605-031-00-9 | A mixture of: 2,2-dimethoxyethanal (this component is considered to be anhydrous in terms of identity, structure and composition. However, 2,2-dimethoxyethanal will exist in a hydrated form. 60 % anhydrous is equivalent to 70.4 % hydrate) water(Including free water and water in hydrated 2,2-dimethoxyethanal) |                             | 421-890-0 | —           | R43                                   | Xi<br>R: 43<br>S: (2-)24-37                       |  |                               |
| 606-062-00-0 | tetrahydrothiopyran-3-carboxaldehyde  |                             | 407-330-8 | 61571-06-0  | Repr.Cat.2; R61<br>Xi; R41<br>R 52-53 | T<br>R: 61-41-52/53<br>S: 53-45-61                |  |                               |
| 606-063-00-6 | (E)-3-(2-chlorophenyl)-2-(4-fluorophenyl)propenal   |                             | 410-980-5 | 112704-51-5 | Xi; R36<br>R 43                       | Xi<br>R: 36-43<br>S: (2-)24-26-37                 |  |                               |
| 606-064-00-1 | pregn-5-ene-3,20-dione bis(ethylene ketal)  |                             | 407-450-0 | 7093-55-2   | R 53                                  | R: 53<br>S: 61                                    |  |                               |
| 606-065-00-7 | 1-(4-morpholinophenyl)butan-1-one   |                             | 413-790-0 | —           | N; R51-53                             | N<br>R: 51/53<br>S: 61                            |  |                               |
| 606-066-00-2 | (E)-5[(4-chlorophenyl)methylene]-2,2-dimethylcyclopentanone   |                             | 410-440-9 | 131984-21-9 | N; R51-53                             | N<br>R: 51/53<br>S: 61                            |  |                               |



| Index No     | chemical name  | Notes related to substances | EC No     | CAS No      | Classification  | Labelling  | Concentration Limits | Notes related to preparations |
|--------------|--|-----------------------------|-----------|-------------|---|--|----------------------|-------------------------------|
| 606-067-00-8 | A mixture of: 1-(2,3,6,7,8,9-hexahydro-1,1-dimethyl-1H-benz(g)inden-4-yl)ethanone<br>1-(2,3,5,6,7,8-hexahydro-1,1-dimethyl-1H-benz(f)inden-4-yl)ethanone<br>1-(2,3,6,7,8,9-hexahydro-1,1-dimethyl-1H-benz(g)inden-5-yl)ethanone<br>1-(2,3,6,7,8,9-hexahydro-3,3-dimethyl-1H-benz(g)inden-5-yl)ethanone |                             | 414-870-8 | 96792-67-5  | N; R50-53   | N<br>R: 50/53<br>S: 60-61                              |                      |                               |
| 606-068-00-3 | 2,7,11-trimethyl-13-(2,6,6-trimethylcyclohex-1-en-1-yl)tridecahexaen-2,4,6,8,10,12-al  |                             | 415-770-7 | 1638-05-7   | Xn; R48/22<br>R 43<br>R 52-53                         | Xn<br>R: 43-48/22-52/53<br>S: (2-)22-36/37-61          |                      |                               |
| 606-069-00-9 | spiro[1,3-dioxolane-2,5'-(4',4',8',8'-tetramethyl-hexahydro-3',9'-methanonaphthalene)]   |                             | 415-460-1 | 154171-77-4 | N; R51-53   | N<br>R: 51/53<br>S: 24-61                              |                      |                               |
| 606-070-00-4 | 5-(3-butyryl-2,4,6-trimethylphenyl)-2-[1-(ethoxyimino)propyl]-3-hydroxycyclohex-2-en-1-one   |                             | 414-790-3 | 138164-12-2 | Repr.Cat.3; R62-63<br>Xn; R22<br>Xi; R38<br>N; R50-53 | Xn; N<br>R: 22-38-62-63-50/53<br>S: (2-)22-36/37-60-61 |                      |                               |
| 606-071-00-X | 17-spiro(5,5-dimethyl-1,3-dioxan-2-yl)androsta-1,4-diene-3-one   |                             | 421-050-3 | 13258-43-0  | N; R50-53   | N<br>R: 50/53<br>S: 22-60-61                           |                      |                               |
| 606-072-00-5 | 3-acetyl-1-phenyl-pyrrolidine-2,4-dione  |                             | 421-600-2 | 719-86-8    | Xn; R48/22<br>N; R51-53                               | Xn; N<br>R: 48/22-51/53<br>S: (2-)22-36/37-61          |                      |                               |
| 606-073-00-0 | 4,4'-bis(dimethylamino)benzophenone<br>Michler's ketone  |                             | 202-027-5 | 90-94-8     | Carc.Cat.2; R45<br>Muta.Cat.3; R68<br>Xi; R41         | T<br>R: 45-41-68<br>S: 53-45                           |                      |                               |
| 606-075-00-1 | 1-benzyl-5-ethoxyimidazolidine-2,4-dione   |                             | 417-340-4 | 65855-02-9  | Xn; R22   | Xn<br>R: 22<br>S: (2-)22                               |                      |                               |

| Index No     | chemical name  | Notes related to substances | EC No     | CAS No      | Classification              | Labelling   | Concentration Limits | Notes related to preparations |
|--------------|--|-----------------------------|-----------|-------------|-----------------------------|---|----------------------|-------------------------------|
| 606-076-00-7 | 1-((2-quinolinyl-carbonyl)oxy)-2,5-pyrrolidinedione                              |                             | 418-630-3 | 136465-99-1 | Xi; R41<br>R43              | Xi<br>R: 41-43<br>S: (2-)24-26-37/39                    |                      |                               |
| 606-077-00-2 | (3S,4S)-3-hexyl-4-[(R)-2-hydroxytridecyl]-2-oxetanone                            |                             | 418-650-2 | 104872-06-2 | N; R50-53                   | N<br>R: 50/53<br>S: 60-61                               |                      |                               |
| 606-078-00-8 | 1-octylazepin-2-one  |                             | 420-040-6 | 59227-88-2  | C; R34<br>R 43<br>N; R51-53 | C; N<br>R: 34-43-51/53<br>S: (1/2-)26-36/37/39-45-61    |                      |                               |
| 606-079-00-3 | 2-n-butyl-benzo[d]isothiazol-3-one   |                             | 420-590-7 | —           | C; R34<br>R43<br>N; R50-53  | C; N<br>R: 34-43-50/53<br>S: (1/2-)26-36/37/39-45-60-61 |                      |                               |
| 606-080-00-9 | Reaction product of: 3-hydroxy-5,7-di-tert-butylbenzofuran-2-one with o-xylene   |                             | 417-100-9 | —           | R 53                        | R: 53<br>S: 61  |                      |                               |
| 606-081-00-4 | (3β, 5α, 6β)-3-(acetyloxy)-5-bromo-6-hydroxy-androstan-17-one                    |                             | 419-790-7 | 4229-69-0   | R43<br>R52-53               | Xi<br>R: 43-52/53<br>S: (2-)22-36/37-61                 |                      |                               |
| 606-082-00-X | A mixture of: butan-2-one oxime<br>syn-O,O'-di(butan-2-one oxime)-diethoxysilane |                             | 406-930-7 | 96-29-7     | T; R48/22<br>R43<br>R52-53  | T<br>R: 43-48/25-52/53<br>S: (1/2-)25-36/37-45-61       |                      |                               |
| 606-083-00-5 | 2-chloro-5-sec-hexadecylhydroquinone   |                             | 407-750-1 | —           | Xi; R36/38<br>R43<br>R52-53 | Xi<br>R: 36/38-43-52/53<br>S: (2-)24-26-37-61           |                      |                               |
| 606-084-00-0 | 1-(4-methoxy-5-benzofuranyl)-3-phenyl-1,3-propanedione                           |                             | 414-540-3 | 484-33-3    | N; R50-53                   | N<br>R: 50/53<br>S: 60-61                               |                      |                               |
| 606-085-00-6 | (1R,4S)-2-azabicyclo[2.2.1]hept-5-en-3-one                                       |                             | 418-530-1 | 79200-56-9  | Xn; R22<br>Xi; R41<br>R43   | Xn<br>R: 22-41-43<br>S: (2-)24-26-37/39                 |                      |                               |

| Index No     | chemical name   | Notes related to substances | EC No     | CAS No      | Classification       | Labelling                            | Concentration Limits | Notes related to preparations |
|--------------|---|-----------------------------|-----------|-------------|----------------------|--------------------------------------|----------------------|-------------------------------|
| 606-086-00-1 | 1-(3,3-dimethylcyclohexyl)pent-4-en-1-one   |                             | 422-330-8 | 56973-87-6  | N; R51-53            | N<br>R: 51/53<br>S: 61               |                      |                               |
| 606-087-00-7 | 6-ethyl-5-fluoro-4(3H)-pyrimidone   |                             | 422-460-5 | 137234-87-8 | Xn; R22<br>N; R50-53 | Xn; N<br>R: 22-50/53<br>S: (2-)60-61 |                      |                               |
| 606-088-00-2 | 2,4,4,7-tetramethyl-6-octen-3-one   |                             | 422-520-0 | 74338-72-0  | Xi; R38<br>N; R51-53 | Xi; N<br>R: 38-51/53<br>S: (2-)37-61 |                      |                               |
| 606-089-00-8 | A mixture of: 1,4-diamino-2-chloro-3-phenoxyanthraquinone<br>1,4-diamino-2,3-bis-phenoxyanthraquinone   |                             | 423-220-2 | 12223-77-7  | R53                  | R: 53<br>S: 61                       |                      |                               |
| 606-091-00-9 | 6-chloro-5-(2-chloroethyl)-1,3-dihydroindol-2-one   |                             | 421-320-0 | 118289-55-7 | N; R50-53            | N<br>R: 50/53<br>S: 60-61            |                      |                               |
| 606-092-00-4 | A mixture of: (E)-oxacyclohexadec-12-en-2-one<br>(E)-oxacyclohexadec-13-en-2-one<br>a) (Z)-oxacyclohexadec-(12)-en-2-one and b) (Z)-oxacyclohexadec-(13)-en-2-one   |                             | 422-320-3 | 111879-80-2 | N; R50-53            | N<br>R: 50/53<br>S: 60-61            |                      |                               |
| 607-379-00-7 | A mixture of: 2-[N-(2-hydroxyethyl)stearamido]ethyl stearate<br>sodium [bis[2-(stearoyloxy)ethyl]amino]methylsulfonate<br>sodium [bis(2-hydroxyethyl)amino]methylsulfonate<br>N,N-bis(2-hydroxyethyl)stearamide |                             | 401-230-8 | 55349-70-7  | R52-53               | R: 52/53<br>S: 61                    |                      |                               |

| Index No     | chemical name   | Notes related to substances | EC No     | CAS No      | Classification               | Labelling   | Concentration Limits | Notes related to preparations |
|--------------|---|-----------------------------|-----------|-------------|------------------------------|---|----------------------|-------------------------------|
| 607-380-00-2 | A mixture of: ammonium-1,2-bis(hexyloxycarbonyl)ethanesulfonate<br>ammonium-1-hexyloxycarbonyl-2-octyloxycarbonylethanesulfonate<br>ammonium-2-hexyloxycarbonyl-1-octyloxycarbonylethanesulfonate   |                             | 407-320-3 | —           | Xi; R38-41<br>R 52-53        | Xi<br>R: 38-41-52/53<br>S: (2-)26-37/39-61          |                      |                               |
| 607-381-00-8 | mixed triesters of 2,2-bis(hydroxymethyl)butanol with C7-alkanoic acids and 2-ethylhexanoic acid  |                             | 413-710-4 | —           | R 53                         | R: 53<br>S: 61                                      |                      |                               |
| 607-382-00-3 | 2-((4-amino-2-nitrophenyl)amino)benzoic acid  |                             | 411-260-3 | 117907-43-4 | Xi; R41<br>R 43<br>R 52-53   | Xi<br>R: 41-43-52/53<br>S: (2-)24-26-37/39-61       |                      |                               |
| 607-383-00-9 | A mixture of: 2,2,6,6-tetramethylpiperidin-4-yl-hexadecanoate<br>2,2,6,6-tetramethylpiperidin-4-yl-octadecanoate  |                             | 415-430-8 | 86403-32-9  | Xi; R41<br>R 43<br>N; R50-53 | Xi; N<br>R: 41-43-50/53<br>S: (2-)24-26-37/39-60-61 |                      |                               |
| 607-384-00-4 | A mixture of: esters of C14-C15 branched alcohols with 3,5-di- <i>t</i> -butyl-4-hydroxyphenyl propionic acid<br>C15 branched and linear alkyl 3,5-bis(1,1-dimethylethyl)-4-hydroxybenzenepropanoate<br>C13 branched and linear alkyl 3,5-bis(1,1-dimethylethyl)-4-hydroxybenzenepropanoate |                             | 413-750-2 | 171090-93-0 | R 53                         | R: 53<br>S: 61                                      |                      |                               |
| 607-385-00-X | Copolymer of vinyl-alcohol and vinyl acetate partially acetylated with 4-(2-(4-formylphenyl)ethenyl)-1-methylpyridinium methylsulfate   |                             | 414-590-6 | 125229-74-5 | N; R51-53                    | N<br>R: 51/53<br>S: 61                              |                      |                               |

| Index No     | chemical name   | Notes related to substances | EC No     | CAS No      | Classification                  | Labelling  | Concentration Limits | Notes related to preparations |
|--------------|---|-----------------------------|-----------|-------------|---------------------------------|--|----------------------|-------------------------------|
| 607-386-00-5 | A mixture of: tetradecanoic acid (42.5-47.5 %)<br>poly(1-7)lactate esters of tetradecanoic acid (52.5-57.5 %) |                             | 412-580-6 | 174591-51-6 | Xi; R38-41<br>R 43<br>N; R50-53 | Xi; N<br>R: 38-41-43-50/53<br>S: (2-)24-26-37/39-60-61 |                      |                               |
| 607-387-00-0 | A mixture of: dodecanoic acid (35-40 %)<br>poly(1-7)lactate esters of dodecanoic acid (60-65 %)               |                             | 412-590-0 | 58856-63-6  | Xi; R38-41<br>R 43<br>N; R50-53 | Xi; N<br>R: 38-41-43-50/53<br>S: (2-)24-26-37/39-60-61 |                      |                               |
| 607-388-00-6 | 4-ethylamino-3-nitrobenzoic acid  |                             | 412-090-2 | 2788-74-1   | Xn; R22<br>R 43<br>R 52-53      | Xn<br>R: 22-43-52/53<br>S: (2-)22-24-37-61             |                      |                               |
| 607-389-00-1 | trisodium N,N-bis(carboxymethyl)-3-amino-2-hydroxypropionate  |                             | 414-130-4 | 119710-96-2 | Xn; R22                         | Xn<br>R: 22<br>S: (2-)22                               |                      |                               |
| 607-390-00-7 | 1,2,3,4-tetrahydro-6-nitro-quinoxaline  |                             | 414-270-6 | 41959-35-7  | Xn; R22<br>N; R51-53            | Xn; N<br>R: 22-51/53<br>S: (2-)22-61                   |                      |                               |
| 607-391-00-2 | dimethylcyclopropane-1,1-dicarboxylate  |                             | 414-240-2 | 6914-71-2   | R 52-53                         | R: 52/53<br>S: 61                                      |                      |                               |
| 607-392-00-8 | 2-phenoxyethyl 4-((5-cyano-1,6-dihydro-2-hydroxy-1,4-dimethyl-6-oxo-3-pyridinyl)azo)benzoate                  |                             | 414-260-1 | 88938-37-8  | R 53                            | R: 53<br>S: 61   |                      |                               |
| 607-393-00-3 | 3-(cis-1-propenyl)-7-amino-8-oxo-5-thia-1-azabicyclo[4.2.0]oct-2-ene-2-carboxylic acid                        |                             | 415-750-8 | 106447-44-3 | R 43                            | Xi<br>R: 43<br>S: (2-)22-24-37                         |                      |                               |
| 607-394-00-9 | 5-methylpyrazine-2-carboxylic acid  |                             | 413-260-9 | 5521-55-1   | Xi; R41                         | Xi<br>R: 41<br>S: (2-)26-39                            |                      |                               |

| Index No     | chemical name  | Notes related to substances | EC No     | CAS No      | Classification              | Labelling  | Concentration Limits | Notes related to preparations |
|--------------|--|-----------------------------|-----------|-------------|-----------------------------|--|----------------------|-------------------------------|
| 607-395-00-4 | A mixture of: sodium 1-tridecyl-4-allyl-(2 or 3)-sulfobutanedioate<br>sodium 1-dodecyl-4allyl-(2 or 3)-sulfobutanedioate   |                             | 410-230-7 | —           | C; R34<br>R 43<br>N; R51-53 | C; N<br>R: 34-43-51/53<br>S: (1/2-)26-36/37/39-45-61 |                      |                               |
| 607-396-00-X | bis(1,2,2,6,6-pentamethyl-4-piperidinyl) 2-(4-methoxybenzylidene)malonate  |                             | 414-840-4 | 147783-69-5 | N; R50-53                   | N<br>R: 50/53<br>S: 22-60-61                         |                      |                               |
| 607-397-00-5 | A mixture of: Ca salicylates (branched C10-14 and C18-30 alkylated)<br>Ca phenates (branched C10-14 and C18-30 alkylated)<br>Ca sulfurized phenates (branched C10-14 and C18-30 alkylated) |                             | 415-930-6 | —           | R 43                        | Xi<br>R: 43<br>S: (2-)36/37                          |                      |                               |
| 607-398-00-0 | ethyl N-(5-chloro-3-(4-(diethylamino)-2-methylphenylimino)-4-methyl-6-oxo-1,4-cyclohexadienyl)carbamate  |                             | 414-820-5 | 125630-94-6 | N; R50-53                   | N<br>R: 50/53<br>S: 60-61                            |                      |                               |
| 607-399-00-6 | 2,2-dimethyl 3-methyl-3-butenyl propanoate   |                             | 415-610-6 | 104468-21-5 | Xi; R38<br>R52-53           | Xi<br>R: 38-52/53<br>S: (2-)37-61                    |                      |                               |
| 607-400-00-X | methyl 3-[[[(dibutylamino)thioxomethyl]-thio]propanoate  |                             | 414-400-1 | 32750-89-3  | N; R50-53                   | N<br>R: 50/53<br>S: 60-61                            |                      |                               |
| 607-401-00-5 | ethyl 3-hydroxy-5-oxo-3-cyclohexene-1-carboxylate  |                             | 414-450-4 | 88805-65-6  | Xi; R38-41<br>R 43          | Xi<br>R: 38-41-43<br>S: (2-)24-26-37/39              |                      |                               |
| 607-402-00-0 | methyl N-(phenoxy-carbonyl)-L-valinate   |                             | 414-500-5 | 153441-77-1 | R 52-53                     | R: 52/53<br>S: 61                                    |                      |                               |

| Index No     | chemical name  | Notes related to substances | EC No     | CAS No      | Classification                           | Labelling  | Concentration Limits | Notes related to preparations |
|--------------|--|-----------------------------|-----------|-------------|--|--|----------------------|-------------------------------|
| 607-403-00-6 | A mixture of: bis(1S,2S,4S)-(1-benzyl-4-tert-butoxycarbonylamido-2-hydroxy-5-phenyl)pentylammonium succinate isopropyl alcohol   |                             | 414-810-0 | —           | Xn; R48/22<br>Xi; R41<br>N; R50-53       | Xn; N<br>R: 41-48/22-50/53<br>S: (2-)22-26-36/39-60-61 |                      |                               |
| 607-404-00-1 | A mixture of: ((Z)-3,7-dimethyl-2,6-octadienyl)oxycarbonylpropanoic acid<br>di-((E)-3,7-dimethyl-2,6-octadienyl) butandioate<br>di-((Z)-3,7-dimethyl-2,6-octadienyl) butandioate<br>(Z)-3,7-dimethyl-2,6-octadienyl butandioate<br>(E)-3,7-dimethyl-2,6-octadienyl oxycarbonylpropanoic acid |                             | 415-190-4 | —           | R 43                                     | Xi<br>R: 43<br>S: (2-)24-37                            |                      |                               |
| 607-405-00-7 | 2-hexyldecyl p-hydroxybenzoate   |                             | 415-380-7 | 148348-12-3 | N; R51-53                                | N<br>R: 51/53<br>S: 61                                 |                      |                               |
| 607-406-00-2 | potassium 2,5-dichlorobenzoate   |                             | 415-700-5 | —           | Xn; R22<br>Xi; R41                       | Xn<br>R: 22-41<br>S: (2-)26-39                         |                      |                               |
| 607-407-00-8 | ethyl 2-carboxy-3-(2-thienyl)propionate  |                             | 415-680-8 | 143468-96-6 | Xi; R38-41<br>R 43                       | Xi<br>R: 38-41-43<br>S: (2-)24-26-37/39                |                      |                               |
| 607-408-00-3 | potassium N-(4-fluorophenyl)glycinate  |                             | 415-710-1 | —           | Xn; R48/22<br>Xi; R41<br>R 43<br>R 52-53 | Xn<br>R: 41-43-48/22-52/53<br>S: (2-)22-26-36/37/39-61 |                      |                               |
| 607-409-00-9 | A mixture of: (3R)-[1S-(1a, 2a, 6β)-((2S)-2-methyl-1-oxobutoxy)-8a.γ)]hexahydro-2,6-dimethyl-1-naphthalene]-3,5-dihydroxyheptanoic acid inert biomass from Aspergillus terreus   |                             | 415-840-7 | —           | R 43<br>R 52-53                          | Xi<br>R: 43-52/53<br>S: (2-)36/37-61                   |                      |                               |

| Index No     | chemical name  | Notes related to substances | EC No     | CAS No      | Classification  | Labelling  | Concentration Limits | Notes related to preparations |
|--------------|--|-----------------------------|-----------|-------------|---|--|----------------------|-------------------------------|
| 607-410-00-4 | mono[2-(dimethylamino)ethyl]-monohydrogen-2-(hexadec-2-enyl)butanedioate and/or mono[2-(dimethylamino)ethyl]-monohydrogen-3-(hexadec-2-enyl)butanedioate |                             | 415-880-5 | —           | Xi; R38-41<br>R 43<br>N; R50-53                                   | Xi; N<br>R: 38-41-43-50/53<br>S: (2-)24-26-37/39-60-61 |                      |                               |
| 607-411-00-X | oxiranemethanol, 4-methylbenzene-sulfonate, (S)-   |                             | 417-210-7 | 70987-78-9  | Carc.Cat.2; R45<br>Muta.Cat.3; R68<br>Xi; R41<br>R43<br>N; R51-53 | T; N<br>R: 45-41-43-51/53<br>S: 53-45-61               |                      |                               |
| 607-412-00-5 | ethyl 2-(1-cyanocyclohexyl)acetate   |                             | 415-970-4 | 133481-10-4 | Xn; R22-48/22<br>R 52-53  | Xn<br>R: 22-48/22-52/53<br>S: (2-)36/37-61             |                      |                               |
| 607-413-00-0 | trans-4-phenyl-L-proline   |                             | 416-020-1 | 96314-26-0  | Repr.Cat.3; R62<br>R 43   | Xn<br>R: 43-62<br>S: (2-)22-36/37                      |                      |                               |
| 607-414-00-6 | tris(2-ethylhexyl)-4,4',4''-(1,3,5-triazine-2,4,6-triyltriimino)tribenzoate  |                             | 402-070-1 | 88122-99-0  | R53   | R: 53<br>S: 61   |                      |                               |
| 607-415-00-1 | poly-(methyl methacrylate)-co-(butylmethacrylate)-co-(4-acryloxybutyl-isopropenyl-.alpha.,.alpha.-dimethylbenzyl carbamate)-co-(maleicanhydride)         |                             | 419-590-1 | —           | F; R11<br>R 43  | F; Xi<br>R: 11-43<br>S: (2-)24-37-43                   |                      |                               |
| 607-416-00-7 | 4-(2-carboxymethylthio)ethoxy-1-hydroxy-5-isobutyloxycarbonylamino-N-(3-dodecyloxypropyl)-2-naphthamide  |                             | 420-730-7 | —           | N; R50-53   | N<br>R: 50/53<br>S: 60-61                              |                      |                               |
| 607-418-00-8 | 2-ethylhexyl 4-aminobenzoate   |                             | 420-170-3 | 26218-04-2  | N; R50-53   | N<br>R: 50/53<br>S: 60-61                              |                      |                               |



| Index No     | chemical name   | Notes related to substances | EC No     | CAS No      | Classification                               | Labelling  | Concentration Limits | Notes related to preparations |
|--------------|---|-----------------------------|-----------|-------------|--|--|----------------------|-------------------------------|
| 607-419-00-3 | (3'-carboxymethyl-5-(2-(3-ethyl-3H-benzothiazol-2-ylidene)-1-methyl-ethylidene)-4,4'-dioxo-2'-thioxo-(2,5')bithiazolidinylden-3-yl)-acetic acid             |                             | 422-240-9 | 166596-68-5 | Xi; R41<br>R 43                              | Xi<br>R: 41-43<br>S: (2-)26-36/37/39                     |                      |                               |
| 607-420-00-9 | 2,2-bis(hydroxymethyl)butanoic acid   |                             | 424-090-1 | 10097-02-6  | Xi; R41<br>R52-53                            | Xi<br>R: 41-52/53<br>S: (2-)26-39-61                     |                      |                               |
| 607-421-00-4 | cypermethrin <i>cis/trans</i> +/- 40/60 (RS)- $\alpha$ -cyano-3-phenoxybenzyl (1RS,3RS;1RS,3SR)-3-(2,2-dichlorovinyl)-2,2-dimethylcyclopropanecarboxylate   |                             | 257-842-9 | 52315-07-8  | Xn; R20/22<br>Xi; R37<br>N; R50-53           | Xn; N<br>R: 20/22-37-50/53<br>S: (2-)24-36/37/39-60-61   |                      |                               |
| 607-422-00-X | $\alpha$ -cypermethrin  |                             | 257-842-9 | 67375-30-8  | T; R25<br>Xn; R48/22<br>Xi; R37<br>N; R50-53 | T; N<br>R: 25-37-48/22-50/53<br>S: (2-)36/37/39-45-60-61 |                      |                               |
| 607-423-00-5 | esters of mecoprop and of mecoprop-P  |                             | —         | —           | Xn; R22<br>R43<br>N; R50-53                  | Xn; N<br>R: 22-43-50/53<br>S: (2-)13-36/37-60-61         |                      |                               |
| 607-424-00-0 | trifloxystrobin (ISO) ( <i>E,E</i> )- $\alpha$ -methoxyimino-{2-[[[1-[3-(trifluoromethyl)phenyl]ethylidene]amino]oxy]methyl]benzeneacetic acid methyl ester |                             | —         | 141517-21-7 | R43<br>N; R50-53                             | Xi; N<br>R: 43-50/53<br>S: (2-)24-37-46-60-61            |                      |                               |
| 607-425-00-6 | metalaxyl (ISO) methyl-N-(2,6-dimethylphenyl)-N-(methoxyacetyl)-DL-alaninate  |                             | 260-979-7 | 57837-19-1  | Xn; R22<br>R43<br>R52-53                     | Xn<br>R: 22-43-52/53<br>S: (2-)13-24-37-46-61            |                      |                               |

| Index No     | chemical name   | Notes related to substances | EC No  | CAS No  | Classification                                    | Labelling  | Concentration Limits | Notes related to preparations |
|--------------|---|-----------------------------|--|---|---|--|----------------------|-------------------------------|
| 607-426-00-1 | 1,2-benzenedicarboxylic acid, dipentylester, branched and linear<br>[1]<br>n-pentyl-isopentylphthalate<br>[2]<br>di-n-pentyl phthalate<br>[3]<br>diisopentylphthalate<br>[4]  |                             | 284-032-2 [1]<br>- [2]<br>205-017-9 [3]<br>210-088-4 [4] | 84777-06-0 [1]<br>- [2]<br>131-18-0 [3]<br>605-50-5 [4] | Repr. Cat. 2; R60-61<br>N; R50                    | T; N<br>R: 60-61-50<br>S: 53-45-61                     |                      |                               |
| 607-427-00-7 | bromoxynil heptanoate (ISO)<br>2,6-dibromo-4-cyanophenyl heptanoate   |                             | 260-300-4  | 56634-95-8  | Repr.Cat3; R63<br>Xn; R20/22<br>R43<br>N; R50-53  | Xn; N<br>R: 20/22-43-63-50/53<br>S: (2-)36/37-46-60-61 |                      |                               |
| 607-430-00-3 | BBP<br>benzyl butyl phtalate  |                             | 201-622-7  | 85-68-7   | Repr. Cat.2; R61<br>Repr. Cat.3; R62<br>N; R50-53 | T; N<br>R: 61-62-50/53<br>S: 53-45-60-61               |                      |                               |
| 607-431-00-9 | prallethrin<br>ETOC<br>2-methyl-4-oxo-3-(prop-2-ynyl)-cyclopent-2-en-1-yl 2,2-dimethyl-3-(2-methylprop-1-enyl)cyclopropanecarboxylate   |                             | 245-387-9  | 23031-36-9  | T; R23<br>Xn; R22<br>N; R50-53                    | T; N<br>R: 22-23-50/53<br>S: (1/2-)45-60-61            |                      |                               |
| 607-432-00-4 | S-metolachlor<br>mixture of (S)-2-chloro-N-(2-ethyl-6-methyl-phenyl)-N-(2-methoxy-1-methyl-ethyl)-acetamide (80-100 %)<br>[1]<br>S-metolachlor<br>(R)-2-chloro-N-(2-ethyl-6-methyl-phenyl)-N-(2-methoxy-1-methyl-ethyl)-acetamide (0-20 %)<br>[2] |                             | - [1]<br>- [2]   | 87392-12-9 [1]<br>178961-20-1<br>[2]                    | R43<br>N; R50-53                                  | Xi; N<br>R: 43-50/53<br>S: (2-)24-37-60-61             |                      |                               |

| Index No     | chemical name   | Notes related to substances | EC No     | CAS No      | Classification                            | Labelling  | Concentration Limits | Notes related to preparations |
|--------------|---|-----------------------------|-----------|-------------|---|--|----------------------|-------------------------------|
| 607-433-00-X | cypermethrin <i>cis/trans</i> +/- 80/20 (RS)- $\alpha$ -cyano-3-phenoxybenzyl (1RS ; 3RS ; 1RS , 3SR)-3-(2,2-dichlorovinyl)-2,2-dimethylcyclopropanecarboxylate |                             | 257-842-9 | 52315-07-8  | Xn; R22<br>Xi; R37/38<br>R43<br>N; R50-53 | Xn; N<br>R: 22-37/38-43-50/53<br>S: (2-)36/37/39-60-61 |                      |                               |
| 607-434-00-5 | mecoprop-P [1] and its salts (R)-2-(4-chloro-2-methylphenoxy)propionic acid   |                             | 240-539-0 | 16484-77-8  | Xn; R22<br>Xi; R41<br>N; R51-53           | Xn; N<br>R: 22-41-51/53<br>S: (2-)13-26-37/39-46-61    |                      |                               |
| 607-435-00-0 | 2S-isopropyl-5R-methyl-1R-cyclohexyl 2,2-dihydroxyacetate   |                             | 416-810-6 | 111969-64-3 | Xn; R48/22<br>Xi; R41<br>N; R51-53        | Xn; N<br>R: 41-48/22-51/53<br>S: (2-)22-26-36/39-61    |                      |                               |
| 607-436-00-6 | 2-hydroxy-3-(2-ethyl-4-methylimidazol)propyl neodecanoate   |                             | 417-350-9 | —           | Xi; R38-41<br>N; R50-53                   | Xi; N<br>R: 38-41-50/53<br>S: (2-)26-28-37/39-60-61    |                      |                               |
| 607-437-00-1 | 3-(4-aminophenyl)-2-cyano-2-propenoic acid  |                             | 417-480-6 | —           | R43                                       | Xi<br>R: 43<br>S: (2-)22-24-37                         |                      |                               |
| 607-438-00-7 | methyl-2-[(aminosulfonyl)methyl]benzoate  |                             | 419-010-5 | —           | Xn; R22<br>Xi; R36                        | Xn<br>R: 22-36<br>S: (2-)22-26                         |                      |                               |
| 607-439-00-2 | methyl tetrahydro-2-furancarboxylate  |                             | 420-670-1 | 37443-42-8  | Xi; R41                                   | Xi<br>R: 41<br>S: (2-)26-39                            |                      |                               |
| 607-440-00-8 | methyl 2-aminosulfonyl-6-(trifluoromethyl)pyridine-3-carboxylate  |                             | 421-220-7 | 144740-59-0 | R43<br>N; R51-53                          | Xi; N<br>R: 43-51/53<br>S: (2-)22-24-37-61             |                      |                               |
| 607-441-00-3 | 3-[3-(2-dodecyloxy-5-methylphenyl)carbamoyl]-4-hydroxy-1-naphthylthio]propionic acid  |                             | 421-490-6 | 167684-63-1 | R53                                       | R: 53<br>S: 57-61                                      |                      |                               |

| Index No     | chemical name  | Notes related to substances | EC No     | CAS No      | Classification | Labelling                               | Concentration Limits | Notes related to preparations |
|--------------|--|-----------------------------|-----------|-------------|----------------|---|----------------------|-------------------------------|
| 607-442-00-9 | benzyl [hydroxy-(4-phenylbutyl)phosphinyl] acetate   |                             | 416-050-5 | 87460-09-1  | Xi; R41        | Xi<br>R: 41<br>S: (2-)26-36/39          |                      |                               |
| 607-443-00-4 | bis(2,4-di-tert-butyl-6-methylphenyl)ethyl phosphate   |                             | 416-140-4 | 145650-60-8 | R 53           | R: 53<br>S: 61                          |                      |                               |
| 607-444-00-X | A mixture of: cis-1,4-dimethylcyclohexyl dibenzoate<br>trans-1,4-dimethylcyclohexyl dibenzoate |                             | 416-230-3 | 35541-81-2  | R 53           | R: 53<br>S: 61                          |                      |                               |
| 607-445-00-5 | Iron (III) tris(4-methylbenzenesulfonate)  |                             | 420-960-8 | 77214-82-5  | Xi; R41        | Xi<br>R: 41<br>S: (2-)24-26-39          |                      |                               |
| 607-446-00-0 | methyl 2-[4-(2-chloro-4-nitrophenylazo)-3-(1-oxopropylamino)]phenylaminopropionate             |                             | 416-240-8 | 155522-12-6 | R 43<br>R 53   | Xi<br>R: 43-53<br>S: (2-)22-24-37-61    |                      |                               |
| 607-447-00-6 | sodium 4-[4-(4-hydroxyphenylazo)phenylamino]-3-nitrobenzenesulfonate                           |                             | 416-370-5 | 156738-27-1 | R 43<br>R52-53 | Xi<br>R: 43-52/53<br>S: (2-)22-24-37-61 |                      |                               |
| 607-448-00-1 | 2,3,5,6-tetrafluorobenzoic acid  |                             | 416-800-1 | 652-18-6    | Xi; R38-41     | Xi<br>R: 38-41<br>S: (2-)22-26-37/39    |                      |                               |

| Index No     | chemical name   | Notes related to substances | EC No     | CAS No      | Classification            | Labelling  | Concentration Limits | Notes related to preparations |
|--------------|---|-----------------------------|-----------|-------------|---------------------------|--|----------------------|-------------------------------|
| 607-449-00-7 | A mixture of: 4,4',4''-[2,4,6-trioxo-1,3,5(2H,4H,6H)-triazine-1,3,5-triyl]tris[methylene(3,5,5-trimethyl-3,1-cyclohexanediyl)iminocarbonyloxy-2,1-ethanediyl(ethylamino)]trisbenzenediazoniumtri[bis(2-methylpropyl)naphthalenesulfonate]<br>4,4',4'',4'''-[5,5'-[carbonylbis[imino(1,5,5-trimethyl-3,1-cyclohexanediyl)methylene]]-2,4,6-trioxo-1,3,5(2H,4H,6H)-triazine-1,1',3,3'-tetrayl]tetrakis[methylene(3,5,5-trimethyl-3,1-cyclohexanediyl)iminocarbonyloxy-2,1-ethanediyl(ethylamino)]tetrakisbenzenediazoniumtetra[bis(2-methylpropyl)naphthalenesulfonate] |                             | 417-080-1 | —           | E; R2<br>R43<br>N; R50-53 | E; Xi; N<br>R: 2-43-50/53<br>S: (2-)24-35-37-60-61 |                      |                               |
| 607-450-00-2 | 2-mercaptobenzothiazolyl-(Z)-(2-aminothiazol-4-yl)-2-(tert-butoxycarbonyl) isopropoxyiminoacetate   |                             | 419-040-9 | 89604-92-2  | R 53                      | R: 53<br>S: 61                                     |                      |                               |
| 607-451-00-8 | 4-[4-amino-5-hydroxy-3-(4-(2-sulfoxyethylsulfonyl)phenylazo)-2,7-disulfonapht-6-ylazo]-6-[3-(4-amino-5-hydroxy-3-(4-(2-sulfoxyethylsulfonyl)phenylazo)-2,7-disulfonapht-6-ylazo)phenylcarbonylamino]benzenesulfonic acid, sodium salt   |                             | 417-640-5 | 161935-19-9 | Xi; R41<br>R43            | Xi<br>R: 41-43<br>S: (2-)22-24-26-37/39            |                      |                               |
| 607-453-00-9 | 4-benzyl-2,6-dihydroxy-4-azahexyloxy bis(2,2-dimethyloctanoate)   |                             | 418-100-1 | 172964-15-7 | R 43<br>R 53              | Xi<br>R: 43-53<br>S: (2-)24-37-61                  |                      |                               |

| Index No     | chemical name   | Notes related to substances | EC No     | CAS No      | Classification       | Labelling                               | Concentration Limits | Notes related to preparations |
|--------------|---|-----------------------------|-----------|-------------|----------------------|---|----------------------|-------------------------------|
| 607-454-00-4 | A mixture of: trans-2-(1-methylethyl)-1,3-dioxane-5-carboxylic acid;<br>cis-2-(1-methylethyl)-1,3-dioxane-5-carboxylic acid   |                             | 418-170-3 | —           | Xi; R41<br>R52-53    | Xi<br>R: 41-52/53<br>S: (2-)25-26-39-61 |                      |                               |
| 607-455-00-X | 1-amino-4-(3-[4-chloro-6-(2,5-di-sulfophenylamino)-1,3,5-triazin-2-ylamino]-2,2-dimethylpropylamino)-anthraquinone-2-sulfonic acid, na/li salt  |                             | 419-520-8 | 172890-93-6 | R 43                 | Xi<br>R: 43<br>S: (2-)22-24-37          |                      |                               |
| 607-456-00-5 | 3-amino-4-chlorobenzoic acid, hexadecyl ester   |                             | 419-700-6 | 143269-74-3 | N; R51-53            | N<br>R: 51/53<br>S: 61                  |                      |                               |
| 607-457-00-0 | tetrasodium dihydrogen 1,1''-dihydroxy-8,8''-[p-phenylbis(imino-{6-[4-(2-aminoethyl)piperazin-1-yl]})-1,3,5-triazine-4,2-diyl-imino]]bis(2,2'-azonaphthalene-1',3,6-trisulfonate)   |                             | 420-350-1 | 172277-97-3 | Xi; R41<br>N; R51-53 | Xi; N<br>R: 41-51/53<br>S: (2-)26-39-61 |                      |                               |
| 607-458-00-6 | A mixture of: 2-ethyl-[2,6-dibromo-4-[1-[3,5-dibromo-4-(2-hydroxyethoxy)phenyl]-1-methylethyl]phenoxy]propenoate<br>2,2'-diethyl-[4,4'-bis(2,6-dibromophenoxy)-1-methylethylidene]dipropenoate<br>2,2'-[(1-methylethylidene)-bis[[2,6-dibromo-4,1-phenylene)oxy]ethanol]] |                             | 420-850-1 | —           | N; R51-53            | N<br>R: 51/53<br>S: 61                  |                      |                               |

| Index No     | chemical name   | Notes related to substances | EC No     | CAS No     | Classification                        | Labelling   | Concentration Limits | Notes related to preparations |
|--------------|---|-----------------------------|-----------|------------|---------------------------------------|---|----------------------|-------------------------------|
| 607-459-00-1 | isopentyl 4-{2-[5-cyano-1,2,3,6-tetrahydro-1-(2-isopropoxy-yethoxy-carbonylmethyl)-4-methyl-2,6-dioxo-3-pyridylidene]hydrazino}benzoate   |                             | 418-930-4 | —          | R 53                                  | R: 53<br>S: 61  |                      |                               |
| 607-460-00-7 | 3-tridecyloxy-propyl-ammonium 9-octadecenoate   |                             | 418-990-1 | —          | Xn; R48/22<br>Xi; R36/38<br>N; R50-53 | Xn; N<br>R: 36/38-48/22-50/53<br>S: (2-)23-26-37/39-60-61 |                      |                               |
| 607-461-00-2 | A mixture of: pentasodium 2-{4-{3-methyl-4-[6-sulfonato-4-(2-sulfonato-phenylazo)-naphthalen-1-ylazo]-phenylamino}-6-[3-(2-sulfato-ethanesulfonyl)-phenylamino]-1,3,5-triazin-2-ylamino}-benzene-1,4-disulfonate pentasodium 2-{4-{3-methyl-4-[7-sulfonato-4-(2-sulfonato-phenylazo)-naphthalen-1-ylazo]-phenylamino}-6-[3-(2-sulfato-ethanesulfonyl)-phenylamino]-1,3,5-triazin-2-ylamino}-benzene-1,4-disulfonate |                             | 421-160-1 | —          | R 52-53                               | R: 52/53<br>S: 61   |                      |                               |
| 607-462-00-8 | A mixture of: 1-hexyl acetate<br>2-methyl-1-pentyl acetate<br>3-methyl-1-pentyl acetate;<br>4-methyl-1-pentyl acetate<br>other mixed linear and branched C6-alkyl acetates  |                             | 421-230-1 | 88230-35-7 | N; R51-53                             | N<br>R: 51/53<br>S: 61                                    |                      |                               |

| Index No     | chemical name  | Notes related to substances | EC No     | CAS No     | Classification                          | Labelling  | Concentration Limits | Notes related to preparations |
|--------------|--|-----------------------------|-----------|------------|---|--|----------------------|-------------------------------|
| 607-463-00-3 | 3-(phenothiazin-10-yl)propionic acid   |                             | 421-260-5 | 362-03-8   | N; R51-53                               | N<br>R: 51/53<br>S: 24/25-61                                     |                      |                               |
| 607-464-00-9 | A mixture of: 7-chloro-1-ethyl-6-fluoro-1,4-dihydro-4-oxo-quinoline-3-carboxylic acid<br>5-chloro-1-ethyl-6-fluoro-1,4-dihydro-4-oxo-quinoline-3-carboxylic acid   |                             | 421-280-4 | 68077-26-9 | R 52-53                                 | R: 52/53<br>S: 61  |                      |                               |
| 607-465-00-4 | tris(2-hydroxyethyl)ammonium 7-{4-[4-(2-cyanoamino-4-hydroxy-6-oxidopyrimidin-5-ylazo)benzamido]-2-ethoxy-phenylazo}naphthalene-1,3-disulfonate  |                             | 421-440-3 | —          | R 52-53                                 | R: 52/53<br>S: 61  |                      |                               |
| 607-466-00-X | A mixture of: phenyl 1-(1-[2-chloro-5-(hexadecyloxy-carbonyl)-phenylcarbamoyl]-3,3-dimethyl-2-oxobutyl)-1H-2,3,3a,7a-tetrahydrobenzotriazole-5-carboxylate<br>phenyl 2-(1-(2-chloro-5-(hexadecyloxy-carbonyl)-phenylcarbamoyl)-3,3-dimethyl-2-oxobutyl)-1H-2,3,3a,7a-tetrahydrobenzotriazole-5-carboxylate<br>phenyl 3-(1-(2-chloro-5-(hexadecyloxy-carbonyl)-phenylcarbamoyl)-3,3-dimethyl-2-oxobutyl)-1H-2,3,3a,7a-tetrahydrobenzotriazole-5-carboxylate |                             | 421-480-1 | —          | N; R51-53                               | N<br>R: 51/53<br>S: 37/39-61                                     |                      |                               |
| 607-467-00-5 | 1,1,3,3-tetrabutyl-1,3-ditinoxid-caprylate   |                             | 419-430-9 | 56533-00-7 | Xn; R21/22-48/22<br>C; R34<br>N; R50-53 | C; N<br>R: 21/22-34-48/22-50/53<br>S: (1/2-)26-36/37/39-45-60-61 |                      |                               |



| Index No     | chemical name  | Notes related to substances | EC No     | CAS No      | Classification    | Labelling                               | Concentration Limits | Notes related to preparations |
|--------------|--|-----------------------------|-----------|-------------|-------------------|---|----------------------|-------------------------------|
| 607-468-00-0 | A mixture of: monosodium 4-((4-(5-sulfonato-2-methoxyphenylamino)-6-chloro-1,3,5-triazine-2-yl)amino)-2-((1,4-dimethyl-6-oxido-2-oxo-5-sulfonatomethyl-1,2-dihydropyridine-3-yl)azo)benzenesulfonate<br>disodium 4-((4-(5-sulfonato-2-methoxyphenylamino)-6-chloro-1,3,5-triazine-2-yl)amino)-2-((1,4-dimethyl-6-oxido-2-oxo-5-sulfonatomethyl-1,2-dihydropyridine-3-yl)azo)benzenesulfonate<br>trisodium 4-((4-(5-sulfonato-2-methoxyphenylamino)-6-chloro-1,3,5-triazine-2-yl)amino)-2-((1,4-dimethyl-6-oxido-2-oxo-5-sulfonatomethyl-1,2-dihydropyridine-3-yl)azo)benzenesulfonate<br>tetrasodium 4-((4-(5-sulfonato-2-methoxyphenylamino)-6-chloro-1,3,5-triazine-2-yl)amino)-2-((1,4-dimethyl-6-oxido-2-oxo-5-sulfonatomethyl-1,2-dihydropyridine-3-yl)azo)benzenesulfonate |                             | 419-450-8 | —           | R43               | Xi<br>R: 43<br>S: (2-)22-24-37          |                      |                               |
| 607-469-00-6 | disodium 7-((4,6-bis(3-diethylaminopropylamino)-1,3,5-triazine-2-yl)amino)-4-hydroxy-3-(4-(4-sulfonatophenylazo)phenylazo)-2-naphthalene sulfonate   |                             | 419-460-2 | 120029-06-3 | R52-53            | R: 52/53<br>S: 61                       |                      |                               |
| 607-470-00-1 | potassium sodium 6,13-dichloro-3,10-bis{2-[4-[3-(2-hydroxysulphonyloxyethanesulfonyl)phenylamino]-6-(2,5-disulfonatophenylamino)-1,3,5-triazin-2-ylamino]ethylamino}benzo[5,6][1,4]oxazino[2,3-b]phenoxazine-4,11-disulfonate  |                             | 414-100-0 | —           | Xi; R41<br>R52-53 | Xi<br>R: 41-52/53<br>S: (2-)39-22-26-61 |                      |                               |

| Index No     | chemical name   | Notes related to substances | EC No     | CAS No      | Classification                         | Labelling                                      | Concentration Limits | Notes related to preparations |
|--------------|---|-----------------------------|-----------|-------------|--|--|----------------------|-------------------------------|
| 607-472-00-2 | ammonium iron(III) trimethylenediaminetetraacetate hemihydrate  |                             | 400-660-3 | 111687-36-6 | N; R51-53                              | N<br>R: 51/53<br>S: 61                         |                      |                               |
| 607-474-00-3 | (4-(4-(4-dimethylaminobenzylidene-1-yl)-3-methyl-5-oxo-2-pyrazolin-1-yl)benzoic acid  |                             | 410-430-4 | 117573-89-4 | R53                                    | R: 53<br>S: 61                                 |                      |                               |
| 607-475-00-9 | A mixture (50/50) of:<br>tetrasodium 7-(4-[4-chloro-6-[methyl-(3-sulfonatophenyl)amino]-1,3,5-triazin-2-ylamino]-2-ureidophenylazo)naphthalene-1,3,6-trisulfonate<br>tetrasodium 7-(4-[4-chloro-6-[methyl-(4-sulfonatophenyl)amino]-1,3,5-triazin-2-ylamino]-2-ureidophenylazo)naphthalene-1,3,6-trisulfonate |                             | 412-940-2 | 148878-18-6 | R43                                    | Xi<br>R: 43<br>S: (2-)22-24-37                 |                      |                               |
| 607-476-00-4 | trisodium N,N-bis(carboxymethyl)-β-alanine  |                             | 414-070-9 | 129050-62-0 | C; R34<br>R52-53                       | C<br>R: 34-52/53<br>S: (1/2-)26-36/37/39-45-61 |                      |                               |
| 607-478-00-5 | tetramethylammonium hydrogen phthalate  |                             | 416-900-5 | 79723-02-7  | T; R25<br>Xn; R48/22<br>N; R50         | T; N<br>R: 25-48/22-50<br>S: (1/2-)25-36-45-61 |                      |                               |
| 607-479-00-0 | hexadecyl 4-chloro-3-[2-(5,5-dimethyl-2,4-dioxo-1,3-oxazolidin-3-yl)-4,4-dimethyl-3-oxopen-tamido]benzoate  |                             | 418-550-9 | 168689-49-4 | R53                                    | R: 53<br>S: 61                                 |                      |                               |
| 607-480-00-6 | 1,2-benzenedicarboxylic acid di-C7-11-branched and linear alkylesters   |                             | 271-084-6 | 68515-42-4  | Repr. Cat. 2; R61<br>Repr. Cat. 3; R62 | T<br>R: 61-62<br>S: 53-45                      |                      |                               |

| Index No     | chemical name   | Notes related to substances | EC No     | CAS No      | Classification            | Labelling                            | Concentration Limits | Notes related to preparations |
|--------------|---|-----------------------------|-----------|-------------|---------------------------|--------------------------------------|----------------------|-------------------------------|
| 607-487-00-4 | A mixture of: disodium 4-(3-ethoxycarbonyl-4-(5-(3-ethoxycarbonyl-5-hydroxy-1-(4-sulfonatophenyl)pyrazol-4-yl)penta-2,4-dienylidene)-4,5-dihydro-5-oxopyrazol-1-yl)benzenesulfonate<br>trisodium 4-(3-ethoxycarbonyl-4-(5-(3-ethoxycarbonyl-5-oxido-1-(4-sulfonatophenyl)pyrazol-4-yl)penta-2,4-dienylidene)-4,5-dihydro-5-oxopyrazol-1-yl)benzenesulfonate |                             | 402-660-9 | —           | Repr.Cat.2; R61<br>R52-53 | T<br>R: 61-52/53<br>S: 53-45-61      |                      |                               |
| 607-488-00-X | ethyl (2-acetylamino-5-fluoro-4-isothiocyanatophenoxy)acetate   |                             | 414-210-9 | 147379-38-2 | N; R50-53                 | N<br>R: 50/53<br>S: 60-61            |                      |                               |
| 607-489-00-5 | A mixture of: 2-ethylhexyl linolenate, linoleate and oleate<br>2-ethylhexyl epoxyoleate<br>2-ethylhexyl diepoxylinoleate<br>2-ethylhexyl triepoxylinolenate   |                             | 414-890-7 | 71302-79-9  | R43                       | Xi<br>R: 43<br>S: (2-)24-37          |                      |                               |
| 607-490-00-0 | N-[2-hydroxy-3-(C12-16-alkyloxy)propyl]-N-methyl glycinate  |                             | 415-060-7 | —           | Xi; R41<br>R43            | Xi<br>R: 41-43<br>S: (2-)24-26-37/39 |                      |                               |
| 607-492-00-1 | 2-(1-(3',3'-dimethyl-1'-cyclohexyl)ethoxy)-2-methyl propyl propanoate   |                             | 415-490-5 | 141773-73-1 | N; R51-53                 | N<br>R: 51/53<br>S: 61               |                      |                               |
| 607-493-00-7 | methyl (3aR,4R,7aR)-2-methyl-4-(1S,2R,3-triacetoxypropyl)-3a,7a-dihydro-4H-pyrano[3,4-d]oxazole-6-carboxylate   |                             | 415-670-3 | 78850-37-0  | Xi; R41                   | Xi<br>R: 41<br>S: (2-)26-39          |                      |                               |
| 607-494-00-2 | bis(2-ethylhexyl)octylphosphonate   |                             | 417-170-0 | 52894-02-7  | N; R50-53                 | N<br>R: 50/53<br>S: 60-61            |                      |                               |

| Index No     | chemical name   | Notes related to substances | EC No     | CAS No      | Classification                 | Labelling  | Concentration Limits | Notes related to preparations |
|--------------|---|-----------------------------|-----------|-------------|--------------------------------|--|----------------------|-------------------------------|
| 607-495-00-8 | sodium 4-sulfophenyl-6-((1-oxononyl)amino)hexanoate                               |                             | 417-550-6 | 168151-92-6 | R43                            | Xi<br>R: 43<br>S: (2-)24-37                          |                      |                               |
| 607-496-00-3 | 2,2'-methylenebis(4,6-di-tert-butyl-phenyl)-2-ethylhexyl phosphite                |                             | 418-310-3 | 126050-54-2 | R53                            | R: 53<br>S: 61                                       |                      |                               |
| 607-497-00-9 | cerium oxide isostearate  |                             | 419-760-3 | —           | R53                            | R: 53<br>S: 61                                       |                      |                               |
| 607-498-00-4 | (E)-3,7-dimethyl-2,6-octadienyl-hexadecanoate                                     |                             | 421-370-3 | 3681-73-0   | Xi; R38<br>R53                 | Xi<br>R: 38-53<br>S: (2-)37-61                       |                      |                               |
| 607-499-00-X | bis(dimethyl-(2-hydroxyethyl)ammonium) 1,2-ethanediyl-bis(2-hexadecenylsuccinate) |                             | 421-660-1 | —           | Xi; R41<br>R43<br>N; R51-53    | Xi; N<br>R: 41-43-51/53<br>S: (2-)24-26-37/39-61     |                      |                               |
| 607-500-00-3 | calcium 2,2,bis[(5-tetrapropylene-2-hydroxy)phenyl]ethanoate                      |                             | 421-670-4 | —           | Xi; R38<br>N; R50-53           | Xi; N<br>R: 38-50/53<br>S: (2-)37-60-61              |                      |                               |
| 607-501-00-9 | A mixture of: triphenylthiophosphate and tertiary butylated phenyl derivatives    |                             | 421-820-9 | —           | R53                            | R: 53<br>S: 61                                       |                      |                               |
| 607-502-00-4 | (N-benzyl-N,N,N-tributyl)ammonium 4-dodecylbenzenesulfonate                       |                             | 422-200-0 | —           | C; R34<br>Xn; R22<br>N; R51-53 | C; N<br>R: 22-34-51/53<br>S: (1/2-)26-36/37/39-45-61 |                      |                               |
| 607-503-00-X | 2,4,6-tri-n-propyl-2,4,6-trioxo-1,3,5,2,4,6-trioxatriphosphorinane                |                             | 422-210-5 | 68957-94-8  | C; R34                         | C<br>R: 34<br>S: (1/2-)26-36/37/39-45                |                      |                               |

| Index No     | chemical name   | Notes related to substances | EC No     | CAS No      | Classification | Labelling                      | Concentration Limits | Notes related to preparations |
|--------------|---|-----------------------------|-----------|-------------|----------------|--------------------------------|----------------------|-------------------------------|
| 607-505-00-0 | pentasodium 7-(4-(4-(5-amino-4-sulfonato-2-(4-((2-(sulfonatoethoxy)sulfonyl)phenylazo)phenylamino)-6-chloro-1,3,5-triazin-2-yl)amino-2-ureidophenylazo)naphthalene-1,3,6-trisulfonate   |                             | 422-930-1 | 171599-84-1 | R52-53         | R: 52/53<br>S: 22-61           |                      |                               |
| 607-506-00-6 | A mixture of: strontium (4-chloro-2-((4,5-dihydro-3-methyl-5-oxo-1-(3-sulfonatophenyl)-1H-pyrazol-4-yl)azo)-5-methyl)benzenesulfonate<br>disodium (4-chloro-2-((4,5-dihydro-3-methyl-5-oxo-1-(3-sulfonatophenyl)-1H-pyrazol-4-yl)azo)-5-methyl)benzenesulfonate |                             | 422-970-8 | 136248-04-9 | N; R51-53      | N<br>R: 51/53<br>S: 22-61      |                      |                               |
| 607-507-00-1 | potassium,sodium 2,4-diamino-3-[4-(2-sulfonatoethoxysulfonyl)phenylazo]-5-[4-(2-sulfonatoethoxysulfonyl)-2-sulfonato-phenylazo]-benzenesulfonate  |                             | 422-980-2 | 187026-95-5 | Xi; R41        | Xi<br>R: 41<br>S: (2-)22-26-39 |                      |                               |
| 607-508-00-7 | disodium 3,3'-[iminobis(sulfonyl-4,1-phenylene-(5-hydroxy-3-methylpyrazole-1,4-diyl)azo-4,1-phenylene-sulfonylimino-(4-amino-6-hydroxypyrimidine-2,5-diyl)azo-4,1-phenylenesulfonylimino(4-amino-6-hydroxypyrimidine-2,5-diyl)azo]bis(benzenesulfonate)]        |                             | 423-110-4 | —           | Xi; R41        | Xi<br>R: 41<br>S: (2-)22-26-39 |                      |                               |
| 607-512-00-9 | trisodium 2,4-diamino-3,5-bis-[4-(2-sulfonatoethoxy)sulfonyl)phenylazo]benzenesulfonate   |                             | 423-970-0 | 182926-43-8 | R52-53         | R: 52/53<br>S: 22-61           |                      |                               |

| Index No     | chemical name   | Notes related to substances | EC No     | CAS No      | Classification            | Labelling                                    | Concentration Limits | Notes related to preparations |
|--------------|---|-----------------------------|-----------|-------------|---------------------------|--|----------------------|-------------------------------|
| 607-513-00-4 | A mixture of: Trisodium 4-benzoylamino-6-(6-ethenesulfonyl-1-sulfato-naphthalen-2-ylazo)-5-hydroxynaphthalene-2,7-disulfonate<br>5-(benzoylamino)-4-hydroxy-3-((1-sulfo-6-((2-(sulfooxy)ethyl)sulfonyl)-2-naphthyl)azo)naphthalene-2,7-disulfonic acid sodium salt<br>5-(benzoylamino)-4-hydroxy-3-((1-sulfo-6-((2-(sulfooxy)ethyl)sulfonyl)-2-naphthyl)azo)naphthalene-2,7-disulfonic acid |                             | 423-200-3 | —           | Xi; R41<br>R43<br>R52-53  | Xi<br>R: 41-43-52/53<br>S: 22-26-36/37/39-61 |                      |                               |
| 607-515-00-5 | A mixture of: disodium hexyldiphenyl ether disulphonate<br>disodium dihexyldiphenyl ether disulphonate  |                             | 429-650-7 | 147732-60-3 | Xi; R36<br>N; R51-53      | Xi; N<br>R: 36-51/53<br>S: (2-)26-61         |                      |                               |
| 607-516-00-0 | N,N'-bis(trifluoroacetyl)-S,S'-bis-L-homocysteine   |                             | 429-670-6 | 105996-54-1 | Xi; R41<br>R43            | Xi<br>R: 41-43<br>S: (2-)24-26-37/39         |                      |                               |
| 607-517-00-6 | (S)- $\alpha$ -(acetylthio)benzenepropanoic acid  |                             | 430-300-0 | 76932-17-7  | Xn; R22<br>Xi; R41<br>R43 | Xn<br>R: 22-41-43<br>S: (2-)22-26-36/37/39   |                      |                               |
| 607-526-00-5 | cartap<br>1,3-bis(carbamoylthio)-2-(dimethylamino)propane   |                             | —         | 15263-53-3  | N; R50-53                 | N<br>R: 50/53<br>S: 60-61                    |                      |                               |

| Index No     | chemical name   | Notes related to substances | EC No     | CAS No      | Classification                 | Labelling  | Concentration Limits | Notes related to preparations |
|--------------|---|-----------------------------|-----------|-------------|--------------------------------|--|----------------------|-------------------------------|
| 607-527-00-0 | A mixture of: 1-(1'H,1'H,2'H,2'H-tridecafluorooctyl)-12-(1''H,1''H,2''H,2''H-tridecafluorooctyl)dodecanedioate<br>1-(1'H,1'H,2'H,2'H-tridecafluorooctyl)-12-(1''H,1''H,2''H,2''H-heptdecafluorodecyl)dodecanedioate<br>1-(1'H,1'H,2'H,2'H-tridecafluorooctyl)-12-(1''H,1''H,2''H,2''H-heneicosafuorododecyl)dodecanedioate<br>1-(1'H,1'H,2'H,2'H-tridecafluorooctyl)-12-(1''H,1''H,2''H,2''H-pentacosafuorotetradecyl)dodecanedioate<br>1-(1'H,1'H,2'H,2'H-heptadecafluorodecyl)-12-(1''H,1''H,2''H,2''H-heptadecafluorodecyl)dodecanedioate<br>1-(1'H,1'H,2'H,2'H-heptadecafluorodecyl)-12-(1''H,1''H,2''H,2''H-heneicosafuorododecyl)dodecanedioate |                             | 423-180-6 | —           | Xn; R48/22                     | Xn<br>R: 48/22<br>S: (2-)36                          |                      |                               |
| 608-031-00-7 | 2-benzyl-2-methyl-3-butenitrile   |                             | 407-870-4 | 97384-48-0  | Xn; R22<br>R 52-53             | Xn<br>R: 22-52/53<br>S: (2-)61                       |                      |                               |
| 608-033-00-8 | N-butyl-3-(2-chloro-4-nitrophenylhydrazono)-1-cyano-2-methylprop-1-ene-1,3-dicarboximide  |                             | 407-970-8 | 75511-91-0  | R 43<br>R 52-53                | Xi<br>R: 43-52/53<br>S: (2-)24-37-61                 |                      |                               |
| 608-034-00-3 | chlorfenapyr<br>4-bromo-2-(4-chlorophenyl)-1-ethoxymethyl-5-trifluoromethylpyrrole-3-carbonitrile   |                             | —         | 122453-73-0 | T; R23<br>Xn; R22<br>N; R50-53 | T; N<br>R: 22-23-50/53<br>S: (1/2-)13-36/37-45-60-61 |                      |                               |
| 608-035-00-9 | (+/-)- $\alpha$ -[(2-acetyl-5-methylphenyl)-amino]-2,6-dichlorobenzene-aceto-nitrile  |                             | 419-290-9 | —           | R43<br>R53                     | Xi<br>R: 43-53<br>S: (2-)24-37-61                    |                      |                               |

| Index No     | chemical name  | Notes related to substances | EC No     | CAS No      | Classification                 | Labelling  | Concentration Limits | Notes related to preparations |
|--------------|--|-----------------------------|-----------|-------------|--------------------------------|--|----------------------|-------------------------------|
| 608-036-00-4 | 3-(2-[4-[2-(4-cyanophenyl)vinyl]-phenyl]vinyl)benzotrile   |                             | 419-060-8 | 79026-02-1  | R 53                           | R: 53<br>S: 61                                       |                      |                               |
| 608-037-00-X | A mixture of: (E)-2,12-tridecadiennitrile<br>(E)-3,12-tridecadiennitrile<br>(Z)-3,12-tridecadiennitrile  |                             | 422-190-8 | 124071-40-5 | N; R50-53                      | N<br>R: 50/53<br>S: 60-61                            |                      |                               |
| 608-038-00-5 | 2,2,4-trimethyl-4-phenyl-butane-nitrile  |                             | 422-580-8 | 75490-39-0  | Xn; R22<br>N; R51-53           | Xn; N<br>R: 22-51/53<br>S: (2-)61                    |                      |                               |
| 608-039-00-0 | 2-phenylhexanenitrile  |                             | 423-460-8 | 3508-98-3   | Xn; R22<br>N; R50-53           | Xn; N<br>R: 22-50/53<br>S: (2-)23-60-61              |                      |                               |
| 608-040-00-6 | 4,4'-dithiobis(5-amino-1-(2,6-dichloro-4-(trifluoromethyl)phenyl)-1H-pyrazole-3-carbonitrile)  |                             | 423-490-1 | 130755-46-3 | N; R50-53                      | N<br>R: 50/53<br>S: 60-61                            |                      |                               |
| 608-041-00-1 | 4'-((2-butyl-4-oxo-1,3-diazaspiro[4.4]non-1-ene-3-yl)methyl)(1,1'-biphenyl)-2-carbonitrile   |                             | 423-500-4 | 138401-24-8 | N; R50-53                      | N<br>R: 50/53<br>S: 60-61                            |                      |                               |
| 608-043-00-2 | 3-(cis-3-hexenyloxy)propanenitril  |                             | 415-220-6 | 142653-61-0 | T; R23<br>Xn; R22<br>N; R50-53 | T; N<br>R: 22-23-50/53<br>S: (1/2-)13-36/37-45-60-61 |                      |                               |
| 609-064-00-X | mesotrione<br>2-[4-(methylsulfonyl)-2-nitrobenzoyl]-1,3-cyclohexanedione   |                             | —         | 104206-82-8 | N; R50-53                      | N<br>R: 50/53<br>S: 60-61                            |                      |                               |
| 609-066-00-0 | lithium sodium 3-amino-10-(4-(10-amino-6,13-dichloro-4,11-disulfonatobenzo[5,6][1,4]oxazino[2,3-b]phenoxazine-3-ylamino)-6-[methyl(2-sulfonatoethyl)amino]-1,3,5-triazin-2-ylamino)-6,13-dichlorobenzo[5,6][1,4]oxazino[2,3-b]phenoxazine-4,11-disulfonate |                             | 418-870-9 | 154212-58-5 | Xn; R20/21/22-68/20/21/22      | Xn<br>R: 20/21/22-68/20/21/22<br>S: (2-)36/37        |                      |                               |



| Index No     | chemical name   | Notes related to substances | EC No     | CAS No      | Classification                          | Labelling  | Concentration Limits | Notes related to preparations |
|--------------|---|-----------------------------|-----------|-------------|---|--|----------------------|-------------------------------|
| 609-067-00-6 | sodium and potassium 4-(3-aminopropylamino)-2,6-bis[3-(4-methoxy-2-sulfophenylazo)-4-hydroxy-2-sulfo-7-naphthylamino]-1,3,5-triazine                                    |                             | 416-280-6 | 156769-97-0 | R 43                                    | Xi<br>R: 43<br>S: (2-)22-24-37                     |                      |                               |
| 609-068-00-1 | musk xylene<br>5- <i>tert</i> -butyl-2,4,6-trinitro- <i>m</i> -xylene   |                             | 201-329-4 | 81-15-2     | Carc. Cat. 3; R40<br>E; R2<br>N; R50-53 | E; Xn; N<br>R: 2-40-50/53<br>S: (2-)36/37-46-60-61 |                      |                               |
| 609-070-00-2 | 1,4-dichloro-2-(1,1,2,3,3,3-hexafluoropropoxy)-5-nitrobenzene   |                             | 415-580-4 | 130841-23-5 | Xn; R22<br>R 43<br>N; R50-53            | Xn; N<br>R: 22-43-50/53<br>S: (2-)36/37/39-60-61   |                      |                               |
| 609-071-00-8 | A mixture of: 2-methylsulfanyl-4,6-bis-(2-hydroxy-4-methoxyphenyl)-1,3,5-triazine<br>2-(4,6-bis-methylsulfanyl-1,3,5-triazin-2-yl)-5-methoxy-phenol                     |                             | 423-520-3 | 156137-33-6 | R43                                     | Xi<br>R: 43<br>S: (2-)22-24-37                     |                      |                               |
| 611-099-00-0 | (methylenebis(4,1-phenylenazo(1-(3-(dimethylamino)propyl)-1,2-dihydro-6-hydroxy-4-methyl-2-oxopyridine-5,3-diy)))-1,1'-dipyridinium dichloride dihydrochloride          |                             | 401-500-5 | —           | Carc.Cat.2; R45<br>N; R51-53            | T; N<br>R: 45-51/53<br>S: 53-45-61                 |                      |                               |
| 611-100-00-4 | potassium sodium 3,3'-(3(or4)-methyl-1,2-phenylenebis(imino(6-chloro)-1,3,5-triazine-4,2-diylimino(2-acetamido-5-methoxy)-4,1-phenylenazo)dinaphthalene-1,5-disulfonate |                             | 403-810-6 | 140876-13-7 | Xi; R41                                 | Xi<br>R: 41<br>S: (2-)26-39                        |                      |                               |
| 611-101-00-X | 2'-(4-chloro-3-cyano-5-formyl-2-thienyl)azo-5'-diethylaminoacetanilide  |                             | 405-200-5 | 104366-25-8 | R43                                     | Xi<br>R: 43<br>S: (2-)22-24-37                     |                      |                               |
| 611-103-00-0 | trisodium (1-(3-carboxylato-2-oxido-5-sulfonatophenylazo)-5-hydroxy-7-sulfonatophthalen-2-amido)nickel(II)  |                             | 407-110-1 | —           | Xi; R41<br>R 43<br>N; R51-53            | Xi; N<br>R: 41-43-51/53<br>S: (2-)24-26-37/39-61   |                      |                               |

| Index No     | chemical name   | Notes related to substances | EC No     | CAS No      | Classification    | Labelling                                  | Concentration Limits | Notes related to preparations |
|--------------|---|-----------------------------|-----------|-------------|-------------------|--|----------------------|-------------------------------|
| 611-104-00-6 | A mixture of: trisodium (2,4(or 2,6 or 4,6)-bis(3,5-dinitro-2-oxidophenylazo)-5-hydroxyphenolato)(2(or 4or 6)-(3,5-dinitro-2-oxidophenylazo)-5-hydroxy-4(or 2or 6)-(4-(4-nitro-2-sulfonatoanilino)phenylazo)phenolato)ferrate(1-)<br>trisodium bis(2,4(or 2,6 or 4,6)-bis(3,5-dinitro-2-oxidophenylazo)-5-hydroxyphenolato)ferrate(1-)<br>trisodium (2,4(or 2,6 or 4,6)-bis(3,5-dinitro-2-oxidophenylazo)-5-hydroxyphenolato)(2(or 4 or 6)-(3,5-dinitro-2-oxidophenylazo)-5-hydroxy-4(or 2 or 6)-(4-nitro-2-sulfonatophenylazo)phenolato)-ferrate(1-)<br>trisodium (2,4(or 2,6 or 4,6)-bis(3,5-dinitro-2-oxidophenylazo)-5-hydroxyphenolato)(2(or 4 or 6)-(3,5-dinitro-2-oxidophenylazo)-5-hydroxy-4(or 2 or 6)-(3-sulfonatophenylazo)phenolato)-ferrate(1-)<br>disodium 3,3'-(2,4-dihydroxy-1,3(or 1,5 or 3,5)-phenylenediazo)dibenzenesulfonate |                             | 406-870-1 | —           | R 43<br>N; R51-53 | Xi; N<br>R: 43-51/53<br>S: (2-)24-37-61    |                      |                               |
| 611-105-00-1 | sodium 4-(4-chloro-6-(N-ethylanilino)-1,3,5-triazin-2-ylamino)-2-(1-(2-chlorophenyl)-5-hydroxy-3-methyl-1H-pyrazol-4-ylazo)benzenesulfonate   |                             | 407-800-2 | 136213-75-7 | R 43<br>N; R51-53 | Xi; N<br>R: 43-51/53<br>S: (2-)22-24-37-61 |                      |                               |
| 611-106-00-7 | hexasodium 4,4'-dihydroxy-3,3'-bis[2-sulfonato-4-(4-sulfonatophenylazo)phenylazo]-7,7'[p-phenylenebis(imino(6-chloro-1,3,5-triazine-4,2-diyl)imino)]dinaphthalene-2-sulfonate   |                             | 410-180-6 | —           | Xi; R41           | Xi<br>R: 41<br>S: (2-)26-39                |                      |                               |

| Index No     | chemical name   | Notes related to substances | EC No     | CAS No      | Classification    | Labelling                                  | Concentration Limits | Notes related to preparations |
|--------------|---|-----------------------------|-----------|-------------|-------------------|--|----------------------|-------------------------------|
| 611-107-00-2 | potassium sodium 4-(4-chloro-6-(3,6-disulfonato-7-(5,8-disulfonato-naphthalen-2-ylazo)-8-hydroxy-naphthalen-1-ylamino)-1,3,5-triazin-2-ylamino)-5-hydroxy-6-(4-(2-sulfatoethanesulfonyl)-phenylazo)-naphthalene-1,7-disulfonate |                             | 412-490-7 | —           | R 43              | Xi<br>R: 43<br>S: (2-)22-24-37             |                      |                               |
| 611-108-00-8 | disodium 5-((4-((4-chloro-3-sulfonatophenyl)azo)-1-naphthyl)azo)-8-(phenylamino)-1-naphthalenesulfonate   |                             | 413-600-6 | 6527-62-4   | R 52-53           | R: 52/53<br>S: 61                          |                      |                               |
| 611-109-00-3 | Reaction products of: copper(II) sulfate and tetrasodium 2,4-bis[6-(2-methoxy-5-sulfonato-phenylazo)-5-hydroxy-7-sulfonato-2-naphthylamino]-6-(2-hydroxyethylamino)-1,3,5-triazine (2:1)  |                             | 407-710-3 | —           | N; R51-53         | N<br>R: 51/53<br>S: 61                     |                      |                               |
| 611-110-00-9 | tetra-sodium/lithium 4,4'-bis-(8-amino-3,6-disulfonato-1-naphthol-2-ylazo)-3-methylazobenzene   |                             | 408-210-8 | 124605-82-9 | R 43<br>N; R51-53 | Xi; N<br>R: 43-51/53<br>S: (2-)24-28-37-61 |                      |                               |
| 611-111-00-4 | disodium 2-[[4-(2-chloroethylsulfonyl)phenyl]-[(2-hydroxy-5-sulfo-3-[3-[2-(2-sulfooxy)ethylsulfonyl]ethylazo]-4-sulfobenzoato(3-)cuprate(1-)  |                             | 414-230-8 | —           | R 43              | Xi<br>R: 43<br>S: (2-)22-24-37             |                      |                               |

| Index No     | chemical name   | Notes related to substances | EC No     | CAS No      | Classification                | Labelling                                  | Concentration Limits | Notes related to preparations |
|--------------|---|-----------------------------|-----------|-------------|-------------------------------|--|----------------------|-------------------------------|
| 611-112-00-X | tetrasodium 4-hydroxy-5-[4-[3-(2-sulfatoethanesulfonyl)phenylamino]-6-morpholin-4-yl-1,3,5-triazin-2-ylamino]-3-(1-sulfonatophthalen-2-ylazo)naphthalene-2,7-disulfonate  |                             | 413-070-6 | —           | R 43                          | Xi<br>R: 43<br>S: (2-)22-24-37             |                      |                               |
| 611-113-00-5 | lithium sodium (2-(((5-((2,5-dichlorophenyl)azo)-2-hydroxyphenyl)methylene)amino)benzoato(2-)))(2-(((4,5-dihydro-3-methyl-5-oxo-1-phenyl-1H-pyrazol-4-yl)azo)-5-sulfobenzoato(3-)) chromate(2-)                             |                             | 414-280-0 | 149626-00-6 | N; R51-53                     | N<br>R: 51/53<br>S: 24/25-61               |                      |                               |
| 611-114-00-0 | lithium sodium (4-(((5-chloro-2-hydroxyphenyl)azo)-2,4-dihydro-5-methyl-3H-pyrazol-3-onato(2-)))(3-(((4,5-dihydro-3-methyl-1-(4-methylphenyl)-5-oxo-1H-pyrazol-4-yl)azo)-4-hydroxy-5-nitrobenzenesulfonato(3-))chromate(2-) |                             | 414-250-7 | 149564-66-9 | Xn; R22<br>Xi; R41<br>R 52-53 | Xn<br>R: 22-41-52/53<br>S: (2-)22-26-39-61 |                      |                               |
| 611-115-00-6 | trilithium bis(4-((4-(diethylamino)-2-hydroxyphenyl)azo)-3-hydroxy-1-naphthalenesulfonato(3-))chromate(3-)  |                             | 414-290-5 | 149564-65-8 | Xn; R22<br>R 52-53            | Xn<br>R: 22-52/53<br>S: (2-)22-61          |                      |                               |

| Index No     | chemical name  | Notes related to substances | EC No     | CAS No      | Classification  | Labelling                               | Concentration Limits | Notes related to preparations |
|--------------|--|-----------------------------|-----------|-------------|-----------------|---|----------------------|-------------------------------|
| 611-116-00-1 | A mixture of: trisodium 5-(4-chloro-6-[2-(2,6-dichloro-5-cyanopyrimidin-4-ylamino)-propylamino]-1,3,5-triazin-2-ylamino)-4-hydroxy-3-(1-sulfonato-naphthalene-2-ylazo)-naphthalene-2,7-disulfonate<br>trisodium 5-(4-chloro-6-[2-(2,6-dichloro-5-cyanopyrimidin-4-ylamino)-1-methyl-ethylamino]-1,3,5-triazin-2-ylamino)-4-hydroxy-3-(1-sulfonato-naphthalene-2-ylazo)-naphthalene-2,7-disulfonate<br>trisodium 5-(4-chloro-6-[2-(4,6-dichloro-5-cyanopyrimidin-2-ylamino)-propylamino]-1,3,5-triazin-2-ylamino)-4-hydroxy-3-(1-sulfonato-naphthalen-2-ylazo)-naphthalene-2,7-disulfonate<br>trisodium 5-(4-chloro-6-[2-(4,6-dichloro-5-cyanopyrimidin-2-ylamino)-1-methyl-ethylamino]-1,3,5-triazin-2-ylamino)-4-hydroxy-3-(1-sulfonato-naphthalen-2-ylazo)-naphthalene-2,7-disulfonate |                             | 414-620-8 | —           | Xi; R41<br>R 43 | Xi<br>R: 41-43<br>S: (2-)22-24-26-37/39 |                      |                               |
| 611-117-00-7 | 1,3-bis{6-fluoro-4-[1,5-disulfo-4-(3-aminocarbonyl-1-ethyl-6-hydroxy-4-methyl-pyrid-2-on-5-ylazo)-phenyl-2-ylamino]-1,3,5-triazin-2-ylamino}propane lithium-, sodium salt  |                             | 415-100-3 | 149850-29-3 | R 43            | Xi<br>R: 43<br>S: (2-)22-24-37          |                      |                               |
| 611-118-00-2 | sodium 1,2-bis[4-[4-(4-sulfophenylazo)-2-sulfophenylazo]-2-ureido-phenyl-amino]-6-fluoro-1,3,5-triazin-2-ylamino]-propane, sodium salt   |                             | 413-990-8 | 149850-31-7 | R 43            | Xi<br>R: 43<br>S: (2-)22-24-37          |                      |                               |

| Index No     | chemical name  | Notes related to substances | EC No     | CAS No      | Classification       | Labelling                                  | Concentration Limits | Notes related to preparations |
|--------------|--|-----------------------------|-----------|-------------|----------------------|--|----------------------|-------------------------------|
| 611-119-00-8 | tetrasodium 4-[4-chloro-6-(4-methyl-2-sulfophenylamino)-1,3,5-triazin-2-ylamino]-6-(4,5-dimethyl-2-sulfophenylazo)-5-hydroxynaphthalene-2,7-disulfonate  |                             | 415-400-4 | 148878-22-2 | Xi; R41<br>R 43      | Xi<br>R: 41-43<br>S: (2-)22-24-26-37/39    |                      |                               |
| 611-120-00-3 | 5-[4-[5-amino-2-[4-(2-sulfoxyethylsulfonyl)phenylazo]-4-sulfo-phenylamino]-6-chloro-1,3,5-triazin-2-ylamino]-4-hydroxy-3-(1-sulfo-naphthalen-2-ylazo)-naphthalene-2,7-disulfonic acid sodium salt  |                             | 418-340-7 | 157707-94-3 | Xi; R41<br>R 52-53   | Xi<br>R: 41-52/53<br>S: (2-)22-26-39-61    |                      |                               |
| 611-121-00-9 | Main component 6 (isomer):<br>asym. 1:2 Cr(III)-complex of: A: 3-hydroxy-4-(2-hydroxy-naphthalene-1-ylazo)naphthalene-1-sulfonic acid, Na-salt and B: 1-[2-hydroxy-5-(4-methoxyphenylazo)phenylazo]naphthalene-2-ol<br>Main component 8 (isomer):<br>asym. 1:2 Cr-complex of: A: 3-hydroxy-4-(2-hydroxy-naphthalene-1-ylazo)-naphthalene-1-sulfonic acid, Na-salt and B: 1-[2-hydroxy-5-(4-methoxyphenylazo)-phenylazo]-naphthalene-2-ol |                             | 417-280-9 | 30785-74-1  | Xi; R41<br>N; R50-53 | Xi; N<br>R: 41-50/53<br>S: (2-)26-39-60-61 |                      |                               |
| 611-122-00-4 | hexasodium (di[N-(3-(4-[5-(5-amino-3-methyl-1-phenylpyrazol-4-yl-azo)-2,4-disulfanilino]-6-chloro-1,3,5-triazin-2-ylamino)phenyl)-sulfamoyl](disulfo)-phthalocyaninato)nickel  |                             | 417-250-5 | 151436-99-6 | Xi; R41<br>R 43      | Xi<br>R: 41-43<br>S: (2-)22-24-26-37/39    |                      |                               |
| 611-123-00-X | 3-(2,4-bis(4-((5-(4,6-bis(2-aminopropylamino)-1,3,5-triazin-2-ylamino)-4-hydroxy-2,7-disulfonaphthalen-3-yl)azo)phenylamino)-1,3,5-triazin-6-ylamino)-propyldiethylammonium lactate  |                             | 424-310-4 | 178452-66-9 | Xi; R41              | Xi<br>R: 41<br>S: (2-)26-39                |                      |                               |

| Index No     | chemical name   | Notes related to substances | EC No     | CAS No      | Classification       | Labelling                                  | Concentration Limits | Notes related to preparations |
|--------------|---|-----------------------------|-----------|-------------|----------------------|--|----------------------|-------------------------------|
| 611-124-00-5 | A mixture of: pentasodium 5-amino-3-(5-{4-chloro-6-[4-(2-sulfoxyethoxysulfonato)phenylamino]-1,3,5-triazin-2-ylamino]-2-sulfonatophenylazo)-6-[5-(2,3-dibromopropionylamino)-2-sulfonatophenylazo]-4-hydroxynaphthalene-2,7-disulfonate<br>pentasodium 5-amino-6-[5-(2-bromoacryloylamino)-2-sulfonatophenylazo]-3-(5-{4-chloro-6-[4-(2-sulfoxyethoxysulfonato)phenylamino]-1,3,5-triazin-2-ylamino]-2-sulfonatophenylazo)-4-hydroxynaphthalene-2,7-disulfonate<br>tetrasodium 5-amino-3-[5-{4-chloro-6-[4-(vinylsulfonyl)phenylamino]-1,3,5-triazin-2-ylamino]-2-sulfonatophenylazo]-6-[5-(2,3-dibromopropionylamino)-2-sulfonatophenylazo]-4-hydroxynaphthalene-2,7-disulfonate |                             | 424-320-9 | 180778-23-8 | Xi; R41<br>N; R51-53 | Xi; N<br>R: 41-51/53<br>S: (2-)26-39-61    |                      |                               |
| 611-125-00-0 | A mixture of: Disodium 6-[3-carboxy-4,5-dihydro-5-oxo-4-sulfonatophenyl]pyrazolin-4-yl-azo]-3-[2-oxido-4-(ethensulfonyl)-5-methoxyphenylazo]-4-oxidonaphthalene-2-sulfonate copper (II) complex<br>Disodium 6-[3-carboxy-4,5-dihydro-5-oxo-4-sulfonatophenyl]pyrazolin-4-yl-azo]-3-[2-oxido-4-(2-hydroxyethylsulfonyl)-5-methoxyphenylazo]-4-oxidonaphthalene-2-sulfonate copper (II) complex;  |                             | 423-940-7 | —           | Xi; R41<br>N; R51-53 | Xi; N<br>R: 41-51/53<br>S: (2-)26-39-61    |                      |                               |
| 611-126-00-6 | 2,6-bis-(2-(4-(4-amino-phenylamino)-phenylazo)-1,3-dimethyl-3H-imidazolium)-4-dimethylamino-1,3,5-triazine, dichloride  |                             | 424-120-1 | 174514-06-8 | Xi; R41<br>N; R50-53 | Xi; N<br>R: 41-50/53<br>S: (2-)26-39-60-61 |                      |                               |

| Index No     | chemical name  | Notes related to substances | EC No     | CAS No      | Classification  | Labelling   | Concentration Limits | Notes related to preparations |
|--------------|--|-----------------------------|-----------|-------------|---|---|----------------------|-------------------------------|
| 611-127-00-1 | pentasodium 4-amino-6-(5-(4-(2-ethyl-phenylamino)-6-(2-sulfatoethanesulfonyl)-1,3,5-triazin-2-ylamino)-2-sulfonatophenylazo)-5-hydroxy-3-(4-(2-sulfatoethanesulfonyl)phenylazo)naphthalene-2,7-disulfonate   |                             | 423-790-2 | —           | R 5<br>Xi; R41<br>R 43<br>R 52-53                           | Xi<br>R: 5-41-43-52/53<br>S: (2-)22-26-36/37/39-41-61       |                      |                               |
| 611-128-00-7 | N,N'-bis{6-chloro-4-[6-(4-vinylsulfonylphenylazo)-2,7-disulfonacid-5-hydroxynapht-4-ylamino]-1,3,5-triazin-2-yl}-N-(2-hydroxyethyl)ethane-1,2-diamine, sodium salt   |                             | 419-500-9 | 171599-85-2 | Xi; R41<br>R 43   | Xi<br>R: 41-43<br>S: (2-)22-24-26-37/39                     |                      |                               |
| 611-129-00-2 | A mixture of: 5-[(4-[(7-amino-1-hydroxy-3-sulfo-2-naphthyl)azo]-2,5-diethoxyphenyl)azo]-2-[(3-phosphonophenyl)azo]benzoic acid<br>5-[(4-[(7-amino-1-hydroxy-3-sulfo-2-naphthyl)azo]-2,5-diethoxyphenyl)azo]-3-[(3-phosphonophenyl)azo]benzoic acid |                             | 418-230-9 | 163879-69-4 | E; R2<br>Repr.Cat.3; R62<br>Xn; R48/22<br>R 43<br>N; R51-53 | E; Xn; N<br>R: 2-43-48/22-62-51/53<br>S: (2-)26-35-36/37-61 |                      |                               |
| 611-130-00-8 | tetra-ammonium 2-[6-[7-(2-carboxylato-phenylazo)-8-hydroxy-3,6-disulfonato-1-naphthylamino]-4-hydroxy-1,3,5-triazin-2-ylamino]benzoate   |                             | 418-520-5 | 183130-96-3 | Xi; R36<br>N; R50-53  | Xi; N<br>R: 36-50/53<br>S: (2-)26-39-60-61                  |                      |                               |
| 611-131-00-3 | 2-[2-hydroxy-3-(2-chlorophenyl)carbamoyl-1-naphthylazo]-7-[2-hydroxy-3-(3-methylphenyl)carbamoyl-1-naphthylazo]fluoren-9-one   |                             | 420-580-2 | —           | Repr.Cat.2; R61<br>R 53                                     | T<br>R: 61-53<br>S: 53-45-61                                |                      |                               |
| 611-132-00-9 | pentasodium bis{7-[4-(1-butyl-5-cyano-1,2-dihydro-2-hydroxy-4-methyl-6-oxo-3-pyridylazo)phenylsulfonylamino]-5'-nitro-3,3'-disulfonatophthalene-2-azobenzene-1,2'-diolato} chromate (III)  |                             | 419-210-2 | —           | Xi; R41<br>R 52-53  | Xi<br>R: 41-52/53<br>S: (2-)26-39-61                        |                      |                               |



| Index No     | chemical name   | Notes related to substances | EC No     | CAS No | Classification                          | Labelling   | Concentration Limits | Notes related to preparations |
|--------------|---|-----------------------------|-----------|--------|---|---|----------------------|-------------------------------|
| 611-133-00-4 | Product by process iron complex of azo dyestuffs obtained by coupling a mixture of diazotized 2-amino-1-hydroxybenzene-4-sulfanilide and 2-amino-1-hydroxybenzene-4-sulfonamide with resorcin, the obtained mixture being subsequently submitted to a second coupling reaction with a mixture of diazotized 3-aminobenzene-1-sulfonic acid (metanilic acid) and 4'-amino-4-nitro-1,1'-diphenylamine-2-sulfonic acid and metallization with ferric chloride, sodium salt |                             | 419-260-5 | —      | Xi; R41<br>N; R51-53                    | Xi; N<br>R: 41-51/53<br>S: (2-)26-39-61             |                      |                               |
| 611-134-00-X | trisodium 2-{α[2-hydroxy-3-[4-chloro-6-[4-(2,3-dibromopropionylamino)-2-sulfonatophenylamino]-1,3,5-triazin-2-ylamino]-5-sulfonatophenylazo]-benzylidenehydrazino}-4-sulfonato-benzoate, copper complex   |                             | 423-770-3 | —      | Xi; R41<br>N; R51-53                    | Xi; N<br>R: 41-51/53<br>S: (2-)22-26-39-61          |                      |                               |
| 611-135-00-5 | Reaction product of: 2-[[4-amino-2-ureidophenylazo]-5-[(2-(sulfoxy)ethyl)sulfonyl]]benzenesulfonic acid with 2,4,6-trifluoropyrimidine and partial hydrolysis to the corresponding vinylsulfonyl derivative, mixed potassium/sodium salt  |                             | 424-250-9 | —      | Xi; R41<br>R52-53                       | Xi<br>R: 41-52/53<br>S: (2-)26-39-61                |                      |                               |
| 611-136-00-0 | 2-{4-(2-ammoniopropylamino)-6-[4-hydroxy-3-(5-methyl-2-methoxy-4-sulfamoylphenylazo)-2-sulfonatonaphth-7-ylamino]-1,3,5-triazin-2-ylamino}-2-aminopropyl formate  |                             | 424-260-3 | —      | Repr.Cat.3; R62<br>Xi; R41<br>N; R51-53 | Xn; N<br>R: 41-62-51/53<br>S: (2-)22-26-36/37/39-61 |                      |                               |

| Index No     | chemical name   | Notes related to substances | EC No     | CAS No      | Classification   | Labelling   | Concentration Limits  | Notes related to preparations |
|--------------|---|-----------------------------|-----------|-------------|--|---|---|-------------------------------|
| 611-137-00-6 | 6-tert-butyl-7-chloro-3-tridecyl-7,7a-dihydro-1H-pyrazolo[5,1-c]-1,2,4-triazole             |                             | 419-870-1 | 159038-16-1 | R 53   | R: 53<br>S: 61  |   |                               |
| 611-138-00-1 | 2-(4-aminophenyl)-6-tert-butyl-1H-pyrazolo[1,5-b][1,2,4]triazole                            |                             | 415-910-7 | 152828-25-6 | R43<br>N; R51-53   | Xi; N<br>R: 43-51/53<br>S: (2-)22-24-37-61                      |   |                               |
| 611-140-00-2 | azafenidin  |                             | —         | 68049-83-2  | T; R48/22<br>Repr. Cat. 2; R61<br>Repr. Cat. 3; R62<br>N; R50-53 | T; N<br>R: 61-48/22-62-50/53<br>S: 53-45-60-61                  | C ≥ 0.025 %: N; R50/53<br>0.0025 % ≤ C < 0.025 %: N; R51/53<br>0.00025 % ≤ C < 0.0025 %: R52/53 |                               |
| 612-184-00-5 | 6'-(dibutylamino)-3'-methyl-2'-(phenylamino)spiro[isobenzofuran-1(3H),9-(9H)-xanthen]-3-one |                             | 403-830-5 | 89331-94-2  | R 52-53  | R: 52/53<br>S: 61   |   |                               |
| 612-185-00-0 | 1-[3-[4-((heptadecafluorononyloxy)benzamido)propyl]-N,N,N-trimethylammonium iodide          |                             | 407-400-8 | 59493-72-0  | Xi; R41<br>N; R50-53   | Xi; N<br>R: 41-50/53<br>S: (2-)26-39-60-61                      |   |                               |
| 612-186-00-6 | bis(N-(7-hydroxy-8-methyl-5-phenylphenazin-3-ylidene)dimethylammonium) sulfate              |                             | 406-770-8 | 149057-64-7 | Xn; R48/22<br>Xi; R41<br>R 43<br>N; R50-53                       | Xn; N<br>R: 41-43-48/22-50/53<br>S: (2-)22-26-36/37/39-60-61    |   |                               |
| 612-187-00-1 | 2,3,4-trifluoroaniline  |                             | 407-170-9 | 3862-73-5   | Xn; R21/22-48/22<br>Xi; R38-41<br>N; R51-53                      | Xn; N<br>R: 21/22-38-41-48/22-51/53<br>S: (2-)23-26-36/37/39-61 |   |                               |
| 612-188-00-7 | 4,4'-(9H-fluoren-9-ylidene)bis(2-chloroaniline)   |                             | 407-560-9 | 107934-68-9 | N; R51-53  | N<br>R: 51/53<br>S: 61  |   |                               |
| 612-189-00-2 | 4-amino-2-(aminomethyl)phenol dihydrochloride   |                             | 412-510-4 | 135043-64-0 | Xn; R22<br>R 43<br>N; R50-53                                     | Xn; N<br>R: 22-43-50/53<br>S: (2-)22-24-37-60-61                |   |                               |

| Index No     | chemical name  | Notes related to substances | EC No                          | CAS No                         | Classification  | Labelling   | Concentration Limits | Notes related to preparations |
|--------------|--|-----------------------------|--------------------------------|--------------------------------|---|---|----------------------|-------------------------------|
| 612-190-00-8 | 4,4'-methylenebis(2-isopropyl-6-methylaniline)   |                             | 415-150-6                      | 16298-38-7                     | Xn; R48/22<br>N; R51-53   | Xn; N<br>R: 48/22-51/53<br>S: (2-)36-61                       |                      |                               |
| 612-191-00-3 | Polymer of allylamine hydrochloride  |                             | 415-050-2                      | 71550-12-4                     | Xn; R22<br>R 43   | Xn<br>R: 22-43<br>S: (2-)36/37                                |                      |                               |
| 612-192-00-9 | 2-isopropyl-4-(N-methyl)amino-methylthiazole   |                             | 414-800-6                      | 154212-60-9                    | Xn; R21/22<br>Xi; R38-41<br>N; R51-53                           | Xn; N<br>R: 21/22-38-41-51/53<br>S: (2-)26-36/37/39-61        |                      |                               |
| 612-193-00-4 | 3-methylaminomethylphenylamine   |                             | 414-570-7                      | 18759-96-1                     | Xn; R21/22<br>C; R34<br>R 43<br>N; R50-53                       | C; N<br>R: 21/22-34-43-50/53<br>S: (1/2-)26-36/37/39-45-60-61 |                      |                               |
| 612-194-00-X | 2-hydroxy-3-[(2-hydroxyethyl)-[2-(1-oxotetradecyl)amino]ethyl]amino]-N,N,N-trimethyl-1-propanammonium chloride |                             | 414-670-0                      | 141890-30-4                    | Xn; R22<br>Xi; R41<br>N; R50-53                                 | Xn; N<br>R: 22-41-50/53<br>S: (2-)26-39-60-61                 |                      |                               |
| 612-195-00-5 | bis[tributyl 4-(methylbenzyl)ammonium] 1,5-naphthalenedisulfonate  |                             | 415-210-1                      | —                              | Xn; R20/22<br>Xi; R41<br>N; R50-53                              | Xn; N<br>R: 20/22-41-50/53<br>S: (2-)26-36/39-60-61           |                      |                               |
| 612-196-00-0 | 4-chloro- <i>o</i> -toluidine [1]<br>4-chloro- <i>o</i> -toluidine hydrochloride [2]                           | E                           | 202-441-6 [1]<br>221-627-8 [2] | 95-69-2 [1]<br>3165-93-3 [2]   | Carc.Cat.2; R45<br>Muta.Cat.3; R68<br>T; R23/24/25<br>N; R50-53 | T; N<br>R: 45-23/24/25-68-50/53<br>S: 53-45-60-61             |                      |                               |
| 612-197-00-6 | 2,4,5-trimethylaniline [1]<br>2,4,5-trimethylaniline hydrochloride [2]   | E                           | 205-282-0 [1]<br>- [2]         | 137-17-7 [1]<br>21436-97-5 [2] | Carc.Cat.2; R45<br>T; R23/24/25<br>N; R51-53                    | T; N<br>R: 45-23/24/25-51/53<br>S: 53-45-61                   |                      |                               |
| 612-198-00-1 | 4,4'-thiodianiline and its salts   | E                           | 205-370-9                      | 139-65-1                       | Carc.Cat.2; R45<br>Xn; R22<br>N; R51-53                         | T; N<br>R: 45-22-51/53<br>S: 53-45-61                         |                      |                               |

| Index No     | chemical name   | Notes related to substances | EC No                          | CAS No                         | Classification   | Labelling  | Concentration Limits | Notes related to preparations |
|--------------|---|-----------------------------|--------------------------------|--------------------------------|--|--|----------------------|-------------------------------|
| 612-199-00-7 | 4,4'-oxydianiline and its salts<br><i>p</i> -aminophenyl ether  | E                           | 202-977-0                      | 101-80-4                       | Carc.Cat.2; R45<br>Muta.Cat.2; R46<br>Repr.Cat.3; R62<br>T; R23/24/25<br>N; R51-53 | T; N<br>R: 45-46-23/24/25-62-51/53<br>S: 53-45-61                |                      |                               |
| 612-200-00-0 | 2,4-diaminoanisole<br>4-methoxy- <i>m</i> -phenylenediamine [1]<br>2,4-diaminoanisole sulphate [2]                      |                             | 210-406-1 [1]<br>254-323-9 [2] | 615-05-4 [1]<br>39156-41-7 [2] | Carc.Cat.2; R45<br>Muta.Cat.3; R68<br>Xn; R22<br>N; R51-53                         | T; N<br>R: 45-22-68-51/53<br>S: 53-45-61                         |                      |                               |
| 612-201-00-6 | <i>N,N,N',N'</i> -tetramethyl-4,4'-methylendianiline  |                             | 202-959-2                      | 101-61-1                       | Carc.Cat.2; R45<br>N; R50-53   | T; N<br>R: 45-50/53<br>S: 53-45-60-61                            |                      |                               |
| 612-202-00-1 | 3,4-dichloroaniline   |                             | 202-448-4                      | 95-76-1                        | T; R23/24/25<br>Xi; R41<br>R43<br>N; R50-53  | T; N<br>R: 23/24/25-41-43-50/53<br>S: (1/2-)26-36/37/39-45-60-61 |                      |                               |
| 612-204-00-2 | C.I. Basic Violet 3<br>4-[4,4'-bis(dimethylamino)benzhydrylidene]cyclohexa-2,5-dien-1-ylidene]dimethylammonium chloride |                             | 208-953-6                      | 548-62-9                       | Carc.Cat.3; R40<br>Xn; R22<br>Xi; R41<br>N; R50-53                                 | Xn; N<br>R: 22-40-41-50/53<br>S: (2-)26-36/37/39-46-60-61        |                      |                               |
| 612-205-00-8 | C.I. Basic Violet 3 with $\geq 0.1$ % of Michler's ketone (EC no. 202-027-5)  | E                           | 208-953-6                      | 548-62-9                       | Carc.Cat.2; R45<br>Xn; R22<br>Xi; R41<br>N; R50-53                                 | T; N<br>R: 45-22-41-50/53<br>S: 53-45-60-61                      |                      |                               |
| 612-206-00-3 | famoxadone<br>3-anilino-5-methyl-5-(4-phenoxyphenyl)-1,3-oxazolidine-2,4-dione  |                             | —                              | 131807-57-3                    | Xn; R48/22<br>N; R50-53  | Xn; N<br>R: 48/22-50/53<br>S: (2-)46-60-61                       |                      |                               |
| 612-209-00-X | 6-methoxy- <i>m</i> -toluidine<br><i>p</i> -cresidine   | E                           | 204-419-1                      | 120-71-8                       | Carc.Cat.2; R45<br>Xn; R22   | T<br>R: 45-22<br>S: 53-45  |                      |                               |

| Index No     | chemical name   | Notes related to substances | EC No                          | CAS No                        | Classification                               | Labelling   | Concentration Limits | Notes related to preparations |
|--------------|---|-----------------------------|--------------------------------|-------------------------------|--|---|----------------------|-------------------------------|
| 612-210-00-5 | 5-nitro- <i>o</i> -toluidine<br>[1]<br>5-nitro- <i>o</i> -toluidine hydrochloride<br>[2]  |                             | 202-765-8 [1]<br>256-960-8 [2] | 99-55-8 [1]<br>51085-52-0 [2] | Carc.Cat.3; R40<br>T; R23/24/25<br>R52-53    | T<br>R: 23/24/25-40-52/53<br>S: (1/2-)36/37-45-61                 |                      |                               |
| 612-211-00-0 | N-[(benzotriazole-1-yl)methyl]-<br>4-carboxybenzenesulfonamide  |                             | 416-470-9                      | —                             | Xi; R36<br>N; R51-53                         | Xi; N<br>R: 36-51/53<br>S: (2-)26-61                              |                      |                               |
| 612-212-00-6 | 2,6-dichloro-4-trifluoromethyla-<br>niline  |                             | 416-430-0                      | 24279-39-8                    | Xn; R20/22<br>Xi; R38<br>R43<br>N; R50-53    | Xn; N<br>R: 20/22-38-43-50/53<br>S: (2-)24-37-60-61               |                      |                               |
| 612-213-00-1 | isobutylidene-(2-(2-isopropyl-<br>4,4-dimethyloxazolidine-3-yl)-<br>1,1-dimethylethyl)amine   |                             | 419-850-2                      | 148348-13-4                   | C; R34<br>R52-53                             | C<br>R: 34-52/53<br>S: (1/2-)23-26-36/37/39-<br>45-61             |                      |                               |
| 612-214-00-7 | 4-(2,2-diphenylethenyl)-N,N-di-<br>phenylbenzenamine  |                             | 421-390-2                      | 89114-90-9                    | R 53   | R: 53<br>S: 61  |                      |                               |
| 612-215-00-2 | 3-chloro-2-(isopropylthio)aniline   |                             | 421-700-6                      | 179104-32-6                   | Xi; R38<br>N; R51-53                         | Xi; N<br>R: 38-51/53<br>S: (2-)37-61                              |                      |                               |
| 612-217-00-3 | 1-methoxy-2-propylamine   |                             | 422-550-4                      | 37143-54-7                    | F; R11<br>C; R34<br>Xn; R22<br>R52-53        | F; C<br>R: 11-22-34-52/53<br>S: (1/2-)9-26-36/37/39-<br>45-61     |                      |                               |
| 613-181-00-1 | 5,5-dimethyl-perhydro-pyrimi-<br>din-2-one $\alpha$ -(4-<br>trifluoromethylstyryl)- $\alpha$ -(4-tri-<br>fluoromethyl)cinnamylidenehy-<br>drazone |                             | 405-090-9                      | 67485-29-4                    | T; R48/25<br>Xn; R22<br>Xi; R36<br>N; R50-53 | T; N<br>R: 22-36-48/25-50/53<br>S: (1/2-)22-26-36/37-45-<br>60-61 |                      |                               |

| Index No     | chemical name   | Notes related to substances | EC No     | CAS No      | Classification   | Labelling   | Concentration Limits | Notes related to preparations |
|--------------|---|-----------------------------|-----------|-------------|--|---|----------------------|-------------------------------|
| 613-182-00-7 | 1-(1-naphthylmethyl)quinolinium chloride  |                             | 406-220-7 | 65322-65-8  | Carc.Cat.3; R40<br>Muta.Cat.3; R68<br>Xn; R22<br>Xi; R38-41<br>R 52-53 | Xn<br>R: 22-38-40-41-52/53-68<br>S: (2-)22-26-36/37/39-61     |                      |                               |
| 613-183-00-2 | A mixture of: 5-(N-methylperfluorooctylsulfonamido)methyl-3-octadecyl-1,3-oxazolidin-2-one<br>5-(N-methylperfluoroheptylsulfonamido)methyl-3-octadecyl-1,3-oxazolidin-2-one |                             | 413-640-4 | —           | Xn; R48/22<br>N; R50-53  | Xn; N<br>R: 48/22-50/53<br>S: (2-)36-60-61                    |                      |                               |
| 613-184-00-8 | nitrotriethyleneammonio propane-2-ol 2-ethylhexanoate   |                             | 413-670-8 | —           | Xi; R36<br>R 43  | Xi<br>R: 36-43<br>S: (2-)24-26-37                             |                      |                               |
| 613-185-00-3 | 2,3,5,6-tetrahydro-2-methyl-2H-cyclopenta[d]-1,2-thiazol-3-one  |                             | 407-630-9 | 82633-79-2  | T; R25<br>Xi; R41<br>R 43<br>N; R50-53                                 | T; N<br>R: 25-41-43-50/53<br>S: (1/2-)22-26-36/37/39-45-60-61 |                      |                               |
| 613-186-00-9 | (2R,3R)-3-((R)-1-(tert-butyl-dimethylsiloxy)ethyl)-4-oxoazetidin-2-yl acetate   |                             | 408-050-9 | 76855-69-1  | Xi; R36<br>R 43<br>N; R51-53   | Xi; N<br>R: 36-43-51/53<br>S: (2-)24-26-37-61                 |                      |                               |
| 613-188-00-X | 1-(3-(4-fluorophenoxy)propyl)-3-methoxy-4-piperidinone  |                             | 411-500-7 | 116256-11-2 | Xn; R22<br>Xi; R41<br>R 43<br>N; R51-53                                | Xn; N<br>R: 22-41-43-51/53<br>S: (2-)22-24-26-37/39-61        |                      |                               |
| 613-189-00-5 | 1,4,7,10-tetrakis(p-toluensulfonyl)-1,4,7,10-tetraazacyclododecane  |                             | 414-030-0 | 52667-88-6  | R 43<br>N; R50-53  | Xi; N<br>R: 43-50/53<br>S: (2-)24-37-60-61                    |                      |                               |

| Index No     | chemical name  | Notes related to substances | EC No     | CAS No      | Classification                         | Labelling                                | Concentration Limits | Notes related to preparations |
|--------------|--|-----------------------------|-----------|-------------|--|--|----------------------|-------------------------------|
| 613-190-00-0 | disodium 1-amino-4-(2-(5-chloro-6-fluoro-pyrimidin-4-ylamino-methyl)-4-methyl-6-sulfo-phenylamino)-9,10-dioxo-9,10-dihydro-anthracene-2-sulfonate  |                             | 414-040-5 | 149530-93-8 | Xn; R22<br>R 43                        | Xn<br>R: 22-43<br>S: (2-)22-24-37        |                      |                               |
| 613-191-00-6 | 3-ethyl-2-methyl-2-(3-methylbutyl)-1,3-oxazolidine   |                             | 421-150-7 | 143860-04-2 | Repr.Cat.2; R60<br>C; R34<br>N; R50-53 | T; N<br>R: 60-34-50/53<br>S: 53-45-60-61 |                      |                               |
| 613-193-00-7 | pentakis[3-(dimethylammonio)propylsulfamoyl]-[(6-hydroxy-4,4,8,8-tetramethyl-4,8-diazoniaundecane-1,11-diyl-disulfamoyl)di[phthalocyaninecopper(II)]] heptalactate   |                             | 414-930-3 | —           | N; R51-53                              | N<br>R: 51/53<br>S: 61                   |                      |                               |
| 613-194-00-2 | 6,13-dichloro-3,10-bis{2-[4-fluoro-6-(2-sulfo-phenylamino)-1,3,5-triazin-2-ylamino]propylamino}benzo[5,6][1,4]oxazino[2,3-b.]phenoxazine-4,11-disulphonic acid, lithium-, sodium salt.   |                             | 418-000-8 | 163062-28-0 | Xi; R41                                | Xi<br>R: 41<br>S: (2-)22-26-39           |                      |                               |
| 613-195-00-8 | 2,2-(1,4-phenylene)bis((4H-3,1-benzoxazine-4-one)  |                             | 418-280-1 | 18600-59-4  | R 43<br>R 53                           | Xi<br>R: 43-53<br>S: (2-)24-37-61        |                      |                               |
| 613-196-00-3 | 5-[[4-chloro-6-[[2-[[4-fluoro-6-[[5-hydroxy-6-(4-methoxy-2-sulfo-phenyl)azo]-7-sulfo-2-naphthalenyl]amino]-1,3,5-triazin-2-yl]amino]-1-methylethyl]amino]-1,3,5-triazin-2-yl]amino]-3-[[4-(ethenylsulfonyl)phenyl]azo]-4-hydroxy-naphtalene-2,7-disulfonic acid, sodium salt |                             | 418-380-5 | 168113-78-8 | Xi; R41                                | Xi<br>R: 41<br>S: (2-)26-39              |                      |                               |

| Index No     | chemical name   | Notes related to substances | EC No     | CAS No      | Classification  | Labelling  | Concentration Limits | Notes related to preparations |
|--------------|---|-----------------------------|-----------|-------------|---|--|----------------------|-------------------------------|
| 613-197-00-9 | A mixture of: 2,4,6-tri(butylcarbamoyl)-1,3,5-triazine<br>2,4,6-tri(methylcarbamoyl)-1,3,5-triazine<br>[(2-butyl-4,6-dimethyl)tricarbamoyl]-1,3,5-triazine<br>[(2,4-dibutyl-6-methyl)tricarbamoyl]-1,3,5-triazine   |                             | 420-390-1 | 187547-46-2 | R 43<br>N; R51-53   | Xi; N<br>R: 43-51/53<br>S: (2-)24-37-61                              |                      |                               |
| 613-199-00-X | A mixture of: 1,3,5-tris(3-aminomethylphenyl)-1,3,5-(1H,3H,5H)-triazine-2,4,6-trione<br>a mixture of oligomers of 3,5-bis(3-aminomethylphenyl)-1-poly[3,5-bis(3-aminomethylphenyl)-2,4,6-trioxo-1,3,5-(1H,3H,5H)-triazin-1-yl]-1,3,5-(1H,3H,5H)-triazine-2,4,6-trione |                             | 421-550-1 | —           | Carc.Cat.2; R45<br>Repr.Cat.2; R61<br>R 43<br>R 52-53                         | T<br>R: 45-61-43-52/53<br>S: 53-45-61                                |                      |                               |
| 613-200-00-3 | Reaction product of: copper, (29H,31H-phthalocyaninato(2-)-N29,N30,N31,N32)-, chlorosulfuric acid and 3-(2-sulfoxyethylsulfonyl)aniline, sodium salts   |                             | 420-980-7 | —           | Xi; R41   | Xi<br>R: 41<br>S: (2-)22-26-39                                       |                      |                               |
| 613-201-00-9 | (R)-5-bromo-3-(1-methyl-2-pyrrolidinyl methyl)-1H-indole  |                             | 422-390-5 | 143322-57-0 | Repr.Cat.3; R62<br>T; R39-48/25<br>Xn; R20/22<br>Xi; R41<br>R 43<br>N; R50-53 | T; N<br>R: 20/22-39-41-43-48/<br>25-62-50/53<br>S: (1/2-)53-45-60-61 |                      |                               |
| 613-202-00-4 | pymetrozine (ISO)<br>(E)-4,5-dihydro-6-methyl-4-(3-pyridylmethyleneamino)-1,2,4-triazin-3(2H)-one   |                             | —         | 123312-89-0 | Carc.Cat3; R40<br>R52-53  | Xn<br>R: 40-52/53<br>S: (2-)36/37-61                                 |                      |                               |



| Index No     | chemical name  | Notes related to substances | EC No                  | CAS No                                   | Classification                            | Labelling  | Concentration Limits   | Notes related to preparations |
|--------------|--|-----------------------------|------------------------|--|---|--|--|-------------------------------|
| 613-203-00-X | pyraflufen-ethyl<br>[1]<br>pyraflufen<br>[2]   |                             | - [1]<br>- [2]         | 129630-19-9<br>[1]<br>129630-17-7<br>[2] | N; R50-53                                 | N<br>R: 50/53<br>S: 60-61                                    |  |                               |
| 613-204-00-5 | oxadiargyl (ISO)<br>3-[2,4-dichloro-5-(2-propynyl-<br>oxy)phenyl]-5-(1,1-dimethyl-<br>ethyl)-1,3,4-oxadiazol-2(3H)-<br>one<br>5-tert-butyl-3-[2,4-dichloro-5-<br>(prop-2-ynloxy)phenyl]-1,3,4-<br>oxadiazol-2(3H)-one          |                             | 254-637-6              | 39807-15-3                               | Repr.Cat3; R63<br>Xn; R48/22<br>N; R50-53 | Xn; N<br>R: 48/22-63-50/53<br>S: (2-)36/37-46-60-61          |  |                               |
| 613-205-00-0 | propiconazole<br>(+)-1-[2-(2,4-dichlorophenyl)-4-<br>propyl-1,3-dioxolan-2-ylmethyl]-<br>1H-1,2,4-triazole   |                             | 262-104-4              | 60207-90-1                               | Xn; R22<br>R43<br>N; R50-53               | Xn; N<br>R: 22-43-50/53<br>S: (2-)36/37-46-60-61             |  |                               |
| 613-206-00-6 | fenamidone (ISO)<br>(S)-5-methyl-2-methylthio-5-<br>phenyl-3-phenylamino-3,5-dihy-<br>droimidazol-4-one  |                             | —                      | 161326-34-7                              | N; R50-53                                 | N<br>R: 50/53<br>S: 60-61                                    |  |                               |
| 613-207-00-1 | imazalil sulphate, aqueous<br>solution<br>1-[2-(allyloxy)ethyl-2-(2,4-<br>dichlorophenyl)]-1H-imidazo-<br>lium hydrogen sulphate<br>(±)-1-[2-(allyloxy)ethyl-2-(2,4-<br>dichlorophenyl)]-1H-imidazo-<br>lium hydrogen sulphate |                             | 261-351-5<br>281-291-3 | 58594-72-2<br>83918-57-4                 | Xn; R22<br>C; R34<br>R43<br>N; R50-53     | C; N<br>R: 22-34-43-50/53<br>S: (2-)26-36/37/39-45-<br>60-61 | C 50 %: C, Xn, N; R22-34-43-50-53<br>30 % < C ≤ 50 %: Xn, N; R22-38-41-43-<br>50-53<br>25 % ≤ C ≤ 30 %: Xn, N; R22-41-43-50-<br>53<br>15 % < C < 25 %: Xi, N; R41-43-51-53<br>5 % ≤ C ≤ 15 %: Xi, N; R36-43-51-53<br>2,5 % ≤ C < 5 %: Xi, N; R43-51-53<br>1 % ≤ C < 2,5 %: Xi; R43-52-53<br>0,25 % ≤ C < 1 %: R52-53 |                               |
| 613-208-00-7 | imazamox   |                             | —                      | 114311-32-9                              | N; R50-53                                 | N<br>R: 50/53<br>S: 60-61                                    |  |                               |

| Index No     | chemical name  | Notes related to substances | EC No     | CAS No      | Classification                                     | Labelling   | Concentration Limits | Notes related to preparations |
|--------------|--|-----------------------------|-----------|-------------|--|---|----------------------|-------------------------------|
| 613-209-00-2 | cis-1-(3-chloropropyl)-2,6-dimethyl-piperidin hydrochloride  |                             | 417-430-3 | 63645-17-0  | T; R25<br>Xn; R48/22<br>R43<br>N; R51-53           | T; N<br>R: 25-43-48/22-51/53<br>S: (1/2-)22-36/37-45-61             |                      |                               |
| 613-210-00-8 | 2-(3-chloropropyl)-2,5,5-trimethyl-1,3-dioxane   |                             | 417-650-1 | 88128-57-8  | Xn; R48/22<br>R52-53                               | Xn<br>R: 48/22-52/53<br>S: (2-)23-25-36-61                          |                      |                               |
| 613-211-00-3 | N-methyl-4-(p-formylstyryl)pyridinium methylsulfate  |                             | 418-240-3 | 74401-04-0  | R43<br>R52-53                                      | Xi<br>R: 43-52/53<br>S: (2-)22-24-37-61                             |                      |                               |
| 613-212-00-9 | 4-[4-(2-ethylhexyloxy)phenyl](1,4-thiazinane-1,1-dioxide)  |                             | 418-320-8 | 133467-41-1 | Xn; R22<br>N; R50-53                               | Xn; N<br>R: 22-50/53<br>S: (2-)22-60-61                             |                      |                               |
| 613-213-00-4 | cis-1-benzoyl-4-[(4-methylsulfonyloxy]-L-proline   |                             | 416-040-0 | 120807-02-5 | R 52-53  | R: 52/53<br>S: 61   |                      |                               |
| 613-214-00-X | N,N-di-n-butyl-2-(1,2-dihydro-3-hydroxy-6-isopropyl-2-quinolyldene)-1,3-dioxindan-5-carboxamide  |                             | 416-260-7 | 147613-95-4 | R 53   | R: 53<br>S: 61  |                      |                               |
| 613-215-00-5 | 2-chloromethyl-3,4-dimethoxy-pyridinium chloride   |                             | 416-440-5 | 72830-09-2  | Xn; R21/22-48/22<br>Xi; R38-41<br>R43<br>N; R51-53 | Xn; N<br>R: 21/22-38-41-43-48/<br>22-51/53<br>S: (2-)26-36/37/39-61 |                      |                               |
| 613-216-00-0 | 6-tert-butyl-7-(6-diethylamino-2-methyl-3-pyridylimino)-3-(3-methylphenyl)pyrazolo[3,2-c][1,2,4]triazole   |                             | 416-490-8 | —           | N; R50-53  | N<br>R: 50/53<br>S: 60-61   |                      |                               |
| 613-217-00-6 | 4-[3-(3,5-di-tert-butyl-4-hydroxyphenyl)propionyloxy]-1-[2-[3-(3,5-di-tert-butyl-4-hydroxyphenyl)propionyloxy]ethyl]-2,2,6,6-tetramethylpiperidine |                             | 416-770-1 | 73754-27-5  | R 53   | R: 53<br>S: 61  |                      |                               |

| Index No     | chemical name   | Notes related to substances | EC No     | CAS No      | Classification                         | Labelling  | Concentration Limits | Notes related to preparations |
|--------------|---|-----------------------------|-----------|-------------|--|--|----------------------|-------------------------------|
| 613-218-00-1 | 6-hydroxyindole   |                             | 417-020-4 | 2380-86-1   | Xn; R22<br>Xi; R41<br>R43<br>N; R51-53 | Xn; N<br>R: 22-41-43-51/53<br>S: (2-)24-26-37/39-61        |                      |                               |
| 613-219-00-7 | 7a-ethyl-3,5-bis(1-methylethyl)-2,3,4,5-tetrahydrooxazolo[3,4-c]-2,3,4,5-tetrahydrooxazole  |                             | 417-140-7 | 79185-77-6  | Xi; R38<br>N; R51-53                   | Xi; N<br>R: 38-51/53<br>S: (2-)37-61                       |                      |                               |
| 613-220-00-2 | trans-(4S,6S)-5,6-dihydro-6-methyl-4H-thieno[2,3-b]thiopyran-4-ol, 7,7-dioxide  |                             | 417-290-3 | 147086-81-5 | Xn; R22                                | Xn<br>R: 22<br>S: (2-)36                                   |                      |                               |
| 613-221-00-8 | 2-chloro-5-methyl-pyridine  |                             | 418-050-0 | 18368-64-4  | Xn; R21/22<br>Xi; R38<br>R52-53        | Xn<br>R: 21/22-38-52/53<br>S: (2-)23-25-36/37-61           |                      |                               |
| 613-222-00-3 | 4-(1-oxo-2-propenyl)-morpholine   |                             | 418-140-1 | 5117-12-4   | Xn; R22-48/22<br>Xi; R41<br>R43        | Xn<br>R: 22-41-43-48/22<br>S: (2-)23-26-36/37/39           |                      |                               |
| 613-223-00-9 | N-isopropyl-3-(4-fluorophenyl)-1H-indole  |                             | 418-790-4 | 93957-49-4  | R 53                                   | R: 53<br>S: 61   |                      |                               |
| 613-224-00-4 | 2,5-dimercaptomethyl-1,4-dithiane   |                             | 419-770-8 | 136122-15-1 | Xn; R22<br>C; R34<br>R43<br>N; R50-53  | C; N<br>R: 22-34-43-50/53<br>S: (1/2-)26-36/37/39-45-60-61 |                      |                               |
| 613-225-00-X | A mixture of:[2-(anthraquinon-1-ylamino)-6-[(5-benzoylamino)anthraquinone-1-ylamino]-4-phenyl]-1,3,5-triazine 2,6-bis-[(5-benzoylamino)anthraquinon-1-ylamino]-4-phenyl-1,3,5-triazine. |                             | 421-290-9 | —           | Xn; R48/22<br>R53                      | Xn<br>R: 48/22-53<br>S: (2-)22-36-61                       |                      |                               |

| Index No     | chemical name  | Notes related to substances | EC No     | CAS No      | Classification       | Labelling                                     | Concentration Limits | Notes related to preparations |
|--------------|--|-----------------------------|-----------|-------------|----------------------|---|----------------------|-------------------------------|
| 613-226-00-5 | 1-(2-(ethyl(4-(4-(4-(ethyl(2-pyridinoethyl)amino)-2-methylphenylazo)benzoylamino)-phenylazo)-3-methylphenylamino)ethyl-pyridinium dichloride   |                             | 420-950-3 | 163831-67-2 | Xi; R41<br>N; R50-53 | Xi; N<br>R: 41-50/53<br>S: (2-)26-39-60-61    |                      |                               |
| 613-227-00-0 | (+/-)-[(R*,R*)and(R*,S*)]-6-fluoro-3,4-dihydro-2-oxiranyl-2H-1-benzopyran  |                             | 419-600-2 | —           | R 43<br>N; R51-53    | Xi; N<br>R: 43-51/53<br>S: (2-)24-28-36/37-61 |                      |                               |
| 613-228-00-6 | (+/-)-(R*,S*)-6-fluoro-3,4-dihydro-2-oxiranyl-2H-1-benzopyran  |                             | 419-630-6 | —           | N; R51-53            | N<br>R: 51/53<br>S: 24-61                     |                      |                               |
| 613-230-00-7 | florasulam (ISO)<br>2',6',8-trifluoro-5-methoxy-5-triazolo[1,5-c]<br>pyrimidine-2-sulfonanilide  |                             | —         | 145701-23-1 | N; R50-53            | N<br>R: 50/53<br>S: 60-61                     |                      |                               |
| 613-233-00-3 | 4,4'-(oxy-(bismethylene))-bis-1,3-dioxolane  |                             | 423-230-7 | 56552-15-9  | Xi; R41              | Xi<br>R: 41<br>S: (2-)26-39                   |                      |                               |
| 614-028-00-1 | A mixture of: 2-ethylhexyl mono-D-glucopyranoside<br>2-ethylhexyl di-D-glucopyranoside   |                             | 414-420-0 | —           | Xi; R41              | Xi<br>R: 41<br>S: (2-)26-39                   |                      |                               |
| 614-029-00-7 | Constitutional isomers of penta-O-allyl-β-D-fructofuranosyl-α-D-glucopyranoside<br>Constitutional isomers of hexa-O-allyl-β-D-fructofuranosyl-α-D-glucopyranoside<br>Constitutional isomers of hepta-O-allyl-β-D-fructofuranosyl-α-D-glucopyranoside |                             | 419-640-0 | 68784-14-5  | Xn; R22              | Xn<br>R: 22<br>S: (2-)                        |                      |                               |

| Index No     | chemical name   | Notes related to substances | EC No     | CAS No      | Classification                    | Labelling  | Concentration Limits | Notes related to preparations |
|--------------|---|-----------------------------|-----------|-------------|-----------------------------------|--|----------------------|-------------------------------|
| 615-030-00-5 | alkali salts, alkali earth salts and other salts of thiocyanic acid not mentioned elsewhere in this Annex                     | A                           | —         | —           | Xn; R20/21/22<br>R32<br>R52-53    | Xn<br>R: 20/21/22-32-52/53<br>S: (2-)13-61       |                      |                               |
| 615-031-00-0 | thallium salt of thiocyanic acid  | A                           | 222-571-7 | 3535-84-0   | Xn; R20/21/22<br>R32<br>N; R51-53 | Xn; N<br>R: 20/21/22-32-51/53<br>S: (2-)13-61    |                      |                               |
| 615-032-00-6 | metal salts of thiocyanic acid not mentioned elsewhere in this Annex  | A                           | —         | —           | Xn; R20/21/22<br>R32<br>N; R50-53 | Xn; N<br>R: 20/21/22-32-50/53<br>S: (2-)13-60-61 |                      |                               |
| 616-092-00-6 | Polymeric reaction product of bicyclo[2.2.1]hepta-2,5-diene, ethene, 1,4-hexadiene, 1-propene with N,N-di-2-propenylformamide |                             | 404-035-6 | —           | R 43<br>R 53                      | Xi<br>R: 43-53<br>S: (2-)24-37-61                |                      |                               |
| 616-093-00-1 | Reaction products of: aniline-terephthalaldehyde-o-toluidine condensate with maleic anhydride                                 |                             | 406-620-1 | 129217-90-9 | R 43<br>N; R51-53                 | Xi; N<br>R: 43-51/53<br>S: (2-)24-37-61          |                      |                               |
| 616-094-00-7 | 3,3'-dicyclohexyl-1,1'-methylenebis(4,1-phenylene)diurea  |                             | 406-370-3 | 58890-25-8  | R 43<br>R 53                      | Xi<br>R: 43-53<br>S: (2-)24-37-61                |                      |                               |
| 616-095-00-2 | 3,3'-dioctadecyl-1,1'-methylenebis(4,1-phenylene)diurea   |                             | 406-690-3 | 43136-14-7  | R 53                              | R: 53<br>S: 61                                   |                      |                               |
| 616-096-00-8 | N-(3-hexadecyloxy-2-hydroxyprop-1-yl)-N-(2-hydroxyethyl)-palmitamide  |                             | 408-110-4 | 110483-07-3 | R 53                              | R: 53<br>S: 61                                   |                      |                               |

| Index No     | chemical name  | Notes related to substances | EC No     | CAS No      | Classification     | Labelling                               | Concentration Limits | Notes related to preparations |
|--------------|--|-----------------------------|-----------|-------------|--------------------|---|----------------------|-------------------------------|
| 616-097-00-3 | N,N'-1,4-phenylenebis(2-((2-methoxy-4-nitrophenyl)azo)-3-oxobutanamide   |                             | 411-840-6 | 83372-55-8  | R 53               | R: 53<br>S: 61                          |                      |                               |
| 616-098-00-9 | 1-[4-chloro-3-((2,2,3,3,3-pentafluoropropoxy)methyl)phenyl]-5-phenyl-1H-1,2,4-triazole-3-carboxamide   |                             | 411-750-7 | 119126-15-7 | N; R51-53          | N<br>R: 51/53<br>S: 61                  |                      |                               |
| 616-099-00-4 | 2-[4-[(4-hydroxyphenyl)sulfonyl]phenoxy]-4,4-dimethyl-N-[5-[(methylsulfonyl)amino]-2-[4-(1,1,3,3-tetramethylbutyl)phenoxy]phenyl]-3-oxopentanamide   |                             | 414-170-2 | 135937-20-1 | R 53               | R: 53<br>S: 61                          |                      |                               |
| 616-100-00-8 | 1,3-dimethyl-1,3-bis(trimethylsilyl)urea   |                             | 414-180-7 | 10218-17-4  | Xn; R22<br>Xi; R38 | Xn<br>R: 22-38<br>S: (2-)36/37          |                      |                               |
| 616-101-00-3 | (S)-N-tert-butyl-1,2,3,4-tetrahydro-3-isoquinolinecarboxamide  |                             | 414-600-9 | 149182-72-9 | Xn; R22<br>R 52-53 | Xn<br>R: 22-52/53<br>S: (2-)61          |                      |                               |
| 616-102-00-9 | A mixture of: α-[3-(3-mercaptopropanoxycarbonylamino)methylphenylaminocarbonyl]-ω-[3-(3-mercaptopropanoxycarbonylamino)methylphenylaminocarbonyloxy]-poly-(oxyethylene-co-oxypropylene) 1,2-(or 1,3-)bis[α-(3-mercaptopropanoxycarbonylamino)methylphenylaminocarbonyl]-ω-oxy-poly(oxyethylene-co-oxypropylene)]-3-(or 2-)propanol 1,2,3-tris[α-(3-mercaptopropanoxycarbonyl-amino)methylphenylaminocarbonyl]-ω-oxy-poly-(oxyethylene-co-oxypropylene)]-propane] |                             | 415-870-0 | —           | R 43<br>N; R51-53  | Xi; N<br>R: 43-51/53<br>S: (2-)36/37-61 |                      |                               |

| Index No     | chemical name  | Notes related to substances | EC No     | CAS No      | Classification                                      | Labelling   | Concentration Limits | Notes related to preparations |
|--------------|--|-----------------------------|-----------|-------------|---|---|----------------------|-------------------------------|
| 616-103-00-4 | (S,S)-trans-4-(acetylamino)-5,6-dihydro-6-methyl-7,7-dioxo-4H-thieno[2,3-b]thiopyran-2-sulfonamide         |                             | 415-030-3 | 120298-38-6 | R43<br>N; R50-53                                    | Xi; N<br>R: 43-50/53<br>S: (2-)24-37-60-61          |                      |                               |
| 616-104-00-X | benalaxyl<br>methyl N-(2,6-dimethylphenyl)-N-(phenylacetyl)-DL-alaninate                                   |                             | 275-728-7 | 71626-11-4  | N; R50-53   | N<br>R: 50/53<br>S: 60-61                           |                      |                               |
| 616-105-00-5 | chlorotoluron<br>3-(3-chloro-p-tolyl)-1,1-dimethylurea   |                             | 239-592-2 | 15545-48-9  | Carc. Cat. 3; R40<br>Repr. Cat. 3; R63<br>N; R50-53 | Xn; N<br>R: 40-63-50/53<br>S: (2-)36/37-26-46-60-61 |                      |                               |
| 616-106-00-0 | phenmedipham<br>methyl 3-(3-methylcarbaniloyloxy)carbanilate (ISO)   |                             | 237-199-0 | 13684-63-4  | N; R50-53   | N<br>R: 50/53<br>S: 60-61                           |                      |                               |
| 616-108-00-1 | iodosulfuron-methyl-sodium   |                             | —         | 144550-36-7 | N; R50-53   | N<br>R: 50/53<br>S: 60-61                           |                      |                               |
| 616-109-00-7 | sulfosulfuron<br>1-(4,6-dimethoxypyrimidin-2-yl)-3-(2-ethylsulfonylimidazo[1,2-a]pyridin-3-yl)sulfonylurea |                             | —         | 141776-32-1 | N; R50-53   | N<br>R: 50/53<br>S: 60-61                           |                      |                               |
| 616-110-00-2 | cyclanilide<br>1-(2,4-dichloroanilincarboxyl)-cyclopropanecarboxylic acid                                  |                             | 419-150-7 | 113136-77-9 | Xn; R22<br>N; R51-53                                | Xn; N<br>R: 22-51/53<br>S: (2-)61                   |                      |                               |
| 616-111-00-8 | fenhexamid<br>N-(2,3-dichlor-4-hydroxyphenyl)-1-methylcyclohexancarboxamid                                 |                             | 422-530-5 | 126833-17-8 | N; R51-53   | N<br>R: 51/53<br>S: 61                              |                      |                               |

| Index No     | chemical name  | Notes related to substances | EC No     | CAS No      | Classification                      | Labelling  | Concentration Limits  | Notes related to preparations |
|--------------|--|-----------------------------|-----------|-------------|-------------------------------------|--|---|-------------------------------|
| 616-112-00-3 | oxasulfuron<br>oxetan-3-yl 2-[(4,6-dimethylpyrimidin-2-yl)-carbamoylsulfamoyl]benzoate   |                             | —         | 144651-06-9 | Xn; R48/22<br>N; R50-53             | Xn; N<br>R: 48/22-50/53<br>S: (2-)46-60-61       |   |                               |
| 616-113-00-9 | desmedipham<br>ethyl 3-phenylcarbamoyloxyphenylcarbamate   |                             | 237-198-5 | 13684-56-5  | N; R50-53                           | N<br>R: 50/53<br>S: 60-61                        | C ≥ 2,5 %: N; R50/53<br>0,25 % ≤ C < 2,5 %: N; R51/53<br>0,025 % ≤ C < 0,25 %: R52/53 |                               |
| 616-114-00-4 | dodecanamide, N,N'-(9,9',10,10'-tetrahydro-9,9',10,10'-tetraoxo(1,1'-bianthracene)-4,4'-diyl)bis-  |                             | 418-010-2 | 136897-58-0 | R53                                 | R: 53<br>S: 22-61                                |   |                               |
| 616-115-00-X | N-(3-acetyl-2-hydroxyphenyl)-4-(4-phenylbutoxy)benzamide   |                             | 416-150-9 | 136450-06-1 | R 53                                | R: 53<br>S: 61                                   |   |                               |
| 616-116-00-5 | N-(4-dimethylaminopyridinium)-3-methoxy-4-(1-methyl-5-nitroindol-3-ylmethyl)-N-(o-tolylsulfonyl)benzamidate  |                             | 416-790-9 | —           | R 53                                | R: 53<br>S: 61                                   |   |                               |
| 616-117-00-0 | N-[2-(3-acetyl-5-nitrothiophen-2-ylazo)-5-diethylaminophenyl]acetamide   |                             | 416-860-9 | —           | Repr.Cat.3; R62<br>R43<br>N; R50-53 | Xn; N<br>R: 43-62-50/53<br>S: (2-)22-36/37-60-61 |   |                               |
| 616-118-00-6 | N-(2',6'-dimethylphenyl)-2-piperidinecarboxamide hydrochloride   |                             | 417-950-0 | 65797-42-4  | Xn; R22<br>R52-53                   | Xn<br>R: 22-52/53<br>S: (2-)22-61                |   |                               |
| 616-119-00-1 | 2-(1-butyl-3,5-dioxo-2-phenyl-(1,2,4)-triazolidin-4-yl)-4,4-dimethyl-3-oxo-N-(2-methoxy-5-(2-(dodecyl-1-sulfonyl))propionylamino)-phenyl)-pentanamide      |                             | 418-060-5 | 118020-93-2 | R 53                                | R: 53<br>S: 61                                   |   |                               |
| 616-120-00-7 | A mixture of: N-(3-dimethylamino-4-methylphenyl)-benzamide<br>N-(3-dimethylamino-2-methylphenyl)-benzamide<br>N-(3-dimethylamino-3-methylphenyl)-benzamide |                             | 420-600-1 | —           | Xn; R48/22<br>N; R51-53             | Xn; N<br>R: 48/22-51/53<br>S: (2-)36/37-61       |   |                               |
| 616-121-00-2 | 2,4-dihydroxy-N-(2-methoxyphenyl)benzamide   |                             | 419-090-1 | 129205-19-2 | R 43<br>N; R51-53                   | Xi; N<br>R: 43-51/53<br>S: (2-)24-37-61          |   |                               |



| Index No     | chemical name   | Notes related to substances | EC No     | CAS No      | Classification                 | Labelling   | Concentration Limits | Notes related to preparations |
|--------------|---|-----------------------------|-----------|-------------|--------------------------------|---|----------------------|-------------------------------|
| 616-123-00-3 | N-[3-[[4-(diethylamino)-2-methylphenyl]imino]-6-oxo-1,4-cyclohexadienyl]acetamide   |                             | 414-740-0 | 96141-86-5  | N; R50-53                      | N<br>R: 50/53<br>S: 60-61                               |                      |                               |
| 616-124-00-9 | lithium bis(trifluoromethylsulfonyl)imide   |                             | 415-300-0 | 90076-65-6  | T; R24/25<br>C; R34<br>R 52-53 | T<br>R: 24/25-34-52/53<br>S: (1/2-)22-26-36/37/39-45-61 |                      |                               |
| 616-125-00-4 | 3-cyano-N-(1,1-dimethylethyl)androsta-3,5-diene-17- $\beta$ -carboxamide  |                             | 415-730-9 | 151338-11-3 | N; R50-53                      | N<br>R: 50/53<br>S: 60-61                               |                      |                               |
| 616-127-00-5 | A mixture of: N,N'-Ethane-1,2-diylbis(decaneamide)<br>12-Hydroxy-N-[2-[1-oxydecyl]amino]ethyl]octadecaneamide<br>N,N'-Ethane-1,2-diylbis(12-hydroxyoctadecaneamide) |                             | 430-050-2 | —           | R43<br>N; R51-53               | Xi; N<br>R: 43-51/53<br>S: (2-)24-37-61                 |                      |                               |
| 616-128-00-0 | N-(2-(1-allyl-4,5-dicyanoimidazol-2-ylazo)-5-(dipropylamino)phenyl)-acetamide   |                             | 417-530-7 | 123590-00-1 | R53                            | R: 53<br>S: 61  |                      |                               |
| 616-129-00-6 | N,N'-bis(2,2,6,6-tetramethyl-4-piperidyl)isophthalamide   |                             | 419-710-0 | 42774-15-2  | Xn; R22<br>Xi; R36             | Xn<br>R: 22-36<br>S: (2-)22-25-26                       |                      |                               |
| 616-130-00-1 | N-(3-(2-(4,4-dimethyl-2,5-dioxoimidazolin-1-yl)-4,4-dimethyl-3-oxo-pentanoylamino)-4-methoxy-phenyl)-octadecaneamide  |                             | 421-780-2 | 150919-56-5 | R53                            | R: 53<br>S: 61  |                      |                               |
| 616-132-00-2 | N-[4-(4-cyano-2-furfurylidene-2,5-dihydro-5-oxo-3-furyl)phenyl]butane-1-sulfonamide   |                             | 423-250-6 | 130016-98-7 | N; R50-53                      | N<br>R: 50/53<br>S: 60-61                               |                      |                               |

| Index No     | chemical name  | Notes related to substances | EC No     | CAS No      | Classification                                | Labelling  | Concentration Limits | Notes related to preparations |
|--------------|--|-----------------------------|-----------|-------------|---|--|----------------------|-------------------------------|
| 616-133-00-8 | N-cyclohexyl-S,S-dioxobenzo[b]-thiophene-2-carboxamide   |                             | 423-990-1 | 149118-66-1 | Xn; R22<br>Xi; R41<br>N; R50-53               | Xn; N<br>R: 22-41-50/53<br>S: (2-)22-26-39-60-61       |                      |                               |
| 616-134-00-3 | 3,3'-bis(dioctyloxyphosphinothiolythio)-N,N'-oxybis(methylene)dipropionamide   |                             | 401-820-5 | —           | R52-53  | R: 52/53<br>S: 61                                      |                      |                               |
| 616-135-00-9 | (3S,4aS,8aS)-2-[(2R,3S)-3-amino-2-hydroxy-4-phenylbutyl]-N-tert-butyldecahydroisoquinoline-3-carboxamide   |                             | 430-230-0 | 136522-17-3 | Xn; R22<br>R52-53                             | Xn<br>R: 22-52/53<br>S: (2-)22-61                      |                      |                               |
| 616-142-00-7 | 1,3-Bis(vinylsulfonylacetamido)propane   |                             | 428-350-3 | 93629-90-4  | Muta.Cat.3; R68<br>Xi; R41<br>R 43<br>R 52-53 | Xn<br>R: 41-43-68-52/53<br>S: (2-)22-26-36/37/39-61    |                      |                               |
| 616-143-00-2 | N,N'-dihexadecyl-N,N'-bis(2-hydroxyethyl)propanediamide  |                             | 422-560-9 | 149591-38-8 | Xn; Repr. Cat. 3; R62<br>Xi; R36<br>R53       | Xn<br>R: 62-36-53<br>S: (2-)26-36/37-61                |                      |                               |
| 617-018-00-5 | A mixture of: 1-methyl-1-(3-(1-methylethyl)phenyl)ethyl-1-methyl-1-phenylethylperoxide, 63 % by weight<br>1-methyl-1-(4-(1-methylethyl)phenyl)ethyl-1-methyl-1-phenylethylperoxide, 31 % by weight |                             | 410-840-3 | 71566-50-2  | O; R7<br>N; R51-53                            | O; N<br>R: 7-51/53<br>S: (2-)3/7-14-36/37/39-61        |                      |                               |
| 617-019-00-0 | 6-(phthalimido)peroxyhexanoic acid   |                             | 410-850-8 | 128275-31-0 | O; R7<br>Xi; R41<br>N; R50                    | O; Xi; N<br>R: 7-41-50<br>S: (2-)3/7-14-26-36/37/39-61 |                      |                               |

| Index No     | chemical name  | Notes related to substances | EC No     | CAS No      | Classification                                      | Labelling  | Concentration Limits | Notes related to preparations |
|--------------|--|-----------------------------|-----------|-------------|---|--|----------------------|-------------------------------|
| 617-020-00-6 | 1,3-di(prop-2,2-diyl)benzene bis(neodecanoylperoxide)  |                             | 420-060-5 | 117663-11-3 | R10<br>O; R7<br>N; R51-53                           | O; N<br>R: 7-10-51/53<br>S: (2-)7-14-36/37/39-47-61              |                      |                               |
| 650-042-00-4 | Reaction product of: polyethylene-polyamine-(C16-C18)-alkylamides with monothio-(C2)-alkyl phosphonates                      |                             | 417-450-2 | —           | Xi; R36/38<br>R43<br>R52-53                         | Xi<br>R: 36/38-43-52/53<br>S: (2-)24-26-37-61                    |                      |                               |
| 650-043-00-X | Reaction product of: 3,5-bis-tert-butylsalicylic acid and aluminiumsulfate   |                             | 420-310-3 | —           | Xn; R22<br>N; R50-53                                | Xn; N<br>R: 22-50/53<br>S: (2-)22-56-60-61                       |                      |                               |
| 650-044-00-5 | mixed linear and branched C14-15 alcohols ethoxylated, reaction product with epichlorohydrin                                 |                             | 420-480-9 | 158570-99-1 | Xi; R38<br>R43<br>N; R50-53                         | Xi; N<br>R: 38-43-50/53<br>S: (2-)24-37-60-61                    |                      |                               |
| 650-045-00-0 | Reaction product of: 1,2,3-propanetricarboxylic acid, 2-hydroxy, diethyl ester, 1-propanol and zirconium tetra-n-propanolate |                             | 417-110-3 | —           | F; R11<br>Xi; R38-41<br>N; R51-53                   | F; Xi; N<br>R: 11-38-41-51/53<br>S: (2-)9-16-26-37/39-61         |                      |                               |
| 650-046-00-6 | di(tetramethylammonium)(29H,31H-phthalocyanin-N29,N30,N31,N32)disulfonamide disulfonate, cuprate(2-)complex, derivatives     |                             | 416-180-2 | —           | Xn; R22-48/22<br>N; R51-53                          | Xn; N<br>R: 22-48/22-51/53<br>S: (2-)22-36-61                    |                      |                               |
| 650-047-00-1 | dibenzylphenylsulfonium hexafluoroantimonate   |                             | 417-760-8 | 134164-24-2 | T; R48/25<br>Xn; R22<br>Xi; R41<br>R43<br>N; R51-53 | T; N<br>R: 22-41-43-48/25-51/53<br>S: (1/2-)22-26-36/37/39-45-61 |                      |                               |

| Index No     | chemical name   | Notes related to substances | EC No     | CAS No | Classification                             | Labelling   | Concentration Limits | Notes related to preparations |
|--------------|---|-----------------------------|-----------|--------|--|---|----------------------|-------------------------------|
| 650-048-00-7 | Reaction product of: borax, hydrogen peroxide, acetic acid anhydride and acetic acid  |                             | 420-070-1 | —      | O; R7<br>Xn; R20/21/22<br>C; R35<br>N; R50 | O; C; N<br>R: 7-20/21/22-35-50<br>S: (1/2-)3/7-14-26-36/<br>37/39-45-61 |                      |                               |
| 650-049-00-2 | 2-alkoxyloxyethyl hydrogen maleate, where alkoyl represents (by weight) 70 to 85 % unsaturated octadecoyl, 0.5 to 10 % saturated octadecoyl, and 2 to 18 % saturated hexadecoyl   |                             | 417-960-5 | —      | Xi; R38-41<br>R43<br>N; R50-53             | Xi; N<br>R: 38-41-43-50/53<br>S: (2-)24-26-37/39-60-61                  |                      |                               |
| 650-050-00-8 | A mixture of: 1-methyl-3-hydroxypropyl 3,5-[1,1-dimethylethyl]-4-hydroxydihydro-cinnamate and/or 3-hydroxybutyl 3,5-[1,1-dimethylethyl]-4-hydroxydihydrocinnamate<br>1,3-butanediol bis[3-(3'-(1,1-dimethylethyl)4'-hydroxyphenyl)propionate] isomers<br>1,3-butanediol bis[3-(3',5'-(1,1-dimethylethyl)-4'-hydroxyphenyl)propionate] isomers |                             | 423-600-8 | —      | N; R51-53                                  | N<br>R: 51/53<br>S: 61  |                      |                               |
| 650-055-00-5 | silver sodium zirconium hydrogenphosphate   |                             | 422-570-3 | —      | N; R50-53                                  | N<br>R: 50/53<br>S: 60-61'  |                      |                               |

## ANNEX 1D

| Index No     | chemical name  | Notes related to substances | EC No                          | CAS No                         | Classification   | Labelling  | Concentration Limits | Notes related to preparations |
|--------------|--|-----------------------------|--------------------------------|--------------------------------|--|--|----------------------|-------------------------------|
| 048-002-00-0 | cadmium (non-pyrophoric) [1]<br>cadmium oxide (non-pyrophoric) [2] | E                           | 231-152-8 [1]<br>215-146-2 [2] | 7440-43-9 [1]<br>1306-19-0 [2] | Carc. Cat. 2; R45<br>Muta. Cat. 3; R68<br>Repr. Cat. 3; R62-63<br>T; R48/23/25<br>T+; R26<br>N; R50-53           | T+; N<br>R: 45-26-48/23/25-62-63-68-50/53<br>S: 53-45-60-61              |                      |                               |
| 048-011-00-X | cadmium (pyrophoric)   | E                           | 231-152-8                      | 7440-43-9                      | Carc. Cat. 2; R45<br>Muta. Cat. 3; R68<br>Repr. Cat. 3; R62-63<br>T; R48/23/25<br>T+; R26<br>F; R17<br>N; R50-53 | F; T+; N<br>R: 45-17-26-48/23/25-62-63-68-50/53<br>S: 53-45-7/8-43-60-61 |                      |                               |
| 609-006-00-3 | 4-nitrotoluene   | C                           | 202-808-0                      | 99-99-0                        | T; R23/24/25<br>R33<br>N; R51/53   | T; N<br>R: 23/24/25-33-51/53<br>S: (1/2-)28-37-45-61                     |                      |                               |
| 609-065-00-5 | 2-nitrotoluene   | E                           | 201-853-3                      | 88-72-2                        | Carc. Cat. 2; R45<br>Muta. Cat. 2; R46<br>Repr. Cat. 3; R62<br>Xn; R22<br>N; R51-53                              | T; N<br>R: 45-46-22-62-51/53<br>S: 53-45-61                              |                      |                               |
| 612-039-00-6 | 2-ethoxyaniline<br>o-phenetidine                                   | C                           | 202-356-4                      | 94-70-2                        | T; R23/24/25<br>R33  | T<br>R: 23/24/25-33<br>S: (1/2-)28-36/37-45                              |                      |                               |
| 612-207-00-9 | 4-ethoxyaniline<br>p-phenetidine                                   |                             | 205-855-5                      | 156-43-4                       | Muta. Cat. 3; R68<br>Xn; R20/21/22<br>Xi; R36<br>R43   | Xn<br>R: 20/21/22-36-43-68<br>S: (2-)36/37-46'                           |                      |                               |

## ANNEX 2A

## A.21. OXIDIZING PROPERTIES (LIQUIDS)

## 1. METHOD

## 1.1 INTRODUCTION

This test method is designed to measure the potential for a liquid substance to increase the burning rate or burning intensity of a combustible substance, or to form a mixture with a combustible substance which spontaneously ignites, when the two are thoroughly mixed. It is based on the UN test for oxidizing liquids (1) and is equivalent to it. However, as this method A.21 is primarily designed to satisfy the requirements of Dir 67/548, comparison with only one reference substance is required. Testing and comparison to additional reference substances may be necessary when the results of the test are expected to be used for other purposes (1).

This test need not be performed when examination of the structural formula establishes beyond reasonable doubt that the substance is incapable of reacting exothermically with a combustible material.

It is useful to have preliminary information on any potential explosive properties of the substance before performing this test.

This test is not applicable to solids, gases, explosive or highly flammable substances, or organic peroxides.

This test may not need be performed when results for the test substance in the UN test for oxidizing liquids (1) are already available.

## 1.2 DEFINITIONS AND UNITS

**Mean pressure rise time** is the mean of the measured times for a mixture under test to produce a pressure rise from 690 kPa to 2 070 kPa above atmospheric.

## 1.3 REFERENCE SUBSTANCE

65 % (w/w) aqueous nitric acid (analytical grade) is required as a reference substance (2).

Optionally, if the experimenter foresees that the results of this test may eventually be used for other purposes,<sup>1</sup> testing of additional reference substances may also be appropriate (3).

## 1.4 PRINCIPLE OF THE TEST METHOD

The liquid to be tested is mixed in a 1 to 1 ratio, by mass, with fibrous cellulose and introduced into a pressure vessel. If during mixing or filling spontaneous ignition occurs, no further testing is necessary.

If spontaneous ignition does not occur the full test is carried out. The mixture is heated in a pressure vessel and the mean time taken for the pressure to rise from 690 kPa to 2 070 kPa above atmospheric is determined. This is compared with the mean pressure rise time for the 1:1 mixture of the reference substance(s) and cellulose.

(1) As, for example, in the framework of UN transport regulations.

(2) The acid should be titrated before testing to confirm its concentration.

(3) E.g.: 50 % (w/w) perchloric acid and 40 % (w/w) sodium chlorate are used in reference 1.

## 1.5 QUALITY CRITERIA

In a series of five trials on a single substance no results should differ by more than 30 % from the arithmetic mean. Results that differ by more than 30 % from the mean should be discarded, the mixing and filling procedure improved and the testing repeated.

## 1.6 DESCRIPTION OF THE METHOD

1.6.1 **Preparation**1.6.1.1 *Combustible substance*

Dried, fibrous cellulose with a fibre length between 50 and 250  $\mu\text{m}$  and a mean diameter of 25  $\mu\text{m}$  <sup>(4)</sup>, is used as the combustible material. It is dried to constant weight in a layer not more than 25 mm thick at 105 °C for 4 hours and kept in a desiccator, with desiccant, until cool and required for use. The water content of the dried cellulose should be less than 0.5 % by dry mass <sup>(5)</sup>. If necessary, the drying time should be prolonged to achieve this <sup>(6)</sup>. The same batch of cellulose is to be used throughout the test.

1.6.1.2 *Apparatus*1.6.1.2.1 *Pressure vessel*

A pressure vessel is required. The vessel consists of a cylindrical steel pressure vessel 89 mm in length and 60 mm in external diameter (see figure 1). Two flats are machined on opposite sides (reducing the cross-section of the vessel to 50 mm) to facilitate holding whilst fitting up the firing plug and vent plug. The vessel, which has a bore of 20 mm diameter is internally rebated at either end to a depth of 19 mm and threaded to accept 1" British Standard Pipe (BSP) or metric equivalent. A pressure take-off, in the form of a side arm, is screwed into the curved face of the pressure vessel 35 mm from one end and at 90° to the machined flats. The socket for this is bored to a depth of 12 mm and threaded to accept the 1/2" BSP (or metric equivalent) thread on the end of the side-arm. If necessary, an inert seal is fitted to ensure a gas-tight seal. The side-arm extends 55 mm beyond the pressure vessel body and has a bore of 6 mm. The end of the side-arm is rebated and threaded to accept a diaphragm type pressure transducer. Any pressure-measuring device may be used provided that it is not affected by the hot gases or the decomposition products and is capable of responding to rates of pressure rise of 690-2 070 kPa in not more than 5 ms.

The end of the pressure vessel farthest from the side-arm is closed with a firing plug which is fitted with two electrodes, one insulated from, and the other earthed to, the plug body. The other end of the pressure vessel is closed by a bursting disk (bursting pressure approximately 2 200 kPa) held in place with a retaining plug which has a 20 mm bore. If necessary, an inert seal is used with the firing plug to ensure a gas-tight fit. A support stand (figure 2) holds the assembly in the correct attitude during use. This usually comprises a mild steel base plate measuring 235 mm x 184 mm x 6 mm and a 185 mm length of square hollow section (S.H.S.) 70 mm x 70 mm x 4 mm.

A section is cut from each of two opposite sides at one end of the length of S.H.S. so that a structure having two flat sided legs surmounted by 86 mm length of intact box section results. The ends of these flat sides are cut to an angle of 60° to the horizontal and welded to the base plate. A slot measuring 22 mm wide x 46 mm deep is machined in one side of the upper end of the base section such that when the pressure vessel assembly is lowered, firing plug end first, into the box section support, the side-arm is accommodated in the slot. A piece of steel 30 mm wide and 6 mm thick is welded to the lower internal face of the box section to act as a spacer. Two 7 mm thumb screws, tapped into the opposite face, serve to hold the pressure vessel firmly in place. Two 12 mm wide strips of 6 mm thick steel, welded to the side pieces abutting the base of the box section, support the pressure vessel from beneath.

<sup>(4)</sup> e.g. Whatman Column Chromatographic Cellulose Powder CF 11, catalogue no 4021 050

<sup>(5)</sup> Confirmed by (e.g.) Karl-Fisher titration

<sup>(6)</sup> Alternatively, this water content can also be achieved by (e.g.) heating at 105 °C under vacuum for 24 h

1.6.1.2.2 *Ignition System*

The ignition system consists of a 25 cm long Ni/Cr wire with a diameter 0.6 mm and a resistance of 3.85 ohm/m. The wire is wound, using a 5 mm diameter rod, in the shape of a coil and is attached to the firing plug electrodes. The coil should have one of the configurations shown in figure 3. The distance between the bottom of the vessel and the underside of the ignition coil should be 20 mm. If the electrodes are not adjustable, the ends of the ignition wire between the coil and the bottom of the vessel should be insulated by a ceramic sheath. The wire is heated by a constant current power supply able to deliver at least 10 A.

1.6.2 **Performance of the test** <sup>(7)</sup>

The apparatus, assembled complete with pressure transducer and heating system but without the bursting disk in position, is supported firing plug end down. 2.5 g of the liquid to be tested is mixed with 2.5 g of dried cellulose in a glass beaker using a glass stirring rod <sup>(8)</sup>. For safety, the mixing should be performed with a safety shield between the operator and mixture. If the mixture ignites during mixing or filling, no further testing is necessary. The mixture is added, in small portions with tapping, to the pressure vessel making sure that the mixture is packed around the ignition coil and is in good contact with it. It is important that the coil is not distorted during the packing process as this may lead to erroneous results <sup>(9)</sup>. The bursting disk is placed in position and the retaining plug is screwed in tightly. The charged vessel is transferred to the firing support stand, bursting disk uppermost, which should be located in a suitable, armoured fume cupboard or firing cell. The power supply is connected to the external terminals of the firing plug and 10 A applied. The time between the start of mixing and switching on the power should not exceed 10 minutes.

The signal produced by the pressure transducer is recorded on a suitable system which allows both evaluation and the generation of a permanent record of the time pressure profile obtained (e.g. a transient recorder coupled to a chart recorder). The mixture is heated until the bursting disk ruptures or until at least 60 s have elapsed. If the bursting disk does not rupture, the mixture should be allowed to cool before carefully dismantling the apparatus, taking precautions to allow for any pressurization which may occur. Five trials are performed with the test substance and the reference substance(s). The time taken for the pressure to rise from 690 kPa to 2 070 kPa above atmospheric is noted. The mean pressure rise time is calculated.

In some cases, substances may generate a pressure rise (too high or too low), caused by chemical reactions not characterizing the oxidizing properties of the substance. In these cases, it may be necessary to repeat the test with an inert substance, e.g. diatomite (kieselguhr), in place of the cellulose in order to clarify the nature of the reaction.

2. **DATA**

Pressure rise times for both the test substance and the reference substance(s).

Pressure rise times for the tests with an inert substance, if performed.

## 2.1 TREATMENT OF RESULTS

The mean pressure rise times for both the test substance and the reference substances(s) are calculated.

The mean pressure rise time for the tests with an inert substance (if performed) is calculated.

<sup>(7)</sup> Mixtures of oxidizers with cellulose must be treated as potentially explosive and handled with due care

<sup>(8)</sup> In practice this can be achieved by preparing a 1:1 mixture of the liquid to be tested and cellulose in a greater amount than needed for the trial and transferring  $5 \pm 0.1$  g to the pressure vessel. The mixture is to be freshly prepared for each trial.

<sup>(9)</sup> In particular, contact between the adjacent turns of the coil must be avoided.



Some examples of results are shown in Table 1

Table 1

**Examples of results <sup>(d)</sup>**

| Substance <sup>(c)</sup>                          | Mean pressure rise time for a 1:1 mixture with cellulose (ms) |
|---|---|
| Ammonium dichromate, saturated aqueous solution   | 20 800  |
| Calcium nitrate, saturated aqueous solution       | 6 700   |
| Ferric nitrate, saturated aqueous solution        | 4 133   |
| Lithium perchlorate, saturated aqueous solution   | 1 686   |
| Magnesium perchlorate, saturated aqueous solution | 777   |
| Nickel nitrate, saturated aqueous solution        | 6 250   |
| Nitric acid, 65 %                                 | 4 767 <sup>(a)</sup>  |
| Perchloric acid, 50 %                             | 121 <sup>(a)</sup>  |
| Perchloric acid, 55 %                             | 59  |
| Potassium nitrate, 30 % aqueous solution          | 26 690  |
| Silver nitrate, saturated aqueous solution        | — <sup>(b)</sup>  |
| Sodium chlorate, 40 % aqueous solution            | 2 555 <sup>(a)</sup>  |
| Sodium nitrate, 45 % aqueous solution             | 4 133   |
| <i>Inert Substance</i>                            |   |
| Water:cellulose                                   | — <sup>(b)</sup>  |

<sup>(a)</sup> Mean value from interlaboratory comparative trials  
<sup>(b)</sup> Maximum pressure of 2 070 kPa not reached  
<sup>(c)</sup> Saturated solutions should be prepared at 20 °C  
<sup>(d)</sup> See reference (1) for classification under the UN transport scheme

### 3. REPORT

#### 3.1 TEST REPORT

The test report should include the following information:

- the identity, composition, purity, etc of the substance tested;
- the concentration of the test substance;
- the drying procedure of the cellulose used
- the water content of the cellulose used
- the results of the measurements;
- the results from tests with an inert substance, if any;
- the calculated mean pressure rise times;
- any deviations from this method and the reasons for them;
- all additional information or remarks relevant to the interpretation of the results;

3.2 INTERPRETATION OF THE RESULTS <sup>(10)</sup>

The test results are assessed on the basis of:

- a) whether the mixture of test substance and cellulose spontaneously ignites; and
- b) the comparison of the mean time taken for the pressure to rise from 690 kPa to 2 070 kPa with that of the reference substance(s).

A liquid substance is to be considered as an oxidizer when:

- a) a 1:1 mixture, by mass, of the substance and cellulose spontaneously ignites; or
- b) a 1:1 mixture, by mass, of the substance and cellulose exhibits a mean pressure rise time less than or equal to the mean pressure rise time of a 1:1 mixture, by mass, of 65 % (w/w) aqueous nitric acid and cellulose.

In order to avoid a false positive result, if necessary, the results obtained when testing the substance with an inert material should also be considered when interpreting the results.

## 4. REFERENCES

- (1) Recommendations on the Transport of Dangerous Goods, Manual of Tests and Criteria. 3rd revised edition. UN Publication No: ST/SG/AC.10/11/Rev. 3, 1999, page 342. Test O.2: Test for oxidizing liquids.

---

<sup>(10)</sup> See reference 1 for interpretation of the results under the UN transport regulations using several reference substances.

Figure 1

## Pressure vessel

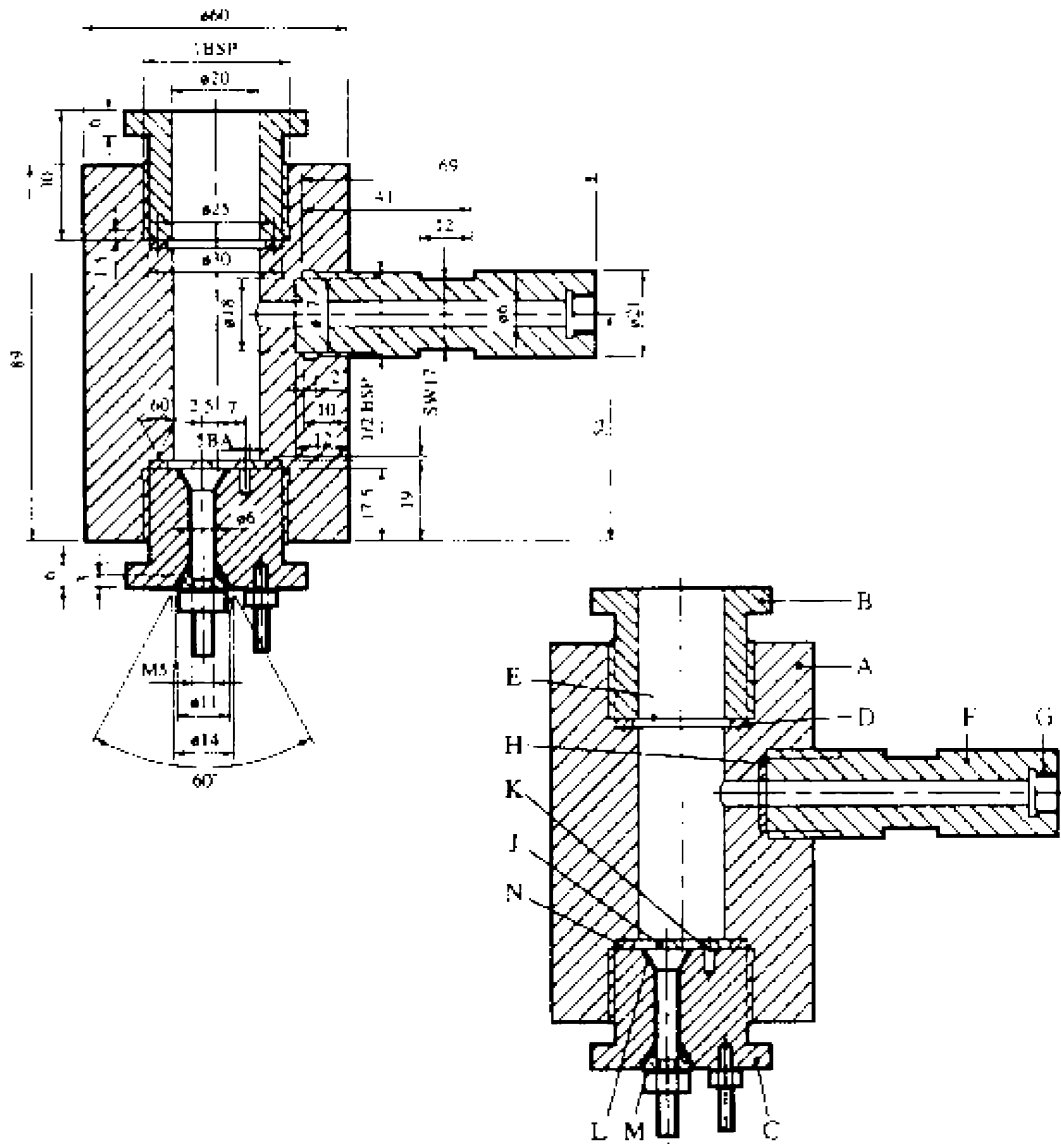

- |                              |                                  |                         |
|------------------------------|----------------------------------|-------------------------|
| (A) Pressure vessel body     | (B) Bursting disk retaining plug | (C) Firing plug         |
| (D) Soft lead washer         | (E) Bursting disc                | (F) Side arm            |
| (G) Pressure transducer head | (H) Washer                       | (J) Insulated electrode |
| (K) Earthed electrode        | (L) Insulation                   | (M) Steel cone          |
| (N) Washer distorting groove |                                  |                         |

Figure 2

Support stand

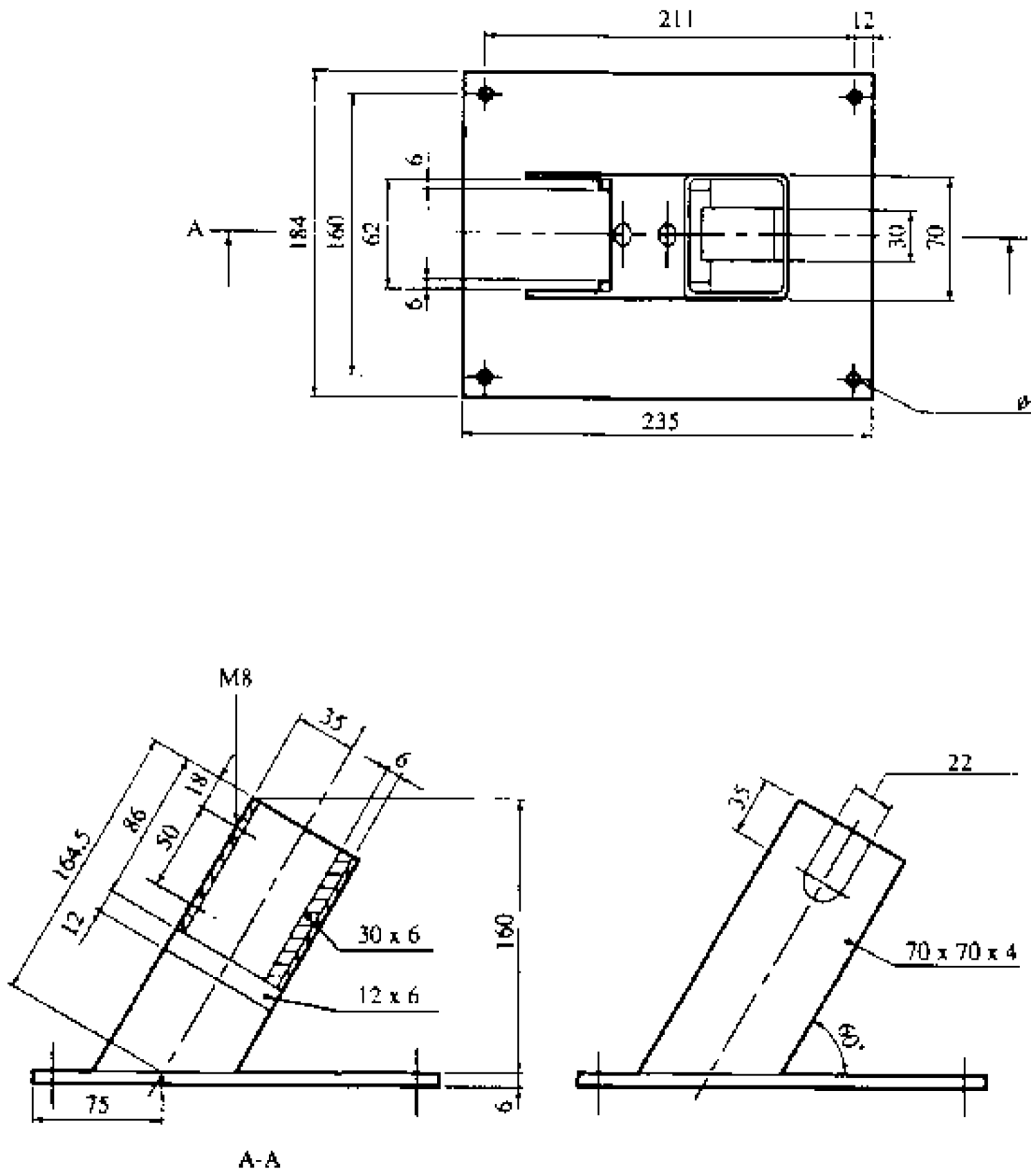
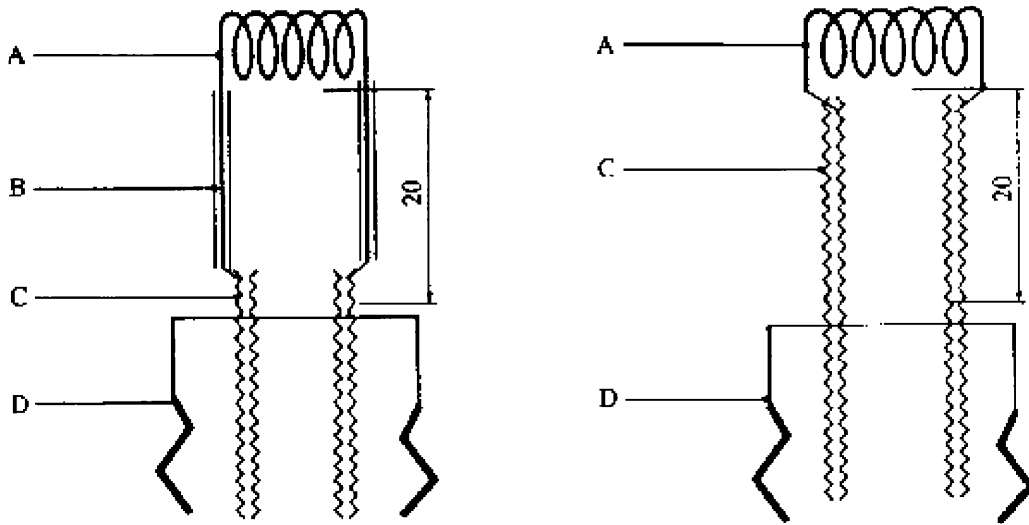

Figure 3

## Ignition System



(A) Ignition coil

(B) Insulation

(C) Electrodes

(D) Firing plug

Note: either of these configurations may be used.

---

## ANNEX 2B

## ‘B.1 bis. ACUTE ORAL TOXICITY - FIXED DOSE PROCEDURE

## 1. METHOD

This test method is equivalent to OECD TG 420 (2001)

## 1.1 INTRODUCTION

Traditional methods for assessing acute toxicity use death of animals as an endpoint. In 1984, a new approach to acute toxicity testing was suggested by the British Toxicology Society based on the administration at a series of fixed dose levels (1). The approach avoided using death of animals as an endpoint, and relied instead on the observation of clear signs of toxicity at one of a series of fixed dose levels. Following UK (2) and international (3) *in vivo* validation studies the procedure was adopted as a testing method in 1992. Subsequently, the statistical properties of the Fixed Dose Procedure have been evaluated using mathematical models in a series of studies (4)(5)(6). Together, the *in vivo* and modelling studies have demonstrated that the procedure is reproducible, uses fewer animals and causes less suffering than the traditional methods and is able to rank substances in a similar manner to the other acute toxicity testing methods.

Guidance on the selection of the most appropriate test method for a given purpose can be found in the Guidance Document on Acute Oral Toxicity Testing (7). This Guidance Document also contains additional information on the conduct and interpretation of Testing Method B.1bis.

It is a principle of the method that in the main study only moderately toxic doses are used, and that administration of doses that are expected to be lethal should be avoided. Also, doses that are known to cause marked pain and distress, due to corrosive or severely irritant actions, need not be administered. Moribund animals, or animals obviously in pain or showing signs of severe and enduring distress shall be humanely killed, and are considered in the interpretation of the test results in the same way as animals that died on test. Criteria for making the decision to kill moribund or severely suffering animals, and guidance on the recognition of predictable or impending death, are the subject of a separate Guidance Document (8).

The method provides information on the hazardous properties and allows the substance to be ranked and classified according to the Globally Harmonised System (GHS) for the classification of chemicals which cause acute toxicity (9).

The testing laboratory should consider all available information on the test substance prior to conducting the study. Such information will include the identity and chemical structure of the substance; its physico-chemical properties; the results of any other *in vitro* or *in vivo* toxicity tests on the substance; toxicological data on structurally related substances; and the anticipated use(s) of the substance. This information is necessary to satisfy all concerned that the test is relevant for the protection of human health, and will help in the selection of an appropriate starting dose.

## 1.2 DEFINITIONS

**Acute oral toxicity:** refers to those adverse effects occurring following oral administration of a single dose of a substance or multiple doses given within 24 hours.

**Delayed death:** means that an animal does not die or appear moribund within 48 hours but dies later during the 14-day observation period.

**Dose:** is the amount of test substance administered. Dose is expressed as weight of test substance per unit weight of test animal (e.g. mg/kg).

**Evident toxicity:** is a general term describing clear signs of toxicity following the administration of test substance (see (3) for examples) such that at the next highest fixed dose either severe pain and enduring signs of severe distress, moribund status (criteria are presented in the Humane Endpoints Guidance Document (8)), or probable mortality in most animals can be expected.

**GHS:** Globally Harmonised Classification System for Chemical Substances and Mixtures. A joint activity of OECD (human health and the environment), UN Committee of Experts on Transport of Dangerous Goods (physical-chemical properties) and ILO (hazard communication) and co-ordinated by the Interorganisation Programme for the Sound Management of Chemicals (IOMC).

**Impending death:** when moribund state or death is expected prior to the next planned time of observation. Signs indicative of this state in rodents could include convulsions, lateral position, recumbence, and tremor. (See the Humane Endpoint Guidance Document (8) for more details).

**LD<sub>50</sub> (median lethal dose):** is a statistically derived single dose of a substance that can be expected to cause death in 50 per cent of animals when administered by the oral route. The LD<sub>50</sub> value is expressed in terms of weight of test substance per unit weight of test animal (mg/kg).

**Limit dose:** refers to a dose at an upper limitation on testing (2 000 or 5 000 mg/kg).

**Moribund status:** being in a state of dying or inability to survive, even if treated. (See the Humane Endpoint Guidance Document (8) for more details).

**Predictable death:** presence of clinical signs indicative of death at a known time in the future before the planned end of the experiment, for example: inability to reach water or food. (See the Humane Endpoint Guidance Document (8) for more details).

### 1.3 PRINCIPLE OF THE TEST METHOD

Groups of animals of a single sex are dosed in a stepwise procedure using the fixed doses of 5, 50, 300 and 2 000 mg/kg (exceptionally an additional fixed dose of 5 000 mg/kg may be considered, see section 1.6.2). The initial dose level is selected on the basis of a sighting study as the dose expected to produce some signs of toxicity without causing severe toxic effects or mortality. Clinical signs and conditions associated with pain, suffering, and impending death, are described in detail in a separate OECD Guidance Document (8). Further groups of animals may be dosed at higher or lower fixed doses, depending on the presence or absence of signs of toxicity or mortality. This procedure continues until the dose causing evident toxicity or no more than one death is identified, or when no effects are seen at the highest dose or when deaths occur at the lowest dose.

### 1.4 DESCRIPTION OF THE TEST METHOD

#### 1.4.1 Selection of animal species

The preferred rodent species is the rat, although other rodent species may be used. Normally females are used (7). This is because literature surveys of conventional LD<sub>50</sub> tests show that usually there is little difference in sensitivity between the sexes, but in those cases where differences are observed, females are generally slightly more sensitive (10). However, if knowledge of the toxicological or toxicokinetic properties of structurally related chemicals indicates that males are likely to be more sensitive then this sex should be used. When the test is conducted in males, adequate justification should be provided.

Healthy young adult animals of commonly used laboratory strains should be employed. Females should be nulliparous and non-pregnant. Each animal, at the commencement of its dosing, should be between 8 and 12 weeks old and its weight should fall in an interval within  $\pm 20\%$  of the mean weight of any previously dosed animals.

#### 1.4.2 Housing and feeding conditions

The temperature of the experimental animal room should be 22°C ( $\pm 3^\circ\text{C}$ ). Although the relative humidity should be at least 30 % and preferably not exceed 70 % other than during room cleaning the aim should be 50-60 %. Lighting should be artificial, the sequence being 12 hours light, 12 hours dark. For feeding, conventional laboratory diets may be used with an unlimited supply of drinking water. Animals may be group-caged by dose, but the number of animals per cage must not interfere with clear observations of each animal.

#### 1.4.3 **Preparation of animals**

The animals are randomly selected, marked to permit individual identification, and kept in their cages for at least 5 days prior to the start of dosing to allow for acclimatisation to the laboratory conditions.

#### 1.4.4 **Preparation of doses**

In general test substances should be administered in a constant volume over the range of doses to be tested by varying the concentration of the dosing preparation. Where a liquid end product or mixture is to be tested however, the use of the undiluted test substance, i.e. at a constant concentration, may be more relevant to the subsequent risk assessment of that substance, and is a requirement of some regulatory authorities. In either case, the maximum dose volume for administration must not be exceeded. The maximum volume of liquid that can be administered at one time depends on the size of the test animal. In rodents, the volume should not normally exceed 1ml/100g of body weight: however in the case of aqueous solutions 2 ml/100g body weight can be considered. With respect to the formulation of the dosing preparation, the use of an aqueous solution/suspension/emulsion is recommended wherever possible, followed in order of preference by a solution/suspension/emulsion in oil (e.g. corn oil) and then possibly solution in other vehicles. For vehicles other than water the toxicological characteristics of the vehicle should be known. Doses must be prepared shortly prior to administration unless the stability of the preparation over the period during which it will be used is known and shown to be acceptable.

### 1.5 PROCEDURE

#### 1.5.1 **Administration of doses**

The test substance is administered in a single dose by gavage using a stomach tube or a suitable intubation canula. In the unusual circumstance that a single dose is not possible, the dose may be given in smaller fractions over a period not exceeding 24 hours.

Animals should be fasted prior to dosing (e.g. with the rat, food but not water should be withheld overnight; with the mouse, food but not water should be withheld for 3-4 hours). Following the period of fasting, the animals should be weighed and the test substance administered. After the substance has been administered, food may be withheld for a further 3-4 hours in rats or 1-2 hours in mice. Where a dose is administered in fractions over a period of time, it may be necessary to provide the animals with food and water depending on the length of the period.

#### 1.5.2 **Sighting study**

The purpose of the sighting study is to allow selection of the appropriate starting dose for the main study. The test substance is administered to single animals in a sequential manner following the flow charts in Annex 1. The sighting study is completed when a decision on the starting dose for the main study can be made (or if a death is seen at the lowest fixed dose).

The starting dose for the sighting study is selected from the fixed dose levels of 5, 50, 300 and 2 000 mg/kg as a dose expected to produce evident toxicity based, when possible, on evidence from *in vivo* and *in vitro* data from the same chemical and from structurally related chemicals. In the absence of such information, the starting dose will be 300 mg/kg.

A period of at least 24 hours will be allowed between the dosing of each animal. All animals should be observed for at least 14 days.

Exceptionally, and only when justified by specific regulatory needs, the use of an additional upper fixed dose level of 5 000 mg/kg may be considered (see Annex 3). For reasons of animal welfare concern, testing of animals in GHS Category 5 ranges (2 000-5 000 mg/kg) is discouraged and should only be considered when there is a strong likelihood that the results of such a test have a direct relevance for protecting human or animal health or the environment.

In cases where an animal tested at the lowest fixed dose level (5mg/kg) in the sighting study dies, the normal procedure is to terminate the study and assign the substance to GHS Category 1 (as shown in Annex 1). However, if further confirmation of the classification is required, an optional supplementary procedure may be conducted, as follows. A second animal is dosed at 5mg/kg. If this second animal dies, then GHS Category 1 will be confirmed and the study will be immediately terminated. If the second animal survives, then a maximum of three additional animals will be dosed at 5mg/kg. Because there will be a high risk of mortality, these animals should be dosed in a sequential manner to protect animal



welfare. The time interval between dosing each animal should be sufficient to establish that the previous animal is likely to survive. If a second death occurs, the dosing sequence will be immediately terminated and no further animals will be dosed. Because the occurrence of a second death (irrespective of the number of animals tested at the time of termination) falls into outcome A (2 or more deaths), the classification rule of Annex 2 at the 5mg/kg fixed dose is followed (Category 1 if there are 2 or more deaths or Category 2 if there is no more than 1 death). In addition, Annex 4 gives guidance on the classification in the EU system until the new GHS is implemented.

### 1.5.3 **Main study**

#### 1.5.3.1 *Numbers of animals and dose levels*

The action to be taken following testing at the starting dose level is indicated by the flow charts in Annex 2. One of three actions will be required; either stop testing and assign the appropriate hazard classification class, test at a higher fixed dose or test at a lower fixed dose. However, to protect animals, a dose level that caused death in the sighting study will not be revisited in the main study (see Annex 2). Experience has shown that the most likely outcome at the starting dose level will be that the substance can be classified and no further testing will be necessary.

A total of five animals of one sex will normally be used for each dose level investigated. The five animals will be made up of one animal from the sighting study dosed at the selected dose level together with an additional four animals (except, unusually, if a dose level used on the main study was not included in the sighting study).

The time interval between dosing at each level is determined by the onset, duration, and severity of toxic signs. Treatment of animals at the next dose should be delayed until one is confident of survival of the previously dosed animals. A period of 3 or 4 days between dosing at each dose level is recommended, if needed, to allow for the observation of delayed toxicity. The time interval may be adjusted as appropriate, e.g., in case of inconclusive response.

When the use of an upper fixed dose of 5 000 mg/kg is considered, the procedure outlined in Annex 3 should be followed (see also section 1.6.2).

#### 1.5.3.2 *Limit test*

The limit test is primarily used in situations where the experimenter has information indicating that the test material is likely to be nontoxic, i.e., having toxicity only above regulatory limit doses. Information about the toxicity of the test material can be gained from knowledge about similar tested compounds or similar tested mixtures or products, taking into consideration the identity and percentage of components known to be of toxicological significance. In those situations where there is little or no information about its toxicity, or in which the test material is expected to be toxic, the main test should be performed.

Using the normal procedure, a sighting study starting dose of 2 000 mg/kg (or exceptionally 5 000 mg/kg) followed by dosing of a further four animals at this level serves as a limit test for this guideline.

### 1.6 OBSERVATIONS

Animals are observed individually after dosing at least once during the first 30 minutes, periodically during the first 24 hours, with special attention given during the first 4 hours, and daily thereafter, for a total of 14 days, except where they need to be removed from the study and humanely killed for animal welfare reasons or are found dead. However, the duration of observation should not be fixed rigidly. It should be determined by the toxic reactions, time of onset and length of recovery period, and may thus be extended when considered necessary. The times at which signs of toxicity appear and disappear are important, especially if there is a tendency for toxic signs to be delayed (11). All observations are systematically recorded, with individual records being maintained for each animal.

Additional observations will be necessary if the animals continue to display signs of toxicity. Observations should include changes in skin and fur, eyes and mucous membranes, and also respiratory, circulatory, autonomic and central nervous systems, and somatomotor activity and behaviour pattern. Attention should be directed to observations of tremors, convulsions, salivation, diarrhoea, lethargy, sleep and coma. The principles and criteria summarised in the Humane Endpoints Guidance Document should be taken

into consideration (8). Animals found in a moribund condition and animals showing severe pain or enduring signs of severe distress should be humanely killed. When animals are killed for humane reasons or found dead, the time of death should be recorded as precisely as possible.

#### 1.6.1 **Body weight**

Individual weights of animals should be determined shortly before the test substance is administered and at least weekly thereafter. Weight changes should be calculated and recorded. At the end of the test surviving animals are weighed and then humanely killed.

#### 1.6.2 **Pathology**

All test animals (including those that die during the test or are removed from the study for animal welfare reasons) should be subjected to gross necropsy. All gross pathological changes should be recorded for each animal. Microscopic examination of organs showing evidence of gross pathology in animals surviving 24 or more hours after the initial dosing may also be considered because it may yield useful information.

### 2. **DATA**

Individual animal data should be provided. Additionally, all data should be summarised in tabular form, showing for each test group the number of animals used, the number of animals displaying signs of toxicity, the number of animals found dead during the test or killed for humane reasons, time of death of individual animals, a description and the time course of toxic effects and reversibility, and necropsy findings.

### 3. **REPORTING**

#### 3.1 Test report

The test report must include the following information, as appropriate:

Test substance:

- physical nature, purity, and, where relevant, physico-chemical properties (including isomerisation);
- identification data, including CAS number.

Vehicle (if appropriate):

- justification for choice of vehicle, if other than water.

Test animals:

- species/strain used;
- microbiological status of the animals, when known;
- number, age and sex of animals (including, where appropriate, a rationale for use of males instead of females);
- source, housing conditions, diet etc.;

Test conditions:

- details of test substance formulation, including details of the physical form of the material administered;
- details of the administration of the test substance including dosing volumes and time of dosing;
- details of food and water quality (including diet type/source, water source);
- the rationale for the selection of the starting dose.

## Results:

- tabulation of response data and dose level for each animal (i.e. animals showing signs of toxicity including mortality, nature, severity and duration of effects);
- tabulation of body weight and body weight changes;
- individual weights of animals at the day of dosing, in weekly intervals thereafter, and at time of death or sacrifice;
- date and time of death if prior to scheduled sacrifice;
- time course of onset of signs of toxicity and whether these were reversible for each animal;
- necropsy findings and histopathological findings for each animal, if available.

Discussion and interpretation of results.

Conclusions.

## 4.

**REFERENCES**

- (1) British Toxicology Society Working Party on Toxicity (1984). Special report: a new approach to the classification of substances and preparations on the basis of their acute toxicity. *Human Toxicol.*, 3, 85-92.
- (2) Van den Heuvel, M.J., Dayan, A.D. and Shillaker, R.O. (1987). Evaluation of the BTS approach to the testing of substances and preparations for their acute toxicity. *Human Toxicol.*, 6, 279-291.
- (3) Van den Heuvel, M.J., Clark, D.G., Fielder, R.J., Koundakjian, P.P., Oliver, G.J.A., Pelling, D., Tomlinson, N.J. and Walker, A.P. (1990). The international validation of a fixed-dose procedure as an alternative to the classical LD<sub>50</sub> test. *Fd. Chem. Toxicol.* 28, 469-482.
- (4) Whitehead, A. and Curnow, R.N. (1992). Statistical evaluation of the fixed-dose procedure. *Fd. Chem. Toxicol.*, 30, 313-324.
- (5) Stallard, N. and Whitehead, A. (1995). Reducing numbers in the fixed-dose procedure. *Human Exptl. Toxicol.* 14, 315-323. *Human Exptl. Toxicol.*
- (6) Stallard, N., Whitehead, A. and Ridgeway, P. (2002). Statistical evaluation of the revised fixed dose procedure. *Hum. Exp. Toxicol.*, 21, 183-196.
- (7) OECD (2001). Guidance Document on Acute Oral Toxicity Testing. Environmental Health and Safety Monograph Series on Testing and Assessment N. 24. Paris
- (8) OECD (2000). Guidance Document on the Recognition, Assessment and Use of Clinical Signs as Humane Endpoints for Experimental Animals Used in Safety Evaluation. Environmental Health and Safety Monograph Series on Testing and Assessment N. 19.
- (9) OECD (1998). Harmonised Integrated Hazard Classification for Human Health and Environmental Effects of Chemical Substances as endorsed by the 28th Joint Meeting of the Chemicals Committee and the Working Party on Chemicals in November 1998, Part 2, p.11 [<http://webnet1.oecd.org/oecd/pages/home/displaygeneral/0,3380,EN-documents-521-14-no-24-no-0,FF.html>].
- (10) Lipnick, R.L., Cotruvo, J.A., Hill, R.N., Bruce, R.D., Stitzel, K.A., Walker, A.P., Chu, I., Goddard, M., Segal, L., Springer, J.A. and Myers, R.C. (1995). Comparison of the Up-and-Down, Conventional LD<sub>50</sub>, and Fixed-Dose Acute Toxicity Procedures. *Fd. Chem. Toxicol.* 33, 223-231.
- (11) Chan P.K. and A.W. Hayes (1994) Chapter 16 Acute Toxicity and Eye Irritation . In: Principles and Methods of Toxicology . 3<sup>rd</sup> Edition. A.W. Hayes , Editor. Raven Press, Ltd. New York, USA.

ANNEX 1: FLOW CHART FOR THE SIGHTING STUDY

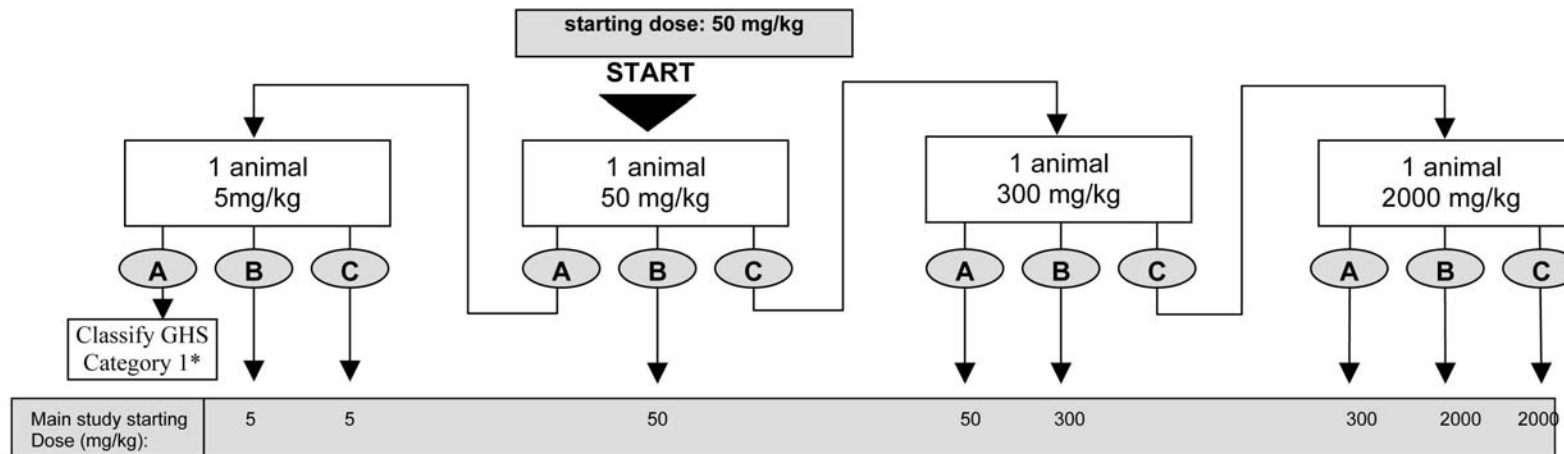
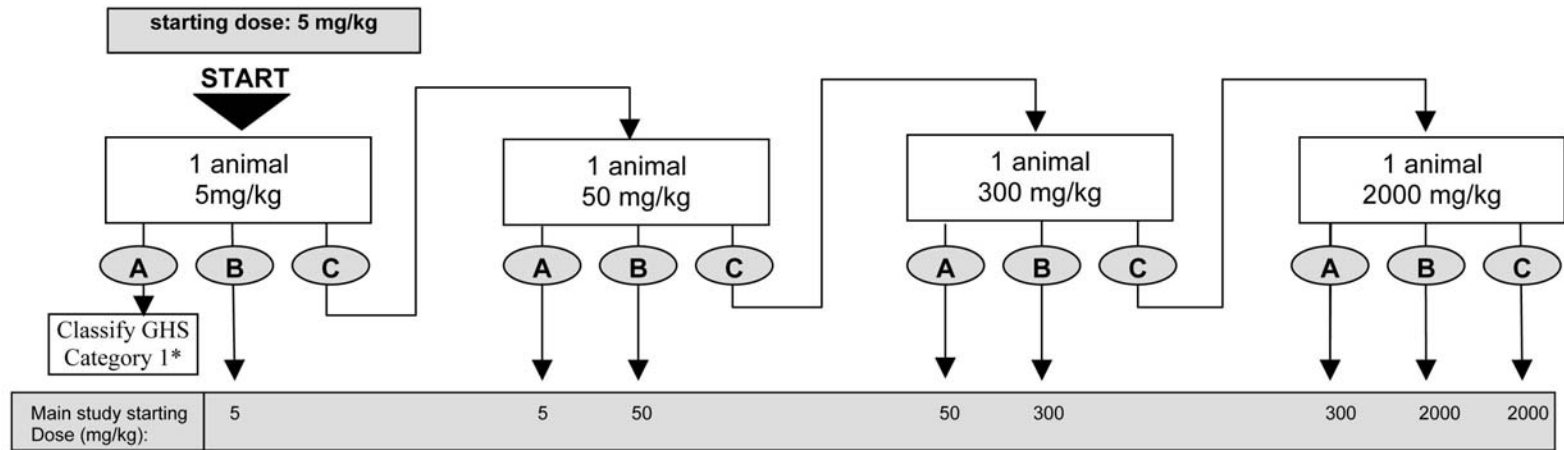

**Outcome**

**A** death

**B** evident toxicity

**C** no evident toxicity and no death

\* for outcome **A** at 5 mg/kg there is an optional supplementary procedure to confirm the GHS classification: see section 1.5.2

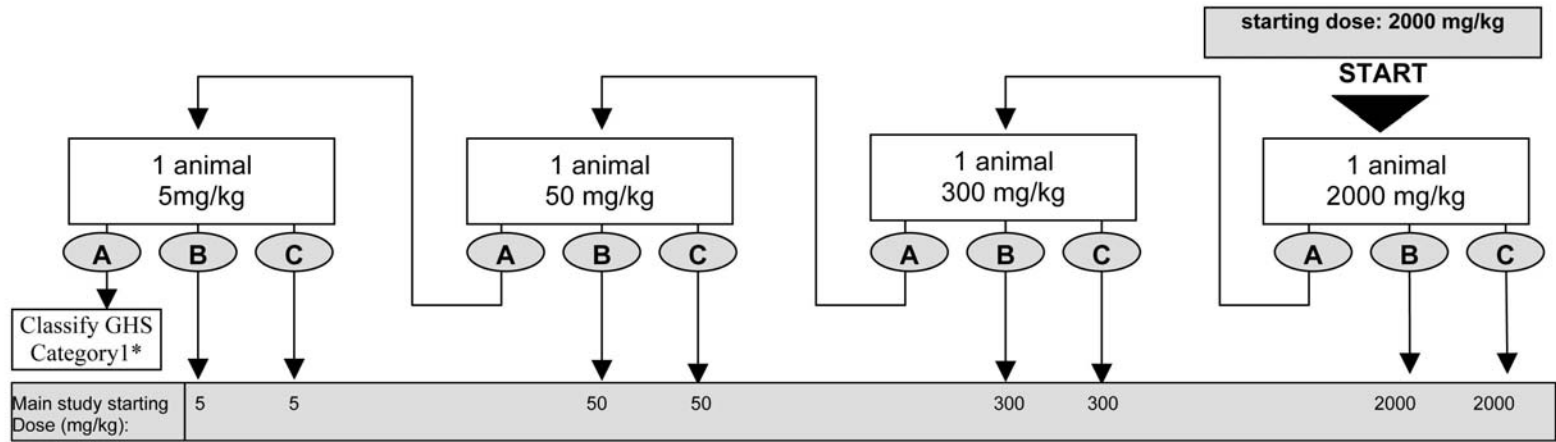
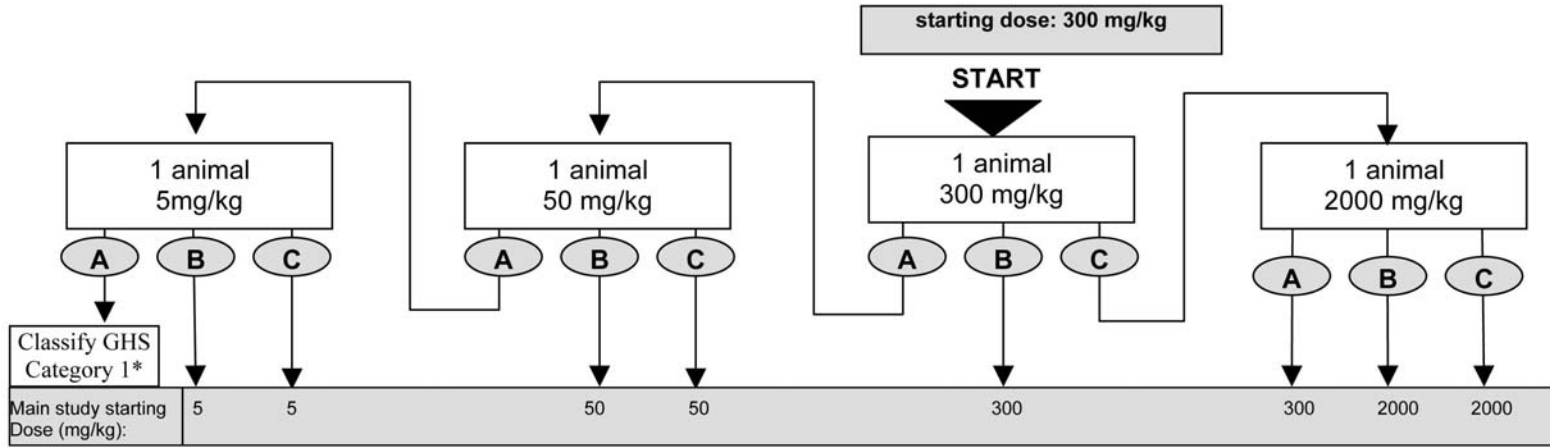

**Outcome**

**A** death

**B** evident toxicity

**C** no evident toxicity and no death

\* for outcome **A** at 5 mg/kg there is an optional supplementary procedure to confirm the GHS classification: see section 1.5.2.

ANNEX 2: FLOW CHART FOR THE MAIN STUDY

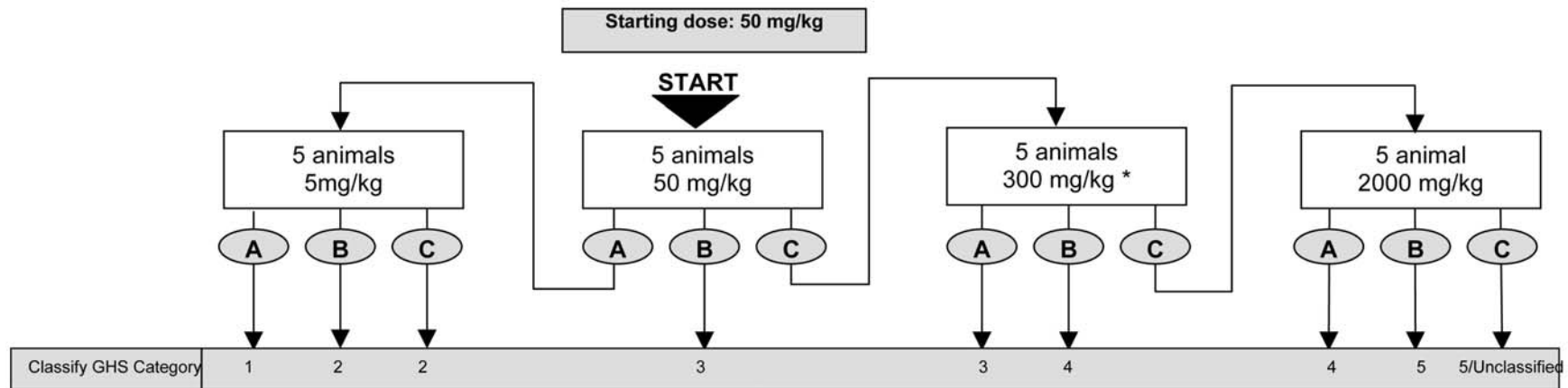
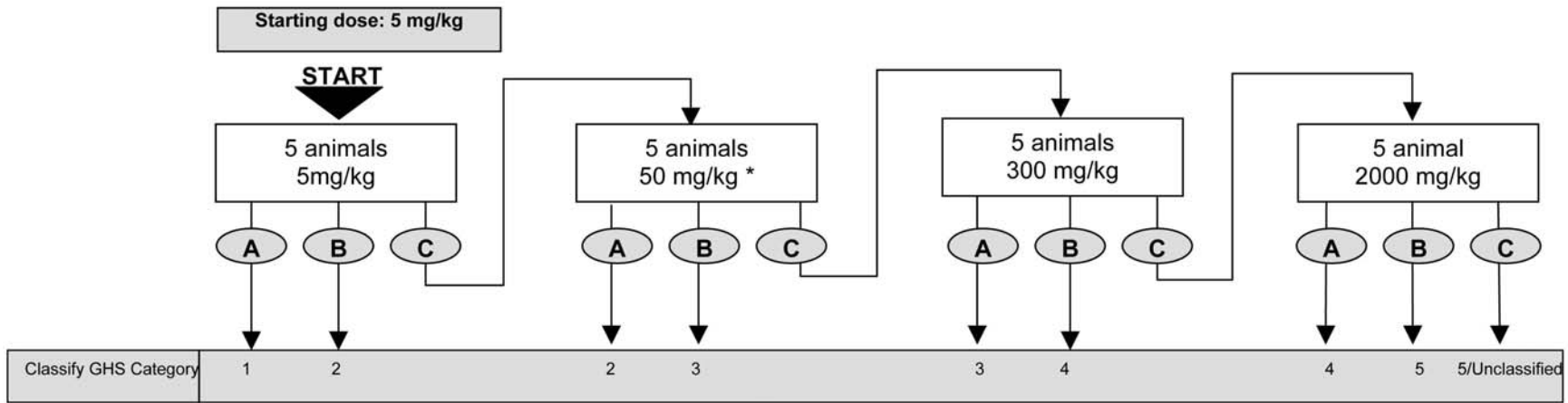

**Outcome**

**A** ≥ 2 deaths

**B** ≥ 1 with evident toxicity and / or 1 death

**C** No evident toxicity and no death

**Group size**

The 5 animals in each main study group will include any animal tested at that dose level in the sighting study

**\*Animal welfare override**

If this dose level caused death in the sighting study, then no further animals will be tested. Go directly to outcome **A**

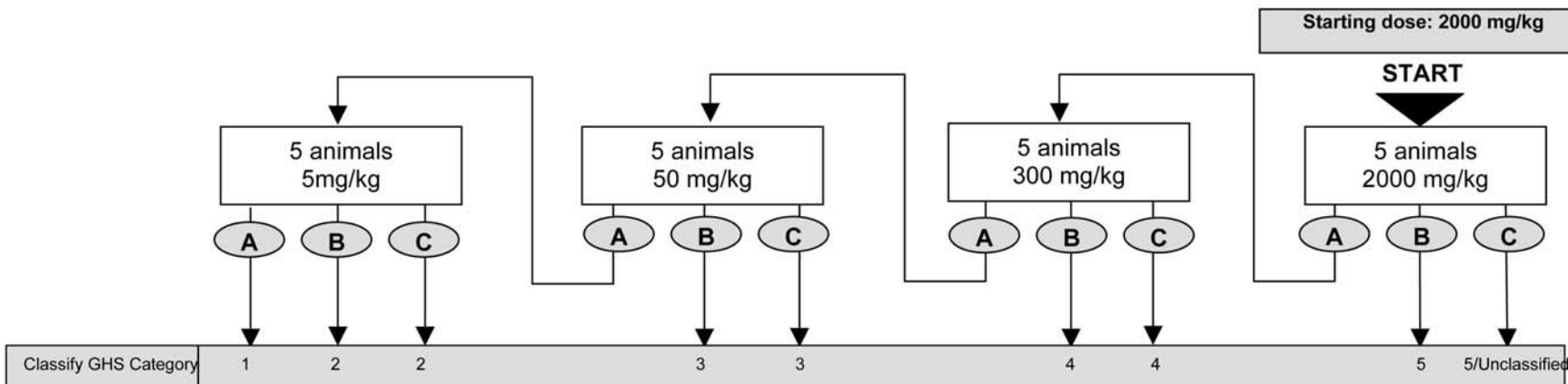
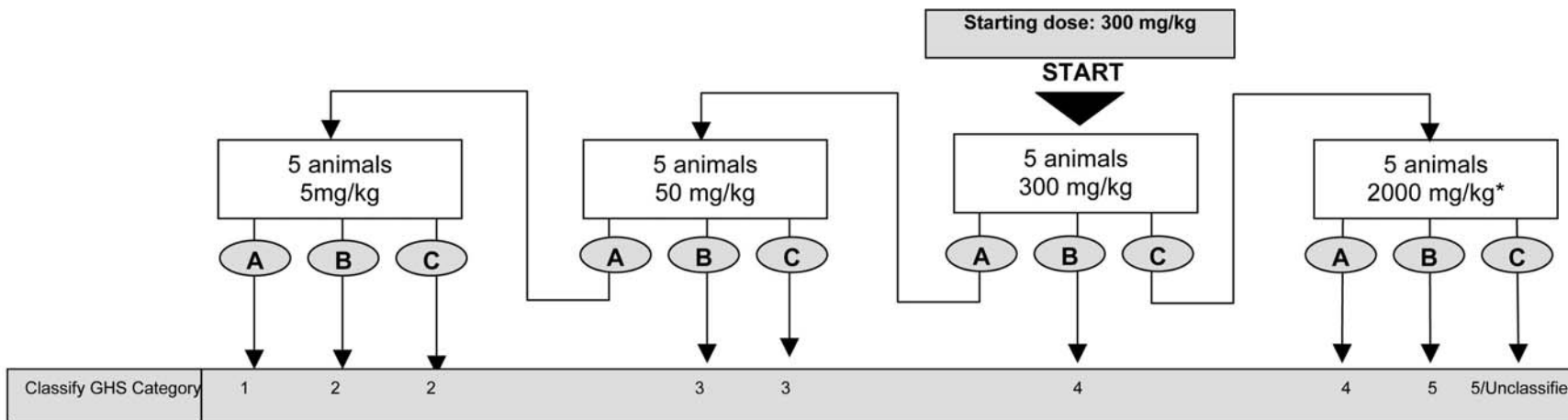

**Outcome**

**A** ≥ 2 deaths

**B** ≥ 1 with evident toxicity and / or 1 death

**C** No evident toxicity and no death

**Group size**

The 5 animals in each main study group will include any animal tested at that dose level in the sighting study

**\*Animal welfare override**

If this dose level caused death in the sighting study, then no further animals will be tested. Go directly to outcome **A**

## ANNEX 3

**CRITERIA FOR CLASSIFICATION OF TEST SUBSTANCES WITH EXPECTED LD<sub>50</sub> VALUES EXCEEDING 2 000 MG/KG WITHOUT THE NEED FOR TESTING.**

Criteria for hazard Category 5 are intended to enable the identification of test substances which are of relatively low acute toxicity hazard but which, under certain circumstances may present a danger to vulnerable populations. These substances are anticipated to have an oral or dermal LD<sub>50</sub> in the range of 2 000-5 000 mg/kg or equivalent doses for other routes. Test substances could be classified in the hazard category defined by: 2 000 mg/kg < LD<sub>50</sub> < 5 000 mg/kg (Category 5 in the GHS) in the following cases:

- a) if directed to this category by any of the testing schemes of Annex 2, based on mortality incidences
- b) if reliable evidence is already available that indicates the LD<sub>50</sub> to be in the range of Category 5 values; or other animal studies or toxic effects in humans indicate a concern for human health of an acute nature.
- c) through extrapolation, estimation or measurement of data if assignment to a more hazardous class is not warranted, and
  - reliable information is available indicating significant toxic effects in humans, or
  - any mortality is observed when tested up to Category 4 values by the oral route, or
  - where expert judgement confirms significant clinical signs of toxicity, when tested up to Category 4 values, except for diarrhoea, piloerection or an ungroomed appearance, or
  - where expert judgement confirms reliable information indicating the potential for significant acute effects from the other animal studies.

**TESTING AT DOSES ABOVE 2 000 MG/KG**

Exceptionally, and only when justified by specific regulatory needs, the use of an additional upper fixed dose level of 5 000 mg/kg may be considered. Recognising the need to protect animal welfare, testing at 5 000 mg/kg is discouraged and should only be considered when there is a strong likelihood that the results of such a test would have a direct relevance for protecting animal or human health (9).

**Sighting Study**

The decision rules governing the sequential procedure presented in Annex 1 are extended to include a 5 000 mg/kg dose level. Thus, when a sighting study starting dose of 5 000 mg/kg is used outcome A (death) will require a second animal to be tested at 2 000 mg/kg; outcomes B and C (evident toxicity or no toxicity) will allow the selection of 5 000 mg/kg as the main study starting dose. Similarly, if a starting dose other than 5 000 mg/kg is used then testing will progress to 5 000 mg/kg in the event of outcomes B or C at 2 000 mg/kg; a subsequent 5 000 mg/kg outcome A will dictate a main study starting dose of 2 000 mg/kg and outcomes B and C will dictate a main study starting dose of 5 000 mg/kg.

**Main Study**

The decision rules governing the sequential procedure presented in Annex 2 are extended to include a 5 000 mg/kg dose level. Thus, when a main study starting dose of 5 000 mg/kg is used, outcome A (≥2 deaths) will require the testing of a second group at 2 000 mg/kg; outcome B (evident toxicity and/or ≤1 death) or C (no toxicity) will result in the substance being unclassified according to GHS. Similarly, if a starting dose other than 5 000 mg/kg is used then testing will progress to 5 000 mg/kg in the event of outcome C at 2 000 mg/kg; a subsequent 5 000 mg/kg outcome A will result in the substance being assigned to GHS Category 5 and outcomes B or C will lead to the substance being unclassified.



ANNEX 4

TEST METHOD B.1 bis – Guidance on classification according to the EU scheme to cover the transition period until full implementation of the Globally Harmonised Classification System (GHS)  
(taken from reference (8))

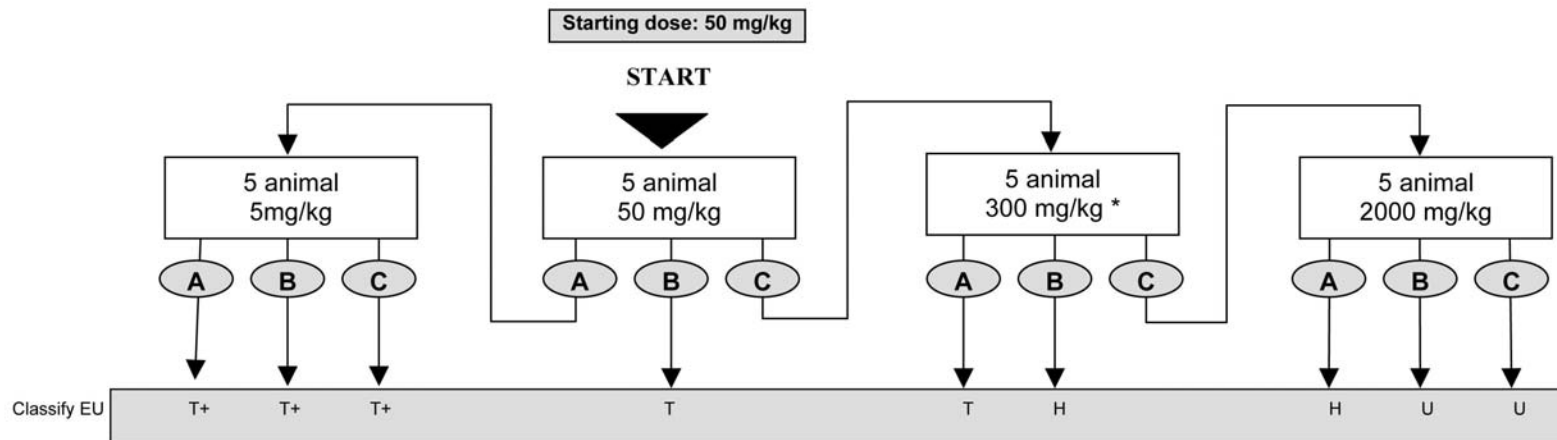
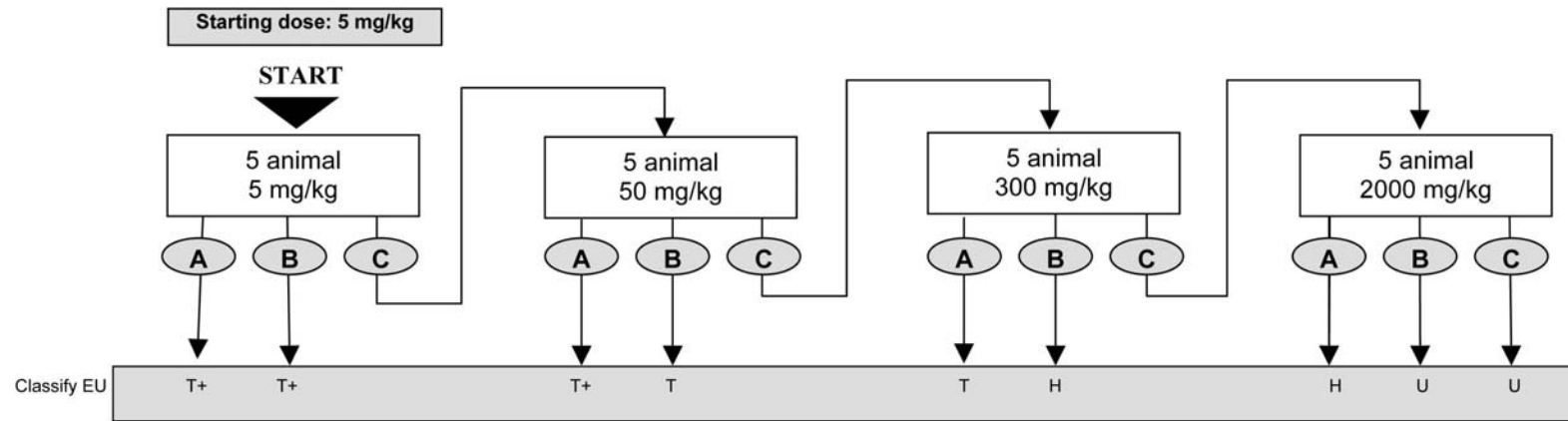

| Outcome  |  |
|----------|--|
| <b>A</b> | ≥ 2 deaths                               |
| <b>B</b> | ≥ 1 with evident toxicity and/or 1 death |
| <b>C</b> | No evident toxicity and no deaths        |

T+ = very toxic  
T = toxic  
H = harmful  
U = unclassified

\* **Animal welfare override** If this dose level caused death in the sighting study, then no further animals will be tested. Go directly to outcome **A**

**Group size** The 5 animals in each main study group will include any animal tested at that dose level in the study

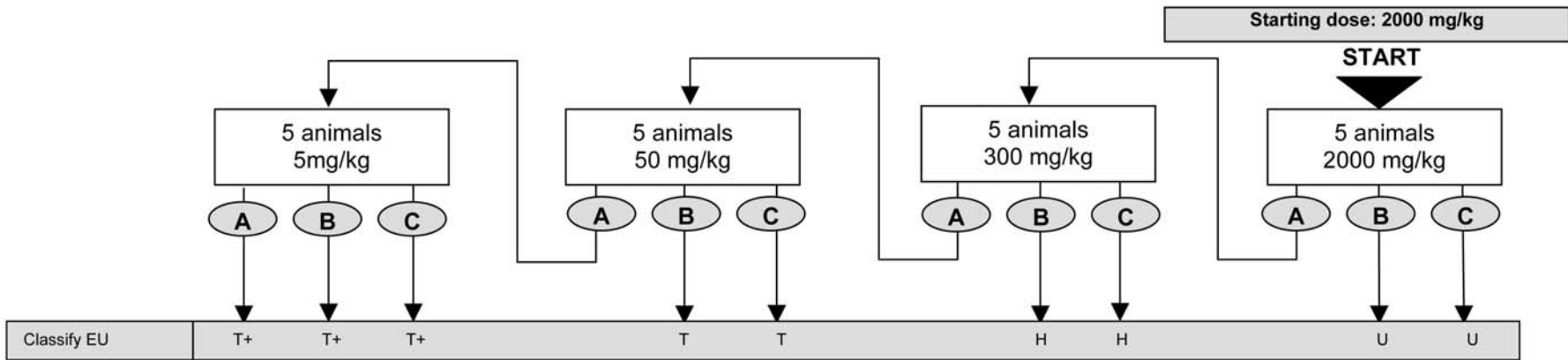
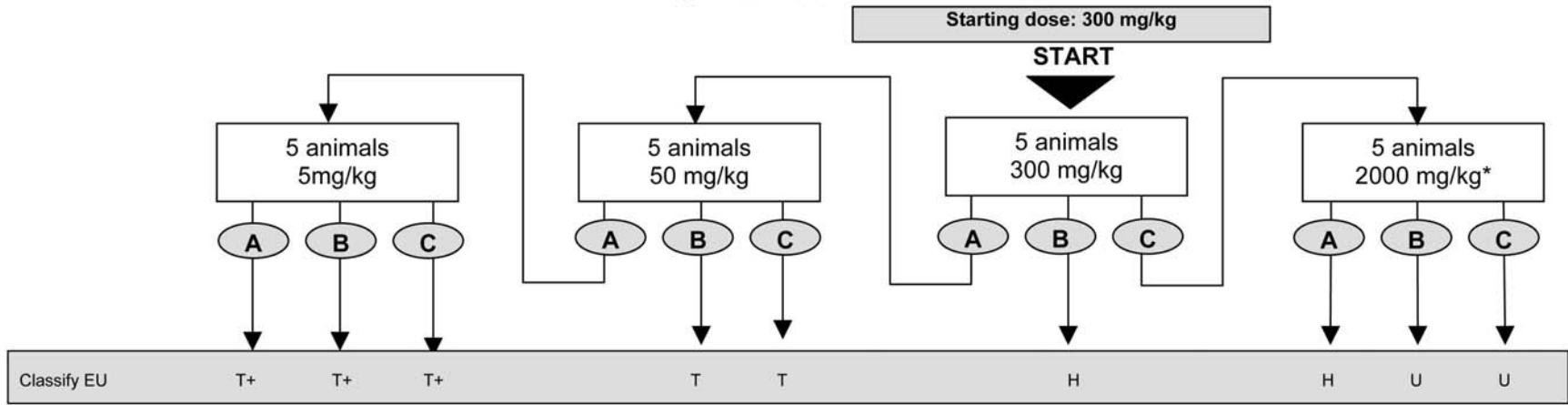

**Outcome**

**A** ≥ 2 deaths

**B** ≥ 1 with evident toxicity and / or 1 death

**C** No evident toxicity and no death

**T+** = very toxic  
**T** = toxic  
**H** = harmful  
**U** = unclassified

**Group size**

The 5 animals in each main study group will include any animal tested at that dose level in the sighting study

**\*Animal welfare override**

If this dose level caused death in the sighting study, then no further animals will be tested. Go directly to outcome **A**

## ANNEX 2C

## B.1 tris. ACUTE ORAL TOXICITY - ACUTE TOXIC CLASS METHOD

## 1. METHOD

This test method is equivalent to OECD TG 423 (2001)

## 1.1 INTRODUCTION

The acute toxic class method (1) set out in this test is a stepwise procedure with the use of 3 animals of a single sex per step. Depending on the mortality and/or the moribund status of the animals, on average 2-4 steps may be necessary to allow judgement on the acute toxicity of the test substance. This procedure is reproducible, uses very few animals and is able to rank substances in a similar manner to the other acute toxicity testing methods. The acute toxic class method is based on biometric evaluations (2)(3)(4)(5) with fixed doses, adequately separated to enable a substance to be ranked for classification purposes and hazard assessment. The method as adopted in 1996 was extensively validated *in vivo* against LD<sub>50</sub> data obtained from the literature, both nationally (6) and internationally (7).

Guidance on the selection of the most appropriate test method for a given purpose can be found in the Guidance Document on Acute Oral Toxicity Testing (8). This Guidance Document also contains additional information on the conduct and interpretation of testing method B.1 tris.

Test substances, at doses that are known to cause marked pain and distress due to corrosive or severely irritant actions, need not be administered. Moribund animals, or animals obviously in pain or showing signs of severe and enduring distress shall be humanely killed, and are considered in the interpretation of the test results in the same way as animals that died on test. Criteria for making the decision to kill moribund or severely suffering animals, and guidance on the recognition of predictable or impending death, are the subject of a separate Guidance Document (9).

The method uses pre-defined doses and the results allow a substance to be ranked and classified according to the Globally Harmonised System for the classification of chemicals which cause acute toxicity (10).

In principle, the method is not intended to allow the calculation of a precise LD<sub>50</sub>, but does allow for the determination of defined exposure ranges where lethality is expected since death of a proportion of the animals is still the major endpoint of this test. The method allows for the determination of an LD<sub>50</sub> value only when at least two doses result in mortality higher than 0 % and lower than 100 %. The use of a selection of pre-defined doses, regardless of test substance, with classification explicitly tied to number of animals observed in different states improves the opportunity for laboratory to laboratory reporting consistency and repeatability.

The testing laboratory should consider all available information on the test substance prior to conducting the study. Such information will include the identity and chemical structure of the substance; its physico-chemical properties; the result of any other *in vivo* or *in vitro* toxicity tests on the substance; toxicological data on the structurally related substances; and the anticipated use(s) of the substance. This information is necessary to satisfy all concerned that the test is relevant for the protection of human health and will help in the selection of the most appropriate starting dose.

## 1.2 DEFINITIONS

**Acute oral toxicity:** refers to those adverse effects occurring following oral administration of a single dose of a substance or multiple doses given within 24 hours.

**Delayed death:** means that an animal does not die or appear moribund within 48 hours but dies later during the 14-day observation period.

**Dose:** is the amount of test substance administered. Dose is expressed as weight of test substance per unit weight of test animal (e.g. mg/kg).

**GHS:** Globally Harmonised Classification System for Chemical Substances and Mixtures. A joint activity of OECD (human health and the environment), UN Committee of Experts on Transport of Dangerous Goods (physical-chemical properties) and ILO (hazard communication) and co-ordinated by the Interorganisation Programme for the Sound Management of Chemicals (IOMC).

**Impending death:** when moribund state or death is expected prior to the next planned time of observation. Signs indicative of this state in rodents could include convulsions, lateral position, recumbence, and tremor (See the Humane Endpoint Guidance Document (9) for more details).

**LD<sub>50</sub> (median lethal oral dose):** is a statistically derived single dose of a substance that can be expected to cause death in 50 per cent of animals when administered by the oral route. The LD<sub>50</sub> value is expressed in terms of weight of test substance per unit weight of test animal (mg/kg).

**Limit dose:** refers to a dose at an upper limitation on testing (2 000 or 5 000 mg/kg).

**Moribund status:** being in a state of dying or inability to survive, even if treated (See the Humane Endpoint Guidance Document (9) for more details).

**Predictable death:** presence of clinical signs indicative of death at a known time in the future before the planned end of the experiment; for example: inability to reach water or food. (See the Humane Endpoint Guidance Document (9) for more details).

### 1.3 PRINCIPLE OF THE TEST

It is the principle of the test that, based on a stepwise procedure with the use of a minimum number of animals per step, sufficient information is obtained on the acute toxicity of the test substance to enable its classification. The substance is administered orally to a group of experimental animals at one of the defined doses. The substance is tested using a stepwise procedure, each step using three animals of a single sex (normally females). Absence or presence of compound-related mortality of the animals dosed at one step will determine the next step, i.e.:

- no further testing is needed,
- dosing of three additional animals, with the same dose
- dosing of three additional animals at the next higher or the next lower dose level.

Details of the test procedure are described in Annex 1. The method will enable a judgement with respect to classifying the test substance to one of a series of toxicity classes defined by fixed LD<sub>50</sub> cut-off values.

### 1.4 DESCRIPTION OF THE METHOD

#### 1.4.1 Selection of animal species

The preferred rodent species is the rat, although other rodent species may be used. Normally females are used (9). This is because literature surveys of conventional LD<sub>50</sub> tests show that, although there is little difference in sensitivity between the sexes, in those cases where differences are observed females are generally slightly more sensitive (11). However if knowledge of the toxicological or toxicokinetic properties of structurally related chemicals indicates that males are likely to be more sensitive, then this sex should be used. When the test is conducted in males adequate justification should be provided.

Healthy young adult animals of commonly used laboratory strains should be employed. Females should be nulliparous and non-pregnant. Each animal, at the commencement of its dosing, should be between 8 and 12 weeks old and its weight should fall in an interval within  $\pm 20\%$  of the mean weight of any previously dosed animals.

#### 1.4.2 **Housing and feeding conditions**

The temperature in the experimental animal room should be 22°C ( $\pm$  3°C). Although the relative humidity should be at least 30 % and preferably not exceed 70 % other than during room cleaning the aim should be 50-60 %. Lighting should be artificial, the sequence being 12 hours light, 12 hours dark. For feeding, conventional laboratory diets may be used with an unlimited supply of drinking water. Animals may be group-caged by dose, but the number of animals per cage must not interfere with clear observations of each animal.

#### 1.4.3 **Preparation of animals**

The animals are randomly selected, marked to permit individual identification, and kept in their cages for at least 5 days prior to dosing to allow for acclimatisation to the laboratory conditions.

#### 1.4.4 **Preparation of doses**

In general test substances should be administered in a constant volume over the range of doses to be tested by varying the concentration of the dosing preparation. Where a liquid end product or mixture is to be tested however, the use of the undiluted test substance, i.e. at a constant concentration, may be more relevant to the subsequent risk assessment of that substance, and is a requirement of some regulatory authorities. In either case, the maximum dose volume for administration must not be exceeded. The maximum volume of liquid that can be administered at one time depends on the size of the test animal. In rodents, the volume should not normally exceed 1ml/100g of body weight: however in the case of aqueous solutions 2 ml/100g body weight can be considered. With respect to the formulation of the dosing preparation, the use of an aqueous solution/suspension/emulsion is recommended wherever possible, followed in order of preference by a solution/suspension/emulsion in oil (e.g. corn oil) and then possibly solution in other vehicles. For vehicles other than water the toxicological characteristics of the vehicle should be known. Doses must be prepared shortly prior to administration unless the stability of the preparation over the period during which it will be used is known and shown to be acceptable.

### 1.5 PROCEDURE

#### 1.5.1 **Administration of doses**

The test substance is administered in a single dose by gavage using a stomach tube or a suitable intubation canula. In the unusual circumstance that a single dose is not possible, the dose may be given in smaller fractions over a period not exceeding 24 hours.

Animals should be fasted prior to dosing (e.g. with the rat, food but not water should be withheld overnight, with the mouse, food but not water should be withheld for 3-4 hours). Following the period of fasting, the animals should be weighed and the test substance administered. After the substance has been administered, food may be withheld for a further 3-4 hours in rats or 1-2 hours in mice. Where a dose is administered in fractions over a period it may be necessary to provide the animals with food and water depending on the length of the period.

#### 1.5.2 **Number of animals and dose levels**

Three animals are used for each step. The dose level to be used as the starting dose is selected from one of four fixed levels, 5, 50, 300 and 2 000 mg/kg body weight. The starting dose level should be that which is most likely to produce mortality in some of the dosed animals. The flow charts of Annex 1 describe the procedure that should be followed for each of the starting doses. In addition, Annex 4 gives guidance on the classification in the EU system until the new GHS is implemented.

When available information suggests that mortality is unlikely at the highest starting dose level (2 000 mg/kg body weight), then a limit test should be conducted. When there is no information on a substance to be tested, for animal welfare reasons it is recommended to use the starting dose of 300 mg/kg body weight.

The time interval between treatment groups is determined by the onset, duration, and severity of toxic signs. Treatment of animals at the next dose, should be delayed until one is confident of survival of the previously dosed animals.

Exceptionally, and only when justified by specific regulatory needs, the use of additional upper dose level of 5 000 mg/kg body weight may be considered (see Annex 2). For reasons of animal welfare concern, testing of animals in GHS Category 5 ranges (2 000-5 000 mg/kg) is discouraged and should only be considered when there is a strong likelihood that the results of such a test would have a direct relevance for protecting human or animal health or the environment.

### 1.5.3 **Limit test**

The limit test is primarily used in situations where the experimenter has information indicating that the test material is likely to be nontoxic, i.e., having toxicity only above regulatory limit doses. Information about the toxicity of the test material can be gained from knowledge about similar tested compounds or similar tested mixtures or products, taking into consideration the identity and percentage of components known to be of toxicological significance. In those situations where there is little or no information about its toxicity, or in which the test material is expected to be toxic, the main test should be performed.

A limit test at one dose level of 2 000 mg/kg body weight may be carried out with six animals (three animals per step). Exceptionally a limit test at one dose level of 5000 mg/kg may be carried out with three animals (see Annex 2). If test substance-related mortality is produced, further testing at the next lower level may need to be carried out.

## 1.6 **OBSERVATIONS**

Animals are observed individually after dosing at least once during the first 30 minutes, periodically during the first 24 hours, with special attention given during the first 4 hours, and daily thereafter, for a total of 14 days, except where they need to be removed from the study and humanely killed for animal welfare reasons or are found dead. However, the duration of observation should not be fixed rigidly. It should be determined by the toxic reactions, time of onset and length of recovery period, and may thus be extended when considered necessary. The times at which signs of toxicity appear and disappear are important, especially if there is a tendency for toxic signs to be delayed (12). All observations are systematically recorded with individual records being maintained for each animal.

Additional observations will be necessary if the animals continue to display signs of toxicity. Observations should include changes in skin and fur, eyes and mucous membranes, and also respiratory, circulatory, autonomic and central nervous systems, and somatomotor activity and behaviour pattern. Attention should be directed to observations of tremors, convulsions, salivation, diarrhoea, lethargy, sleep and coma. The principles and criteria summarised in the Humane Endpoints Guidance Document (9) should be taken into consideration. Animals found in a moribund condition and animals showing severe pain or enduring signs of severe distress should be humanely killed. When animals are killed for humane reasons or found dead, the time of death should be recorded as precisely as possible.

### 1.6.1 **Body weight**

Individual weights of animals should be determined shortly before the test substance is administered, and at least weekly thereafter. Weight changes should be calculated and recorded. At the end of the test surviving animals are weighed and humanely killed.

### 1.6.2 **Pathology**

All test animals (including those that die during the test or are removed from the study for animal welfare reasons) should be subjected to gross necropsy. All gross pathological changes should be recorded for each animal. Microscopic examination of organs showing evidence of gross pathology in animals surviving 24 or more hours may also be considered because it may yield useful information.

2. **DATA**

Individual animal data should be provided. Additionally, all data should be summarised in tabular form, showing for each test group the number of animals used, the number of animals displaying signs of toxicity, the number of animals found dead during the test or killed for humane reasons, time of death of individual animals, a description and the time course of toxic effects and reversibility, and necropsy findings.

3. **REPORTING**

3.1 **Test report**

The test report must include the following information, as appropriate:

Test substance:

- physical nature, purity, and, where relevant, physico-chemical properties (including isomerisation);
- identification data, including CAS number.

Vehicle (if appropriate)

- justification for choice of vehicle, if other than water.

Test animals:

- species/strain used;
- microbiological status of the animals, when known;
- number, age, and sex of animals (including, where appropriate, a rationale for the use of males instead of females);
- source, housing conditions, diet etc.;

Test conditions:

- details of test substance formulation including details of the physical form of the material administered;
- details of the administration of the test substance including dosing volumes and time of dosing;
- details of food and water quality (including diet type/source, water source);
- the rationale for the selection of the starting dose.

Results:

- tabulation of response data and dose level for each animal (i.e. animals showing signs of toxicity including mortality; nature, severity, and duration of effects);
- tabulation of body weight and body weight changes;
- individual weights of animals at the day of dosing, in weekly intervals thereafter, and at the time of death or sacrifice
- date and time of death if prior to scheduled sacrifice
- time course of onset of signs of toxicity, and whether these were reversible for each animal;
- necropsy findings and histopathological findings for each animal, if available.

Discussion and interpretation of results.

Conclusions.

4.

**REFERENCES**

- (1) Roll R., Höfer-Bosse Th. And Kayser D. (1986). New Perspectives in Acute Toxicity Testing of Chemicals. *Toxicol. Lett.*, Suppl. 31, 86
- (2) Roll R., Riebschläger M., Mischke U. and Kayser D. (1989). Neue Wege zur Bestimmung der akuten Toxizität von Chemikalien. *Bundesgesundheitsblatt* 32, 336-341.
- (3) Diener W., Sichha L., Mischke U., Kayser D. and Schlede E. (1994). The Biometric Evaluation of the Acute-Toxic-Class Method (Oral). *Arch. Toxicol.* 68, 559-610
- (4) Diener W., Mischke U., Kayser D. and Schlede E. (1995). The Biometric Evaluation of the OECD Modified Version of the Acute-Toxic-Class Method (Oral). *Arch. Toxicol.* 69, 729-734.
- (5) Diener W., and Schlede E. (1999) Acute Toxicity Class Methods: Alterations to LD/LC<sub>50</sub> Tests. *ALTEX* 16, 129-134
- (6) Schlede E., Mischke U., Roll R. and Kayser D. (1992). A National Validation Study of the Acute-Toxic-Class Method – An Alternative to the LD<sub>50</sub> Test. *Arch. Toxicol.* 66, 455-470.
- (7) Schlede E., Mischke U., Diener W. and Kayser D. (1994). The International Validation Study of the Acute-Toxic-Class Method (Oral). *Arch. Toxicol.* 69, 659-670.
- (8) OECD (2001) Guidance Document on Acute Oral Toxicity Testing. Environmental Health and Safety Monograph Series on Testing and Assessment N. 24. Paris.
- (9) OECD (2000) Guidance Document on the Recognition, Assessment and Use of Clinical Signs as Humane Endpoints for Experimental Animals Used in Safety Evaluation. Environmental Health and Safety Monograph Series on Testing and Assessment N 19.
- (10) OECD (1998) Harmonized Integrated Hazard Classification System For Human Health And Environmental Effects Of Chemical Substances as endorsed by the 28<sup>th</sup> Joint Meeting of the Chemicals Committee and the Working Party on Chemicals in November 1998, Part 2, p. 11 [<http://webnet1.oecd.org/oecd/pages/home/displaygeneral/0,3380,EN-documents-521-14-no-24-no-0,FF.html>]
- (11) Lipnick R L, Cotruvo, J A, Hill R N, Bruce R D, Stitzel K A, Walker A P, Chu I; Goddard M, Segal L, Springer J A and Myers R C (1995) Comparison of the Up-and Down, Conventional LD<sub>50</sub>, and Fixed Dose Acute Toxicity Procedures. *Fd. Chem. Toxicol* 33, 223-231.
- (12) Chan P.K. and A.W. Hayes. (1994 ). Chap. 16. Acute Toxicity and Eye Irritancy. *Principles and Methods of Toxicology*. Third Edition. A.W. Hayes, Editor. Raven Press, Ltd., New York, USA.'



## ANNEX 1

**PROCEDURE TO BE FOLLOWED FOR EACH OF THE STARTING DOSES***GENERAL REMARKS*

For each starting dose, the respective testing schemes as included in this Annex outline the procedure to be followed.

- Annex 1 a: Starting dose is 5 mg/kg bw
- Annex 1 b: Starting dose is 50 mg/kg bw
- Annex 1 c: Starting dose is: 300 mg/kg bw
- Annex 1 d: Starting dose is: 2 000 mg/kg bw

Depending on the number of humanely killed or dead animals, the test procedure follows the indicated arrows.

ANNEX 1 A

TEST PROCEDURE WITH A STARTING DOSE OF 5 MG/KG BODY WEIGHT

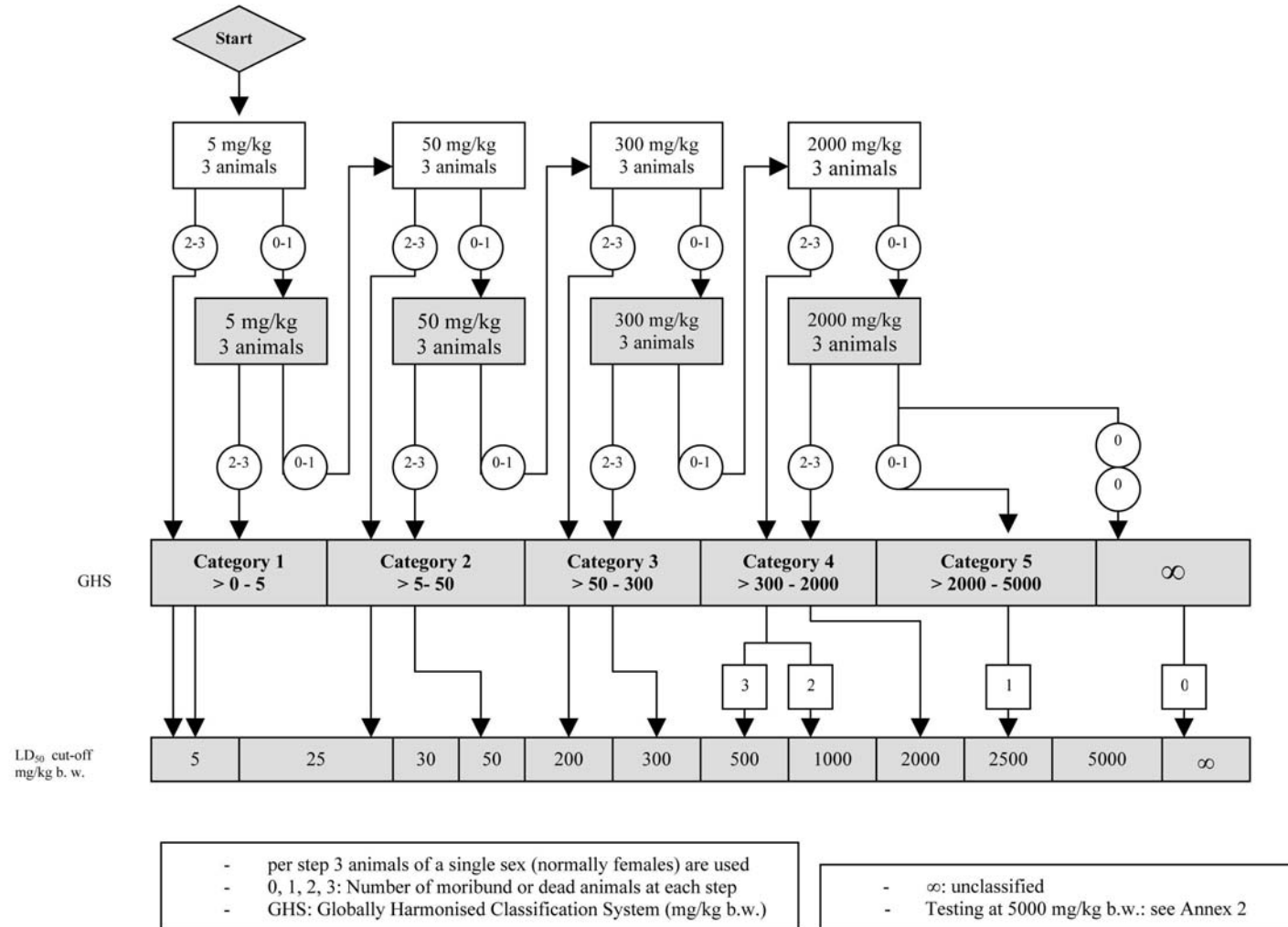

TEST PROCEDURE WITH A STARTING DOSE OF 50 MG/KG BODY WEIGHT

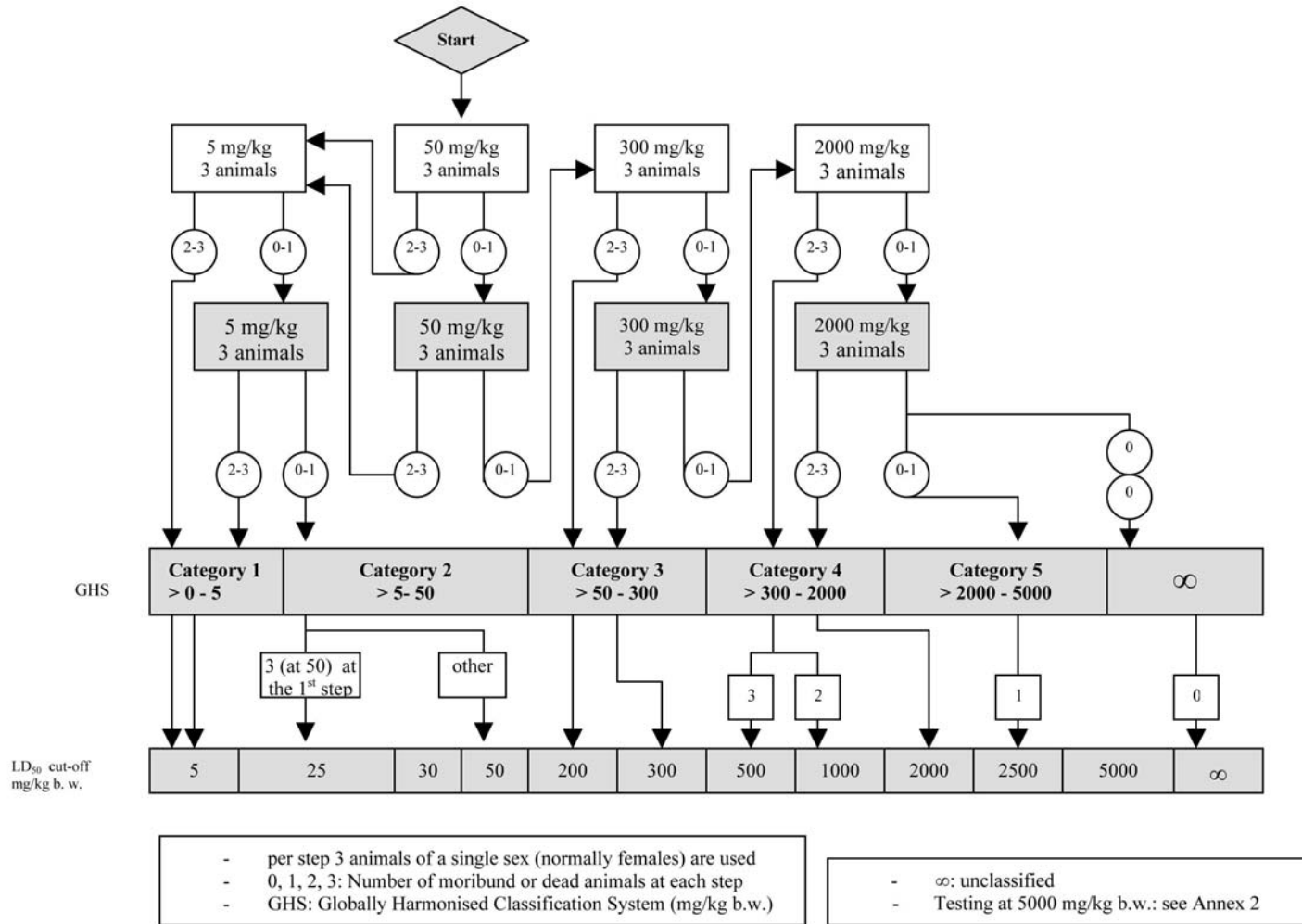

ANNEX 1C

TEST PROCEDURE WITH A STARTING DOSE OF 300 MG/KG BODY WEIGHT

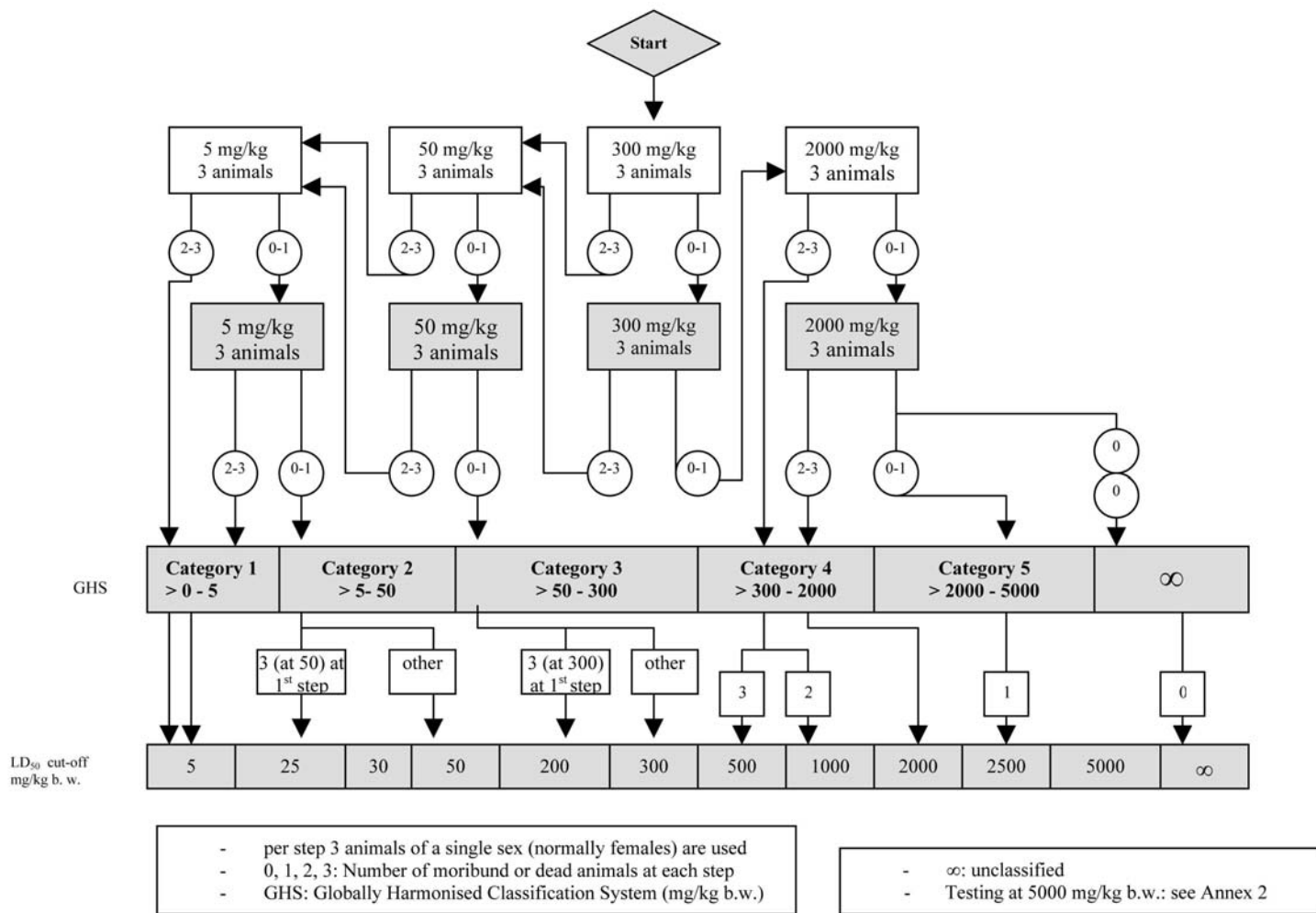

ANNEX 1 D

TEST PROCEDURE WITH A STARTING DOSE OF 2 000 MG/KG BODY WEIGHT

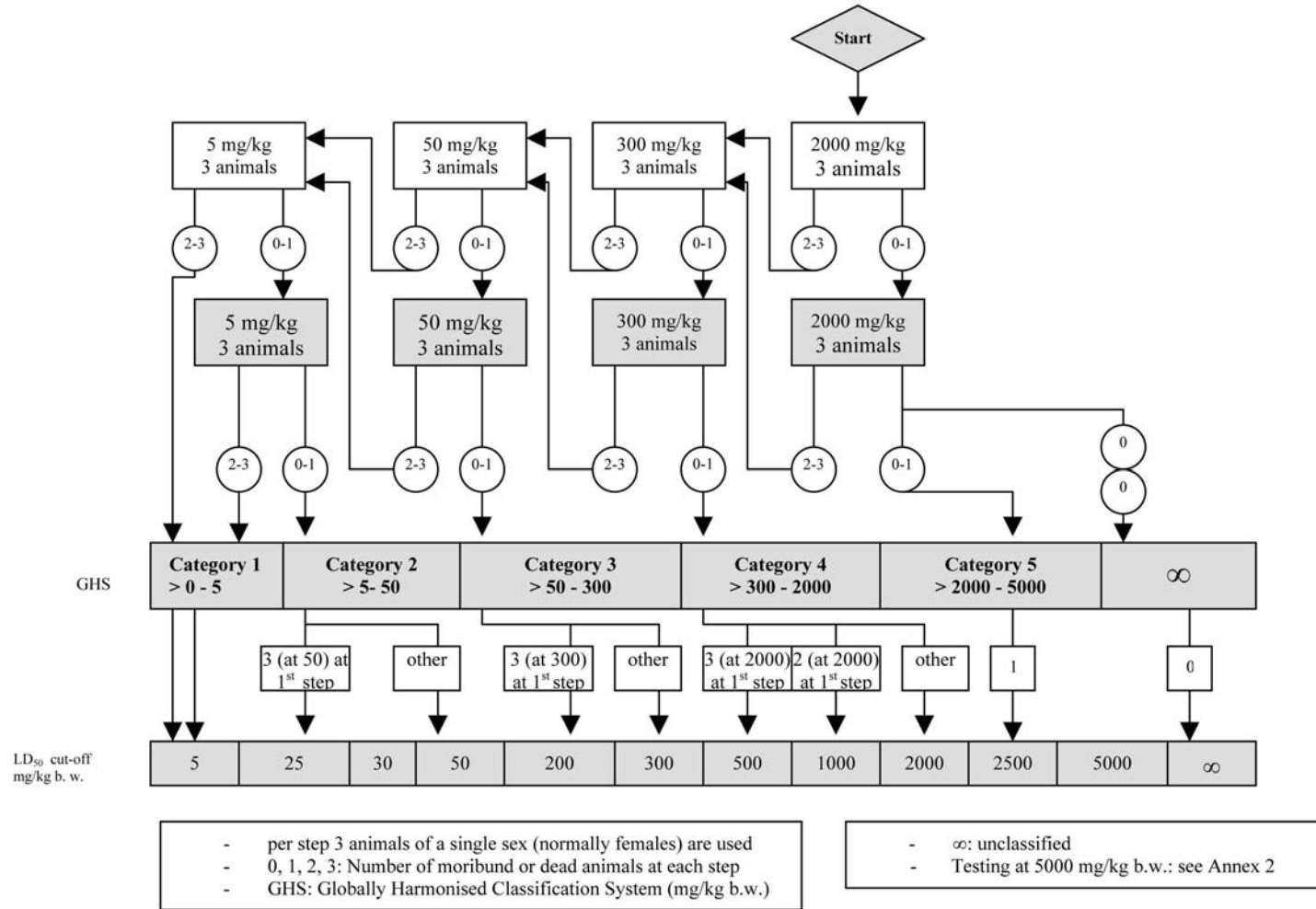

## ANNEX 2

**CRITERIA FOR CLASSIFICATION OF TEST SUBSTANCES WITH EXPECTED LD<sub>50</sub> VALUES EXCEEDING 2 000 MG/KG WITHOUT THE NEED FOR TESTING**

Criteria for hazard Category 5 are intended to enable the identification of test substances which are of relatively low acute toxicity hazard but which, under certain circumstances may present a danger to vulnerable populations. These substances are anticipated to have an oral or dermal LD<sub>50</sub> in the range of 2 000-5 000 mg/kg or equivalent doses for other routes. The test substance should be classified in the hazard category defined by: 2 000 mg/kg < LD<sub>50</sub> < 5 000 mg/kg (Category 5 in the GHS) in the following cases:

- a) If directed to this category by any of the testing schemes of Annex 1a-1d, based on mortality incidences;
- b) if reliable evidence is already available that indicates the LD<sub>50</sub> to be in the range of Category 5 values; or other animal studies or toxic effects in humans indicate a concern for human health of an acute nature.
- c) through extrapolation, estimation or measurement of data if assignment to a more hazardous class is not warranted, and
  - reliable information is available indicating significant toxic effects in humans, or
  - any mortality is observed when tested up to Category 4 values by the oral route, or
  - where expert judgement confirms significant clinical signs of toxicity, when tested up to Category 4 values, except for diarrhoea, piloerection or an ungroomed appearance, or
  - where expert judgement confirms reliable information indicating the potential for significant acute effects from the other animal studies.

**TESTING AT DOSES ABOVE 2 000 MG/KG**

Recognising the need to protect animal welfare, testing of animals in Category 5 (5 000 mg/kg) ranges is discouraged and should only be considered when there is a strong likelihood that results of such a test have a direct relevance for protecting human or animal health (10). No further testing should be conducted at higher dose levels.

When testing is required a dose of 5 000 mg/kg, only one step (i.e. three animals) is required. If the first animal dosed dies, then dosing proceeds at 2 000 mg/kg in accordance with the flow charts in Annex 1. If the first animal survives, two further animals are dosed. If only one of the three animals dies, the LD<sub>50</sub> value is expected to exceed 5 000 mg/kg. If both animals die, then dosing proceeds at 2 000 mg/kg.

ANNEX 3

**TEST METHOD B.1 tris: Guidance on classification according to EU scheme to cover the transition period until full implementation of the Globally Harmonised Classification System (GHS) (taken from reference (8))**

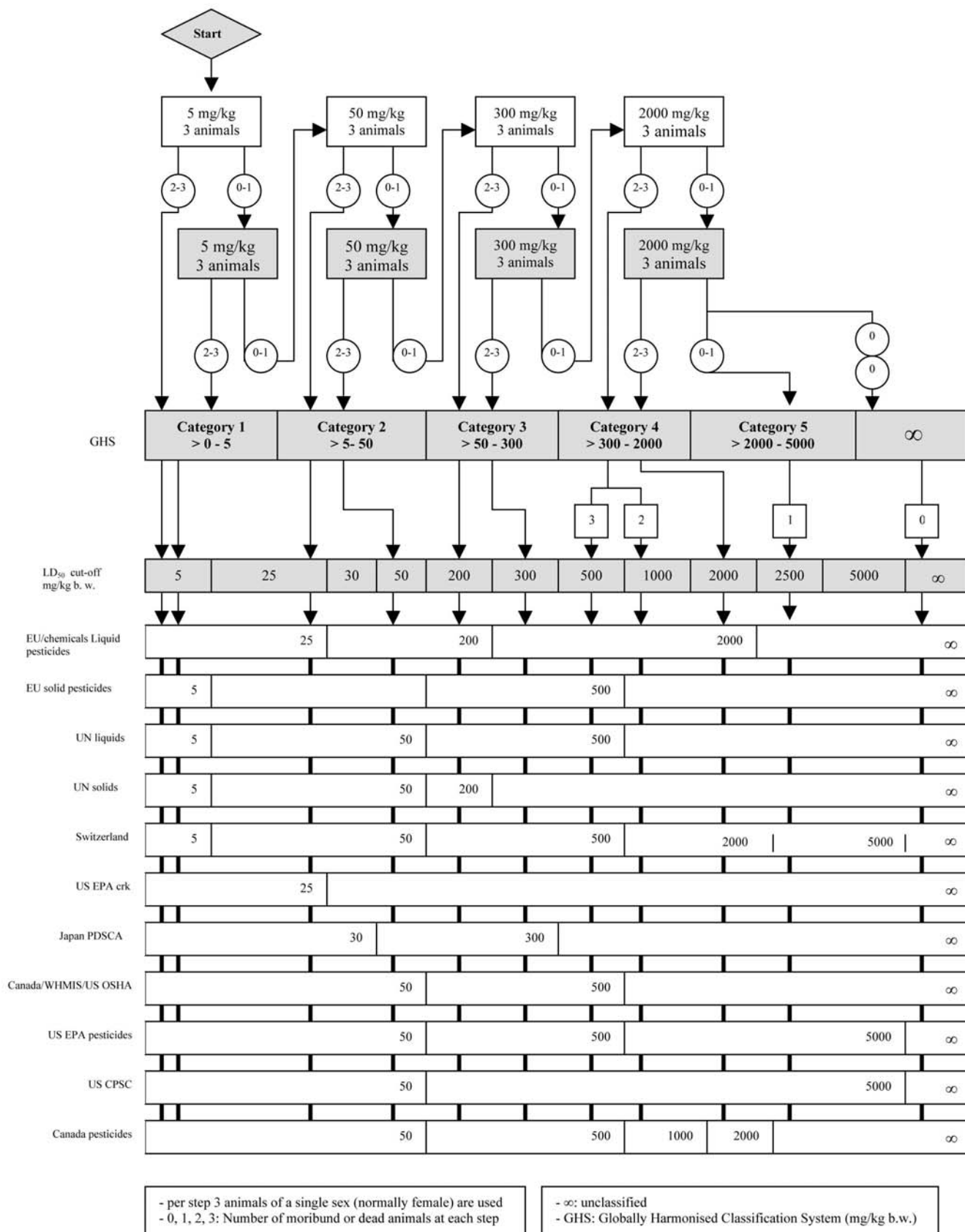

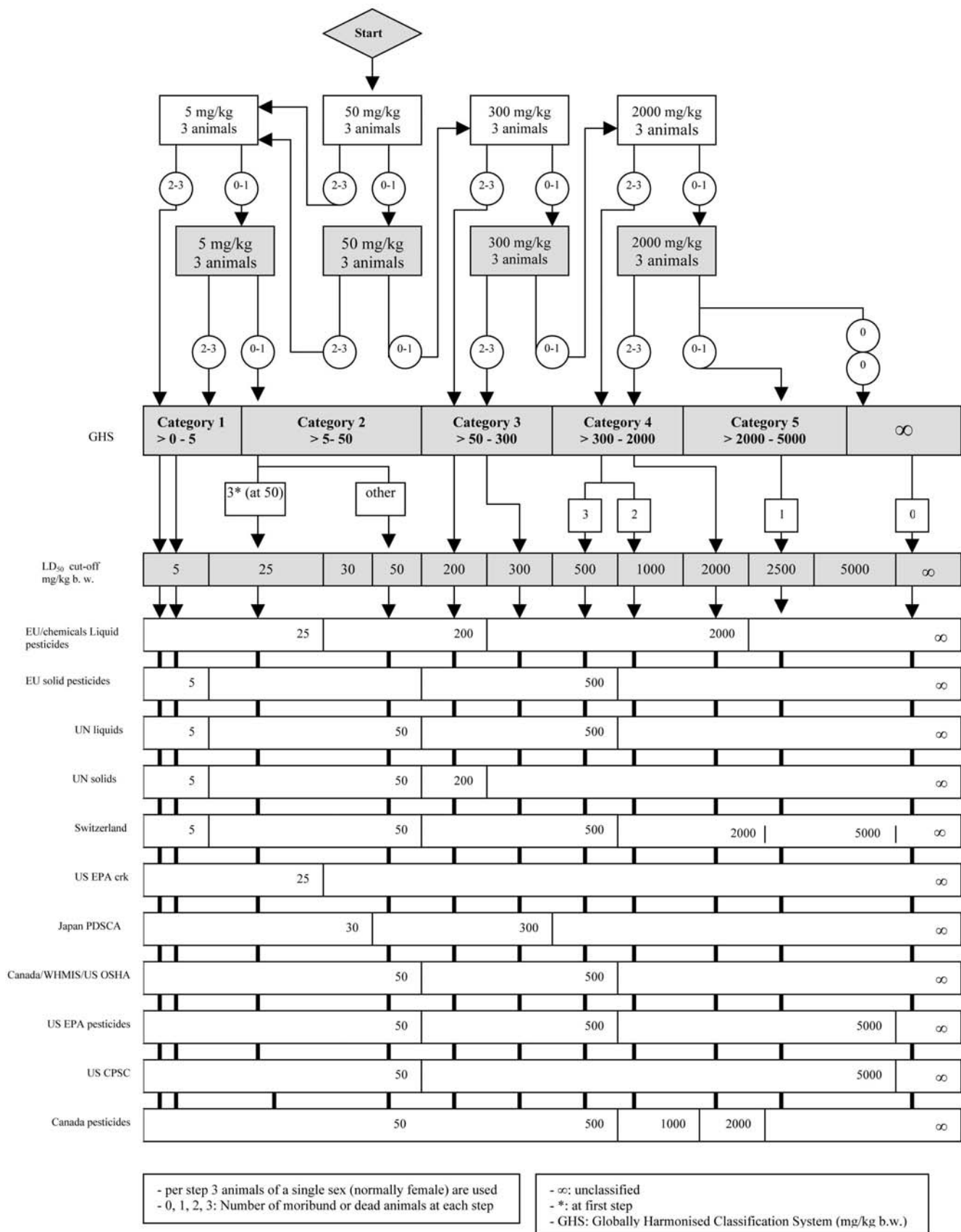



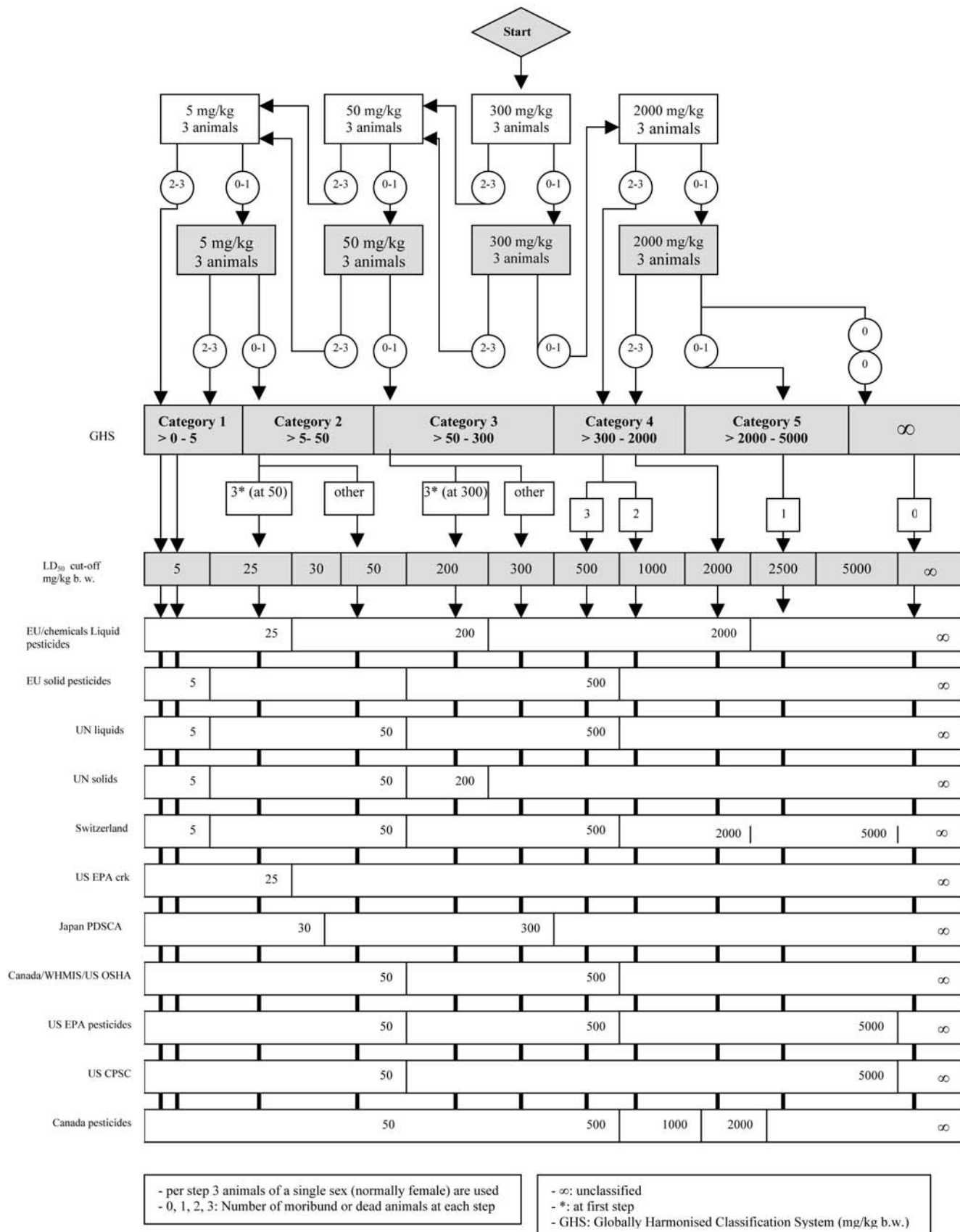

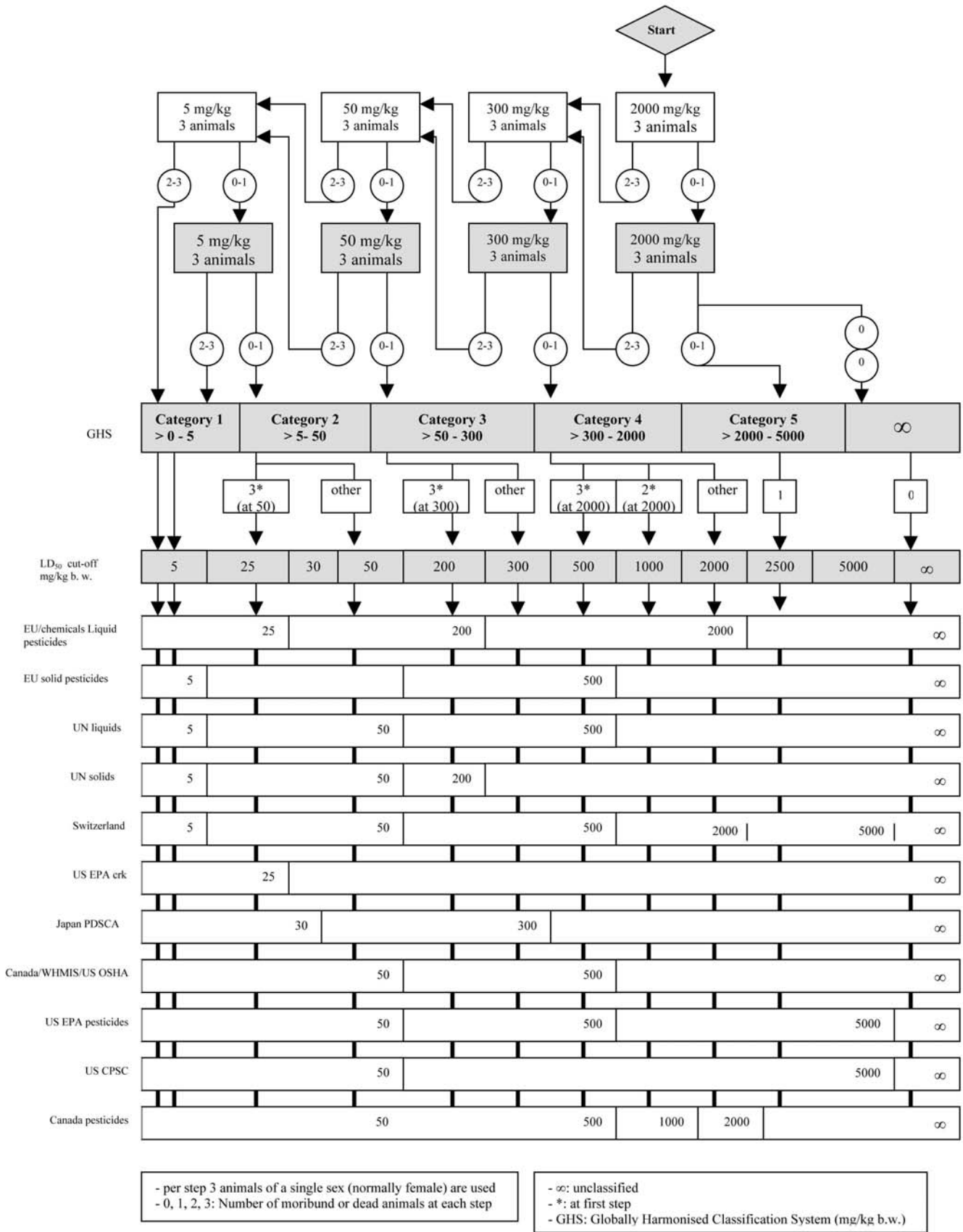

## ANNEX 2D

## B. 4. ACUTE TOXICITY: DERMAL IRRITATION/CORROSION

## 1. METHOD

This method is equivalent to the OECD TG 404 (2002).

## 1.1 INTRODUCTION

In the preparation of this updated method special attention was given to possible improvements in relation to animal welfare concerns and to the evaluation of all existing information on the test substance in order to avoid unnecessary testing in laboratory animals. This method includes the recommendation that prior to undertaking the described *in vivo* test for corrosion/irritation of the substance, a weight-of-the-evidence analysis be performed on the existing relevant data. Where insufficient data are available, they can be developed through application of sequential testing (1). The testing strategy includes the performance of validated and accepted *in vitro* tests and is provided as an Annex to this method. In addition, where appropriate, the successive, instead of simultaneous, application of the three test patches to the animal in the initial *in vivo* test is recommended.

In the interest of both sound science and animal welfare, *in vivo* testing should not be undertaken until all available data relevant to the potential dermal corrosivity/irritation of the substance have been evaluated in a weight-of-the-evidence analysis. Such data will include evidence from existing studies in humans and/or laboratory animals, evidence of corrosivity/irritation of one or more structurally related substances or mixtures of such substances, data demonstrating strong acidity or alkalinity of the substance (2)(3), and results from validated and accepted *in vitro* or *ex vivo* tests (4)(5)(5a). This analysis should decrease the need for *in vivo* testing for dermal corrosivity/irritation of substances for which sufficient evidence already exists from other studies as to those two endpoints.

A preferred sequential testing strategy, which includes the performance of validated and accepted *in vitro* or *ex vivo* tests for corrosion/irritation, is included as an Annex to this Method. The strategy was developed at, and unanimously recommended by the participants of, an OECD workshop (6), and has been adopted as the recommended testing strategy in the Globally Harmonised System for the Classification of Chemical Substances (GHS) (7). It is recommended that this testing strategy be followed prior to undertaking *in vivo* testing. For new substances it is the recommended stepwise testing approach for developing scientifically sound data on the corrosivity/irritation of the substance. For existing substances with insufficient data on dermal corrosion/irritation, the strategy should be used to fill missing data gaps. The use of a different testing strategy or procedure, or a decision not to use a stepwise testing approach, should be justified.

If a determination of corrosivity or irritation cannot be made using a weight-of-the-evidence analysis, consistent with the sequential testing strategy, an *in vivo* test should be considered (see Annex).

## 1.2 DEFINITIONS

**Dermal irritation:** is the production of reversible damage of the skin following the application of a test substance for up to 4 hours.

**Dermal corrosion:** is the production of irreversible damage of the skin; namely, visible necrosis through the epidermis and into the dermis, following the application of a test substance for up to four hours. Corrosive reactions are typified by ulcers, bleeding, bloody scabs, and, by the end of observation at 14 days, by discoloration due to blanching of the skin, complete areas of alopecia, and scars. Histopathology should be considered to evaluate questionable lesions.

## 1.3 PRINCIPLE OF THE TEST METHOD

The substance to be tested is applied in a single dose to the skin of an experimental animal; untreated skin areas of the test animal serve as the control. The degree of irritation/corrosion is read and scored at specified intervals and is further described in order to provide a complete evaluation of the effects. The duration of the study should be sufficient to evaluate the reversibility or irreversibility of the effects observed.

Animals showing continuing signs of severe distress and/or pain at any stage of the test should be humanely killed, and the substance assessed accordingly. Criteria for making the decision to humanely kill moribund and severely suffering animals can be found in reference (8).

#### 1.4 DESCRIPTION OF THE TEST METHOD

##### 1.4.1 **Preparation for the *in vivo* test**

###### 1.4.1.1 *Selection of animal species*

The albino rabbit is the preferable laboratory animal, and healthy young adult rabbits are used. A rationale for using other species should be provided.

###### 1.4.1.2 *Preparation of the animals*

Approximately 24 hours before the test, fur should be removed by closely clipping the dorsal area of the trunk of the animals. Care should be taken to avoid abrading the skin, and only animals with healthy, intact skin should be used.

Some strains of rabbit have dense patches of hair that are more prominent at certain times of the year. Such areas of dense hair growth should not be used as test sites.

###### 1.4.1.3 *Housing and feeding conditions*

Animals should be individually housed. The temperature of the experimental animal room should be 20°C ( $\pm$  3°C) for rabbits. Although the relative humidity should be at least 30 % and preferably not exceed 70 %, other than during room cleaning, the aim should be 50-60 %. Lighting should be artificial, the sequence being 12 hours light, 12 hours dark. For feeding, conventional laboratory diets may be used with an unrestricted supply of drinking water.

##### 1.4.2 **Test procedure**

###### 1.4.2.1 *Application of the test substance*

The test substance should be applied to a small area (approximately 6 cm<sup>2</sup>) of skin and covered with a gauze patch, which is held in place with non-irritating tape. In cases in which direct application is not possible (e.g., liquids or some pastes), the test substance should first be applied to the gauze patch, which is then applied to the skin. The patch should be loosely held in contact with the skin by means of a suitable semi-occlusive dressing for the duration of the exposure period. If the test substance is applied to the patch, it should be attached to the skin in such a manner that there is good contact and uniform distribution of the substance on the skin. Access by the animal to the patch and ingestion or inhalation of the test substance should be prevented.

Liquid test substances are generally used undiluted. When testing solids (which may be pulverised, if considered necessary), the test substance should be moistened with the smallest amount of water (or, where necessary, of another suitable vehicle) sufficient to ensure good skin contact. When vehicles other than water are used, the potential influence of the vehicle on irritation of the skin by the test substance should be minimal, if any.

At the end of the exposure period, which is normally 4 hours, residual test substance should be removed, where practicable, using water or an appropriate solvent without altering the existing response or the integrity of the epidermis.

###### 1.4.2.2 *Dose level*

A dose of 0.5 ml. of liquid or 0.5 g of solid or paste is applied to the test site.

###### 1.4.2.3 *Initial test (In vivo dermal irritation/corrosion test using one animal)*

It is strongly recommended that the *in vivo* test be performed initially using one animal, especially when the substance is suspected to have corrosion potential. This is in accordance with the sequential testing strategy (see Annex 1).

When a substance has been judged to be corrosive on the basis of a weight-of-the-evidence analysis, no further animal testing is needed. For most substances suspected of being corrosive, further *in vivo* testing is normally not necessary. However, in those cases where additional data are felt warranted because of insufficient evidence, limited animal testing may be carried out using the following approach: Up to three tests patches are applied sequentially to the animal. The first patch is removed after three minutes. If no serious skin reaction is observed, a second patch is applied and removed after one hour. If the observations at this stage indicate that exposure can humanely be allowed to extend to four hours, a third patch is applied and removed after four hours, and the response is graded.

If a corrosive effect is observed after any of the three sequential exposures, the test is immediately terminated. If a corrosive effect is not observed after the last patch is removed, the animal is observed for 14 days, unless corrosion develops at an earlier time point.

In those cases in which the test substance is not expected to produce corrosion but may be irritating, a single patch should be applied to one animal for four hours.

#### 1.4.2.4 *Confirmatory test (In vivo dermal irritation test with additional animals)*

If a corrosive effect is not observed in the initial test, the irritant or negative response should be confirmed using up to two additional animals, each with one patch, for an exposure period of four hours. If an irritant effect is observed in the initial test, the confirmatory test may be conducted in a sequential manner, or by exposing two additional animals simultaneously. In the exceptional case, in which the initial test is not conducted, two or three animals may be treated with a single patch, which is removed after four hours. When two animals are used, if both exhibit the same response, no further testing is needed. Otherwise, the third animal is also tested. Equivocal responses may need to be evaluated using additional animals.

#### 1.4.2.5 *Observation period*

The duration of the observation period should be sufficient to evaluate fully the reversibility of the effects observed. However, the experiment should be terminated at any time that the animal shows continuing signs of severe pain or distress. To determine the reversibility of effects, the animals should be observed up to 14 days after removal of the patches. If reversibility is seen before 14 days, the experiment should be terminated at that time.

#### 1.4.2.6 *Clinical observations and grading of skin reactions*

All animals should be examined for signs of erythema and oedema, and the responses scored at 60 minutes, and then at 24, 48 and 72 hours after patch removal. For the initial test in one animal, the test site is also examined immediately after the patch has been removed. Dermal reactions are graded and recorded according to the grades in the Table below. If there is damage to skin which cannot be identified as irritation or corrosion at 72 hours, observations may be needed until day 14 to determine the reversibility of the effects. In addition to the observation of irritation, all local toxic effects, such as defatting of the skin, and any systemic adverse effects (e.g., effects on clinical signs of toxicity and body weight), should be fully described and recorded. Histopathological examination should be considered to clarify equivocal responses.

The grading of skin responses is necessarily subjective. To promote harmonisation in grading of skin response and to assist testing laboratories and those involved in making and interpreting the observations, the personnel performing the observations need to be adequately trained in the scoring system used (see Table below). An illustrated guide for grading skin irritation and other lesions could be helpful (9).

## 2. **DATA**

### 2.1 PRESENTATION OF RESULTS

Study results should be summarised in tabular form in the final test report and should cover all items listed in section 3.1.

## 2.2 EVALUATION OF RESULTS

The dermal irritation scores should be evaluated in conjunction with the nature and severity of lesions, and their reversibility or lack of reversibility. The individual scores do not represent an absolute standard for the irritant properties of a material, as other effects of the test material are also evaluated. Instead, individual scores should be viewed as reference values, which need to be evaluated in combination with all other observations from the study.

Reversibility of dermal lesions should be considered in evaluating irritant responses. When responses such as alopecia (limited area), hyperkeratosis, hyperplasia and scaling, persist to the end of the 14-day observation period, the test substance should be considered an irritant.

## 3. REPORTING

### 3.1 TEST REPORT

The test report must include the following information:

Rationale for *in vivo* testing: weight-of-evidence analysis of pre-existing test data, including results from sequential testing strategy:

- description of relevant data available from prior testing;
- data derived at each stage of testing strategy;
- description of *in vitro* tests performed, including details of procedures, results obtained with test/reference substances;
- weight-of-the-evidence analysis for performing *in vivo* study

Test substance:

- identification data (e.g., CAS number; source; purity; known impurities; lot number);
- physical nature and physicochemical properties (e.g. pH, volatility, solubility, stability);
- if mixture, composition and relative percentages of components.

Vehicle:

- identification, concentration (where appropriate), volume used;
- justification for choice of vehicle.

Test animals:

- species/strain used, rationale for using animals other than albino rabbit;
- number of animals of each sex;
- individual animal weights at start and conclusion of test;
- age at start of study;
- source of animals, housing conditions, diet, etc.

Test conditions:

- technique of patch site preparation;
- details of patch materials used and patching technique;
- details of test substance preparation, application, and removal.

## Results:

- tabulation of irritation/corrosion response scores for each animal at all time points measured;
- descriptions of all lesions observed;
- narrative description of nature and degree of irritation or corrosion observed, and any histopathological findings;
- description of other adverse local (e.g., defatting of skin) and systemic effects in addition to dermal irritation or corrosion.

## Discussion of results

## 4. REFERENCES

- (1) Barratt, M.D., Castell, J.V., Chamberlain, M., Combes, R.D., Dearden, J.C., Fentem, J.H., Gerner, I., Giuliani, A., Gray, T.J.B., Livingston, D.J., Provan, W.M., Rutten, F.A.J.J.L., Verhaar, H.J.M., Zbinden, P. (1995) The Integrated Use of Alternative Approaches for Predicting Toxic Hazard. ECVAM Workshop Report 8. ATLA 23, 410-429.
- (2) Young, J.R., How, M.J., Walker, A.P., Worth W.M.H. (1988) Classification as Corrosive or Irritant to Skin of Preparations Containing Acidic or Alkaline Substance Without Testing on Animals. *Toxicol. In Vitro*, 2, 19-26.
- (3) Worth, A.P., Fentem, J.H., Balls, M., Botham, P.A., Curren, R.D., Earl, L.K., Esdaile, D.J., Liebsch, M. (1998) Evaluation of the proposed OECD Testing Strategy for skin corrosion. ATLA 26, 709-720.
- (4) ECETOC (1990) Monograph No. 15, "Skin Irritation", European Chemical Industry, Ecology and Toxicology Centre, Brussels.
- (5) Fentem, J.H., Archer, G.E.B., Balls, M., Botham, P.A., Curren, R.D., Earl, L.K., Esdaile, D.J., Holzhutter, H.G. and Liebsch, M. (1998) The ECVAM international validation study on in vitro tests for skin corrosivity. 2. Results and evaluation by the Management Team. *Toxicology in Vitro* 12, pp. 483-524.
- (5a) Testing Method B.40 Skin Corrosion.
- (6) OECD (1996) OECD Test Guidelines Programme: Final Report of the OECD Workshop on Harmonization of Validation and Acceptance Criteria for Alternative Toxicological Test Methods. Held in Solna, Sweden, 22 - 24 January 1996 (<http://www1.oecd.org/ehs/test/background.htm>).
- (7) OECD (1998) Harmonized Integrated Hazard Classification System for Human Health and Environmental Effects of Chemical Substances, as endorsed by the 28th Joint Meeting of the Chemicals Committee and the Working Party on Chemicals, November 1998 (<http://www1.oecd.org/ehs/Class/HCL6.htm>).
- (8) OECD (2000). Guidance Document on the Recognition, Assessment and Use of Clinical Signs as Humane Endpoints for Experimental Animals Used in Safety Evaluation. OECD Environmental Health and Safety Publications. Series on Testing and Assessment No. 19 (<http://www1.oecd.org/ehs/test/monos.htm>).
- (9) EPA (1990). Atlas of Dermal Lesions, (20T-2004). United States Environmental Protection Agency, Office of Pesticides and Toxic Substances, Washington, DC, August 1990. [Available from OECD Secretariat upon request].

TABLE I: GRADING OF SKIN REACTIONS

**Erythema and Eschar Formation**

|   |   |
|---|---|
| No erythema .....   | 0 |
| Very slight erythema (barely perceptible) .....   | 1 |
| Well defined erythema .....   | 2 |
| Moderate to severe erythema .....   | 3 |
| Severe erythema (beef redness) to eschar formation preventing grading of erythema ..... | 4 |

Maximum possible: 4

**Oedema Formation**

|   |   |
|---|---|
| No oedema .....   | 0 |
| Very slight oedema (barely perceptible) .....                                     | 1 |
| Slight oedema (edges of area well defined by definite raising) .....              | 2 |
| Moderate oedema (raised approximately 1 mm) .....                                 | 3 |
| Severe oedema (raised more than 1 mm and extending beyond area of exposure) ..... | 4 |

Maximum possible: 4

Histopathological examination may be carried out to clarify equivocal responses.



## ANNEX

**A Sequential Testing Strategy for Dermal Irritation and Corrosion****GENERAL CONSIDERATIONS**

In the interest of sound science and animal welfare, it is important to avoid the unnecessary use of animals and to minimise any testing that is likely to produce severe responses in animals. All information on a substance relevant to its potential skin corrosivity/irritancy should be evaluated prior to considering *in vivo* testing. Sufficient evidence may already exist to classify a test substance as to its dermal corrosion or irritation potential without the need to conduct testing in laboratory animals. Therefore, utilising a weight-of-the-evidence analysis and a sequential testing strategy, will minimise the need for *in vivo* testing, especially if the substance is likely to produce severe reactions.

It is recommended that a weight-of-the-evidence analysis be used to evaluate existing information regarding the skin irritation and corrosion of substances to determine whether additional studies, other than *in vivo* dermal studies, should be performed to help characterise such potential. Where further studies are needed, it is recommended that the sequential testing strategy be utilised to develop the relevant experimental data. For substances which have no testing history, the sequential testing strategy should be utilised to develop the data set needed to evaluate its dermal corrosion/irritation potential. The testing strategy described in this Annex was developed at an OECD workshop (1) and was later affirmed and expanded in the Harmonised Integrated Hazard Classification System for Human Health and Environmental Effects of Chemical Substances, as endorsed by the 28th Joint Meeting of the Chemicals Committee and the Working Party on Chemicals, in November 1998 (2).

Although this sequential testing strategy is not an integral part of testing method B.4, it expresses the recommended approach for the determination of skin irritation/corrosion characteristics. This approach represents both best practice and an ethical benchmark for *in vivo* testing for skin irritation/corrosion. The testing method provides guidance for the conduct of the *in vivo* test and summarises the factors that should be addressed before initiating such a test. The strategy provides an approach for the evaluation of existing data on the skin irritation/corrosion properties of test substances and a tiered approach for the generation of relevant data on substances for which additional studies are needed, or for which no studies have been performed. It also recommends the performance of validated and accepted *in vitro* or *ex vivo* tests for skin corrosion/irritation under specific circumstances.

**DESCRIPTION OF THE EVALUATION AND TESTING STRATEGY**

Prior to undertaking tests as part of the sequential testing strategy (Figure), all available information should be evaluated to determine the need for *in vivo* skin testing. Although significant information might be gained from the evaluation of single parameters (e.g., extreme pH), the totality of existing information should be considered. All relevant data on the effects of the substance in question, or its analogues, should be evaluated in making a weight-of-the-evidence decision, and a rationale for the decision should be presented. Primary emphasis should be placed upon existing human and animal data on the substance, followed by the outcome of *in vitro* or *ex vivo* testing. *In vivo* studies of corrosive substances should be avoided whenever possible. The factors considered in the testing strategy include:

*Evaluation of existing human and animal data (Step 1).* Existing human data, e.g. clinical or occupational studies and case reports, and/or animal test data, e.g. from single or repeated dermal exposure toxicity studies, should be considered first, because they provide information directly related to effects on the skin. Substances with known irritancy or corrosivity, and those with clear evidence of non-corrosivity or non-irritancy, need not be tested in *in vivo* studies.

*Analysis of structure activity relationships (SAR) (Step 2).* The results of testing of structurally related substances should be considered, if available. When sufficient human and/or animal data are available on structurally related substances or mixtures of such substances to indicate their skin corrosion/irritancy potential, it can be presumed that the test substance being evaluated will produce the same responses. In those cases, the test substance may not need to be tested. Negative data from studies of structurally related substances or mixtures of such substances do not constitute sufficient evidence of non-corrosivity/non-irritancy of a substance under the sequential testing strategy. Validated and accepted SAR approaches should be used to identify both dermal corrosion and irritation potential.

*Physicochemical properties and chemical reactivity (Step 3).* Substances exhibiting pH extremes such as  $\leq 2.0$  and  $\geq 11.5$  may have strong local effects. If extreme pH is the basis for identifying a substance as corrosive to skin, then its acid/alkali reserve (or buffering capacity) may also be taken into consideration (3)(4). If the buffering capacity suggests that a substance may not be corrosive to the skin, then further testing should be undertaken to confirm this, preferably by the use of a validated and accepted *in vitro* or *ex vivo* test (see steps 5 and 6).

*Dermal toxicity (Step 4).* If a chemical has proven to be very toxic by the dermal route, an *in vivo* dermal irritation/corrosion study may not be practicable because the amount of test substance normally applied could exceed the very toxic dose and, consequently result in the death or severe suffering of the animals. In addition, when dermal toxicity

studies utilising albino rabbits have already been performed up to the limit dose level of 2 000 mg/kg body weight or higher, and no dermal irritation or corrosion has been seen, additional testing for skin irritation/corrosion may not be needed. A number of considerations should be borne in mind when evaluating acute dermal toxicity in previously performed studies. For example, reported information on dermal lesions may be incomplete. Testing and observations may have been made on a species other than the rabbit, and species may differ widely in sensitivity of their responses. Also the form of test substance applied to animals may not have been suitable for assessment of skin irritation/corrosion (e.g., dilution of substances for testing dermal toxicity (5)). However, in those cases in which well-designed and conducted dermal toxicity studies have been performed in rabbits, negative findings may be considered sufficient evidence that the substance is not corrosive or irritating.

*Results from in vitro or ex vivo tests (Steps 5 and 6).* Substances that have demonstrated corrosive or severe irritant properties in a validated and accepted *in vitro* or *ex vivo* test (6)(7) designed for the assessment of these specific effects, need not be tested in animals. It can be presumed that such substances will produce similar severe effects *in vivo*.

*In vivo test in rabbits (Steps 7 and 8).* Should a weight-of-the-evidence decision be made to conduct *in vivo* testing, it should begin with an initial test using one animal. If the results of this test indicate the substance to be corrosive to the skin, further testing should not be performed. If a corrosive effect is not observed in the initial test, the irritant or negative response should be confirmed using up to two additional animals for an exposure period of four hours. If an irritant effect is observed in the initial test, the confirmatory test may be conducted in a sequential manner, or by exposing the two additional animals simultaneously.

## REFERENCES

- (1) OECD (1996). Test Guidelines Programme: Final Report on the OECD Workshop on Harmonization of Validation and Acceptance Criteria for Alternative Toxicological Test Methods. Held on Solna, Sweden, 22 – 24 January 1996 (<http://www1.oecd.org/ehs/test/background.htm>).
- (2) OECD (1998). Harmonized Integrated Hazard Classification System for Human Health and Environmental Effects of Chemical Substances, as endorsed by the 28th Joint Meeting of the Chemicals Committee and the Working Party on Chemicals, November 1998 (<http://www1.oecd.org/ehs/Class/HCL6.htm>).
- (3) Worth, A.P., Fentem J.H., Balls M., Botham P.A., Curren R.D., Earl L.K., Esdail D.J., Liebsch M. (1998). An Evaluation of the Proposed OECD Testing Strategy for Skin Corrosion. *ATLA* 26, 709-720.
- (4) Young, J.R., How, M.J., Walker, A.P., Worth, W.M.H. (1988). Classification as Corrosive or Irritant to Skin of Preparations Containing Acidic or Alkaline Substances, Without Testing on Animals. *Toxic In Vitro*, 2 (1) pp 19-26.
- (5) Patil, S.M., Patrick, E., Maibach, H.I. (1996) Animal, Human, and In Vitro Test Methods for Predicting Skin Irritation, in: Francis N. Marzulli and Howard I. Maibach (editors): *Dermatotoxicology*. Fifth Edition ISBN 1-56032-356-6, Chapter 31, 411-436.
- (6) Testing Method B.40.
- (7) Fentem, J.H., Archer, G.E.B., Balls, M., Botham, P.A., Curren, R.D., Earl, L.K., Esdail, D.J., Holzhutter, H.G. and Liebsch, M. (1998) The ECVAM international validation study on in vitro tests for skin corrosivity. 2. Results and evaluation by the Management Team. *Toxicology in Vitro* 12, pp. 483–524.

FIGURE

## TESTING AND EVALUATION STRATEGY FOR DERMAL IRRITATION /CORROSION

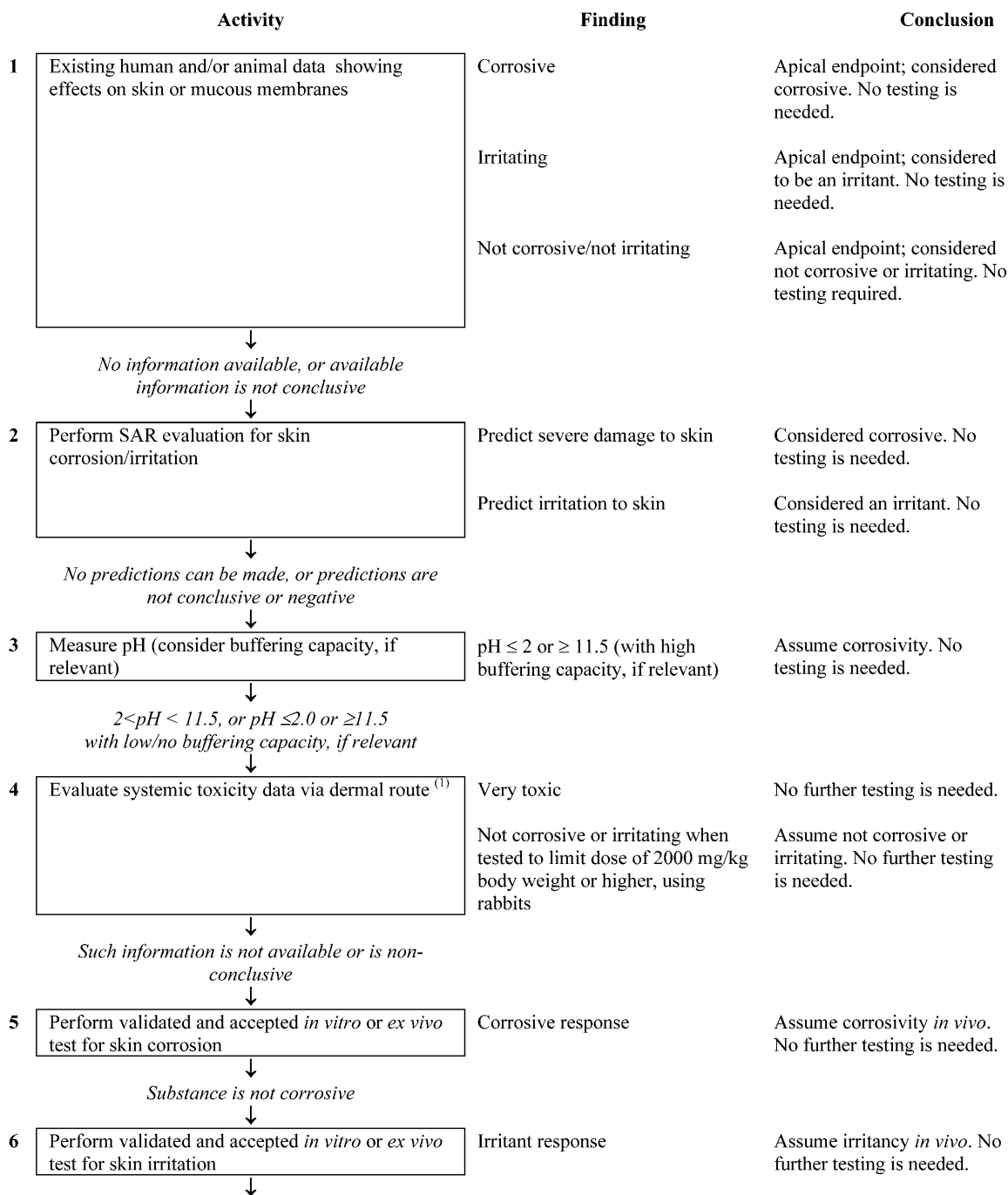

<sup>(1)</sup> can be considered before Steps 2 and 3.

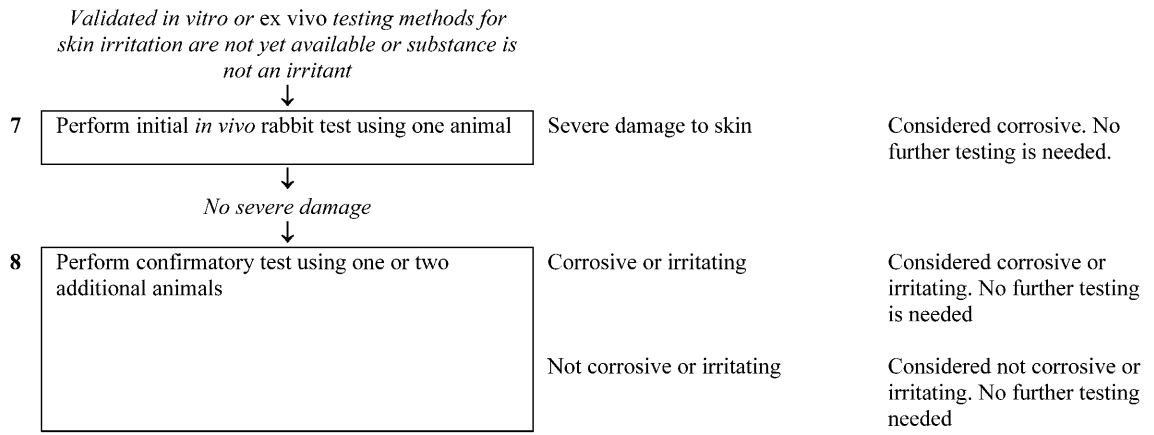

## ANNEX 2E

## B. 5. ACUTE TOXICITY: EYE IRRITATION/CORROSION

## 1. METHOD

This method is equivalent to the OECD TG 405 (2002)

## 1.1 INTRODUCTION

In the preparation of this updated method special attention was given to possible improvements through the evaluation of all existing information on the test substance in order to avoid unnecessary testing in laboratory animals and thereby address animal welfare concerns. This method includes the recommendation that prior to undertaking the described *in vivo* test for acute eye irritation/corrosion, a weight-of-the-evidence analysis be performed (1) on the existing relevant data. Where insufficient data are available, it is recommended that they be developed through application of sequential testing (2)(3). The testing strategy includes the performance of validated and accepted *in vitro* tests and is provided as an Annex to the testing method. In addition, the use of an *in vivo* dermal irritation/corrosion test to predict eye corrosion prior to consideration of an *in vivo* eye test is recommended.

In the interest of both sound science and animal welfare, *in vivo* testing should not be considered until all available data relevant to the potential eye corrosivity/irritation of the substance has been evaluated in a weight-of-the-evidence analysis. Such data will include evidence from existing studies in humans and/or laboratory animals, evidence of corrosivity/irritation of one or more structurally related substances or mixtures of such substances, data demonstrating high acidity or alkalinity of the substance (4)(5), and results from validated and accepted *in vitro* or *ex vivo* tests for skin corrosion and irritation (6)(6a). The studies may have been conducted prior to, or as a result of, a weight-of-the-evidence analysis.

For certain substances, such an analysis may indicate the need for *in vivo* studies of the ocular corrosion/irritation potential of the substance. In all such cases, before considering the use of the *in vivo* eye test, preferably a study of the *in vivo* dermal effects of the substance should be conducted first and evaluated in accordance with testing method B.4 (7). The application of a weight-of-the-evidence analysis and the sequential testing strategy should decrease the need for *in vivo* testing for eye corrosivity/irritation of substances for which sufficient evidence already exists from other studies. If a determination of eye corrosion or irritation potential cannot be made using the sequential testing strategy, even after the performance of an *in vivo* study of dermal corrosion and irritation, an *in vivo* eye corrosion/irritation test may be performed.

A preferred sequential testing strategy, which includes the performance of validated *in vitro* or *ex vivo* tests for corrosion/irritation, is included in the Annex to this testing method. The strategy was developed at, and unanimously recommended by the participants of, an OECD workshop (8), and has been adopted as the recommended testing strategy in the Globally Harmonised System for the Classification of Chemical Substances (GHS) (9). It is recommended that this testing strategy be followed prior to undertaking *in vivo* testing. For new substances it is the recommended stepwise testing approach for developing scientifically sound data on the corrosivity/irritation of the substance. For existing substances with insufficient data on skin and eye corrosion/irritation, the strategy should be used to fill missing data gaps. The use of a different testing strategy or procedure, or the decision not to use a stepwise testing approach, should be justified.

## 1.2 DEFINITIONS

**Eye irritation:** is the production of changes in the eye following the application of a test substance to the anterior surface of the eye, which are fully reversible within 21 days of application.

**Eye corrosion:** is the production of tissue damage in the eye, or serious physical decay of vision, following application of a test substance to the anterior surface of the eye, which is not fully reversible within 21 days of application

### 1.3 PRINCIPLE OF THE TEST METHOD

The substance to be tested is applied in a single dose to one of the eyes of the experimental animal; the untreated eye serves as the control. The degree of eye irritation/corrosion is evaluated by scoring lesions of conjunctiva, cornea, and iris, at specific intervals. Other effects in the eye and adverse systemic effects are also described to provide a complete evaluation of the effects. The duration of the study should be sufficient to evaluate the reversibility or irreversibility of the effects.

Animals showing continuing signs of severe distress and/or pain at any stage of the test should be humanely killed, and the substance assessed accordingly. Criteria for making the decision to humanely kill moribund and severely suffering animals can be found in reference (10).

### 1.4 DESCRIPTION OF THE TEST METHOD

#### 1.4.1 Preparation for the *in vivo* test

##### 1.4.1.1 Selection of species

The albino rabbit is the preferable laboratory animal, and healthy young adult animals are used. A rationale for using other strains or species should be provided.

##### 1.4.1.2 Preparation of animals

Both eyes of each experimental animal provisionally selected for testing should be examined within 24 hours before testing starts. Animals showing eye irritation, ocular defects, or pre-existing corneal injury should not be used.

##### 1.4.1.3 Housing and feeding conditions

Animals should be individually housed. The temperature of the experimental animal room should be 20°C ( $\pm 3^\circ\text{C}$ ) for rabbits. Although the relative humidity should be at least 30 % and preferably not exceed 70 %, other than during room cleaning, the aim should be 50-60 %. Lighting should be artificial, the sequence being 12 hours light, 12 hours dark. For feeding, conventional laboratory diets may be used with an unrestricted supply of drinking water.

#### 1.4.2 Test procedure

##### 1.4.2.1 Application of the test substance

The test substance should be placed in the conjunctival sac of one eye of each animal after gently pulling the lower lid away from the eyeball. The lids are then gently held together for about one second in order to prevent loss of the material. The other eye, which remains untreated, serves as a control.

##### 1.4.2.2 Irrigation

The eyes of the test animals should not be washed for at least 24 hours following instillation of the test substance, except for solids (see section 1.4.2.3.2), and in case of immediate corrosive or irritating effects. At 24 hours a washout may be used if considered appropriate.

Use of a satellite group of animals to investigate the influence of washing is not recommended unless it is scientifically justified. If a satellite group is needed, two rabbits should be used. Conditions of washing should be carefully documented, e.g., time of washing; composition and temperature of wash solution; duration, volume, and velocity of application.

##### 1.4.2.3 Dose level

##### 1.4.2.3.1 Testing of liquids

For testing liquids, a dose of 0.1 ml is used. Pump sprays should not be used for instilling the substance directly into the eye. The liquid spray should be expelled and collected in a container prior to instilling 0.1 ml into the eye.

#### 1.4.2.3.2 *Testing of solids*

When testing solids, pastes, and particulate substances, the amount used should have a volume of 0.1 ml or a weight of not more than 100 mg. The test material should be ground to a fine dust. The volume of solid material should be measured after gently compacting it, e.g., by tapping the measuring container. If the solid test substance has not been removed from the eye of the test animal by physiological mechanisms at the first observation time point of 1 hour after treatment, the eye may be rinsed with saline or distilled water.

#### 1.4.2.3.3 *Testing of aerosols*

It is recommended that all pump sprays and aerosols be collected prior to instillation into the eye. The one exception is for substances in pressurised aerosol containers, which cannot be collected due to vapourisation. In such cases, the eye should be held open, and the test substance administered to the eye in a simple burst of about one second, from a distance of 10 cm directly in front of the eye. This distance may vary depending on the pressure of the spray and its contents. Care should be taken not to damage the eye from the pressure of the spray. In appropriate cases, there may be a need to evaluate the potential for "mechanical" damage to the eye from the force of the spray.

An estimate of the dose from an aerosol can be made by simulating the test as follows: the substance is sprayed on to weighing paper through an opening the size of a rabbit eye placed directly before the paper. The weight increase of the paper is used to approximate the amount sprayed into the eye. For volatile substances, the dose may be estimated by weighing a receiving container before and after removal of the test material.

#### 1.4.2.4 *Initial test (In vivo eye irritation/corrosion test using one animal)*

As articulated in the sequential testing strategy (see Annex 1), it is strongly recommended that the *in vivo* test be performed initially using one animal.

If the results of this test indicate the substance to be corrosive or a severe irritant to the eye using the procedure described, further testing for ocular irritancy should not be performed.

#### 1.4.2.5 *Local anaesthetics*

Local anaesthetics may be used on a case-by-case basis. If the weight-of-the-evidence analysis indicates that the substance has the potential to cause pain, or initial testing shows that a painful reaction will occur, a local anaesthetic may be used prior to instillation of the test substance. The type, concentration, and dose of the local anaesthetic should be carefully selected to ensure that differences in reaction to the test substance will not result from its use. The control eye should be similarly anaesthetised.

#### 1.4.2.6 *Confirmatory test (In vivo eye irritation test with additional animals)*

If a corrosive effect is not observed in the initial test, the irritant or negative response should be confirmed using up to two additional animals. If a severe irritant effect is observed in the initial test indicating a possible strong (irreversible) effect in the confirmatory testing, it is recommended that the confirmatory test be conducted in a sequential manner in one animal at a time, rather than exposing the two additional animals simultaneously. If the second animal reveals corrosive or severe irritant effects, the test is not continued. Additional animals may be needed to confirm weak or moderate irritant responses.

#### 1.4.2.7 *Observation period*

The duration of the observation period should be sufficient to evaluate fully the magnitude and reversibility of the effects observed. However, the experiment should be terminated at any time that the animal shows continuing signs of severe pain or distress (9). To determine reversibility of effects, the animals should be observed normally for 21 days post administration of the test substance. If reversibility is seen before 21 days, the experiment should be terminated at that time.

#### 1.4.2.7.1 Clinical observations and grading of eye reactions

The eyes should be examined at 1, 24, 48, and 72 hours after test substance application. Animals should be kept on test no longer than necessary once definitive information has been obtained. Animals showing continuing severe pain or distress should be humanely killed without delay, and the substance assessed accordingly. Animals with the following eye lesions post-instillation should be humanely killed: corneal perforation or significant corneal ulceration including staphyloma; blood in the anterior chamber of the eye; grade 4 corneal opacity which persists for 48 hours; absence of a light reflex (iridial response grade 2) which persists for 72 hours; ulceration of the conjunctival membrane; necrosis of the conjunctivae or nictitating membrane; or sloughing. This is because such lesions generally are not reversible

Animals that do not develop ocular lesions may be terminated not earlier than 3 days post instillation. Animals with mild to moderate lesions should be observed until the lesions clear, or for 21 days, at which time the study is terminated. Observations should be performed at 7, 14, and 21 days in order to determine the status of the lesions, and their reversibility or irreversibility.

The grades of ocular reaction (conjunctivae, cornea and iris) should be recorded at each examination (Table I). Any other lesions in the eye (e.g. pannus, staining) or adverse systemic effects should also be reported.

Examination of reactions can be facilitated by use of a binocular loupe, hand slit-lamp, biomicroscope, or other suitable device. After recording the observations at 24 hours, the eyes may be further examined with the aid of fluorescein.

The grading of ocular responses is necessarily subjective. To promote harmonisation of grading of ocular response and to assist testing laboratories and those involved in making and interpreting the observations, the personnel performing the observations need to be adequately trained in the scoring system used.

## 2. DATA

### 2.2 EVALUATION OF RESULTS

The ocular irritation scores should be evaluated in conjunction with the nature and severity of lesions, and their reversibility or lack of reversibility. The individual scores do not represent an absolute standard for the irritant properties of a material, as other effects of the test material are also evaluated. Instead, individual scores should be viewed as reference values and are only meaningful when supported by a full description and evaluation of all observations.

## 3. REPORTING

### 3.1 TEST REPORT

The test report must include the following information:

Rationale for *in vivo* testing: weight-of-the-evidence analysis of pre-existing test data, including results from sequential testing strategy

- description of relevant data available from prior testing;
- data derived in each step of testing strategy;
- description of *in vitro* tests performed, including details of procedures, results obtained with test/reference substances;
- description of *in vivo* dermal irritation/corrosion study performed, including results obtained;
- weight-of-the-evidence analysis for performing *in vivo* study



## Test substance:

- identification data (e.g., CAS number, source, purity, known impurities, lot number);
- physical nature and physicochemical properties (e.g. pH, volatility, solubility, stability, reactivity with water);
- in case of a mixture, composition and relative percentages of components;
- if local anaesthetic is used, identification, purity, type, dose, and potential interaction with test substance.

## Vehicle:

- identification, concentration (where appropriate), volume used;
- justification for choice of vehicle.

## Test animals:

- species/strain used, rationale for using animals other than albino rabbit;
- age of each animal at start of study;
- number of animals of each sex in test and control groups (if required);
- individual animal weights at start and conclusion of test;
- source, housing conditions, diet, etc.

## Results:

- description of method used to score irritation at each observation time (e.g., hand slitlamp, biomicroscope, fluorescein);
- tabulation of irritant/corrosive response data for each animal at each observation time up to removal of each animal from the test;
- narrative description of the degree and nature of irritation or corrosion observed;
- description of any other lesions observed in the eye (e.g., vascularization, pannus formation, adhesions, staining);
- description of non-ocular local and systemic adverse effects, and histopathological findings, if any.

## Discussion of results.

## 3.2

## INTERPRETATION OF THE RESULTS

Extrapolation of the results of eye irritation studies in laboratory animals to humans is valid only to a limited degree. In many cases the albino rabbit is more sensitive than humans to ocular irritants or corrosives.

Care should be taken in the interpretation of data to exclude irritation resulting from secondary infection.

4.

**REFERENCES**

- (1) Barratt, M.D., Castell, J.V., Chamberlain, M., Combes, R.D., Dearden, J.C., Fentem, J.H., Gerner, I., Giuliani, A., Gray, T.J.B., Livingston, D.J., Provan, W.M., Rutten, F.A.J.J.L., Verhaar, H.J.M., Zbinden, P. (1995) The Integrated Use of Alternative Approaches for Predicting Toxic Hazard. ECVAM Workshop Report 8. ATLA 23, 410- 429.
- (2) de Silva, O., Cottin, M., Dami, N., Roguet, R., Catroux, P., Toufic, A., Sicard, C., Dossou, K.G., Gerner, I., Schlede, E., Spielmann, H., Gupta, K.C., Hill, R.N. (1997) Evaluation of Eye Irritation Potential: Statistical Analysis and Tier Testing Strategies. Food Chem. Toxicol 35, 159-164.
- (3) Worth A.P. and Fentem J.H. (1999) A general approach for evaluating stepwise testing strategies ATLA 27, 161-177.
- (4) Young, J.R., How, M.J., Walker, A.P., Worth W.M.H. (1988) Classification as Corrosive or Irritant to Skin of Preparations Containing Acidic or Alkaline Substance Without Testing on Animals. Toxicol. *In Vitro*, 2, 19 - 26.
- (5) Neun, D.J. (1993) Effects of Alkalinity on the Eye Irritation Potential of Solutions Prepared at a Single pH. J. Toxicol. Cut. Ocular Toxicol. 12, 227 - 231.
- (6) Fentem, J.H., Archer, G.E.B., Balls, M., Botham, P.A., Curren, R.D., Earl, L.K., Edsaile, D.J., Holzhutter, H.G. and Liebsch, M. (1998) The ECVAM international validation study on in vitro tests for skin corrosivity. 2. Results and evaluation by the Management Team. Toxicology in Vitro 12, pp. 483-524.
- (6a) Testing Method B.40 Skin Corrosion.
- (7) Testing method B.4. Acute toxicity: dermal irritation/corrosion.
- (8) OECD (1996) OECD Test Guidelines Programme: Final Report of the OECD Workshop on Harmonization of Validation and Acceptance Criteria for Alternative Toxicological Test Methods. Held in Solna, Sweden, 22-24 January 1996 (<http://www.oecd.org/ehs/test/background.htm>).
- (9) OECD (1998) Harmonized Integrated Hazard Classification System for Human Health and Environmental Effects of Chemical Substances, as endorsed by the 28th Joint Meeting of the Chemicals Committee and the Working Party on Chemicals, November 1998 (<http://www.oecd.org/ehs/Class/HCL6.htm>).
- (10) Guidance Document on the Recognition, Assessment and Use of Clinical Signs as Humane Endpoints for Experimental Animals Used in Safety Evaluation. OECD Environmental Health and Safety Publications. Series on Testing and Assessment No. 19 (<http://www.oecd.org/ehs/test/monos.htm>).

TABLE I: GRADING OF OCULAR LESIONS

**Cornea**

Opacity: degree of density (readings should be taken from most dense area) (\*)

|   |   |
|---|---|
| No ulceration or opacity .....  | 0 |
| Scattered or diffuse areas of opacity (other than slight dulling of normal lustre); details of iris clearly visible ..... | 1 |
| Easily discernible translucent area; details of iris slightly obscured .....  | 2 |
| Nacrous area; no details of iris visible; size of pupil barely discernible .....  | 3 |
| Opaque cornea; iris not discernible through the opacity .....   | 4 |

Maximum possible: 4

(\*) The area of corneal opacity should be noted

**Iris**

|  |   |
|--|---|
| Normal .....   | 0 |
| Markedly deepened rugae, congestion, swelling, moderate circumcorneal hyperaemia; or injection; iris reactive to light (a sluggish reaction is considered to be an effect) ..... | 1 |
| Hemorrhage, gross destruction, or no reaction to light .....   | 2 |

Maximum possible: 2

**Conjunctivae**

Redness (refers to palpebral and bulbar conjunctivae; excluding cornea and iris)

|  |   |
|--|---|
| Normal .....   | 0 |
| Some blood vessels hyperaemic (injected) .....                           | 1 |
| Diffuse, crimson colour; individual vessels not easily discernible ..... | 2 |
| Diffuse beefy red .....  | 3 |

Maximum possible: 3

**Chemosis**

Swelling (refers to lids and/or nictating membranes)

|   |   |
|---|---|
| Normal .....  | 0 |
| Some swelling above normal .....                      | 1 |
| Obvious swelling, with partial eversion of lids ..... | 2 |
| Swelling, with lids about half closed .....           | 3 |
| Swelling, with lids more than half closed .....       | 4 |

Maximum possible: 4

—

## ANNEX

**A Sequential Testing Strategy for Eye Irritation and Corrosion****GENERAL CONSIDERATIONS**

In the interests of sound science and animal welfare, it is important to avoid the unnecessary use of animals, and to minimise testing that is likely to produce severe responses in animals. All information on a substance relevant to its potential ocular irritation/corrosivity should be evaluated prior to considering *in vivo* testing. Sufficient evidence may already exist to classify a test substance as to its eye irritation or corrosion potential without the need to conduct testing in laboratory animals. Therefore, utilizing a weight-of-the-evidence analysis and sequential testing strategy will minimise the need for *in vivo* testing, especially if the substance is likely to produce severe reactions.

It is recommended that a weight-of-the-evidence analysis be used to evaluate existing information pertaining to eye irritation and corrosion of substances and to determine whether additional studies, other than *in vivo* eye studies, should be performed to help characterise such potential. Where further studies are needed, it is recommended that the sequential testing strategy be utilised to develop the relevant experimental data. For substances which have no testing history, the sequential testing strategy should be utilised to develop the data needed to evaluate its eye corrosion/irritation. The testing strategy described in this Annex was developed at an OECD workshop (1). It was subsequently affirmed and expanded in the Harmonised Integrated Hazard Classification System for Human Health and Environmental Effects of Chemical Substances, as endorsed by the 28th Joint Meeting of the Chemicals Committee and the Working Party on Chemicals, in November 1998 (2).

Although this testing strategy is not an integrated part of testing method B.5, it expresses the recommended approach for the determination of eye irritation/corrosion properties. This approach represents both best practice and an ethical benchmark for *in vivo* testing for eye irritation/corrosion. The Testing method provides guidance for the conduct of the *in vivo* test and summarises the factors that should be addressed before considering such a test. The sequential testing strategy provides a weight-of-the-evidence approach for the evaluation of existing data on the eye irritation/corrosion properties of substances and a tiered approach for the generation of relevant data on substances for which additional studies are needed or for which no studies have been performed. The strategy includes the performance first of validated and accepted *in vitro* or *ex vivo* tests and then of testing method B.4 skin irritation/corrosion studies under specific circumstances (3)(4).

**DESCRIPTION OF THE STEPWISE TESTING STRATEGY**

Prior to undertaking tests as part of the sequential testing strategy (Figure), all available information should be evaluated to determine the need for *in vivo* eye testing. Although significant information might be gained from the evaluation of single parameters (e.g., extreme pH), the totality of existing information should be assessed. All relevant data on the effects of the substance in question, and its structural analogues, should be evaluated in making a weight-of-the-evidence decision, and a rationale for the decision should be presented. Primary emphasis should be placed upon existing human and animal data on the substance, followed by the outcome of *in vitro* or *ex vivo* testing. *In vivo* studies of corrosive substances should be avoided whenever possible. The factors considered in the testing strategy include:

*Evaluation of existing human and animal data (Step 1).* Existing human data, e.g. clinical and occupational studies, and case reports, and/or animal test data from ocular studies should be considered first, because they provide information directly related to effects on the eyes. Thereafter, available data from human and/or animal studies investigating dermal corrosion/irritation should be evaluated. Substances with known corrosivity or severe irritancy to the eye should not be instilled into the eyes of animals, nor should substances showing corrosive or irritant effects to the skin; such substances should be considered to be corrosive and/or irritating to the eyes as well. Substances with sufficient evidence of non-corrosivity and non-irritancy from previously performed ocular studies should also not be tested in *in vivo* eye studies.

*Analysis of structure activity relationships (SAR) (Step 2).* The results of testing of structurally related chemicals should be considered, if available. When sufficient human and/or animal data are available on structurally related substances or mixtures of such substances to indicate their eye corrosion/irritancy potential, it can be presumed that the test substance will produce the same responses. In those cases, the substance may not need to be tested. Negative data from studies of structurally related substances or mixtures of such substances do not constitute sufficient evidence of non-corrosivity/non-irritancy of a substance under the sequential testing strategy. Validated and accepted SAR approaches should be used to identify the corrosion and irritation potential for both dermal and ocular effects.

*Physicochemical properties and chemical reactivity (Step 3).* Substances exhibiting pH extremes such as  $\leq 2.0$  or  $\geq 11.5$  may have strong local effects. If extreme pH is the basis for identifying a substance as corrosive or irritant to the eye, then its acid/alkaline reserve (buffering capacity) may also be taken into consideration (5)(6). If the buffering capacity suggests that a substance may not be corrosive to the eye, then further testing should be undertaken to confirm this, preferably by the use of a validated and accepted *in vitro* or *ex vivo* test (see section step 5 and 6).

*Consideration of other existing information (Step 4).* All available information on systemic toxicity via the dermal route should be evaluated at this stage. The acute dermal toxicity of the test substance should also be considered. If the test substance has been shown to be very toxic by the dermal route, it may not need to be tested in the eye. Although there is not necessarily a relationship between acute dermal toxicity and eye irritation/corrosion, it can be assumed that if an agent is very toxic via the dermal route, it will also exhibit high toxicity when instilled into the eye. Such data may also be considered between Steps 2 and 3.

*Results from in vitro or ex vivo tests (Steps 5 and 6).* Substances that have demonstrated corrosive or severe irritant properties in an *in vitro* or *ex vivo* test (7)(8) that has been validated and accepted for the assessment specifically of eye or skin corrosivity/irritation, need not be tested in animals. It can be presumed that such substances will produce similar severe effects *in vivo*. If validated and accepted *in vitro/ex vivo* tests are not available, one should bypass Steps 5 and 6 and proceed directly to Step 7.

*Assessment of in vivo dermal irritancy or corrosivity of the substance (Step 7).* When insufficient evidence exists with which to perform a conclusive weight-of-the-evidence analysis of the potential eye irritation/corrosivity of a substance based upon data from the studies listed above, the *in vivo* skin irritation/corrosion potential should be evaluated first, using testing method B.4 (4) and its accompanying Annex (9). If the substance is shown to produce corrosion or severe skin irritation, it should be considered to be a corrosive eye irritant unless other information supports an alternative conclusion. Thus, an *in vivo* eye test would not need to be performed. If the substance is not corrosive or severely irritating to the skin, an *in vivo* eye test should be performed.

*In vivo test in rabbits (Steps 8 and 9): In vivo ocular testing* should begin with an initial test using one animal. If the results of this test indicate the substance to be a severe irritant or corrosive to the eyes, further testing should not be performed. If that test does not reveal any corrosive or severe irritant effects, a confirmatory test is conducted with two additional animals.

## REFERENCES

- (1) OECD (1996) OECD Test Guidelines Programme: Final Report of the OECD Workshop on Harmonization of Validation and Acceptance Criteria for Alternative Toxicological Test Methods. Held in Solna, Sweden, 22-24 January 1996 (<http://www1.oecd.org/ehs/test/background.htm>).
- (2) OECD (1998) Harmonized Integrated Hazard Classification System for Human Health and Environmental Effects of Chemical Substances, as endorsed by the 28th Joint Meeting of the Chemicals Committee and the Working Party on Chemicals, November 1998 (<http://www1.oecd.org/ehs/Class/HCL6.htm>).
- (3) Worth, A.P. and Fentem J.H. (1999). A General Approach for Evaluating Stepwise Testing Strategies. *ATLA* 27, 161-177.
- (4) Testing method B.4. Acute Toxicity: dermal irritation/corrosion.
- (5) Young, J.R., How, M.J., Walker, A.P., Worth W.M.H. (1988) Classification as Corrosive or Irritant to Skin of Preparations Containing Acidic or Alkaline Substance Without Testing on Animals. *Toxicol. In Vitro*, 2, 19-26.
- (6) Neun, D.J. (1993) Effects of Alkalinity on the Eye Irritation Potential of Solutions Prepared at a Single pH. *J. Toxicol. Cut. Ocular Toxicol.* 12, 227-231.
- (7) Fentem, J.H., Archer, G.E.B., Balls, M., Botham, P.A., Curren, R.D., Earl, L.K., Edsail, D.J., Holzhutter, H.G. and Liebsch, M. (1998) The ECVAM international validation study on *in vitro* tests for skin corrosivity. 2. Results and evaluation by the Management Team. *Toxicology in Vitro* 12, pp. 483-524.
- (8) Testing Method B.40 Skin Corrosion.
- (9) Annex to Testing method B.4: A Sequential Testing Strategy for Skin Irritation and Corrosion.

FIGURE

## TESTING AND EVALUATION STRATEGY FOR EYE IRRITATION/CORROSION

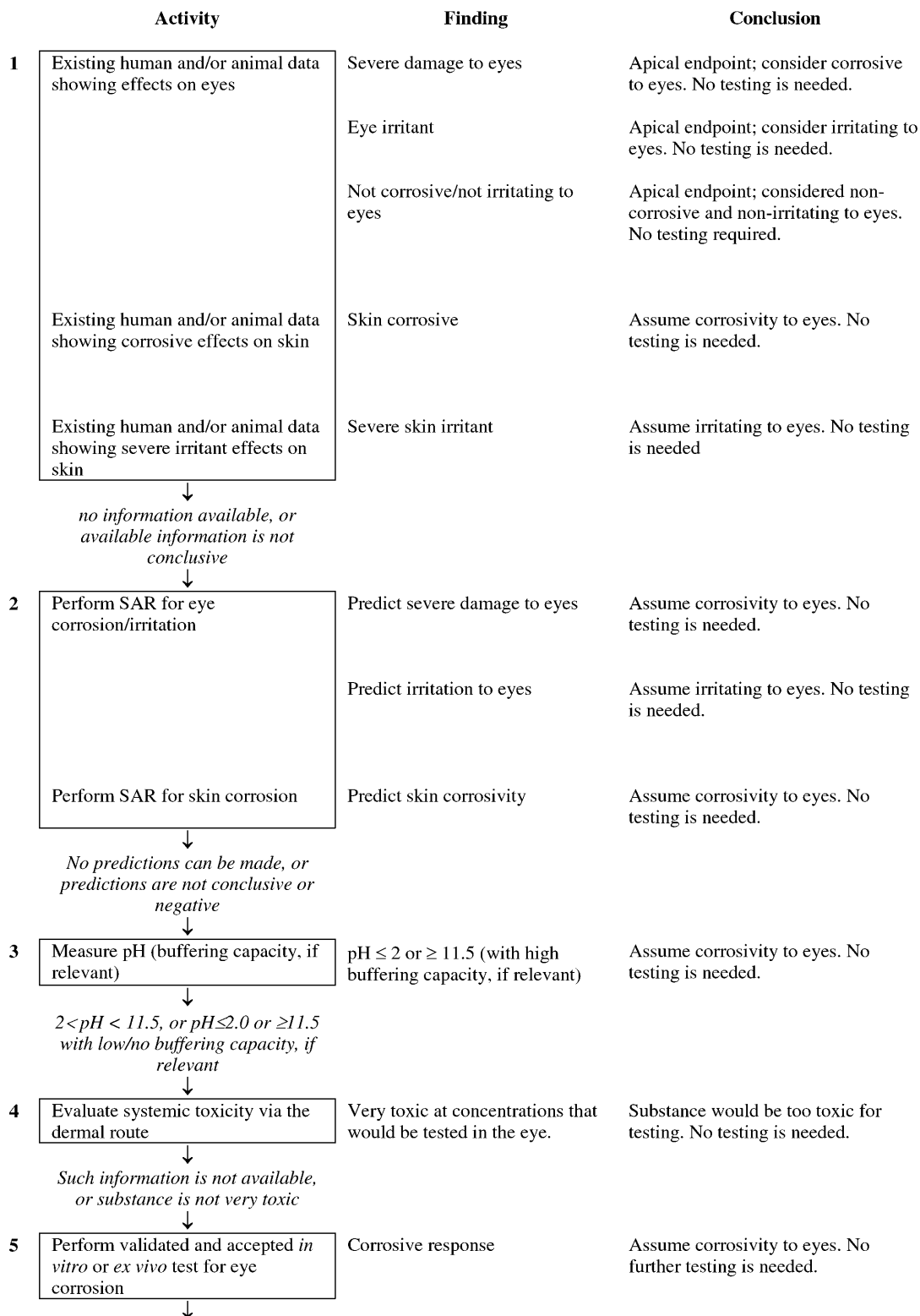

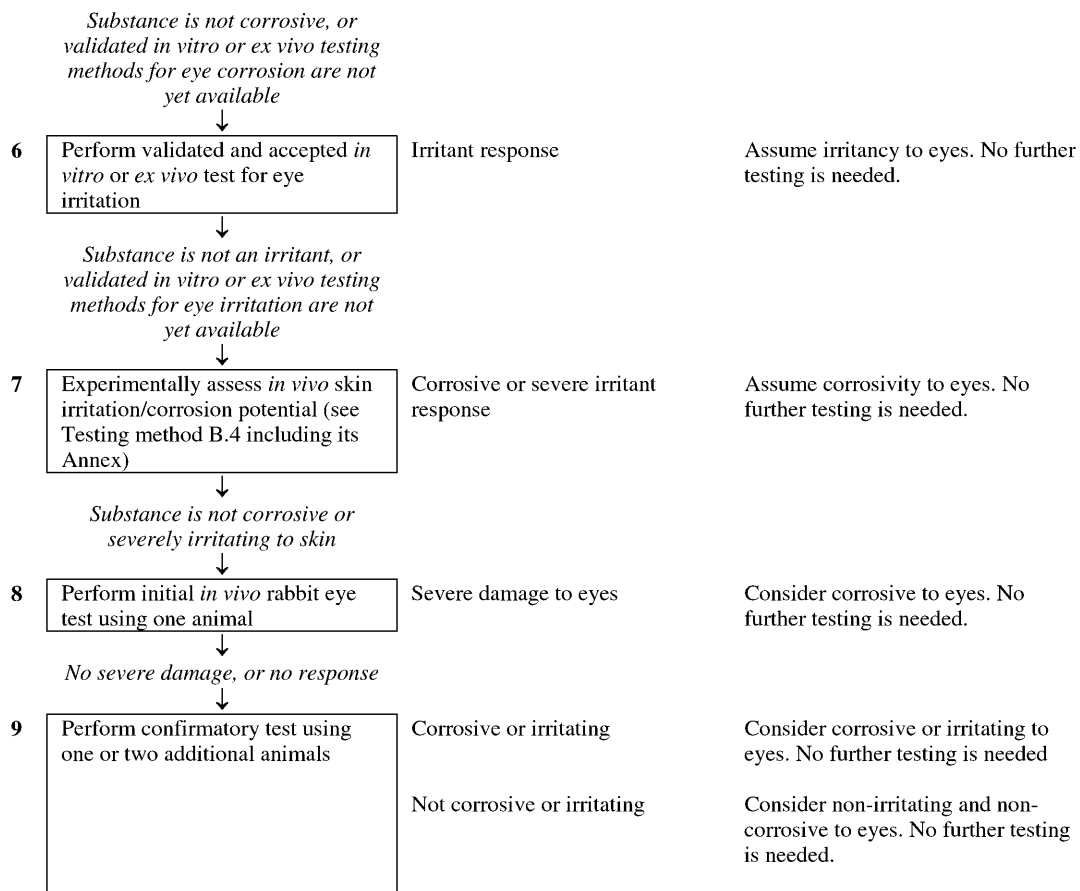

## ANNEX 2F

## B.31. PRENATAL DEVELOPMENTAL TOXICITY STUDY

## 1. METHOD

This method is a replicate of OECD TG 414 (2001).

## 1.1 INTRODUCTION

This method for developmental toxicity testing is designed to provide general information concerning the effects of prenatal exposure on the pregnant test animal and on the developing organism in utero; this may include assessment of maternal effects as well as death, structural abnormalities, or altered growth in the foetus. Functional deficits, although an important part of development, are not an integral part of this test method. They may be tested for in a separate study or as an adjunct to this study using the test method for developmental neurotoxicity. For information on testing for functional deficiencies and other postnatal effects the Test Method for the two-generation reproductive toxicity study and the developmental neurotoxicity study should be consulted as appropriate.

This test method may require specific adaptation in individual cases on the basis of specific knowledge on e.g. physicochemical or toxicological properties of the test substance. Such adaptation is acceptable, when convincing scientific evidence suggests that the adaptation will lead to a more informative test. In such a case, this scientific evidence should be carefully documented in the study report.

## 1.2 DEFINITIONS

**Developmental toxicology:** the study of adverse effects on the developing organism that may result from exposure prior to conception, during prenatal development, or postnatally to the time of sexual maturation. The major manifestations of developmental toxicity include 1) death of the organism, 2) structural abnormality, 3) altered growth, and 4) functional deficiency. Developmental toxicology was formerly often referred to as teratology.

**Adverse effect:** any treatment-related alteration from baseline that diminishes an organism's ability to survive, reproduce or adapt to the environment. Concerning developmental toxicology, taken in its widest sense it includes any effect which interferes with normal development of the conceptus, both before and after birth.

**Altered growth:** an alteration in offspring organ or body weight or size.

**Alterations (anomalies):** structural alterations in development that include both malformations and variations (28).

**Malformation/Major Abnormality:** Structural change considered detrimental to the animal (may also be lethal) and is usually rare.

**Variation/Minor Abnormality:** Structural change considered to have little or no detrimental effect on the animal; may be transient and may occur relatively frequently in the control population.

**Conceptus:** the sum of derivatives of a fertilised ovum at any stage of development from fertilisation until birth including the extra-embryonic membranes as well as the embryo or foetus.

**Implantation (nidation):** attachment of the blastocyst to the epithelial lining of the uterus, including its penetration through the uterine epithelium, and its embedding in the endometrium.

**Embryo:** the early or developing stage of any organism, especially the developing product of fertilisation of an egg after the long axis appears and until all major structures are present.



**Embryotoxicity:** detrimental to the normal structure, development, growth, and/or viability of an embryo.

**Foetus:** the unborn offspring in the post-embryonic period.

**Foetotoxicity:** detrimental to the normal structure, development, growth, and/or viability of a foetus.

**Abortion:** the premature expulsion from the uterus of the products of conception: of the embryo or of a nonviable foetus.

**Resorption:** a conceptus which, having implanted in the uterus, subsequently died and is being, or has been resorbed.

**Early resorption:** evidence of implantation without recognisable embryo/foetus

**Late resorption:** dead embryo or foetus with external degenerative changes

**NOAEL:** abbreviation for no-observed-adverse-effect level and is the highest dose or exposure level where no adverse treatment-related findings are observed.

### 1.3 REFERENCE SUBSTANCE

None.

### 1.4 PRINCIPLE OF THE TEST METHOD

Normally, the test substance is administered to pregnant animals at least from implantation to one day prior to the day of scheduled kill, which should be as close as possible to the normal day of delivery without risking loss of data resulting from early delivery. The test method is not intended to examine solely the period of organogenesis, (e.g. days 5-15 in the rodent, and days 6-18 in the rabbit) but also effects from preimplantation, when appropriate, through the entire period of gestation to the day before caesarean section. Shortly before caesarean section, the females are killed, the uterine contents are examined, and the foetuses are evaluated for externally visible anomalies and for soft tissue and skeletal changes.

### 1.5 DESCRIPTION OF THE TEST METHOD

#### 1.5.1 Selection of animal species

It is recommended that testing be performed in the most relevant species, and that laboratory species and strains which are commonly used in prenatal developmental toxicity testing be employed. The preferred rodent species is the rat and the preferred non-rodent species is the rabbit. Justification should be provided if another species is used.

#### 1.5.2 Housing and feeding conditions

The temperature in the experimental animal room should be 22 °C ( $\pm$  3°) for rodents and 18 °C ( $\pm$  3°) for rabbits. Although the relative humidity should be at least 30 % and preferably not exceed 70 % other than during room cleaning, the aim should be 50-60 %. Lighting should be artificial, the sequence being 12 hours light, 12 hours dark. For feeding, conventional laboratory diets may be used with an unlimited supply of drinking water.

Mating procedures should be carried out in cages suitable for the purpose. While individual housing of mated animals is preferred, group housing in small numbers is also acceptable.

#### 1.5.3 Preparation of the animals

Healthy animals, which have been acclimated to laboratory conditions for at least 5 days and have not been subjected to previous experimental procedures, should be used. The test animals should be characterised as to species, strain, source, sex, weight and/or age. The animals of all test groups should, as nearly as practicable, be of uniform weight and age. Young adult nulliparous female animals should be

used at each dose level. The females should be mated with males of the same species and strain, and the mating of siblings should be avoided. For rodents day 0 of gestation is the day on which a vaginal plug and/or sperm are observed; for rabbits day 0 is usually the day of coitus or of artificial insemination, if this technique is used. Mated females should be assigned in an unbiased manner to the control and treatment groups. Cages should be arranged in such a way that possible effects due to cage placement are minimised. Each animal should be assigned a unique identification number. Mated females should be assigned in an unbiased manner to the control and treatment groups, and if the females are mated in batches, the animals in each batch should be evenly distributed across the groups. Similarly, females inseminated by the same male should be evenly distributed across the groups.

## 1.6 PROCEDURE

### 1.6.1 **Number and sex of animals**

Each test and control group should contain a sufficient number of females to result in approximately 20 female animals with implantation sites at necropsy. Groups with fewer than 16 animals with implantation sites may be inappropriate. Maternal mortality does not necessarily invalidate the study providing it does not exceed approximately 10 %.

### 1.6.2 **Preparation of doses**

If a vehicle or other additive is used to facilitate dosing, consideration should be given to the following characteristics: effects on the absorption, distribution, metabolism, and retention or excretion of the test substance; effects on the chemical properties of the test substance which may alter its toxic characteristics; and effects on the food or water consumption or the nutritional status of the animals. The vehicle should neither be developmentally toxic nor have effects on reproduction.

### 1.6.3 **Dosage**

Normally, the test substance should be administered daily from implantation (e.g., day 5 post mating) to the day prior to scheduled caesarean section. If preliminary studies, when available, do not indicate a high potential for preimplantation loss, treatment may be extended to include the entire period of gestation, from mating to the day prior to scheduled kill. It is well known that inappropriate handling or stress during pregnancy can result in prenatal loss. To guard against prenatal loss from factors which are not treatment-related, unnecessary handling of pregnant animals as well as stress from outside factors such as noise should be avoided.

At least three dose levels and a concurrent control should be used. Healthy animals should be assigned in an unbiased manner to the control and treatment groups. The dose levels should be spaced to produce a gradation of toxic effects. Unless limited by the physical/chemical nature or biological properties of the test substance, the highest dose should be chosen with the aim to induce some developmental and/or maternal toxicity (clinical signs or a decrease in body weight) but not death or severe suffering. At least one intermediate dose level should produce minimal observable toxic effects. The lowest dose level should not produce any evidence of either maternal or developmental toxicity. A descending sequence of dose levels should be selected with a view to demonstrating any dosage-related response and no-observed-adverse-effect level (NOAEL). Two- to four-fold intervals are frequently optimal for setting the descending dose levels, and the addition of a fourth test group is often preferable to using very large intervals (e.g. more than a factor of 10) between dosages. Although establishment of a maternal NOAEL is the goal, studies which do not establish such a level may also be acceptable (1).

Dose levels should be selected taking into account any existing toxicity data as well as additional information on metabolism and toxicokinetics of the test substance or related materials. This information will also assist in demonstrating the adequacy of the dosing regimen.

A concurrent control group should be used. This group should be a sham-treated control group or a vehicle-control group if a vehicle is used in administering the test substance. All groups should be administered the same volume of either test substance or vehicle. Animals in the control group(s) should be handled in an identical manner to test group animals. Vehicle control groups should receive the vehicle in the highest amount used (as in the lowest treatment group).

### 1.6.4 **Limit test**

If a test at one dose level of at least 1 000 mg/kg body weight/day by oral administration, using the procedures described for this study, produces no observable toxicity in either pregnant animals or their progeny and if an effect would not be expected based upon existing data (e.g., from structurally and/or metabolically related compounds), then a full study using three dose levels may not be considered

necessary. Expected human exposure may indicate the need for a higher oral dose level to be used in the limit test. For other types of administration, such as inhalation or dermal application, the physico-chemical properties of the test substance often may indicate and limit the maximum attainable level of exposure (for example, dermal application should not cause severe local toxicity).

#### 1.6.5 Administration of doses

The test substance or vehicle is usually administered orally by intubation. If another route of administration is used, the tester should provide justification and reasoning for its selection, and appropriate modifications may be necessary (2)(3)(4). The test substance should be administered at approximately the same time each day.

The dose to individual animals should normally be based on the most recent individual body weight determination. However, caution should be exercised when adjusting the dose during the last trimester of pregnancy. Existing data should be used for dose selection to prevent excess maternal toxicity. However, if excess toxicity is noted in the treated dams, those animals should be humanely killed. If several pregnant animals show signs of excess toxicity, consideration should be given to terminating that dose group. When the substance is administered by gavage, this should preferably be given as a single dose to the animals using a stomach tube or a suitable intubation canula. The maximum volume of liquid that can be administered at one time depends on the size of the test animal. The volume should not exceed 1 ml/100 g body weight, except in the case of aqueous solutions where 2 ml/100 g body weight may be used. When corn oil is used as a vehicle, the volume should not exceed 0.4 ml/100 g body weight. Variability in test volume should be minimised by adjusting the concentrations to ensure a constant volume across all dose levels.

#### 1.6.6 Observations of the dams

Clinical observations should be made and recorded at least once a day, preferably at the same time(s) each day taking into consideration the peak period of anticipated effects after dosing. The condition of the animals should be recorded including mortality, moribundity, pertinent behavioural changes, and all signs of overt toxicity.

#### 1.6.7 Body weight and food consumption

Animals should be weighed on day 0 of gestation or no later than day 3 of gestation if time-mated animals are supplied by an outside breeder, on the first day of dosing, at least every 3 days during the dosing period and on the day of scheduled kill.

Food consumption should be recorded at three-day intervals and should coincide with days of body weight determination.

#### 1.6.8 Post-mortem examination

Females should be killed one day prior to the expected day of delivery. Females showing signs of abortion or premature delivery prior to scheduled kill should be killed and subjected to a thorough macroscopic examination.

At the time of termination or death during the study, the dam should be examined macroscopically for any structural abnormalities or pathological changes. Evaluation of the dams during caesarean section and subsequent foetal analyses should be conducted preferably without knowledge of treatment group in order to minimise bias.

#### 1.6.9 Examination of uterine contents

Immediately after termination or as soon as possible after death, the uteri should be removed and the pregnancy status of the animals ascertained. Uteri that appear non gravid should be further examined (e.g. by ammonium sulphide staining for rodents and Salewski staining or a suitable alternative method for rabbits) to confirm the non-pregnant status (5).

Gravid uteri including the cervix should be weighed. Gravid uterine weights should not be obtained from animals found dead during the study.

The number of corpora lutea should be determined for pregnant animals.

The uterine contents should be examined for numbers of embryonic or foetal deaths and viable foetuses. The degree of resorption should be described in order to estimate the relative time of death of the conceptus (see section 1.2).

#### 1.6.10 Examination of foetuses

The sex and body weight of each foetus should be determined.

Each foetus should be examined for external alterations (6).

Foetuses should be examined for skeletal and soft tissue alterations (e.g. variations and malformations or anomalies) (7) (8) (9) (10) (11) (12) (13) (14) (15) (16) (17) (18) (19) (20) (21) (22) (23) (24). Categorisation of foetal alterations is preferable but not required. When categorisation is done, the criteria for defining each category should be clearly stated. Particular attention should be paid to the reproductive tract which should be examined for signs of altered development.

For rodents, approximately one-half of each litter should be prepared and examined for skeletal alterations. The remainder should be prepared and examined for soft tissue alterations, using accepted or appropriate serial sectioning methods or careful gross dissection techniques.

For non-rodents, e.g. rabbits, all foetuses should be examined for both soft tissue and skeletal alterations. The bodies of these foetuses are evaluated by careful dissection for soft tissue alterations, which may include procedures to further evaluate internal cardiac structure (25). The heads of one-half of the foetuses examined in this manner should be removed and processed for evaluation of soft tissue alterations (including eyes, brain, nasal passages and tongue), using standard serial sectioning methods (26) or an equally sensitive method. The bodies of these foetuses and the remaining intact foetuses should be processed and examined for skeletal alterations, utilising the same methods as described for rodents.

## 2. DATA

### 2.1 TREATMENT OF RESULTS

Data shall be reported individually for the dams as well as for their offspring and summarised in tabular form, showing for each test group and each generation the number of animals at the start of the test, the number of animals found dead during the test or killed for humane reasons, the time of any death or humane kill, the number of pregnant females, the number of animals showing signs of toxicity, a description of the signs of toxicity observed, including time of onset, duration, and severity of any toxic effects, the types of embryo/foetal observations, and all relevant litter data.

Numerical results should be evaluated by an appropriate statistical method using the litter as the unit for data analysis. A generally accepted statistical method should be used; the statistical methods should be selected as part of the design of the study and should be justified. Data from animals that do not survive to the scheduled kill should also be reported. These data may be included in group means where relevant. Relevance of the data obtained from such animals, and therefore inclusion or exclusion from any group mean(s), should be justified and judged on an individual basis.

### 2.2 EVALUATION OF RESULTS

The findings of the Prenatal Developmental Toxicity Study should be evaluated in terms of the observed effects. The evaluation will include the following information:

- maternal and embryo/foetal test results, including the evaluation of the relationship, or lack thereof, between the exposure of the animals to the test substance and the incidence and severity of all findings;

- criteria used for categorising foetal external, soft tissue, and skeletal alterations if categorisation has been done;
- when appropriate, historical control data to enhance interpretation of study results;
- the numbers used in calculating all percentages or indices;
- adequate statistical analysis of the study findings, when appropriate, which should include sufficient information on the method of analysis, so that an independent reviewer/statistician can re-evaluate and reconstruct the analysis;

In any study which demonstrates the absence of any toxic effects, further investigations to establish absorption and bioavailability of the test substance should be considered.

### 2.3 INTERPRETATION OF RESULTS

A prenatal developmental toxicity study will provide information on the effects of repeated exposure to a substance during pregnancy on the dams and on the intrauterine development of their progeny. The results of the study should be interpreted in conjunction with the findings from subchronic, reproduction, toxicokinetic and other studies. Since emphasis is placed on both general toxicity in terms of maternal toxicity and on developmental toxicity endpoints, the results of the study will allow to a certain extent for the discrimination between developmental effects occurring in the absence of general toxicity and those which are only induced at levels that are also toxic to the maternal animal (27).

## 3. REPORTING

### 3.1 TEST REPORT

The test report must include the following specific information:

Test substance:

- physical nature and, where relevant, physiochemical properties;
- identification including CAS number if known/established;
- purity.

Vehicle (if appropriate):

- justification for choice of vehicle, if other than water.

Test animals:

- species and strain used;
- number and age of animals;
- source, housing conditions, diet, etc.;
- individual weights of animals at the start of the test.

Test conditions:

- rationale for dose level selection;
- details of test substance formulation/diet preparation, achieved concentration, stability and homogeneity of the preparation;
- details of the administration of the test substance;

- conversion from diet/drinking water test substance concentration (ppm) to the actual dose (mg/kg body weight/day), if applicable;
- environmental conditions;
- details of food and water quality.

Results:

Maternal toxic response data by dose, including but not limited to:

- the number of animals at the start of the test, the number of animals surviving, the number pregnant, and the number aborting, number of animals delivering early;
- day of death during the study or whether animals survived to termination;
- data from animals that do not survive to the scheduled kill should be reported but not included in the inter-group statistical comparisons;
- day of observation of each abnormal clinical sign and its subsequent course;
- body weight, body weight change and gravid uterine weight, including, optionally, body weight change corrected for gravid uterine weight;
- food consumption and, if measured, water consumption;
- necropsy findings, including uterine weight;
- NOAEL values for maternal and developmental effects should be reported.

Developmental endpoints by dose for litters with implants, including:

- number of corpora lutea;
- number of implantations, number and percent of live and dead fetuses and resorptions;
- number and percent of pre- and post-implantation losses.

Developmental endpoints by dose for litters with live fetuses, including:

- number and percent of live offspring;
- sex ratio;
- foetal body weight, preferably by sex and with sexes combined;
- external, soft tissue, and skeletal malformations and other relevant alterations;
- criteria for categorisation if appropriate;
- total number and percent of fetuses and litters with any external, soft tissue, or skeletal alteration, as well as the types and incidences of individual anomalies and other relevant alterations.

Discussion of results.

Conclusions.

4.

**REFERENCES**

- (1) Kavlock R.J. et al. (1996) A Simulation Study of the Influence of Study Design on the Estimation of Benchmark Doses for Developmental Toxicity. *Risk Analysis* 16; 399-410.
- (2) Kimmel, C.A. and Francis, E.Z. (1990) Proceedings of the Workshop on the Acceptability and Interpretation of Dermal Developmental Toxicity Studies. *Fundamental and Applied Toxicology* 14; 386-398.
- (3) Wong, B.A., et al. (1997) Developing Specialized Inhalation Exposure Systems to Address Toxicological Problems. *CIIT Activities* 17; 1-8.
- (4) US Environmental Protection Agency (1985) Subpart E-Specific Organ/Tissue Toxicity, 40 CFR 798.4350: Inhalation Developmental Toxicity Study.
- (5) Salewski, E. (1964) Faerbermethode zum Makroskopischen Nachweis von Implantations Stellen am Uterusder Ratte. *Naunyn-Schmeidebergs Archiv fur Pharmakologie und Experimentelle Pathologie* 247:367.
- (6) Edwards, J.A. (1968) The external Development of the Rabbit and Rat Embryo. In *Advances in Teratology*. D.H.M. Woolam (ed.) Vol. 3. Academic Press, NY.
- (7) Inouye, M. (1976) Differential Staining of Cartilage and Bone in Fetal Mouse Skeleton by Alcian Blue and Alizarin Red S. *Congenital Anomalies* 16; 171-173.
- (8) Igarashi, E. et al. (1992) Frequency Of Spontaneous Axial Skeletal Variations Detected by the Double Staining Techniquefor Ossified and Cartilaginous Skeleton in Rat Foetuses. *Congenital Anomalies* 32; :381-391.
- (9) Kimmel, C.A. et al. (1993) Skeletal Development Following Heat Exposure in the Rat. *Teratology* 47:229-242.
- (10) Marr, M.C. et al. (1988) Comparison of Single and Double Staining for Evaluation of Skeletal Development: The Effects of Ethylene Glycol (EG) in CD Rats. *Teratology* 37; 476.
- (11) Barrow, M.V. and Taylor, W.J. (1969) A Rapid Method for Detecting Malformations in Rat Foetuses. *Journal of Morphology* 127:291-306.
- (12) Fritz, H. (1974) Prenatal Ossification in Rabbits ss Indicative of Foetal Maturity. *Teratology* 11; 313-320.
- (13) Gibson, J.P. et al. (1966) Use of the Rabbit in Teratogenicity Studies. *Toxicology and Applied Pharmacology* 9; :398-408.
- (14) Kimmel, C.A. and Wilson, J.G. (1973) Skeletal Deviation in Rats: Malformations or Variations? *Teratology* 8; 309-316.
- (15) Marr, M.C. et al. (1992) Developmental Stages of the CD (Sprague-Dawley) Rat Skeleton after Maternal Exposure to Ethylene Glycol. *Teratology* 46; 169-181.
- (16) Monie, I.W. et al. (1965) Dissection Procedures for Rat Foetuses Permitting Alizarin Red Staining of Skeleton and Histological Study of Viscera. *Supplement to Teratology Workshop Manual*, pp. 163-173.
- (17) Spark, C. and Dawson, A.B. (1928) The Order and Time of appearance of Centers of Ossification in the Fore and Hind Limbs of the Albino Rat, with Special Reference to the Possible Influence of the Sex Factor. *American Journal of Anatomy* 41; 411-445.
- (18) Staples, R.E. and Schnell, V.L. (1964) Refinements in Rapid Clearing Technique in the KOH-Alizarin Red S Method for Fetal Bone. *Stain Technology* 39; 61-63.
- (19) Strong, R.M. (1928) The Order Time and Rate of Ossification of the Albino Rat (Mus Norvegicus Albinus) Skeleton. *American Journal of Anatomy* 36; 313-355.
- (20) Stuckhardt, J.L. and Poppe, S.M. (1984) Fresh Visceral Examination of Rat and Rabbit Foetuses Used in Teratogenicity Testing. *Teratogenesis, Carcinogenesis, and Mutagenesis* 4; 181-188.
- (21) Walker, D.G. and Wirtschafter, Z.T. (1957) *The Genesis of the Rat Skeleton*. Thomas, Springfield, IL.

- (22) Wilson, J.G. (1965) Embryological Considerations in Teratology. In *Teratology: Principles and Techniques*, Wilson J.G. and Warkany J. (eds). University of Chicago, Chicago, IL, pp 251-277.
  - (23) Wilson, J.G. and Fraser, F.C. (eds). (1977) *Handbook of Teratology*, Vol. 4. Plenum, NY.
  - (24) Varnagy, L. (1980) Use of Recent Fetal Bone Staining Techniques in the Evaluation of Pesticide Teratogenicity. *Acta Vet. Acad. Sci. Hung.* 28; 233-239.
  - (25) Staples, R.E. (1974) Detection of visceral Alterations in Mammalian Foetuses. *Teratology* 9; 37-38.
  - (26) Van Julsingha, E.B. and C.G. Bennett (1977) A Dissecting Procedure for the Detection of Anomalies in the Rabbit Foetal Head. In: *Methods in Prenatal Toxicology* Neubert, D., Merker, H.J. and Kwasigroch, T.E. (eds.). University of Chicago, Chicago, IL, pp. 126-144.
  - (27) US Environmental Protection Agency (1991) Guidelines for Developmental Toxicity Risk Assessment. *Federal Register* 56; 63798-63826.
  - (28) Wise, D.L. et al. (1997) Terminology of Developmental Abnormalities in Common Laboratory Mammals (Version 1) *Teratology* 55; 249-292.
-



## ANNEX 2G

**B.35. TWO-GENERATION REPRODUCTION TOXICITY STUDY****1. METHOD**

This method is a replicate of the OECD TG 416 (2001).

**1.1 INTRODUCTION**

This method for two-generation reproduction testing is designed to provide general information concerning the effects of a test substance on the integrity and performance of the male and female reproductive systems, including gonadal function, the oestrus cycle, mating behaviour, conception, gestation, parturition, lactation, and weaning, and the growth and development of the offspring. The study may also provide information about the effects of the test substance on neonatal morbidity, mortality, and preliminary data on prenatal and postnatal developmental toxicity and serve as a guide for subsequent tests. In addition to studying growth and development of the F1 generation, this test method is also intended to assess the integrity and performance of the male and female reproductive systems as well as growth and development of the F2 generation. For further information on developmental toxicity and functional deficiencies, either additional study segments can be incorporated into this protocol, consulting the methods for developmental toxicity and/or developmental neurotoxicity as appropriate, or these endpoints could be studied in separate studies, using the appropriate test methods.

**1.2 PRINCIPLE OF THE TEST METHOD**

The test substance is administered in graduated doses to several groups of males and females. Males of the P generation should be dosed during growth and for at least one complete spermatogenetic cycle (approximately 56 days in the mouse and 70 days in the rat) in order to elicit any adverse effects on spermatogenesis. Effects on sperm are determined by a number of sperm parameters (e.g. sperm morphology and motility) and in tissue preparation and detailed histopathology. If data on spermatogenesis are available from a previous repeated dose study of sufficient duration, e.g. a 90-day study, males of the P generation need not be included in the evaluation. It is recommended, however, that samples or digital recordings of sperm of the P generation are saved, to enable later evaluation. Females of the P generation should be dosed during growth and for several complete oestrus cycles in order to detect any adverse effects on oestrus cycle normality by the test substance. The test substance is administered to parental (P) animals during their mating, during the resulting pregnancies, and through the weaning of their F1 offspring. At weaning the administration of the substance is continued to F1 offspring during their growth into adulthood, mating and production of an F2 generation, until the F2 generation is weaned.

Clinical observations and pathological examinations are performed on all animals for signs of toxicity with special emphasis on effects on the integrity and performance of the male and female reproductive systems and on the growth and development of the offspring.

**1.3 DESCRIPTION OF THE TEST METHOD****1.3.1 Selection of animal species**

The rat is the preferred species for testing. If other species are used, justification should be given and appropriate modifications will be necessary. Strains with low fecundity or well-known high incidence of developmental defects should not be used. At the commencement of the study, the weight variation of animals used should be minimal and not exceed 20 % of the mean weight of each sex.

**1.3.2 Housing and feeding conditions**

The temperature in the experimental animal room should be 22 °C (± 3°). Although the relative humidity should be at least 30 % and preferably not exceed 70 % other than during room cleaning, the aim should

be 50-60 %. Lighting should be artificial, the sequence being 12 hours light, 12 hours dark. For feeding, conventional laboratory diets may be used with an unlimited supply of drinking water. The choice of diet may be influenced by the need to ensure a suitable admixture of a test substance when administered by this method.

Animals may be housed individually or be caged in small groups of the same sex. Mating procedures should be carried out in cages suitable for the purpose. After evidence of copulation, mated females shall be single-caged in delivery or maternity cages. Mated rats may also be kept in small groups and separated one or two days prior to parturition. Mated animals shall be provided with appropriate and defined nesting materials when parturition is near.

### 1.3.3 **Preparation of animals**

Healthy young animals, which have been acclimated to laboratory conditions for at least 5 days and have not been subjected to previous experimental procedures, should be used. The test animals should be characterised as to species, strain, source, sex, weight and/or age. Any sibling relationships among the animals should be known so that mating of siblings is avoided. The animals should be randomly assigned to the control and treated groups (stratification by body weight is recommended). Cages should be arranged in such a way that possible effects due to cage placement are minimised. Each animal should be assigned a unique identification number. For the P generation, this should be done before dosing starts. For the F1 generation, this should be done at weaning for animals selected for mating. Records indicating the litter of origin should be maintained for all selected F1 animals. In addition, individual identification of pups as soon after birth as possible is recommended when individual weighing of pups or any functional tests are considered.

Parental (P) animals shall be about 5 to 9 weeks old at the start of dosing. The animals of all test groups shall, as nearly as practicable, be of uniform weight and age.

## 1.4 PROCEDURE

### 1.4.1 **Number and sex of animals**

Each test and control group should contain a sufficient number of animals to yield preferably not less than 20 pregnant females at or near parturition. For substances that cause undesirable treatment related effects (e.g. sterility, excessive toxicity at the high dose), this may not be possible. The objective is to produce enough pregnancies to assure a meaningful evaluation of the potential of the substance to affect fertility, pregnancy and maternal behaviour and suckling, growth and development of the F1 offspring from conception to maturity, and the development of their offspring (F2) to weaning. Therefore, failure to achieve the desired number of pregnant animals (i.e. 20) does not necessarily invalidate the study and should be evaluated on a case-by-case basis.

### 1.4.2 **Preparation of Doses**

It is recommended that the test substance be administered orally (by diet, drinking water or gavage) unless another route of administration (e.g. dermal or inhalation) is considered more appropriate.

Where necessary, the test substance is dissolved or suspended in a suitable vehicle. It is recommended that, wherever possible, the use of an aqueous solution/suspension be considered first, followed by consideration of a solution/emulsion in oil (e.g. corn oil) and then by possible solution in other vehicles. For vehicles other than water, the toxic characteristics of the vehicle must be known. The stability of the test substance in the vehicle should be determined.

### 1.4.3 **Dosage**

At least three dose levels and a concurrent control shall be used. Unless limited by the physical-chemical nature or biological effects of the test substance, the highest dose level should be chosen with the aim to induce toxicity but not death or severe suffering. In case of unexpected mortality, studies with a mortality rate of less than approximately 10 percent in the parental (P) animals would normally still be acceptable. A descending sequence of dose levels should be selected with a view to demonstrating any dosage related effect and no-observed-adverse-effects levels (NOAEL). Two to four fold intervals are frequently optimal for setting the descending dose levels and addition of a fourth test group is often preferable to using very large intervals (e.g. more than a factor of 10) between dosages. For the dietary studies the dose interval

should be not more than 3 fold. Dose levels should be selected taking into account any existing toxicity data, especially results from repeated dose studies. Any available information on metabolism and kinetics of the test compound or related materials should also be considered. In addition, this information will also assist in demonstrating the adequacy of the dosing regimen.

The control group shall be an untreated group or a vehicle-control group if a vehicle is used in administering the test substance. Except for treatment with the test substance, animals in the control group should be handled in an identical manner to the test group subjects. If a vehicle is used, the control group shall receive the vehicle in the highest volume used. If a test substance is administered in the diet, and causes reduced dietary intake or utilisation, then the use of a pair-fed control group may be considered necessary. Alternatively data from controlled studies designed to evaluate the effects of decreased food consumption on reproductive parameters may be used in lieu of a concurrent pair-fed control group.

Consideration should be given to the following characteristics of vehicle and other additives: effects on the absorption, distribution, metabolism, or retention of the test substance; effects on the chemical properties of the test substance which may alter its toxic characteristics; and effects on the food or water consumption or the nutritional status of the animals.

#### 1.4.4 **Limit test**

If an oral study at one dose level of at least 1 000 mg/kg body weight/day or, for dietary or drinking water administration, an equivalent percentage in the diet or drinking water using the procedures described for this study, produces no observable toxic effects in either parental animals or their offspring and if toxicity would not be expected based upon data from structurally and /or metabolically related compounds, then a full study using several dose levels may not be considered necessary. The limit test applies except when human exposure indicates the need for a higher oral dose level to be used. For other types of administration, such as inhalation or dermal application, the physical-chemical properties of the test substance, such as solubility, often may indicate and limit the maximum attainable level of exposure.

#### 1.4.5 **Administration of doses**

The animals should be dosed with the test substance on a 7-days-a-week basis. The oral route of administration (diet, drinking water, or gavage) is preferred. If another route of administration is used, justification shall be provided, and appropriate modifications may be necessary. All animals shall be dosed by the same method during the appropriate experimental period. When the test substance is administered by gavage, this should be done using a stomach tube. The volume of liquid administered at one time should not exceed 1 ml/100 g body weight (0.4 ml/100 g body weight is the maximum for corn oil), except in the case of aqueous solutions where 2 ml/100 g body weight may be used. Except for irritant or corrosive substances, which will normally reveal exacerbated effects with higher concentrations, variability in test volume should be minimised by adjusting the concentration to ensure a constant volume at all dose levels. In gavage studies, the pups will normally only receive test substance indirectly through the milk, until direct dosing commences for them at weaning. In diet or drinking water studies, the pups will additionally receive test substance directly when they commence eating for themselves during the last week of the lactation period.

For substances administered via the diet or drinking water, it is important to ensure that the quantities of the test substance involved do not interfere with normal nutrition or water balance. When the test substance is administered in the diet either a constant dietary concentration (ppm) or a constant dose level in terms of the body weight of the animal may be used; the alternative used must be specified. For a substance administered by gavage, the dose should be given at similar times each day, and adjusted at least weekly to maintain a constant dose level in terms of animal body weight. Information regarding placental distribution should be considered when adjusting the gavage dose based on weight.

#### 1.4.6 **Experimental schedules**

Daily dosing of the parental (P) males and females shall begin when they are 5 to 9 weeks old. Daily dosing of the F1 males and females shall begin at weaning; it should be kept in mind that in cases of test substance administration via diet or drinking water, direct exposure of the F1 pups to the test substance may already occur during the lactation period. For both sexes (P and F1), dosing shall be continued for at least 10 weeks before the mating period. Dosing is continued in both sexes during the 2 week mating period. Males should be humanely killed and examined when they are no longer needed for assessment of reproductive effects. For parental (P) females, dosing should continue throughout pregnancy and up to the

weaning of the F1 offspring. Consideration should be given to modifications in the dosing schedule based on available information on the test substance, including existing toxicity data, induction of metabolism or bioaccumulation. The dose to each animal should normally be based on the most recent individual body weight determination. However, caution should be exercised when adjusting the dose during the last trimester of pregnancy.

Treatment of the P and F1 males and females shall continue until termination. All P and F1 adult males and females should be humanely killed when they are no longer needed for assessment of reproductive effects. F1 offspring not selected for mating and all F2 offspring should be humanely killed after weaning.

#### 1.4.7 **Mating procedure**

##### 1.4.7.1 *Parental (P) mating*

For each mating, each female shall be placed with a single male from the same dose level (1:1 mating) until copulation occurs or 2 weeks have elapsed. Each day, the females shall be examined for presence of sperm or vaginal plugs. Day 0 of pregnancy is defined as the day a vaginal plug or sperm are found. In case pairing is unsuccessful, re-mating of females with proven males of the same group could be considered. Mating pairs should be clearly identified in the data. Mating of siblings should be avoided.

##### 1.4.7.2 *F1 mating*

For mating the F1 offspring, at least one male and one female should be selected at weaning from each litter for mating with other pups of the same dose level but different litter, to produce the F2 generation. Selection of pups from each litter should be random when no significant differences are observed in body weight or appearance between the litter mates. In case these differences are observed, the best representatives of each litter should be selected. Pragmatically, this is best done on a body weight basis but it may be more appropriate on the basis of appearance. The F1 offspring should not be mated until they have attained full sexual maturity.

Pairs without progeny should be evaluated to determine the apparent cause of the infertility. This may involve such procedures as additional opportunities to mate with other proven sires or dams, microscopic examination of the reproductive organs, and examination of the oestrous cycles or spermatogenesis.

##### 1.4.7.3 *Second mating*

In certain instances, such as treatment-related alterations in litter size or the observation of an equivocal effect in the first mating, it is recommended that the P or F1 adults be remated to produce a second litter. It is recommended to remate females or males, which have not produced a litter with proven breeders of the opposite sex. If production of a second litter is deemed necessary in either generation, animals should be remated approximately one week after weaning of the last litter.

##### 1.4.7.4 *Litter size*

Animals shall be allowed to litter normally and rear their offspring to weaning. Standardisation of litter sizes is optional. When standardisation is done, the method used should be described in detail.

#### 1.5 OBSERVATIONS

##### 1.5.1 **Clinical observations**

A general clinical observation should be made each day and, in the case of gavage dosing its timing should take into account the anticipated peak period of effects after dosing. Behavioural changes, signs of difficult or prolonged parturition and all signs of toxicity should be recorded. An additional, more detailed examination of each animal should be conducted on at least a weekly basis and could conveniently be performed on an occasion when the animal is weighed. Twice daily, during the weekend once daily when appropriate, all animals should be observed for morbidity and mortality.

### 1.5.2 **Body weight and food/water consumption of parent animals**

Parental animals (P and F1) shall be weighed on the first day of dosing and at least weekly thereafter. Parental females (P and F1) shall be weighed at a minimum on gestation days 0, 7, 14, and 20 or 21, and during lactation on the same days as the weighing of litters and on the day the animals are killed. These observations should be reported individually for each adult animal. During the pre-mating and gestation periods food consumption shall be measured weekly at a minimum. Water consumption shall be measured weekly at a minimum if the test substance is administered in the water.

### 1.5.3 **Oestrus cycle**

Estrous cycle length and normality are evaluated in P and F1 females by vaginal smears prior to mating, and optionally during mating, until evidence of mating is found. When obtaining vaginal/cervical cells, care should be taken to avoid disturbance of mucosa and subsequently, the induction of pseudopregnancy (1).

### 1.5.4 **Sperm parameters**

For all P and F1 males at termination, testis and epididymis weight shall be recorded and one of each organ reserved for histopathological examination (see section 1.5.7, 1.5.8.1). Of a subset of at least ten males of each group of P and F1 males, the remaining testes and epididymides should be used for enumeration of homogenisation-resistant spermatids and cauda epididymal sperm reserves, respectively. For this same subset of males, sperm from the cauda epididymides or vas deferens should be collected for evaluation of sperm motility and sperm morphology. If treatment-related effects are observed or when there is evidence from other studies of possible effects on spermatogenesis, sperm evaluation should be conducted in all males in each dose group; otherwise enumeration may be restricted to control and high-dose P and F1 males.

The total number of homogenisation-resistant testicular spermatids and cauda epididymal sperm should be enumerated (2)(3). Cauda sperm reserves can be derived from the concentration and volume of sperm in the suspension used to complete the qualitative evaluations, and the number of sperm recovered by subsequent mincing and/or homogenising of the remaining cauda tissue. Enumeration should be performed on the selected subset of males of all dose groups immediately after killing the animals unless video or digital recordings are made, or unless the specimens are frozen and analysed later. In these instances, the controls and high dose group may be analysed first. If no treatment-related effects (e.g., effects on sperm count, motility, or morphology) are seen the other dose groups need not be analysed. When treatment-related effects are noted in the high-dose group, then the lower dose groups should also be evaluated.

Epididymal (or ductus deferens) sperm motility should be evaluated or video taped immediately after sacrifice. Sperm should be recovered while minimising damage, and diluted for motility analysis using acceptable methods (4). The percentage of progressively motile sperm should be determined either subjectively or objectively. When computer-assisted motion analysis is performed (5)(6)(7)(8)(9)(10) the derivation of progressive motility relies on user-defined thresholds for average path velocity and straightness or linear index. If samples are videotaped (11) or the images are otherwise recorded at the time of necropsy, subsequent analysis of only control and high-dose P and F1 males may be performed unless treatment-related effects are observed; in that case, the lower dose groups should also be evaluated. In the absence of a video or digital image, all samples in all treatment groups should be analysed at necropsy.

A morphological evaluation of an epididymal (or vas deferens) sperm sample should be performed. Sperm (at least 200 per sample) should be examined as fixed, wet preparations (12) and classified as either normal or abnormal. Examples of morphologic sperm abnormalities would include fusion, isolated heads, and misshapen heads and/or tails. Evaluation should be performed on the selected subset of males of all dose groups either immediately after killing the animals, or, based on the video or digital recordings, at a

later time. Smears, once fixed, can also be read at a later time. In these instances, the controls and high dose group may be analysed first. If no treatment-related effects (e.g., effects on sperm morphology) are seen the other dose groups need not be analysed. When treatment-related effects are noted in the high-dose group, then the lower dose groups should also be evaluated.

If any of the above sperm evaluation parameters have already been examined as part of a systemic toxicity study of at least 90 days, they need not necessarily be repeated in the two-generation study. It is recommended, however, that samples or digital recordings of sperm of the P generation are saved, to enable later evaluation, if necessary.

#### 1.5.5 **Offspring**

Each litter should be examined as soon as possible after delivery (lactation day 0) to establish the number and sex of pups, stillbirths, live births, and the presence of gross anomalies. Pups found dead on day 0, if not macerated, should preferably be examined for possible defects and cause of death and preserved. Live pups should be counted and weighed individually at birth (lactation day 0) or on day 1, and on regular weigh days thereafter, e.g., on days 4, 7, 14, and 21 of lactation. Physical or behavioural abnormalities observed in the dams or offspring should be recorded.

Physical development of the offspring should be recorded mainly by body weight gain. Other physical parameters (e.g. ear and eye opening, tooth eruption, hair growth) may give supplementary information, but these data should preferably be evaluated in the context of data on sexual maturation (e.g. age and body weight at vaginal opening or balano-preputial separation) (13). Functional investigations (e.g. motor activity, sensory function, reflex ontogeny) of the F1 offspring before and/or after weaning, particularly those related to sexual maturation, are recommended if such investigations are not included in separate studies. The age of vaginal opening and preputial separation should be determined for F1 weanlings selected for mating. Anogenital distance should be measured at postnatal day 0 in F2 pups if triggered by alterations in F1 sex ratio or timing of sexual maturation.

Functional observations may be omitted in groups that otherwise reveal clear signs of adverse effects (e.g., significant decrease in weight gain, etc.). If functional investigations are made, they should not be done on pups selected for mating.

#### 1.5.6 **Gross necropsy**

At the time of termination or death during the study, all parental animals (P and F1), all pups with external abnormalities or clinical signs, as well as one randomly selected pup/sex/litter from both the F1 and F2 generation, shall be examined macroscopically for any structural abnormalities or pathological changes. Special attention should be paid to the organs of the reproductive system. Pups that are humanely killed in a moribund condition and dead pups, when not macerated, should be examined for possible defects and/or cause of death and preserved.

The uteri of all primiparous females should be examined, in a manner which does not compromise histopathological evaluation, for the presence and number of implantation sites.

#### 1.5.7 **Organ weights**

At the time of termination, body weight and the weight of the following organs of all P and F1 parental animals shall be determined (paired organs should be weighed individually):

- Uterus, ovaries;
- Testes, epididymides (total and cauda);
- Prostate;

- Seminal vesicles with coagulating glands and their fluids and prostate (as one unit);
- Brain, liver, kidneys, spleen, pituitary, thyroid and adrenal glands and known target organs.

Terminal body weights should be determined for F1 and F2 pups that are selected for necropsy. The following organs from the one randomly selected pup/sex/litter (see section 1.5.6) shall be weighed: Brain, spleen and thymus.

Gross necropsy and organ weight results should be assessed in context with observations made in other repeated dose studies, when feasible.

## 1.5.8 Histopathology

### 1.5.8.1 Parental Animals

The following organs and tissues of parental (P and F1) animals, or representative samples thereof, shall be fixed and stored in a suitable medium for histopathological examination.

- Vagina, uterus with cervix, and ovaries (preserved in appropriate fixative);
- One testis (preserved in Bouin's or comparable fixative), one epididymis, seminal vesicles, prostate, and coagulating gland;
- Previously identified target organ(s) from all P and F1 animals selected for mating.

Full histopathology of the preserved organs and tissues listed above should be performed for all high dose and control P and F1 animals selected for mating. Examination of the ovaries of the P animals is optional. Organs demonstrating treatment-related changes should also be examined in the low- and mid-dose groups to aid in the elucidation of the NOAEL. Additionally, reproductive organs of the low- and mid-dose animals suspected of reduced fertility, e.g., those that failed to mate, conceive, sire, or deliver healthy offspring, or for which oestrus cyclicity or sperm number, motility, or morphology were affected, should be subjected to histopathological evaluation. All gross lesions such as atrophy or tumours shall be examined.

Detailed testicular histopathological examination (e.g. using Bouin's fixative, paraffin embedding and transverse sections of 4-5 µm thickness) should be conducted in order to identify treatment-related effects such as retained spermatids, missing germ cell layers or types, multinucleated giant cells or sloughing of spermatogenic cells into the lumen (14). Examination of the intact epididymis should include the caput, corpus, and cauda, which can be accomplished by evaluation of a longitudinal section. The epididymis should be evaluated for leukocyte infiltration, change in prevalence of cell types, aberrant cell types, and phagocytosis of sperm. PAS and haematoxylin staining may be used for examination of the male reproductive organs.

The postlactational ovary should contain primordial and growing follicles as well as the large corpora lutea of lactation. Histopathological examination should detect qualitative depletion of the primordial follicle population. A quantitative evaluation of primordial follicles should be conducted for F1 females; the number of animals, ovarian section selection, and section sample size should be statistically appropriate for the evaluation procedure used. Examination should include enumeration of the number of primordial follicles, which can be combined with small growing follicles, for comparison of treated and control ovaries (15) (16) (17) (18) (19).

### 1.5.8.2 Weanlings

Grossly abnormal tissue and target organs from all pups with external abnormalities or clinical signs, as well as from the one randomly selected pup/sex/litter from both the F1 and F2 generation which have not been selected for mating, shall be fixed and stored in a suitable medium for histopathological examination. Full histopathological characterisation of preserved tissue should be performed with special emphasis on the organs of the reproductive system.

## 2. DATA

### 2.1 TREATMENT OF RESULTS

Data shall be reported individually and summarised in tabular form, showing for each test group and each generation the number of animals at the start of the test, the number of animals found dead during the test or killed for humane reasons, the time of any death or humane kill, the number of fertile animals, the number of pregnant females, the number of animals showing signs of toxicity, a description of the signs of toxicity observed, including time of onset, duration, and severity of any toxic effects, the types of parental and offspring observations, the types of histopathological changes, and all relevant litter data.

Numerical results should be evaluated by an appropriate, generally accepted statistical method; the statistical methods should be selected as part of the design of the study and should be justified. Dose-response statistical models may be useful for analysing data. The report should include sufficient information on the method of analysis and the computer program employed, so that an independent reviewer/statistician can re-evaluate and reconstruct the analysis.

### 2.2 EVALUATION OF RESULTS

The findings of this two-generation reproduction toxicity study should be evaluated in terms of the observed effects including necropsy and microscopic findings. The evaluation will include the relationship, or lack thereof, between the dose of the test substance and the presence or absence, incidence and severity of abnormalities, including gross lesions, identified target organs, affected fertility, clinical abnormalities, affected reproductive and litter performance, body weight changes, effects on mortality and any other toxic effects. The physico-chemical properties of the test substance, and when available, toxicokinetics data should be taken into consideration when evaluating test results.

A properly conducted reproduction toxicity test should provide a satisfactory estimation of a no-effect level and an understanding of adverse effects on reproduction, parturition, lactation, postnatal development including growth and sexual development.

### 2.3 INTERPRETATION OF RESULTS

A two-generation reproduction toxicity study will provide information on the effects of repeated exposure to a substance during all phases of the reproductive cycle. In particular, the study provides information on the reproductive parameters, and on development, growth, maturation and survival of offspring. The results of the study should be interpreted in conjunction with the findings from subchronic, prenatal developmental and toxicokinetic and other available studies. The results of this study can be used in assessing the need for further testing of a chemical. Extrapolation of the results of the study to man is valid to a limited degree. They are best used to provide information on no-effect-levels and permissible human exposure (20) (21) (22) (23).

## 3. REPORTING

### 3.1 TEST REPORT

The test report must include the following information:

Test substance:

- physical nature and, where relevant, physicochemical properties;
- identification data;
- purity.

Vehicle (if appropriate):

- justification for choice of vehicle if other than water.



## Test animals:

- species/strain used;
- number, age and sex of animals;
- source, housing conditions, diet, nesting materials, etc.;
- individual weights of animals at the start of the test.

## Test conditions:

- rationale for dose level selection;
- details of test substance formulation/diet preparation, achieved concentrations;
- stability and homogeneity of the preparation;
- details of the administration of the test substance;
- conversion from diet/drinking water test substance concentration (ppm) to the achieved dose (mg/kg body weight/day), if applicable;
- details of food and water quality.

## Results:

- food consumption, and water consumption if available, food efficiency (body weight gain per gram of food consumed), and test material consumption for P and F1 animals, except for the period of cohabitation and for at least the last third of lactation;
- absorption data (if available);
- body weight data for P and F1 animals selected for mating;
- litter and pup weight data;
- body weight at sacrifice and absolute and relative organ weight data for the parental animals;
- nature, severity and duration of clinical observations (whether reversible or not);
- time of death during the study or whether animals survived to termination;
- toxic response data by sex and dose, including indices of mating, fertility, gestation, birth, viability, and lactation; the report should indicate the numbers used in calculating these indices;
- toxic or other effects on reproduction, offspring, post-natal growth, etc.;
- necropsy findings;
- detailed description of all histopathological findings;
- number of P and F1 females cycling normally and cycle length;
- total cauda epididymal sperm number, percent progressively motile sperm, percent morphologically normal sperm, and percent of sperm with each identified abnormality;
- time-to-mating, including the number of days until mating ;
- gestation length;

- number of implantations, corpora lutea, litter size;
- number of live births and post-implantation loss;
- number of pups with grossly visible abnormalities, if determined the number of runts should be reported;
- data on physical landmarks in pups and other post natal developmental data; physical landmarks evaluated should be justified;
- data on functional observations in pups and adults, as applicable;
- statistical treatment of results, where appropriate.

Discussion of results.

Conclusions, including NOAEL values for maternal and offspring effects.

#### 4.

#### REFERENCES

- (1) Sadleir, R.M.F.S. (1979). Cycles and Seasons, In: *Reproduction in Mammals: I. Germ Cells and Fertilization*, C.R. Auston and R.V. Short (eds.), Cambridge, New York.
- (2) Gray, L.E. et al., (1989). A Dose-Response Analysis of Methoxychlor-Induced Alterations of Reproductive Development and Function in the Rat. *Fundamental and Applied Toxicology* 12:92-108.
- (3) Robb, G.W. et al., (1978). Daily Sperm Production and Epididymal Sperm Reserves of Pubertal and Adult Rats. *Journal of Reproduction and Fertility* 54:103-107.
- (4) Klinefelter, G.R. et al., (1991). The Method of Sperm Collection Significantly Influences Sperm Motion Parameters Following Ethane Dimethanesulfonate Administration in the Rat. *Reproductive Toxicology* 5:39-44
- (5) Seed, J. et al. (1996). Methods for Assessing Sperm Motility, Morphology, and Counts in the Rat, Rabbit, and Dog: a Consensus Report. *Reproductive Toxicology* 10(3):237-244.
- (6) Chapin, R.E. et al., (1992). Methods for Assessing Rat Sperm Motility. *Reproductive Toxicology* 6:267-273
- (7) Klinefelter, G.R. et al., (1992). Direct Effects of Ethane Dimethanesulphonate on Epididymal Function in Adult Rats: an *In Vitro* Demonstration. *Journal of Andrology* 13:409-421.
- (8) Slott, V.L. et al., (1991). Rat Sperm Motility Analysis: Methodologic Considerations. *Reproductive Toxicology* 5:449-458.
- (9) Slott, V.L. and Perreault, S.D., (1993). Computer-Assisted Sperm Analysis of Rodent Epididymal Sperm Motility Using the Hamilton-Thorn Motility Analyzer. In: *Methods in Toxicology, Part A*, Academic, Orlando, Florida. pp. 319-333.
- (10) Toth, G.P. et al. (1989). The Automated Analysis of Rat Sperm Motility Following Subchronic Epichlorhydrin Administration: Methodologic and Statistical Considerations. *Journal of Andrology* 10: 401-415.
- (11) Working, P.K. and M. Hurtt, (1987). Computerized Videomicrographic Analysis of Rat Sperm Motility. *Journal of Andrology* 8:330-337.
- (12) Linder, R.E. et al., (1992). Endpoints of Spermatotoxicity in the Rat After Short Duration Exposures to Fourteen Reproductive Toxicants. *Reproductive Toxicology* 6:491-505.
- (13) Korenbrot, C.C. et al., (1977). Preputial Separation as an External Sign of Pubertal Development in the Male Rat. *Biological Reproduction* 17:298-303.
- (14) Russell, L.D. et al., (1990). *Histological and Histopathological Evaluation of the Testis*, Cache River Press, Clearwater, Florida.

- (15) Heindel, J.J. and R.E. Chapin, (eds.) (1993). Part B. Female Reproductive Systems, Methods in Toxicology, Academic, Orlando, Florida.
  - (16) Heindel, J.J. et al., (1989) Histological Assessment of Ovarian Follicle Number in Mice As a Screen of Ovarian Toxicity. In: Growth Factors and the Ovary, A.N. Hirshfield (ed.), Plenum, New York, pp. 421-426.
  - (17) Manson, J.M. and Y.J. Kang, (1989). Test Methods for Assessing Female Reproductive and Developmental Toxicology. In: Principles and Methods of Toxicology, A.W. Hayes (ed.), Raven, New York.
  - (18) Smith, B.J. et al., (1991). Comparison of Random and Serial Sections in Assessment of Ovarian Toxicity. *Reproductive Toxicology* 5:379-383.
  - (19) Heindel, J.J. (1999). Oocyte Quantitation and Ovarian Histology. In: An Evaluation and Interpretation of Reproductive Endpoints for Human Health Risk Assessment, G. Daston, and C.A. Kimmel, (eds.), ILSI Press, Washington, DC.
  - (20) Thomas, J. A. (1991). Toxic Responses of the Reproductive System. In: Casarett and Doull's Toxicology, M.O. Amdur, J. Doull, and C.D. Klaassen (eds.), Pergamon, New York.
  - (21) Zenick, H. and E.D. Clegg, (1989). Assessment of Male Reproductive Toxicity: A Risk Assessment Approach. In: Principles and Methods of Toxicology, A.W. Hayes (ed.), Raven Press, New York.
  - (22) Palmer, A.K. (1981). In: Developmental Toxicology, Kimmel, C.A. and J. Buelke-Sam (eds.), Raven Press, New York.
  - (23) Palmer, A.K. (1978). In Handbook of Teratology, Vol. 4, J.G. Wilson and F.C. Fraser (eds.), Plenum Press, New York.
-

## ANNEX 2H

**B.42. SKIN SENSITISATION: LOCAL LYMPH NODE ASSAY****1. METHOD**

This test method is equivalent to the OECD TG 429 (2002)

**1.1 INTRODUCTION**

The Local Lymph Node Assay (LLNA) has been sufficiently validated and accepted to justify its adoption as a new Method (1)(2)(3). This is the second method for assessing skin sensitisation potential of chemicals in animals. The other method (B.6) utilises guinea pig tests, notably the guinea pig maximisation test and the Buehler test (4).

The LLNA provides an alternative method for identifying skin sensitising chemicals and for confirming that chemicals lack a significant potential to cause skin sensitisation. This does not necessarily imply that in all instances the LLNA should be used in place of guinea pig test, but rather that the assay is of equal merit and may be employed as an alternative in which positive and negative results generally no longer require further confirmation.

The LLNA provides certain advantages with regard to both scientific progress and animal welfare. It studies the induction phase of skin sensitisation and provides quantitative data suitable for dose response assessment. The details of the validation of the LLNA and a review of the associated work have been published (5)(6)(7)(8). In addition, it should be noted that the mild/moderate sensitisers, which are recommended as suitable positive control substances for guinea pig test methods, are also appropriate for use with the LLNA (6)(8)(9).

The LLNA is an *in vivo* method and, as a consequence, will not eliminate the use of animals in the assessment of contact sensitising activity. It has, however, the potential to reduce the number of animals required for this purpose. Moreover, the LLNA offers a substantial refinement of the way in which animals are used for contact sensitisation testing. The LLNA is based upon consideration of immunological events stimulated by chemicals during the induction phase of sensitisation. Unlike guinea pig tests the LLNA does not require that challenged-induced dermal hypersensitivity reactions be elicited. Furthermore, the LLNA does not require the use of an adjuvant, as is the case for the guinea pig maximisation test. Thus, the LLNA reduces animal distress. Despite the advantages of the LLNA over traditional guinea pig tests, it should be recognised that there are certain limitations that may necessitate the use of traditional guinea pigs tests (e.g., false negative findings in the LLNA with certain metals, false positive findings with certain skin irritants)(10).

See also Introduction part B.

**1.2 PRINCIPLE OF THE TEST METHOD**

The basic principle underlying the LLNA is that sensitisers induce a primary proliferation of lymphocytes in the lymph node draining the site of chemical application. This proliferation is proportional to the dose applied (and to the potency of the allergen) and provides a simple means of obtaining an objective, quantitative measurement of sensitisation. The LLNA assesses this proliferation as a dose-response relationship in which the proliferation in test groups is compared to that in vehicle treated controls. The ratio of the proliferation in treated groups to that in vehicular controls, termed the Stimulation Index, is determined, and must be at least three before a test substance can be further evaluated as a potential skin sensitiser. The methods described here are based on the use of radioactive labelling to measure cell proliferation. However, other endpoints for assessment of proliferation may be employed provided there is justification and appropriate scientific support, including full citations and description of the methodology.

### 1.3 DESCRIPTION OF THE TEST METHOD

#### 1.3.1 Preparations

##### 1.3.1.1 *Housing and feeding conditions*

Animals should be individually housed. The temperature of the experimental animals room should be 22°C ( $\pm 3^\circ\text{C}$ ). Although the relative humidity should be at least 30 % and preferably not exceed 70 % other than during room cleaning, the aim should be 50-60 %. Lighting should be artificial, the sequence being 12 hours light, 12 hours dark. For feeding, conventional laboratory diets may be used with an unlimited supply of drinking water.

##### 1.3.1.2 *Preparation of animals*

The animals are randomly selected, marked to permit individual identification (but not by any form of ear marking), and kept in their cages for at least 5 days prior to the start of dosing to allow for acclimatisation to the laboratory conditions. Prior to the start of treatment all animals are examined to ensure that they have no observable skin lesions.

#### 1.3.2 Test Conditions

##### 1.3.2.1 *Experimental animals*

The mouse is the species of choice for this test. Young adult female mice of CBA/Ca or CBA/J strain, which are nulliparous and non-pregnant are used. At the start of the study, animals should be between 8-12 weeks old, and the weight variation of the animals should be minimal and not exceed 20 % of the mean weight. Other strains and males may be used when sufficient data are generated to demonstrate that significant strain and/or gender-specific differences in the LLNA response do not exist.

##### 1.3.2.2 *Reliability check*

Positive controls are used to demonstrate appropriate performance of the assay and competency of the laboratory to successfully conduct the assay. The positive control should produce a positive LLNA response at an exposure level expected to give an increase in the stimulation index (SI)  $>3$  over the negative control group. The positive control dose should be chosen such that the induction is clear but not excessive. Preferred substances are hexyl cinnamic aldehyde (CAS No 101-86-0, EINECS No 202-983-3) and mercaptobenzothiazole (CAS No 149-30-4, EINECS No 205-736-8). There may be circumstances in which, given adequate justification, other control substances, meeting the above criteria, may be used. While ordinarily a positive control group may be required in each assay, there may be situations in which test laboratories will have available historic positive control data to show consistency of a satisfactory response over a six-month or more extended period. In those situations, less frequent testing with positive controls may be appropriate at intervals no greater than 6 months. Although the positive control substance should be tested in the vehicle that is known to elicit a consistent response (e.g., acetone: olive oil), there may be certain regulatory situations in which testing in non-standard vehicle (clinically/chemically relevant formulation) will also be necessary. In such situation the possible interaction of a positive control with this unconventional vehicle should be tested.

##### 1.3.2.3 *Number of animals, dose levels and vehicle selection.*

A minimum of four animals is used per dose group, with a minimum of three concentrations of the test substance, plus a negative control group treated only with the vehicle for the test substance, and, as appropriate, a positive control. In those cases in which individual animal data are to be collected, a minimum of five animals per dose group are used. Except for absence of treatment with the test substance, animals in the control groups should be handled and treated in a manner identical to that of animals in the treatment groups.

Dose and vehicle selection should be based on the recommendations given in reference (1). Doses are selected from the concentration series 100 %, 50 %, 25 %, 10 %, 5 %, 2.5 %, 1 %, 0.5 % etc. Existing acute toxicity and dermal irritation data should be considered, where available, in selecting the three consecutive concentrations so that the highest concentration maximises exposure whilst avoiding systemic toxicity and excessive local skin irritation (2)(11).

The vehicle should be selected on the basis of maximising the test concentrations and solubility whilst producing a solution/suspension suitable for application of the test substance. In order of preference, recommended vehicles are acetone/olive oil (4:1 v/v), dimethylformamide, methyl ethyl ketone, propylene glycol and dimethyl sulphoxide (2)(10), but others may be used if sufficient scientific rationale is provided. In certain situations it may be necessary to use a clinically relevant solvent or the commercial formulation in which the test substance is marketed as an additional control. Particular care should be taken to ensure that hydrophilic materials are incorporated into a vehicle system, which wets the skin and does not immediately run off. Thus, wholly aqueous vehicles are to be avoided.

### 1.3.3 Test procedure

#### 1.3.3.1 Experimental schedule

The experimental schedule of the assay is as follows:

- *Day 1:*

Individually identify and record the weight of each animal. Open application of 25µl of the appropriate dilution of the test substance, the vehicle alone, or the positive control (as appropriate), to the dorsum of each ear.

- *Days 2 and 3:*

Repeat the application procedure carried out on day 1.

- *Days 4 and 5*

No treatment.

- *Day 6*

Record the weight of each animal. Inject 250µl of phosphate-buffered saline (PBS) containing 20 µCi (7.4e + 8 Bq) of <sup>3</sup>H-methyl thymidine into all test and control mice via the tail vein. Alternatively inject 250 µL PBS containing 2 µCi (7.4e + 7 Bq) of <sup>125</sup>I-iododeoxyuridine and 10<sup>-5</sup> M fluorodeoxyuridine into all mice via the tail vein.

Five hours later, the animals are killed. The draining auricular lymph nodes from each ear are excised and pooled in PBS for each experimental group (pooled treatment group approach); alternatively pairs of lymph nodes from individual animals may be excised and pooled in PBS for each animal (individual animal approach). Details and diagrams of the node identification and dissection can be found in Annex I of reference 10.

#### 1.3.3.2 Preparation of cell suspensions

A single cell suspension of lymph node cells (LNC) either from pooled treatment groups or bilaterally from individual animals is prepared by gentle mechanical disaggregation through 200 µm-mesh stainless steel gauze. Lymph node cells are washed twice with an excess of PBS and precipitated with 5 % trichloroacetic acid (TCA) at 4 °C for 18h (2). Pellets are either re-suspended in 1 ml TCA and transferred to scintillation vials containing 10 ml of scintillation fluid for <sup>3</sup>H-counting, or transferred directly to gamma counting tubes for <sup>125</sup>I-counting.

#### 1.3.3.3 Determination of cell proliferation (incorporated radioactivity)

Incorporation of <sup>3</sup>H-methyl thymidine is measured by β-scintillation counting as disintegrations per minute (DPM). Incorporation of <sup>125</sup>I-iododeoxyuridine is measured by <sup>125</sup>I-counting and also is expressed as DPM. Depending on the approach used, the incorporation will be expressed as DPM/treatment group (pooled approach) or the DPM/animal (individual approach).

1.3.3.4 *Observations*

1.3.3.4.1 *Clinical observations*

Animals should be carefully observed once daily for any clinical signs, either of local irritation at the application site or of systemic toxicity. All observations are systematically recorded with individual records being maintained for each animal.

1.3.3.4.2 *Body Weights*

As stated in section 1.3.3.1, individual animal body weights should be measured at the start of the test and at the scheduled kill of the animals.

1.3.4 **Calculation of results**

Results are expressed as the Stimulation Index (SI). When using the pooled approach, the SI is obtained by dividing the pooled radioactive incorporation for each treatment group by the incorporation of the pooled vehicle control group; this yields a mean SI. When using the individual approach, the SI is derived by dividing the mean DPM/animal within each test substance group and the positive control group by the mean DPM/animal for the solvent/vehicle control group. The average SI for vehicle treated controls is then 1.

Use of the individual approach to calculate the SI will enable the performance of a statistical analysis of the data. In choosing an appropriate method of statistical analysis the investigator should maintain an awareness of possible inequalities of variances and other related problems that may necessitate a data transformation or a non-parametric statistical analysis. An adequate approach for interpreting the data is to evaluate all individual data of treated and vehicle controls, and derive from these the best fitting dose response curve, taking confidence limits into account (8)(12)(13). However, the investigator should be alert to possible "outlier," responses for individual animals within a group that may necessitate the use of an alternative measure of response (e.g., median rather than mean) or elimination of the outlier.

The decision process with regard to a positive response includes a stimulation index  $\geq 3$  together with consideration of dose-response and, where appropriate, statistical significance (3)(6)(8)(12)(14).

If it is necessary to clarify the results obtained, consideration should be given to various properties of the test substance, including whether it has a structural relationship to known skin sensitizers, whether it causes excessive skin irritation and the nature of the dose response seen. These and other considerations are discussed in detail elsewhere (7).

2. **DATA**

Data should be summarised in tabular form showing the mean and individual DPM values and stimulation indexes for each dose (including vehicle control) group.

3. **REPORTING**

3.1 TEST REPORT

The test report should contain the following information:

Test substance:

- identification data (e.g., CAS number, if available; source; purity; known impurities; lotnumber);
- physical nature and physicochemical properties (e.g., volatility, stability, solubility);
- if mixture, composition and relative percentages of components.

## Vehicle:

- identification data [purity; concentration (where appropriate); volume used]
- justification for choice of vehicle.

## Test animals:

- strain of mice used;
- microbiological status of the animals, when known;
- source of animals, housing conditions, diet, etc.
- number, age and sex of animals;

## Test conditions:

- details of test substance preparation and application;
- justification for dose selection, including results from range finding study, if conducted; vehicle and test substance concentrations used and the total amount of substance applied
- details of food and water quality (including diet type/source, water source).

## Reliability check:

- a summary of the results of the latest reliability check including information on substance, concentration and vehicle used.
- concurrent and/or historical positive and negative control data for testing laboratory

## Results:

- individual weights of animals at the start of dosing and at scheduled kill.
- a table of mean (pooled approach) and individual (individual approach) DPM values as well as the range of values for both approaches and the stimulation indices for each dose (including vehicle control) group.
- statistical analysis where appropriate
- time course of onset and signs of toxicity, including dermal irritation at site of administration, if any, for each animal.

## Discussion of results:

- A brief commentary on the results, the dose-response analysis, and statistical analyses, where appropriate, with a conclusion as to whether the test substance should be considered a skin sensitiser.

**4. REFERENCES**

- (1) Kimber, I. and Basketter, D.A. (1992). The murine local lymph node assay; collaborative studies and new directions: A commentary. *Food and Chemical Toxicology* 30, 165-169.
- (2) Kimber, I, Derman, R.J., Scholes E.W, and Basketter, D.A. (1994). The local lymph node assay: developments and applications. *Toxicology*, 93, 13-31.



- (3) Kimber, I., Hilton, J., Dearman, R.J., Gerberick, G.F., Ryan, C.A., Basketter, D.A., Lea, L., House, R.V., Ladies, G.S., Loveless, S.E., Hastings, K.L. (1998). Assessment of the skin sensitisation potential of topical medicaments using the local lymph node assay: An interlaboratory exercise. *Journal of Toxicology and Environmental Health*, 53, 563-79.
- (4) Testing Method B.6.
- (5) Chamberlain, M. and Basketter, D.A. (1996). The local lymph node assay: status of validation. *Food and Chemical Toxicology*, 34, 999-1002.
- (6) Basketter, D.A., Gerberick, G.F., Kimber, I. and Loveless, S.E (1996). The local lymph node assay- A viable alternative to currently accepted skin sensitisation tests. *Food and Chemical Toxicology*, 34, 985-997.
- (7) Basketter, D.A., Gerberick, G.F. and Kimber, I. (1998). Strategies for identifying false positive responses in predictive sensitisation tests. *Food and Chemical Toxicology*. 36, 327-33.
- (8) Van Och, F.M.M, Slob, W., De Jong, W.H., Vandebriel, R.J., Van Loveren, H. (2000). A quantitative method for assessing the sensitising potency of low molecular weight chemicals using a local lymph node assay: employment of a regression method that includes determination of uncertainty margins. *Toxicology*, 146, 49-59.
- (9) Dearman, R.J., Hilton, J., Evans, P., Harvey, P., Basketter, D.A. and Kimber, I. (1998). Temporal stability of local lymph node assay responses to hexyl cinnamic aldehyde. *Journal of Applied Toxicology*, 18, 281-4.
- (10) National Institute of Environmental Health Sciences (1999). The Murine Local Lymph Node Assay: A Test Method for Assessing the Allergic Contact Dermatitis Potential of Chemicals/Compounds: The Results of an Independent Peer Review Evaluation Coordinated by the Interagency Coordinating Committee on the Validation of Alternative Methods (ICCVAM) and the National Toxicology Program Center for the Evaluation of Alternative Toxicological Methods (NICETAM). NIH Publication No: 99-4494, Research Triangle Park, N.C. (<http://iccvam.niehs.nih.gov>).
- (11) Testing method B.4.
- (12) Basketter, D.A., Selbie, E., Scholes, E.W. Lees, D. Kimber, I. and Botham, P.A. (1993) Results with OECD recommended positive control sensitisers in the maximisation, Buehler and local lymph node assays. *Food and Chemical Toxicology*, 31, 63-67.
- (13) Basketter D.A., Lea L.J., Dickens A., Briggs D., Pate I., Dearman R.J., Kimber I. (1999). A comparison of statistical approaches to the derivation of EC<sub>3</sub> values from local lymph node assay dose responses. *J. Appl. Toxicology*, 19, 261-266.
- (14) Basketter DA, Blaikie L, Derman RJ, Kimber I, Ryan CA, Gerberick GF, Harvey P, Evans P, White IR and Rycroft RTG (2000). Use of local lymph node assay for the estimation of relative contact allergenic potency. *Contact Dermatitis* 42, 344-48.

**B.43. NEUROTOXICITY STUDY IN RODENTS****1. METHOD**

This method is equivalent of OECD TG 424 (1997).

This Test Method has been designed to obtain the information necessary to confirm or to further characterise the potential neurotoxicity of chemicals in adult animals. It can either be combined with existing Test Methods for repeated dose toxicity studies or to be carried out as a separate study. It is recommended that the OECD Guidance Document on Neurotoxicity Testing Strategies and Methods (1) be consulted to assist in the design of studies based on this Test Method. This is particularly important when modifications of the observations and test procedures as recommended for routine use of this Method are considered. The Guidance Document has been prepared to facilitate the selection of other test procedures for use in specific circumstances. The assessment of developmental neurotoxicity is not the subject of this Method.

**1.1 INTRODUCTION**

In the assessment and evaluation of the toxic characteristics of chemicals, it is important to consider the potential for neurotoxic effects. Already the Test Method for repeated dose systemic toxicity includes observations that screen for potential neurotoxicity. This Test Method can be used to design a study to obtain further information on, or to confirm, the neurotoxic effects observed in the repeated dose systemic toxicity studies. However, consideration of the potential neurotoxicity of certain classes of chemicals may suggest that they may be more appropriately evaluated using this Method without prior indications of the potential neurotoxicity from repeated dose systemic toxicity studies. Such considerations include, for example:

- observation of neurological signs or neuropathological lesions in toxicity studies other than repeated dose systemic toxicity studies, or
- structural relationship or other information linking them to known neurotoxicants.

In addition there may be other instances when use of this Test Method is appropriate; for further details see (1).

This Method has been developed so that it can be tailored to meet particular needs to confirm the specific histopathological and behavioural neurotoxicity of a chemical as well as provide a characterization and quantification of the neurotoxic responses.

In the past, neurotoxicity was equated with neuropathy involving neuropathological lesions or neurological dysfunctions, such as seizure, paralysis or tremor. Although neuropathy is an important manifestation of neurotoxicity, it is now clear that there are many other signs of nervous system toxicity (e.g. loss of motor co-ordination, sensory deficits, learning and memory dysfunctions) that may not be reflected in neuropathy or other types of studies.

This neurotoxicity Test Method is designed to detect major neurobehavioural and neuropathological effects in adult rodents. While behavioural effects, even in the absence of morphological changes, can reflect an adverse impact on the organism, not all behavioural changes are specific to the nervous system. Therefore, any changes observed should be evaluated in conjunction with correlative histopathological, haematological or biochemical data as well as data on other types of systemic toxicity. The testing called for in this Method to provide a characterization and quantification of the neurotoxic responses includes specific histopathological and behavioural procedures that may be further supported by electrophysiological and/or biochemical investigations (1)(2)(3)(4).

Neurotoxicants may act on a number of targets within the nervous system and by a variety of mechanisms. Since no single array of tests is capable of thoroughly assessing the neurotoxic potential of all substances, it may be necessary to utilize other *in vivo* or *in vitro* tests specific to the type of neurotoxicity observed or anticipated.

This Test Method can also be used, in conjunction with the guidance set out in the OECD Guidance Document on Neurotoxicity Testing Strategies and Methods (1) to design studies intended to further characterize or increase the sensitivity of the dose-response quantification in order to better estimate a no-observed-adverse effect level or to substantiate known or suspected hazards of the chemical. For example, studies may be designed to identify and evaluate the neurotoxic mechanism(s) or supplement the data

already available from the use of basic neurobehavioural and neuropathological observation procedures. Such studies need not replicate data that would be generated from the use of the standard procedures recommended in this Method, if such data are already available and are not considered necessary for the interpretation of the results of the study.

This neurotoxicity study, when used alone or in combination, provides information that can:

- identify whether the nervous system is permanently or reversibly affected by the chemical tested;
- contribute to the characterization of the nervous system alterations associated with exposure to the chemical, and to understanding the underlying mechanism.
- determine dose-and time-response relationships in order to estimate a no-observed-adverse-effect level (which can be used to establish safety criteria for the chemical).

This Test Method uses oral administration of the test substance. Other routes of administration (e.g. dermal or inhalation) may be more appropriate, and may require modification of the procedures recommended. Considerations of the choice of the route of administration depend on the human exposure profile and available toxicological or kinetic information.

## 1.2 DEFINITIONS

**Adverse effect:** is any treatment-related alteration from baseline that diminishes an organism's ability to survive, reproduce or adapt to the environment.

**Dose:** is the amount of test substance administered. Dose is expressed as weight (g, mg) or as weight of test substance per unit weight of the test animal (e.g. mg/Kg), or as constant dietary concentrations (ppm).

**Dosage:** is a general term comprising of dose, its frequency and the duration of dosing.

**Neurotoxicity:** is an adverse change in the structure or function of the nervous system that results from exposure to a chemical, biological or physical agent.

**Neurotoxicant:** is any chemical, biological or physical agent having the potential to cause neurotoxicity.

**NOAEL:** is the abbreviation for no-observed-adverse effect level and is the highest dose level where no adverse treatment-related findings are observed.

## 1.3 PRINCIPLE OF THE TEST METHOD

The test chemical is administered by the oral route across a range of doses to several groups of laboratory rodents. Repeated doses are normally required, and the dosing regimen may be 28 days, subchronic (90 days) or chronic (1 year or longer). The procedures set out in this Test Method may also be used for an acute neurotoxicity study. The animals are tested to allow the detection or the characterization of behavioural and/or neurological abnormalities. A range of behaviours that could be affected by neurotoxicants is assessed during each observation period. At the end of the test, a subset of animals of each sex from each group are perfused *in situ* and sections of the brain, spinal cord, and peripheral nerves are prepared and examined.

When the study is conducted as a stand-alone study to screen for neurotoxicity or to characterize neurotoxic effects, the animals in each group not used for perfusion and subsequent histopathology (see Table 1) can be used for specific neurobehavioural, neuropathological, neurochemical or electrophysiological procedures that may supplement the data obtained from the standard examinations required by this Method (1). These supplemental procedures can be particularly useful when empirical observations or anticipated effects indicate a specific type or target of a chemical's neurotoxicity. Alternatively, the remaining animals can be used for evaluations such as those called for in Test Methods for repeated dose toxicity studies in rodents.

When the procedures of this Test Method are combined with those of other Test Methods, a sufficient number of animals is needed to satisfy the requirements for the observations of both studies.

#### 1.4 DESCRIPTION OF THE TEST METHOD

##### 1.4.1 Selection of animal species

The preferred rodent species is the rat, although other rodent species, with justification, may be used. Commonly used laboratory strains of young adult healthy animals should be employed. The females should be nulliparous and non-pregnant. Dosing should normally begin as soon as possible after weaning, preferably not later than when animals are six weeks, and, in any case, before the animals are nine weeks age. However, when this study is combined with other studies this age requirement may need adjustment. At the commencement of the study the weight variation of animals used should not exceed  $\pm 20\%$  of the mean weight of each sex. Where a repeated dose study of short duration is conducted as a preliminary to a long term study, animals from the same strain and source should be used in both studies.

##### 1.4.2 Housing and feeding conditions

The temperature in the experimental animal room should be  $22\text{ }^{\circ}\text{C}$  ( $\pm 3\text{ }^{\circ}\text{C}$ ). Although the relative humidity should be at least  $30\%$  and preferably not exceed  $70\%$  other than during room cleaning, the aim should be  $50\text{-}60\%$ . Lighting should be artificial, the sequence being 12 hours light, 12 hours dark. Loud intermittent noise should be kept to a minimum. For feeding, conventional laboratory diets may be used with an unlimited supply of drinking water. The choice of diet may be influenced by the need to ensure a suitable admixture of a test substance when administered by this method. Animals may be housed individually, or be caged in small groups of the same sex.

##### 1.4.3 Preparation of animals

Healthy young animals are randomly assigned to the treatment and control groups. Cages should be arranged in such a way that possible effects due to cage placement are minimized. The animals are identified uniquely and kept in their cages for at least (5) five days prior the start of the study to allow for acclimatization to the laboratory conditions.

##### 1.4.4 Route of administration and preparation of doses

This Test Method specifically addresses the oral administration of the test substance. Oral administration may be by gavage, in the diet, in drinking water or by capsules. Other routes of administration (e.g. dermal or inhalation) can be used but may require modification of the procedures recommended. Considerations of the choice of the route of administration depend on the human exposure profile and available toxicological or kinetic information. The rationale for choosing the route of administration as well as resulting modifications to the procedures of this Test Method should be indicated.

Where necessary, the test substance may be dissolved or suspended in a suitable vehicle. It is recommended that the use of an aqueous solution/suspension be considered first, followed by consideration of a solution/suspension in oil (e.g., corn oil) and then by possible solution/suspension in other vehicle. The toxic characteristics of the vehicle must be known. In addition, consideration should be given to the following characteristics of the vehicle: effects of the vehicle on absorption, distribution, metabolism, or retention of the test substance which may alter its toxic characteristics; and effects on the food or water consumption or the nutritional status of the animals.

#### 1.5 PROCEDURES

##### 1.5.1 Number and sex animals

When the study is conducted as a separate study, at least 20 animals (10 females and 10 males) should be used in each dose and control group for the evaluation of detailed clinical and functional observations. At least five males and five females, selected from these 10 males and 10 females, should be perfused *in situ* and used for detailed neurohistopathology at the end of the study. In cases where only a limited number

of animals in a given dose group are observed for signs of neurotoxic effects, consideration should be given to the inclusion of these animals in those selected for perfusion. When the study is conducted in combination with a repeated dose toxicity study, adequate numbers of animals should be used to meet the objectives of both studies. The minimum numbers of animals per group for various combinations of studies are given in Table 1. If interim kills or recovery groups for observation of reversibility, persistence or delayed occurrence of toxic effects post treatment are planned or when supplemental observations are considered, then the number of animals should be increased to ensure that the number of animals required for observation and histopathology are available.

#### 1.5.2 **Treatment and control group**

At least three dose groups and a control group should generally be used, but if from the assessment of other data, no effects would be expected at a repeated dose of 1 000 mg/kg body weight/day, a limit test may be performed. If there are no suitable data available, a range finding study may be performed to aid in the determination of the doses to be used. Except for treatment with the test substance, animals in the control group should be handled in an identical manner to the test group subjects. If a vehicle is used in administering the test substance, the control group should receive the vehicle at the highest volume used.

#### 1.5.3 **Reliability check**

The laboratory performing the study should present data demonstrating its capability to carry out the study and the sensitivity of the procedures used. Such data should provide evidence of the ability to detect and quantify, as appropriate, changes in the different end points recommended for observation, such as autonomic signs, sensory reactivity, limb grip strength and motor activity. Information on chemicals that cause different types of neurotoxic responses and could be used as positive control substances can be found in references 2 to 9. Historical data may be used if the essential aspects of the experimental procedures remain the same. Periodic updating of historical data is recommended. New data that demonstrate the continuing sensitivity of the procedures should be developed when some essential element of the conduct of the test or procedures has been changed by the performing laboratory.

#### 1.5.4 **Dose selection**

Dose levels should be selected by taking into account any previously observed toxicity and kinetic data available for the test compound or related materials. The highest dose level should be chosen with the aim of inducing neurotoxic effects or clear systemic toxic effects. Thereafter, a descending sequence of dose levels should be selected with a view to demonstrating any dose-related response and no-observed-adverse effect (NOAEL) at the lowest dose level. In principle, dose levels should be set so that primary toxic effects on the nervous system can be distinguished from effects related to systemic toxicity. Two to three intervals are frequently optimum and addition of a fourth test group is often preferable to using very large intervals (e.g., more than a factor of 10) between dosages. Where there is a reasonable estimation of human exposure this should also be taken into account.

#### 1.5.5 **Limit test**

If a study at one dose level of at least 1 000 mg/kg body weight/day, using the procedures described, produces no observable neurotoxic effects and if toxicity would not be expected based upon data from structurally related compounds, then a full study using three dose levels may not be considered necessary. Expected human exposure may indicate the need for a higher oral dose level to be used in the limit test. For other types of administration, such as inhalation or dermal application, the physical chemical properties of the test substance often may dictate the maximum attainable level of exposure. For the conduct of an oral acute study, the dose for a limit test should be at least 2 000 mg/kg.

#### 1.5.6 **Administration of doses**

The animals are dosed with the test substance daily, seven days each week, for a period at least 28 days; use of a five-day dosing regime or a shorter exposure period needs to be justified. When the test substance is administered by gavage, this should be done in a single dose using a stomach tube or a suitable

intubation cannula. The maximum volume of a liquid that can be administered at one time depends on the size of the test animals. The volume should not exceed 1 ml/100 g body weight. However in the case of aqueous solutions, the use of up to 2 ml/100 g body weight can be considered. Except for irritating or corrosive substances, which will normally reveal exacerbated effects with higher concentrations, variability in test volume should be minimized by adjusting the concentration to ensure a constant volume at all dose levels.

For substances administered via the diet or drinking water, it is important to ensure that the quantities of the test substance involved do not interfere with normal nutrition or water balance. When the test substance is administered in the diet either a constant dietary concentration (ppm) or a constant dose level in terms of the animals' body weight may be used; the alternative used must be specified. For a substance administered by gavage, the dose should be given at similar times each day, and adjusted as necessary to maintain a constant dose level in terms of animal body weight. Where a repeat dose study is used as a preliminary to a long term study, a similar diet should be used in both studies. For acute studies, if a single dose is not possible, the dose may be given in smaller fractions over a period not exceeding 24 hours.

## 1.6 OBSERVATION

### 1.6.1 **Frequency of observations and tests**

In repeated dose studies, the observation period should cover the dosage period. In acute studies, 14-day post-treatment period should be observed. For animals in satellite groups which are kept without exposure during a post-treatment period, observations should cover this period as well.

Observations should be made with sufficient frequency to maximize the probability of detection of any behavioural and/or neurological abnormalities. Observations should be made preferably at the same times each day with consideration given to the peak period of anticipated effects after dosing. The frequency of clinical observations and functional tests is summarized in Table 2. If kinetic or other data generated from previous studies indicates the need to use different time points for observations, tests or post-observation periods, an alternative schedule should be adopted in order to achieve maximum information. The rationale for changes to the schedule should be provided.

#### 1.6.1.1 *Observations of general health condition and mortality/morbidity*

All animals should be carefully observed at least once daily with respect to their health condition as well as at least twice daily for morbidity and mortality.

#### 1.6.1.2 *Detailed clinical observations*

Detailed clinical observations should be made on all animals selected for this purpose (see Table 1) once before the first exposure (to allow for within-subject comparisons) and at different intervals thereafter, dependant on the duration of the study (see Table 2). Detailed clinical observations on satellite recovery groups should be made at the end of the recovery period. Detailed clinical observations should be made outside the home cage in a standard arena. They should be carefully recorded using scoring systems that include criteria or scoring scales for each measurement in the observations. The criteria or scales used should be explicitly defined by the testing laboratory. Effort should be made to ensure that variations in the test conditions are minimal (not systematically related to treatment) and that observations are conducted by trained observers unaware of the actual treatment.

It is recommended that the observations be carried out in a structured fashion in which well-defined criteria (including the definition of the normal "range") are systematically applied to each animal at each observation time. The "normal range" should be adequately documented. All observed signs should be recorded. Whenever feasible, the magnitude of the observed signs should also be recorded. Clinical observations should include, but not be limited to, changes in skin, fur, eyes, mucous membranes, occurrence of secretions and excretions and autonomic activity (e.g., lacrimation, piloerection, pupil size, unusual respiratory pattern and/or mouth breathing, any unusual signs of urination or defecation, and discoloured urine).

Any unusual responses with respect to body position, activity level (e.g., decreased or increased exploration of the standard arena) and co-ordination of movement should also be noted. Changes in gait (e.g., waddling, ataxia), posture (e.g., hunched-back) and reactivity to handling, placing or other environmental stimuli, as well as the presence of clonic or tonic movements, convulsions or tremors, stereotypes (e.g., excessive grooming, unusual head movements, repetitive circling) or bizarre behaviour (e.g., biting or excessive licking, self mutilation, walking backwards, vocalization) or aggression should be recorded.

#### 1.6.1.3 *Functional tests*

Similar to the detailed clinical observations, functional tests should also be conducted once prior to exposure and frequently thereafter in all animals selected for this purpose (see Table 1). The frequency of functional testing is also dependent on the study duration (see Table 2). In addition to the observation periods as set out in Table 2, functional observations on satellite recovery groups should also be made as close as possible to the terminal kill. Functional tests should include sensory reactivity to stimuli of different modalities [e.g., auditory, visual and proprioceptive stimuli (5)(6)(7)], assessment of limb grip strength (8) and assessment of motor activity (9). Motor activity should be measured with an automated device capable of detecting both decreases and increases in activity. If another defined system is used it should be quantitative and its sensitivity and reliability should be demonstrated. Each device should be tested to ensure reliability across time and consistency between devices. Further details of the procedures that can be followed are given in the respective references. If there are no data (e.g. structure-activity, epidemiological data, other toxicology studies) to indicate the potential neurotoxic effects, the inclusion of more specialized tests of sensory and motor function or learning and memory to examine these possible effects in greater details should be considered. More information on more specialized tests and their use is provided in (1).

Exceptionally, animals that reveal signs of toxicity to an extent that would significantly interfere with the functional test may be omitted from that test. Justification for the elimination of animals from a functional test should be provided.

#### 1.6.2 **Body weight and food/water consumption**

For studies up to 90 days duration, all animals should be weighed at least once a week and measurements should be made of food consumption (water consumption, when the test substance is administered by that medium) at least weekly. For long term studies, all animals should be weighed at least once at week for the first 13 weeks and at least once every 4 weeks thereafter. Measurements should be made of food consumption (water consumption, when the test substance is administered by that medium) at least weekly for the first 13 weeks and then at approximately three-month intervals unless the health status or body weight changes dictate otherwise.

#### 1.6.3 **Ophthalmology**

For studies longer than 28 days duration, ophthalmologic examination, using an ophthalmoscope or an equivalent suitable instrument, should be made prior to the administration of the test substance and at the termination of the study, preferably on all animals, but at least on animals in the high dose and control groups. If changes in the eyes are detected or, if clinical signs indicate the need, all animals should be examined. For long term studies, an ophthalmologic examination should also be carried out at 13 weeks. Ophthalmologic examinations need not to be conducted if this data is already available from others studies of similar duration and at similar dose levels.

#### 1.6.4 **Haematology and clinical biochemistry**

When the neurotoxicity study is carried out in combination with a repeated dose systemic toxicity study, haematological examinations and clinical biochemistry determinations should be carried out as set out in the respective Method of the systemic toxicity study. Collection of samples should be carried out in such a way that any potential effects on neurobehaviour are minimized.

#### 1.6.5 **Histopathology**

The neuropathological examination should be designed to complement and extend the observations made during the *in vivo* phase of the study. Tissues from at least 5 animals/sex/group (see Table 1 and next paragraph) should be fixed *in situ*, using generally recognized perfusion and fixation techniques (see

reference 3, chapter 5 and reference 4, chapter 50). Any observable gross changes should be recorded. When the study is conducted as a stand-alone study screen for neurotoxicity or to characterize neurotoxic effects, the remainder of the animals may be used either for specific neurobehavioural (10)(11), neuropathological (10)(11)(12)(13), neurochemical (10)(11)(14)(15) or electrophysiological (10)(11)(16)(17) procedures that may supplement the procedures and examinations described here, or to increase the number of subjects examined for histopathology. These supplementary procedures are of particular use when empirical observations or anticipated effects indicate a specific type or target of neurotoxicity (2)(3). Alternatively, the remainder of the animals can also be used for routine pathological evaluations as described in Method for repeated dose studies.

A general staining procedure, such as haematoxylin and eosin (H&E), should be performed on all tissue specimens embedded in paraffin and microscopic examination should be carried out. If signs of peripheral neuropathy are observed or suspected, plastic-embedded samples of peripheral nerve tissue should be examined. Clinical signs may also suggest additional sites for examination or the use of special staining procedures. Guidance on additional sites to be examined can be found in (3)(4). Appropriate special stains to demonstrate specific types of pathological change may also be helpful (18).

Representative sections of the central and peripheral nervous system should be examined histologically (see reference 3, chapter 5 and reference 4, chapter 50). The areas examined should normally include: the forebrain, the centre of the cerebrum, including a section through the hippocampus, the midbrain, the cerebellum, the pons, the medulla oblongata, the eye with optic nerve and retina, the spinal cord at the cervical and lumbar swellings, the dorsal root ganglia, the dorsal and ventral root fibres, the proximal sciatic nerve, the proximal tibial nerve (at the knee) and the tibial nerve calf muscle branches. The spinal cord and peripheral nerve sections should include both cross or transverse and longitudinal sections. Attention should be given to the vasculature of the nervous system. A sample of skeletal muscle, particularly calf muscle, should also be examined. Special attention should be paid to sites with cellular and fibre structure and pattern in the CNS and PNS known to be particularly affected by neurotoxicants.

Guidance on neuropathological alterations that typically result from toxicant exposure can be found in the references (3)(4). A stepwise examination of tissue samples is recommended in which sections from the high dose group are first compared with those of the control group. If no neuropathological alterations are observed in the samples from these groups, subsequent analysis is not required. If neuropathological alterations are observed in the high dose group, sample from each of the potentially affected tissues from the intermediate and low dose groups should then be coded and examined sequentially.

If any evidence of neuropathological alterations is found in the qualitative examination, then a second examination should be performed on all regions of the nervous system showing these alterations. Sections from all dose groups from each of the potentially affected regions should be coded and examined at random without knowledge of the code. The frequency and severity of each lesion should be recorded. After all regions from all dose groups have been rated, the code can be broken and statistical analysis performed to evaluate dose-response relationships. Examples of different degrees of severity of each lesion should be described.

The neuropathological findings should be evaluated in the context of behavioural observations and measurements, as well as other data from preceding and concurrent systemic toxicity studies of the test substance.

## 2. DATA

### 2.1 TREATMENT OF RESULTS

Individual data should be provided. Additionally, all data should be summarized in tabular form showing for each test or control group the number of animals at the start of the test, the number of animals found dead during the test or killed for humane reasons and the time of any death or humane kill, the number showing signs of toxicity, a description of the signs of toxicity observed, including time of onset, duration, type and severity of any toxic effects, the number of animals showing lesions, including the type and severity of the lesion(s).



## 2.2 EVALUATION AND INTERPRETATION OF RESULTS

The findings of the study should be evaluated in terms of the incidence, severity and correlation of neurobehavioural and neuropathological effects (neurochemical or electrophysiological effects as well if supplementary examinations are included) and any other adverse effects observed. When possible, numerical results should be evaluated by an appropriate and generally acceptable statistical method. The statistical methods should be selected during the design of the study.

## 3. REPORTING

### 3.1 TEST REPORT

The test report must include the following information:

Test substance:

- physical nature (including isomerism, purity and physicochemical properties);
- identification data.

Vehicle (if appropriate):

- justification for choice of vehicle.

Test animals:

- species/strain used;
- number, age and sex of animals;
- source, housing conditions, acclimatization, diet, etc;
- individual weights of animals at the start of the test.

Test conditions:

- details of test substance formulation/diet preparation, achieved concentration, stability and homogeneity of the preparation;
- specification of the doses administered, including details of the vehicle, volume and physical form of the material administered;
- details of the administration of the test substance;
- rationale for dose levels selected;
- rationale for the route and duration of the exposure;
- conversion from diet/drinking water test substance concentration (ppm) to the actual dose (mg/kg body weight/day), if applicable;
- details of the food and water quality.

Observation and Test Procedures:

- details of the assignment of animals in each group to the perfusion subgroups;
- details of scoring systems, including criteria and scoring scales for each measurement in the detailed clinical observations;

- details on the functional tests for sensory reactivity to stimuli of different modalities (e.g., auditory, visual and proprioceptive); for assessment of limb grip strength; for motor activity assessment (including details of automated devices for detecting activity); and other procedures used;
- details of ophthalmologic examinations and, if appropriate, haematological examinations and clinical biochemistry tests with relevant base-line values;
- details for specific neurobehavioural, neuropathological, neurochemical or electrophysiological procedures.

Results:

- body weight/body weight changes including body weight at kill;
- food consumption and water consumption, as appropriate;
- toxic response data by sex and dose level, including signs of toxicity or mortality;
- nature, severity and duration (time of onset and subsequent course) of the detailed clinical observations (whether reversible or not);
- a detailed description of all functional test results;
- necropsy findings;
- a detailed description of all neurobehavioural, neuropathological, and neurochemical or electrophysiological findings, if available;
- absorption and metabolism data, if available;
- statistical treatment of results, where appropriate.

Discussion of results:

- dose response information;
- relationship of any other toxic effects to a conclusion about the neurotoxic potential of the test chemical;
- no-observed-adverse effect level.

Conclusions:

- a specific statement of the overall neurotoxicity of the test chemical is encouraged.

4. **REFERENCES**

- (1) OECD Guidance Document on Neurotoxicity Testing Strategies and Test Methods. OECD, Paris, In Preparation.
- (2) Test Guideline for a Developmental Neurotoxicity Study, OECD Guidelines for the Testing of Chemicals. In preparation.
- (3) World Health Organization (WHO) (1986). Environmental Health Criteria document 60: Principles and Methods for the Assessment of Neurotoxicity associated with Exposure to Chemicals.
- (4) Spencer, P.S. and Schaumburg, H.H. (1980). Experimental and Clinical Neurotoxicology. Eds. Spencer, P.S. and Schaumburg, H.H. eds. Williams and Wilkins, Baltimore/ London.
- (5) Tupper, D.E. and Wallace, R.B. (1980). Utility of the Neurological Examination in Rats. *Acta Neurobiol. Exp.*, 40, 999-1003.

- (6) Gad, S.C. (1982). A Neuromuscular Screen for Use in Industrial Toxicology. *J. Toxicol. Environ. Health*, 9, 691-704.
- (7) Moser, V.C., McDaniel, K.M. and Phillips, P.M. (1991). Rat Strain and Stock Comparisons Using a Functional Observational Battery: Baseline Values and Effects of amitraz. *Toxic. Appl. Pharmacol.*, 108, 267-283.
- (8) Meyer, O.A., Tilson, H.A., Byrd, W.C. and Riley, M.T. (1979). A Method for the Routine Assessment of Fore- and Hind- limb Grip Strength of Rats and Mice. *Neurobehav. Toxicol.*, 1, 233-236.
- (9) Crofton, K.M., Haward, J.L., Moser, V.C., Gill, M.W., Reirer, L.W., Tilson, H.A. and MacPhail, R.C. (1991) Interlaboratory Comparison of Motor Activity Experiments: Implication for Neurotoxicological Assessments. *Neurotoxicol. Teratol.*, 13, 599-609.
- (10) Tilson, H.A., and Mitchell, C.L. eds. (1992). *Neurotoxicology Target Organ Toxicology Series*. Raven Press, New York.
- (11) Chang, L.W., ed. (1995). *Principles of Neurotoxicology*. Marcel Dekker, New York.
- (12) Broxup, B. (1991). Neuropathology as a screen for Neurotoxicity Assessment. *J. Amer. Coll. Toxicol.*, 10, 689-695.
- (13) Moser, V.C., Anthony, D.C., Sette, W.F. and MacPhail, R.C. (1992). Comparison of Subchronic Neurotoxicity of 2-Hydroxyethyl Acrylate and Acrylamide in Rats. *Fund. Appl.Toxicol.*, 18, 343-352.
- (14) O'Callaghan, J.P. (1988). Neurotypic and Gliotypic Proteins as Biochemical Markers of Neurotoxicity. *Eurotoxicol. Teratol.*, 10, 445-452.
- (15) O'Callaghan J.P. and Miller, D.B. (1988). Acute Exposure of the Neonatal Rat to Triethyltin Results in Persistent Changes in Neurotypic and Gliotypic Proteins. *J. Pharmacol. Exp. Ther.*, 244, 368-378.
- (16) Fox, D.A., Lowndes, H.E. and Birkamper, G.G. (1982). Electrophysiological Techniques in Neurotoxicology. In: *Nervous System Toxicology*. Mitchell, C.L. ed. Raven Press, New York, pp 299-335.
- (17) Johnson, B.L. (1980). Electrophysiological Methods in neurotoxicity Testing. In: *Experimental and Clinical Neurotoxicology*. Spencer, P.S. and Schaumburg, H.H. eds., Williams and Wilkins Co., Baltimore/London, pp. 726-742.
- (18) Bancroft, J.D. and Steven A. (1990). *Theory and Practice of Histological Techniques*. Chapter 17, *Neuropathological Techniques*. Lowe, James and Cox, Gordon eds. Churchill Livingstone.

Table 1

**Minimum numbers of animals needed per group when the neurotoxicity study is conducted separately or in combination with studies**

|   | NEUROTOXICITY STUDY CONDUCTED AS: |                                      |   |   |
|---|-----------------------------------|--------------------------------------|---|---|
|   | Separate study                    | Combined study with the 28-day study | Combined study with the 90-day study              | Combined study with the chronic toxicity study    |
| Total number of animals per group   | 10 males and 10 females           | 10 males and 10 females              | 15 males and 15 females                           | 25 males and 25 females                           |
| Number of animals selected for functional testing including detailed clinical observations  | 10 males and 10 females           | 10 males and 10 females              | 10 males and 10 females                           | 10 males and 10 females                           |
| Number of animals selected per perfusion <i>in situ</i> and neurohistopathology   | 5 males and 5 females             | 5 males and 5 females                | 5 males and 5 females                             | 5 males and 5 females                             |
| Number of animals selected for repeated dose/subchronic/chronic toxicity observations, haematology, clinical biochemistry, histopathology, etc. as indicate in the respective <i>Guidelines</i> |                                   | 5 males and 5 females                | 10 males <sup>†</sup> and 10 females <sup>†</sup> | 20 males <sup>†</sup> and 20 females <sup>†</sup> |
| Supplemental observations, as appropriate   | 5 males and 5 females             |                                      |   |   |

† Includes five animals selected for functional testing and detailed clinical observations as part of the neurotoxicity study

Table 2

## Frequency of clinical observation and functional tests

| Type of observations                            |                                | Study duration  |   |   |  |
|---|--------------------------------|---|---|---|--|
|   |                                | Acute   | 28-day  | 90-day  | Chronic  |
| In all animals                                  | General health condition       | daily   | daily   | daily   | daily  |
|   | Mortality/morbidity            | Twice daily   | Twice daily   | Twice daily   | Twice daily  |
| In animals selected for functional observations | Detailed clinical observations | <ul style="list-style-type: none"> <li>— prior to first exposure</li> <li>— within 8 hours of dosing at estimate time of peak effect</li> <li>— at day 7 and 14 after dosing</li> </ul> | <ul style="list-style-type: none"> <li>— prior to first exposure</li> <li>— once weekly thereafter</li> </ul>   | <ul style="list-style-type: none"> <li>— prior to first exposure</li> <li>— once during the first or second week of exposure</li> <li>— monthly thereafter</li> </ul> | <ul style="list-style-type: none"> <li>— prior to first exposure</li> <li>— once at the end of the first month of exposure</li> <li>— every three months thereafter</li> </ul> |
|   | Functional tests               | <ul style="list-style-type: none"> <li>— prior to first exposure</li> <li>— within 8 hours of dosing at estimate time of peak effect</li> <li>— at day 7 and 14 after dosing</li> </ul> | <ul style="list-style-type: none"> <li>— prior to first exposure</li> <li>— during the fourth week of treatment as close as possible to the end of the exposure period</li> </ul> | <ul style="list-style-type: none"> <li>— prior to first exposure</li> <li>— once during the first or second week of exposure</li> <li>— monthly thereafter</li> </ul> | <ul style="list-style-type: none"> <li>— prior to first exposure</li> <li>— once at the end of the first month of exposure</li> <li>— every three months thereafter</li> </ul> |

## ANNEX 2I

**'C.21. SOIL MICROORGANISMS: NITROGEN TRANSFORMATION TEST****1. METHOD**

This test method is a replicate of OECD TG 216 (2000).

**1.1 INTRODUCTION**

This Testing method describes a laboratory method designed to investigate the long-term effects of chemicals, after a single exposure, on nitrogen transformation activity of soil microorganisms. The test is principally based on the recommendations of the European and Mediterranean Plant Protection Organization (1). However, other guideline, including those of the German Biologische Bundesanstalt (2), the US Environmental Protection Agency (3) SETAC (4) and the International Organization for Standardization (5), were also taken into account. An OECD Workshop on soil/sediment Selection held at Belgirate, Italy, in 1995 (6) agreed on the number and type of soils for use in this test. Recommendations for collection, handling and storage of soil sample are based on an ISO Guidance Document (7) and recommendations from the Belgirate Workshop. In the assessment and evaluation of toxic characteristics of test substances, determination of effects on soil microbial activity may be required, e.g. when data on the potential side effects of crop protection products on soil microflora are required or when exposure of soil microorganisms to chemicals other than crop protection products is expected. The nitrogen transformation test is carried out to determine the effects of such chemicals on soil microflora. If agrochemicals (e.g. crop protection products, fertilisers, forestry chemicals) are tested, both nitrogen transformation and carbon transformation tests are conducted. If non agrochemicals are tested, the nitrogen transformation test is sufficient. However, if EC<sub>50</sub> values of the nitrogen transformation test for such chemicals fall within the range found for commercially available nitrification inhibitors (e.g. nitrapyrin), a carbon transformation test can be conducted to gain further information.

Soils consist of living and non-living components which exist in complex and heterogeneous mixtures. Microorganisms play an important role in break-down and transformation of organic matter in fertile soils with many species contributing to different aspects of soil fertility. Any long-term interference with these biochemical processes could potentially interfere with nutrient cycling and this could alter soil fertility. Transformation of carbon and nitrogen occurs in all fertile soils. Although the microbial communities responsible for these processes differ from soil to soil, the pathways of transformation are essentially the same.

This Testing method described is designed to detect long-term adverse effects of a substance on the process of nitrogen transformation in aerobic surface soils. The test method also allows estimation of the effects of substances on carbon transformation by the soil microflora. Nitrate formation takes place subsequent to the degradation of carbon-nitrogen bonds. Therefore, if equal rates of nitrate production are found in treated and control soils, it is highly probable that the major carbon degradation pathways are intact and functional. The substrate chosen for the test (powdered lucerne meal) has a favourable carbon to nitrogen ratio (usually between 12/1 and 16/1). Because of this, carbon starvation is reduced during the test and if microbial communities are damaged by a chemical, they might recover within 100 days.

The tests from which this Testing Method was developed were primarily designed for substances for which the amount reaching the soil can be anticipated. This is the case, for example, for crop protection products for which the application rate in the field is known. For agrochemicals, testing of two doses relevant to the anticipated or predicted application rate is sufficient. Agrochemicals can be tested as active ingredients (a.i.) or as formulated products. However, the test is not limited to agrochemicals. By changing both the amounts of test substance applied to the soil, and the way in which the data are evaluated, the test can also be used for chemicals for which the amount expected to reach the soil is not known. Thus, with chemicals other than agrochemicals, the effects of a series of concentrations on nitrogen transformation are determined. The data from these tests are used to prepare a dose-response curve and calculate EC<sub>x</sub> values, where x is defined % effect.

## 1.2 DEFINITIONS

**Nitrogen transformation:** is the ultimate degradation by microorganisms of nitrogen-containing organic matter, via the process of ammonification and nitrification, to the respective inorganic end-product nitrate.

**EC<sub>x</sub> (Effective Concentration):** is the concentration of the test substance in soil that results in a x percent inhibition of nitrogen transformation to nitrate.

**EC<sub>50</sub> (Median Effective Concentration):** is the concentration of the test substance in soil that results in a 50 percent (50 %) inhibition of nitrogen transformation to nitrate.

## 1.3 REFERENCE SUBSTANCES

None.

## 1.4 Principle of the test method

Sieved soil is amended with powdered plant meal and either treated with the test substance or left untreated (control). If agrochemicals are tested, a minimum of two test concentrations are recommended and these should be chosen in relation to the highest concentration anticipated in the field. After 0, 7, 14 days and 28 days of incubation, samples of treated and control soils are extracted with an appropriate solvent, and the quantities of nitrate in the extracts are determined. The rate of nitrate formation in treated samples is compared with the rate in the controls, and the percent deviation of the treated from the control is calculated. All tests run for at least 28 days. If, on the 28th day, differences between treated and untreated soils are equal to or greater than 25 %, measurements are continued to a maximum of 100 days. If non agrochemicals are tested, a series of concentrations of the test substance are added to samples of the soil, and the quantities of nitrate formed in treated and control samples are measured after 28 days of incubation. Results from tests with multiple concentrations are analysed using a regression model, and the EC<sub>x</sub> values are calculated (i.e. EC<sub>50</sub>, EC<sub>25</sub> and/or EC<sub>10</sub>). See definitions.

## 1.5 VALIDITY OF THE TEST

Evaluations of test results with agrochemicals are based on relatively small differences (i.e. average value  $\pm 25$  %) between nitrate concentrations in control and treated soil samples, so large variations in the controls can lead to false results. Therefore, the variation between replicate control samples should be less than  $\pm 15$  %.

## 1.6 DESCRIPTION OF THE TEST METHOD

### 1.6.1 Apparatus

Test containers made of chemically inert material are used. They should be of a suitable capacity in compliance with the procedure used for incubation of soils, i.e. incubation in bulk or as a series of individual soil samples (see section 1.7.1.2). Care should be taken both to minimise water loss and to allow gas exchange during the test (e.g. the test containers may be covered with perforated polyethylene foil). When volatile substances are tested, sealable and gas-tight containers should be used. These should be of a size such that approximately one quarter of their volume is filled with the soil sample.

Standard laboratory equipment including the following is used:

- agitation device: mechanical shaker or equivalent equipment;
- centrifuge (3 000 g) or filtration device (using nitrate-free filter paper);
- instrument of adequate sensitivity and reproducibility for nitrate analysis.

### 1.6.2 Selection and number of soils

One single soil is used. The recommended soil characteristics are as follows:

- sand content: not less than 50 % and not greater than 75 %;
- pH: 5,5-7,5;

- organic carbon content: 0.5 - 1.5 %;
  
- the microbial biomass should be measured (8)(9) and its carbon content should be at least 1 % of the total soil organic carbon.

In most cases, a soil with these characteristics represents a worst case situation, since adsorption of the test chemical is minimum and its availability to the microflora is maximum. Consequently, tests with other soils are generally unnecessary. However, in certain circumstances, e.g. where the anticipated major use of the test substance is in particular soils such as acidic forest soils, or for electrostatically charged chemicals, it may be necessary to use an additional soil.

### 1.6.3 **Collection and storage of soil samples**

#### 1.6.3.1 *Collection*

Detailed information on the history of the field site from where the test soil is collected should be available. Details include exact location, vegetation cover, dates of treatments with crop protection products, treatments with organic and inorganic fertilisers, additions of biological materials or accidental contaminations. The site chosen for soil collection should be one which allows long-term use. Permanent pastures, fields with annual cereal crops (except maize) or densely sown green manures are suitable. The selected sampling site should not have been treated with crop protection products for a minimum of one year before sampling. Also, no organic fertiliser should have been applied for at least six months. The use of mineral fertiliser is only acceptable when in accordance with the requirements of the crop and soil samples should not be taken until at least three months after fertiliser application. The use of soil treated with fertilisers with known biocidal effects (e.g. calcium cyanamide) should be avoided.

Sampling should be avoided during or immediately following long periods (greater than 30 days) of drought or water logging. For ploughed soils, samples should be taken from a depth of 0 down to 20 cm. For grassland (pasture) or other soils where ploughing does not occur over longer periods (at least one growing season), the maximum depth of sampling may be slightly more than 20 cm (e.g. to 25 cm).

Soil samples should be transported using containers and under temperature conditions which guarantee that the initial soil properties are not significantly altered.

#### 1.6.3.2 *Storage*

The use of soils freshly collected from the field is preferred. If storage in the laboratory cannot be avoided, soils may be stored in the dark at  $4\pm 2^{\circ}\text{C}$  for a maximum of three months. During the storage of soils, aerobic conditions must be ensured. If soils are collected from areas where they are frozen for at least three months per year, storage for six months at minus  $18^{\circ}\text{C}$  to minus  $22^{\circ}\text{C}$  can be considered. The microbial biomass of stored soils is measured prior to each experiment and the carbon in the biomass should be at least 1 % of the total soil organic carbon content (see section 1.6.2).

### 1.6.4 **Handling and preparation of soil for the test**

#### 1.6.4.1 *Pre-incubation*

If the soil was stored (see section 1.6.3.2), pre-incubation is recommended for a period between 2 and 28 days. The temperature and moisture content of the soil during pre-incubation should be similar to that used in the test (see sections 1.6.4.2 and 1.7.1.3).

#### 1.6.4.2 *Physical-chemical characteristics*

The soil is manually cleared of large objects (e.g. stones, parts of plants, etc.) and then moist sieved without excess drying to a particle size less than or equal to 2 mm. The moisture content of the soil sample should be adjusted with distilled or deionised water to a value between 40 % and 60 % of the maximum water holding capacity.



#### 1.6.4.3 *Amendment with organic substrate*

The soil should be amended with a suitable organic substrate, e.g. powdered lucerne-grass-green meal (main component: *Medicago sativa*) with a C/N ratio between 12/1 and 16/1. The recommended lucerne-soil ratio is 5 g of lucerne per kilogram of soil (dry weight).

#### 1.6.5 **Preparation of the test substance for the application to soil**

The test substance is normally applied using a carrier. The carrier can be water (for water soluble substances) or an inert solid such as fine quartz sand (particle size: 0.1-0.5mm). Liquid carriers other than water (e.g. organic solvents such as acetone, chloroform) should be avoided since they can damage the microflora. If sand is used as a carrier, it can be coated with the test substance dissolved or suspended in an appropriate solvent. In such cases, the solvent should be removed by evaporation before mixing with the soil. For an optimum distribution of the test substance in soil, a ratio of 10 g of sand per kilogram of soil (dry weight) is recommended. Control samples are treated with an equivalent amount of water and/or quartz sand only.

When testing volatile chemicals, losses during treatment should be avoided as far as possible and an attempt should be made to ensure homogeneous distribution in the soil (e.g. the test substance should be injected into the soil at several places).

#### 1.6.6 **Test concentrations**

If agrochemicals are tested, at least two concentrations should be used. The lower concentration should reflect at least the maximum amount expected to reach the soil under practical conditions whereas the higher concentration should be a multiple of the lower concentration. The concentrations of test substance added to soil are calculated assuming uniform incorporation to a depth of 5 cm and a soil bulk density of 1.5. For agrochemicals that are applied directly to soil, or for chemicals for which the quantity reaching the soil can be predicted, the test concentrations recommended are the maximum Predicted Environmental Concentration (PEC) and five times that concentration. Substances that are expected to be applied to soils several times in one season should be tested at concentrations derived from multiplying the PEC by the maximum anticipated number of applications. The upper concentration tested, however, should not exceed ten times the maximum single application rate. If non-agrochemicals are tested, a geometric series of at least five concentrations is used. The concentrations tested should cover the range needed to determine the EC<sub>x</sub> values.

### 1.7 PERFORMANCE OF THE TEST

#### 1.7.1 **Conditions of exposure**

##### 1.7.1.1 *Treatment and control*

If agrochemicals are tested, the soil is divided into three portions of equal weight. Two portions are mixed with the carrier containing the product, and the other is mixed with the carrier without the product (control). A minimum of three replicates for both treated and untreated soils is recommended. If non-agrochemicals are tested, the soil is divided into six portions of equal weight. Five of the samples are mixed with the carrier containing the test substance, and the sixth sample is mixed with the carrier without the chemical. Three replicates for both treatments and control are recommended. Care should be taken to ensure homogeneous distribution of the test substance in the treated soil samples. During mixing, compacting or balling of the soil should be avoided.

##### 1.7.1.2 *Incubation of soil samples*

Incubation of soil samples can be performed in two ways: as bulk samples of each treated and untreated soil or as a series of individual and equally sized subsamples of each treated and untreated soil. However, when volatile substances are tested, the test should only be performed with a series of individual subsamples. When soils are incubated in bulk, large quantities of each treated and untreated soils are prepared and subsamples to be analysed are taken as needed during the test. The amount initially prepared for each treatment and control depends on the size of the subsamples, the number of replicates used for analysis and the anticipated maximum number of sampling times. Soils incubated in bulk should be thoroughly mixed before subsampling. When soils are incubated as a series of individual soil samples, each treated and untreated bulk soil is divided into the required number of subsamples, and these are utilised as

needed. In the experiments where more than two sampling times can be anticipated, enough subsamples should be prepared to account for all replicates and all sampling times. At least three replicate samples of the test soil should be incubated under aerobic conditions (see section 1.7.1.1). During all tests, appropriate containers with sufficient headspace should be used to avoid development of anaerobic conditions. When volatile substances are tested, the test should only be performed with a series of individual subsamples.

#### 1.7.1.3 *Test conditions and duration*

The test is carried out in the dark at room temperature of  $20 \pm 2^\circ\text{C}$ . The moisture content of soil samples should be maintained during the test between 40 % and 60 % of the maximum water holding capacity of the soil (see section 1.6.4.2) with a range of  $\pm 5$  %. Distilled, deionized water can be added as needed.

The minimum duration of tests is 28 days. If agrochemicals are tested, the rates of nitrate formation in treated and control samples are compared. If these differ by more than 25 % on day 28, the test is continued until a difference equal to or less than 25 % is obtained, or for a maximum of 100 days, whichever is shorter. For non-agrochemicals, the test is terminated after 28 days. On day 28, the quantities of nitrate in treated and control soil samples are determined and the  $\text{EC}_x$  values are calculated.

### 1.7.2 **Sampling and analysis of soils**

#### 1.7.2.1 *Soil sampling schedule*

If agrochemicals are tested, soil samples are analysed for nitrate on days 0, 7, 14 and 28. If a prolonged test is required, further measurements should be made at 14 days intervals after day 28.

If non-agrochemicals are tested, at least five test concentrations are used and soil samples are analysed for nitrate at the beginning (day 0) and at the end of the exposure period (28 days). An intermediate measurement, e.g. at day 7, may be added if deemed necessary. The data obtained on day 28 are used to determine  $\text{EC}_x$  value for the chemical. If desired, data from day 0 control samples can be used to report the initial quantity of nitrate in the soil.

#### 1.7.2.2 *Analysis of soil samples*

The amount of nitrate formed in each treated and control replicate is determined at each sampling time. Nitrate is extracted from soil by shaking samples with a suitable extraction solvent, e.g. a 0.1 M potassium chloride solution. A ratio of 5 ml of KCl solution per gram dry weight equivalent of soil is recommended. To optimise extraction, containers holding soil and extraction solution should not be more than half full. The mixtures are shaken at 150 rpm for 60 minutes. The mixtures are centrifuged or filtered and the liquid phases are analysed for nitrate. Particle-free liquid extracts can be stored prior to analysis at  $20 \pm 5^\circ\text{C}$  for up to six months.

## 2. **DATA**

### 2.1 TREATMENT OF RESULTS

If tests are conducted with agrochemicals, the quantity of nitrate formed in each replicate soil sample should be recorded, and the mean values of all replicates should be provided in tabular form. Nitrogen transformation rates should be evaluated by appropriate and generally acceptable statistical methods (e.g. F-test, 5 % significance level). The quantities of nitrate formed are expressed in mg nitrate/kg dry weight soil/day. The nitrate formation rate in each treatment is compared with that in the control, and the percent deviation from the control is calculated.

If tests are conducted with non-agrochemicals, the quantity of nitrate formed in each replicate is determined, and a dose-response curve is prepared for estimation of the  $\text{EC}_x$  values. The quantities of nitrate (i.e. mg nitrate/kg dry weight soil) found in the treated samples after 28 days are compared to that found in the control. From these data, the % inhibition values for each test concentration are calculated.

These percentages are plotted against concentration, and statistical procedures are then used to calculate the  $EC_x$  values. Confidence limits ( $p = 0.95$ ) for the calculated  $EC_x$  are also determined using standard procedures (10)(11)(12).

Test substances that contain high quantities of nitrogen may contribute to the quantities of nitrate formed during the test. If these substances are tested at a high concentration (e.g. chemicals which are expected to be used in repeated applications) appropriate controls must be included in the test (i.e. soil plus test substance but without plant meal). Data from these controls must be accounted for in the  $EC_x$  calculations.

## 2.2 INTERPRETATION OF RESULTS

When results from tests with agrochemicals are evaluated, and the difference in the rates of nitrate formation between the lower treatment (i.e. the maximum predicted concentration) and control is equal to or less than 25 % at any sampling time after day 28, the product can be evaluated as having no long-term influence on nitrogen transformation in soils. When results from tests with chemicals other than agrochemicals are evaluated, the  $EC_{50}$ ,  $EC_{25}$  and/or  $EC_{10}$  values are used.

## 3. REPORTING

The test report must include the following information:

Complete identification of the soil used including:

- geographical reference of the site (latitude, longitude);
- information on the history of the site (i.e. vegetation cover, treatments with crop protection products, treatments with fertilisers, accidental contamination, etc.);
- use pattern (e.g. agricultural soil, forest, etc.);
- depth of sampling (cm);
- sand/silt/clay content (% dry weight);
- pH (in water);
- organic carbon content (% dry weight);
- nitrogen content (% dry weight);
- initial nitrate concentration (mg nitrate/kg dry weight);
- cation exchange capacity (mmol/kg);
- microbial biomass in terms of percentage of the total organic carbon;
- reference of the methods used for the determination of each parameter;
- all information relating to the collection and storage of soil samples;
- details of pre-incubation of soil if any.

Test substance:

- physical nature and, where relevant, physical-chemical properties;
- chemical identification data, where relevant, including structural formula, purity (i.e. for crop protection products the percentage of active ingredient), nitrogen content.

## Substrate:

- source of substrate;
- composition (i.e. lucerne meal, lucerne-grass-green meal);
- carbon, nitrogen content (% dry weight);
- sieve size (mm).

## Test conditions:

- details of the amendment of soil with organic substrate;
- number of concentrations of test chemical used and, where appropriate, justification of the selected concentrations;
- details of the application of test substance to soil;
- incubation temperature;
- soil moisture content at the beginning and during the test;
- method of soil incubation used (i.e. as bulk or as a series of individual subsamples);
- number of replicates;
- sampling times;
- method used for extraction of nitrate from soil;

## Results:

- analytical procedure and equipment used to analyse nitrate;
- tabulated data including individual and mean values for nitrate measurements;
- variation between the replicates in treated and control samples;
- explanations of corrections made in the calculations, if relevant;
- the percent variation in nitrate formation rates at each sampling time or, if appropriate, the EC<sub>50</sub> value with 95 per cent confidence limit, other EC<sub>x</sub> (i.e. EC<sub>25</sub> or EC<sub>10</sub>) with confidence intervals, and a graph of the dose-response curve;
- statistical treatment of results;
- all information and observations helpful for the interpretation of the results.

## 4.

**REFERENCES**

- (1) EPPO (1994). Decision-Making Scheme for the Environmental Risk Assessment of Plant Protection Chemicals. Chapter 7: Soil Microflora. EPPO Bulletin 24: 1-16, 1994.
- (2) BBA (1990). Effects on the Activity of the Soil Microflora. BBA Guidelines for the Official Testing of Plant Protection Products, VI, 1-1 (2nd eds., 1990).
- (3) EPA (1987). Soil Microbial Community Toxicity Test. EPA 40 CFR Part 797.3700. Toxic Substances Control Act Test Guidelines; Proposed rule. September 28, 1987.
- (4) SETAC-Europe (1995). Procedures for assessing the environmental fate and ecotoxicity of pesticides, Ed. M.R. Lynch, Pub. SETAC-Europe, Bruxelles.

- (5) ISO/DIS 14238 (1995). Soil Quality - Determination of Nitrogen Mineralisation and Nitrification in Soils and the Influence of Chemicals on these Processes. Technical Committee ISO/TC 190/SC 4: *Soil Quality - Biological Methods*.
- (6) OECD (1995). Final Report of the OECD Workshop on Selection of Soils/Sediments, Belgirate, Italie, 18-20 janvier 1995.
- (7) ISO 10381-6 (1993). Soil quality - Sampling. Guidance on the collection, handling and storage of soil for the assessment of aerobic microbial processes in the laboratory.
- (8) ISO 14240-1 (1997). Soil quality - Determination of soil microbial biomass - Part 1: Substrate-induced respiration method.
- (9) ISO 14240-2 (1997). Soil quality - Determination of soil microbial biomass - Part 2: Fumigation-extraction method.
- (10) Litchfield, J.T. and Wilcoxon F. (1949). A simplified method of evaluating dose-effect experiments. *Jour. Pharmacol. and Exper. Ther.*, 96, 99-113.
- (11) Finney, D.J. (1971). *Probit Analysis*. 3rd ed., Cambridge, London and New-York.
- (12) Finney, D.J. (1978). *Statistical Methods in biological Assay*. Griffin, Weycombe, UK.

**C.22. SOIL MICROORGANISMS: CARBON TRANSFORMATION TEST****1. METHOD**

This method is a replicate of OECD TG 217 (2000).

**1.1 INTRODUCTION**

This Testing method describes a laboratory method designed to investigate long term potential effects of a single exposure of crop protection products and possibly other chemicals on carbon transformation activity of soil microorganisms. The test is principally based on the recommendations of the European and Mediterranean Plant Protection Organization (1). However, other guideline, including those of the German Biologische Bundesanstalt (2), the US Environmental Protection Agency (3) and SETAC (4), were also taken into account. An OECD Workshop on Soil/Sediment Selection held at Belgirate, Italy, in 1995 (5) agreed on the number and type of soils for use in this test. Recommendations for collection, handling and storage of soil sample are based on an ISO Guidance Document (6) and recommendations from the Belgirate Workshop.

In the assessment and evaluation of toxic characteristics of test substances, determination of effects on soil microbial activity may be required, e.g. when data on the potential side effects of crop protection products on soil microflora are required or when exposure of soil microorganisms to chemicals other than crop protection products is expected. The carbon transformation test is carried out to determine the effects of such chemicals on soil microflora. If agrochemicals (e.g. crop protection products, fertilisers, forestry chemicals) are tested, both carbon transformation and nitrogen transformation tests are conducted. If non-agrochemicals are tested, the nitrogen transformation test is sufficient. However, if EC<sub>50</sub> values of the nitrogen transformation test for such chemicals fall within the range found for commercially available nitrification inhibitors (e.g. nitrapyrin), a carbon transformation test can be conducted to gain further information.

Soils consist of living and non-living components which exist in complex and heterogeneous mixtures. Microorganisms play an important role in breakdown and transformation of organic matter in fertile soils with many species contributing to different aspects of soil fertility. Any long-term interference with these biochemical processes could potentially interfere with nutrient cycling and this could alter the soil fertility. Transformation of carbon and nitrogen occurs in all fertile soils. Although the microbial communities responsible for these processes differ from soil to soil, the pathways of transformation are essentially the same.

This Testing Method is designed to detect long-term adverse effects of a substance on the process of carbon transformation in aerobic surface soils. The test is sensitive to changes in size and activity of microbial communities responsible for carbon transformation since it subjects these communities to both chemical stress and carbon starvation. A sandy soil low in organic matter is used. This soil is treated with the test substance and incubated under conditions that allow rapid microbial metabolism. Under these conditions, sources of readily available carbon in the soil are rapidly depleted. This causes carbon starvation which both kills microbial cells and induces dormancy and/or sporulation. If the test runs for more than 28 days, the sum of these reactions can be measured in (untreated soil) controls as a progressive loss of metabolically active microbial biomass (7). If the biomass in carbon-stressed soil, under the conditions of the test, is affected by the presence of a chemical, it may not return to the same level as the control. Hence, disturbances caused by the test substance at any time during the test will often last until the end of the test.

The tests from which this Testing Method was developed were primarily designed for substances for which the amount reaching the soil can be anticipated. This is the case, for example, for crop protection products for which the application rate in the field is known. For agrochemicals, testing of two doses relevant to the anticipated or predicted application rate is sufficient. Agrochemicals can be tested as active ingredients (a.i.) or as formulated products. However, the test is not limited to chemicals with predictable environmental concentrations. By changing both the amounts of test substance applied to the soil, and the way in which the data are evaluated, the test can also be used for chemicals for which the amount expected to reach the soil is not known. Thus, with non-agrochemicals, the effects of a series of concentrations on carbon transformation are determined. The data from these tests are used to prepare a dose-response curve and calculate EC<sub>x</sub> values, where x is defined % effect.

## 1.2 DEFINITIONS

**Carbon transformation:** is the degradation by microorganisms of organic matter to form inorganic end-product carbon dioxide.

**EC<sub>x</sub> (Effective Concentration):** is the concentration of the test substance in soil that results in a x percent inhibition of carbon transformation in carbon dioxide.

**EC<sub>50</sub> (Median Effective Concentration):** is the concentration of test substance in soil that results in a 50 per cent inhibition of carbon transformation in carbon dioxide.

## 1.3 REFERENCE SUBSTANCES

None.

## 1.4 PRINCIPLE OF THE TEST METHOD

Sieved soil is either treated with the test substance or left untreated (control). If agrochemicals are tested, a minimum of two test concentrations are recommended and these should be chosen in relation to the highest concentration anticipated in the field. After 0, 7, 14 and 28 days incubation, samples of treated and control soils are mixed with glucose, and glucose-induced respiration rates are measured for 12 consecutive hours. Respiration rates are expressed as carbon dioxide released (mg carbon dioxide/kg dry soil/h) or oxygen consumed (mg oxygen/kg soil/h). The mean respiration rate in the treated soil samples is compared with that in control and the percent deviation of the treated from the control is calculated. All tests run for at least 28 days. If, on the 28th day, differences between treated and untreated soils are equal to or greater than 25 % measurements are continued in 14 day intervals for a maximum of 100 days. If chemicals other than agrochemicals are tested, a series of concentrations of the test substance are added to samples of the soil, and glucose induced respiration rates (i.e. the mean of the quantities of carbon dioxide formed or oxygen consumed) are measured after 28 days. Results from tests with a series of concentrations are analysed using a regression model, and the EC<sub>x</sub> values are calculated (i.e. EC<sub>50</sub>, EC<sub>25</sub> and/or EC<sub>10</sub>). See definitions.

## 1.5 VALIDITY OF THE TEST

Evaluations of test results with agrochemicals are based on relatively small differences (i.e. average value  $\pm 25$  %) between the carbon dioxide released or the oxygen consumed in (or by) control and treated soil samples, so large variations in the controls can lead to false results. Therefore, the variation between replicate control samples should be less than  $\pm 15$  %.

## 1.6 DESCRIPTION OF THE TEST METHOD

1.6.1 **Apparatus**

Test containers made of chemically inert material are used. They should be of a suitable capacity in compliance with the procedure used for incubation of soils, i.e. incubation in bulk or as a series of individual soil samples (see section 1.7.1.2). Care should be taken both to minimise water loss and to allow gas exchange during the test (e.g. the test containers may be covered with perforated polyethylene foil). When volatile substances are tested, sealable and gas-tight containers should be used. These should be of a size such that approximately one quarter of their volume is filled with the soil sample.

For determination of glucose-induced respiration, incubation systems and instruments for measurement of carbon dioxide production or oxygen consumption are required. Examples of such systems and instruments are found in the literature (8) (9) (10) (11).

1.6.2 **Selection and number of soils**

One single soil is used. The recommended soil characteristics are as follows:

- sand content: not less than 50 % and not greater than 75 %;
- pH: 5.5-7.5;

- organic carbon content: 0.5-1.5 %;
- the microbial biomass should be measured (12)(13) and its carbon content should be at least 1 % of the total soil organic carbon.

In most cases, a soil with these characteristics represents a worst case situation, since adsorption of the test chemical is minimised and its availability to the microflora is maximum. Consequently, tests with other soils are generally unnecessary. However, in certain circumstances, e.g. where the anticipated major use of the test substance is in particular soils such as acidic forest soils, or for electrostatically charged chemicals, it may be necessary to substitute an additional soil.

### 1.6.3 **Collection and storage of soil samples**

#### 1.6.3.1 *Collection*

Detailed information on the history of the field site from where the test soil is collected should be available. Details include exact location, vegetation cover, dates of treatments with crop protection products, treatments with organic and inorganic fertilisers, additions of biological materials or accidental contaminations. The site chosen for soil collection should be one which allows long-term use. Permanent pastures, fields with annual cereal crops (except maize) or densely sown green manures are suitable. The selected sampling site should not have been treated with crop protection products for a minimum of one year before sampling. Also, no organic fertiliser should have been applied for at least six months. The use of mineral fertiliser is only acceptable when in accordance with the requirements of the crop and soil samples should not be taken until at least three months after fertiliser application. The use of soil treated with fertilisers with known biocidal effects (e.g. calcium cyanamide) should be avoided.

Sampling should be avoided during or immediately following long periods (greater than 30 days) of drought or water logging. For ploughed soils, samples should be taken from a depth of 0 down to 20 cm. For grassland (pasture) or other soils where ploughing does not occur over longer periods (at least one growing season), the maximum depth of sampling may be slightly more than 20 cm (e.g. to 25 cm). Soil samples should be transported using containers and under temperature conditions which guarantee that the initial soil properties are not significantly altered.

#### 1.6.3.2 *Storage*

The use of soils freshly collected from the field is preferred. If storage in the laboratory cannot be avoided, soils may be stored in the dark at  $4 \pm 2$  °C for a maximum of three months. During the storage of soils, aerobic conditions must be ensured. If soils are collected from areas where they are frozen for at least three months per year, storage for six months at minus 18 °C can be considered. The microbial biomass of stored soils is measured prior to each experiment and the carbon in the biomass should be at least 1 % of the total soil organic carbon content (see section 1.6.2).

### 1.6.4 **Handling and preparation of soil for the test**

#### 1.6.4.1 *Pre-incubation*

If the soil was stored (see sections 1.6.4.2 and 1.7.1.3), pre-incubation is recommended for a period between 2 and 28 days. The temperature and moisture content of the soil during pre-incubation should be similar to that used in the test (see sections 1.6.4.2 and 1.7.1.3).

#### 1.6.4.2 *Physical-chemical characteristics*

The soil is manually cleared of large objects (e.g. stones, parts of plants, etc.) and then moist sieved without excess drying to a particle size less than or equal to 2 mm. The moisture content of the soil sample should be adjusted with distilled or deionised water to a value between 40 % and 60 % of the maximum water holding capacity.

### 1.6.5 **Preparation of the test substance for the application to soil**

The test substance is normally applied using a carrier. The carrier can be water (for water soluble substances) or an inert solid such as fine quartz sand (particle size: 0.1-0.5 mm). Liquid carriers other than water (e.g. organic solvents such as acetone, chloroform) should be avoided since they can damage the



microflora. If sand is used as a carrier, it can be coated with the test substance dissolved or suspended in an appropriate solvent. In such cases, the solvent should be removed by evaporation before mixing with the soil. For an optimum distribution of the test substance in soil, a ratio of 10 g of sand per kilogram of soil (dry weight) is recommended. Control samples are treated with the equivalent amount of water and/or quartz sand only.

When testing volatile chemicals, losses during treatment should be avoided and an attempt should be made to ensure homogeneous distribution in the soil (e.g. the test substance should be injected into the soil at several places).

#### 1.6.6 **Test concentrations**

If crop protection products or other chemicals with predictable environmental concentrations are tested, at least two concentrations should be used. The lower concentration should reflect at least the maximum amount expected to reach the soil under practical conditions whereas the higher concentration should be a multiple of the lower concentration. The concentrations of test substance added to soil are calculated assuming uniform incorporation to a depth of 5 cm and a soil bulk density of 1.5. For agrochemicals that are applied directly to soil, or for chemicals for which the quantity reaching the soil can be predicted, the test concentrations recommended are the Predictable Environmental Concentration (PEC) and five times that concentration. Substances that are expected to be applied to soils several times in one season should be tested at concentrations derived from multiplying the PEC by the maximum anticipated number of applications. The upper concentration tested, however, should not exceed ten times the maximum single application rate.

If non-agrochemicals are tested, a geometric series of at least five concentrations is used. The concentrations tested should cover the range needed to determine the  $EC_x$  values.

### 1.7 PERFORMANCE OF THE TEST

#### 1.7.1 **Conditions of exposure**

##### 1.7.1.1 *Treatment and control*

If agrochemicals are tested, the soil is divided into three portions of equal weight. Two portions are mixed with the carrier containing the product, and the other is mixed with the carrier without the product (control). A minimum of three replicates for both treated and untreated soils is recommended. If non-agrochemicals are tested, the soil is divided into six portions of equal weight. Five of the samples are mixed with the carrier containing the test substance, and the sixth sample is mixed with the carrier without the chemical. Three replicates for both treatments and control are recommended. Care should be taken to ensure homogeneous distribution of the test substance in the treated soil samples. During mixing, compacting or balling of the soil should be avoided.

##### 1.7.1.2 *Incubation of soil samples*

Incubation of soil samples can be performed in two ways: as bulk samples of each treated and untreated soil or as a series of individual and equally sized subsamples of each treated and untreated soil. However, when volatile substances are tested, the test should only be performed with a series of individual subsamples. When soils are incubated in bulk, large quantities of each treated and untreated soils are prepared and subsamples to be analysed are taken as needed during the test. The amount initially prepared for each treatment and control depends on the size of the subsamples, the number of replicates used for analysis and the anticipated maximum number of sampling times. Soils incubated in bulk should be thoroughly mixed before subsampling. When soils are incubated as a series of individual soil samples, each treated and untreated bulk soil is divided into the required number of subsamples, and these are utilised as needed. In the experiments where more than two sampling times can be anticipated, enough subsamples should be prepared to account for all replicates and all sampling times. At least three replicate samples of the test soil should be incubated under aerobic conditions (see section 1.7.1.1). During all tests, appropriate containers with sufficient headspace should be used to avoid development of anaerobic conditions. When volatile substances are tested, the test should only be performed with a series of individual subsamples.

### 1.7.1.3 *Test conditions and duration*

The test is carried out in the dark at room temperature of  $20 \pm 2^\circ\text{C}$ . The moisture content of soil samples should be maintained during the test between 40 % and 60 % of the maximum water holding capacity of the soil (see section 1.6.4.2) with a range of  $\pm 5$  %. Distilled, deionised water can be added as needed.

The minimum duration of tests is 28 days. If agrochemicals are tested, the quantities of carbon dioxide released or oxygen consumed in treated and control samples are compared. If these differ by more than 25 % on day 28, the test is continued until a difference equal to or less than 25 % is obtained, or for a maximum of 100 days, whichever is shorter. If non-agrochemicals are tested, the test is terminated after 28 days. On day 28, the quantities of carbon dioxide released or oxygen consumed in treated and control soil samples are determined and the  $\text{EC}_x$  values are calculated.

## 1.7.2 **Sampling and analysis of soils**

### 1.7.2.1 *Soil sampling schedule*

If agrochemicals are tested, soil samples are analysed for glucose-induced respiration rates on days 0, 7, 14 and 28. If a prolonged test is required, further measurements should be made at 14 days intervals after day 28.

If non-agrochemicals are tested, at least five test concentrations are used and soil samples are analysed for glucose-induced respiration at the beginning (day 0) and at the end of the exposure period (28 days). An intermediate measurement, e.g. at day 7, may be added if deemed necessary. The data obtained on day 28 are used to determine  $\text{EC}_x$  value for the chemical. If desired, data from day 0 control samples can be used to estimate the initial quantities of metabolically active microbial biomass in the soil (12).

### 1.7.2.2 *Measurement of glucose-induced respiration rates*

The glucose-induced respiration rate in each treated and control replicate is determined at each sampling time. The soil samples are mixed with a sufficient amount of glucose to elicit an immediate maximum respiratory response. The amount of glucose needed to elicit a maximum respiratory response from a given soil can be determined in a preliminary test using a series of concentrations of glucose (14). However, for sandy soils with 0.5-1.5 % organic carbon, 2 000 mg to 2 000 mg glucose per kg dry weight soil is usually sufficient. The glucose can be ground to a powder with clean quartz sand (10 g sand/kg dry weight soil) and homogeneously mixed with the soil.

The glucose amended soil samples are incubated in a suitable apparatus for measurement of respiration rates either continuously, every hour, or every two hours (see section 1.6.1) at  $20 \pm 2^\circ\text{C}$ . The carbon dioxide released or the oxygen consumed is measured for 12 consecutive hours and measurements should start as soon as possible, i.e. within 1 to 2 hours after glucose supplement. The total quantities of carbon dioxide released or oxygen consumed during the 12 hours are measured and mean respiration rates are determined.

## 2. **DATA**

### 2.1 **TREATMENT OF RESULTS**

If agrochemicals are tested, the carbon dioxide released from, or oxygen consumed by each replicate soil sample should be recorded, and the mean values of all replicates should be provided in tabular form. Results should be evaluated by appropriate and generally acceptable statistical methods (e.g. F-test, 5 % significance level). Glucose-induced respiration rates are expressed in mg carbon dioxide/kg dry weight soil/h or mg oxygen/dry weight soil/h. The mean carbon dioxide formation rate or mean oxygen consumption rate in each treatment is compared with that in control, and the percent deviation from the control is calculated.

If tests are conducted with non-agrochemicals, the quantities of carbon dioxide released or oxygen consumed by each replicate is determined, and a dose-response curve is prepared for estimation of the  $\text{EC}_x$

values. The glucose-induced respiration rates (i.e. mg carbon dioxide/kg dry weight soil/h or mg oxygen/dry weight soil/h) found in the treated samples after 28 days are compared to that found in control. From these data, the % inhibition values for each test concentration are calculated. These percentages are plotted against concentration, and statistical procedures are used to calculate the  $EC_x$  values. Confidence limits ( $p = 0.95$ ) for the calculated  $EC_x$  are also determined using standard procedures (15)(16)(17).

## 2.2 INTERPRETATION OF RESULTS

When results from tests with agrochemicals are evaluated, and the difference in respiration rates between the lower treatment (i.e. the maximum predicted concentration) and control is equal to or less than 25 % at any sampling time after day 28, the product can be evaluated as having no long-term influence on carbon transformation in soils. When results from tests with chemicals other than agrochemicals are evaluated, the  $EC_{50}$ ,  $EC_{25}$  and/or  $EC_{10}$  values are used.

## 3. REPORTING

### 3.1 TEST REPORT

The test report must include the following information:

Complete identification of the soil used including:

- geographical reference of the site (latitude, longitude);
- information on the history of the site (i.e. vegetation cover, treatments with crop protection products, treatments with fertilisers, accidental contamination, etc.);
- use pattern (e.g. agricultural soil, forest, etc.);
- depth of sampling (cm);
- sand/silt/clay content (% dry weight);
- pH (in water);
- organic carbon content (% dry weight);
- nitrogen content (% dry weight);
- cation exchange capacity (mmol/kg);
- initial microbial biomass in terms of percentage of the total organic carbon;
- reference of the methods used for the determination of each parameter;
- all information relating to the collection and storage of soil samples;
- details of pre-incubation of soil if any.

Test substance:

- physical nature and, where relevant, physical-chemical properties;
- chemical identification data, where relevant, including structural formula, purity (i.e. for crop protection products the percentage of active ingredient), nitrogen content.

Test conditions:

- details of the amendment of soil with organic substrate;
- number of concentrations of test chemical used and, where appropriate, justification of the selected concentrations;

- details of the application of test substance to soil;
- incubation temperature;
- soil moisture content at the beginning and during the test;
- method of soil incubation used (i.e. as bulk or as a series of individual subsamples);
- number of replicates;
- sampling times.

Results:

- method and equipment used for measurement of respiration rates;
- tabulated data including individual and mean values for quantities of carbon dioxide or oxygen;
- variation between the replicates in treated and control samples;
- explanations of corrections made in the calculations, if relevant;
- the percent variation of glucose-induced respiration rates at each sampling time or, if appropriate, the EC<sub>50</sub> with 95 per cent confidence limit, other EC<sub>x</sub> (i.e. EC<sub>25</sub> or EC<sub>10</sub>) with confidence intervals, and a graph of the dose-response curve;
- statistical treatment of results, where appropriate;
- all information and observations helpful for the interpretation of the results.

4. REFERENCES

- (1) EPPO (1994). Decision-Making Scheme for the Environmental Risk Assessment of Plant Protection Chemicals. Chapter 7: Soil Microflora. EPPO Bulletin 24: 1-16, 1994.
- (2) BBA (1990). Effects on the Activity of the Soil Microflora. BBA Guidelines for the Official Testing of Plant Protection Products, VI, 1-1 (2nd eds., 1990).
- (3) EPA (1987). Soil Microbial Community Toxicity Test. EPA 40 CFR Part 797.3700. Toxic Substances Control Act Test Guidelines; Proposed rule. September 28, 1987.
- (4) SETAC-Europe (1995). Procedures for assessing the environmental fate and ecotoxicity of pesticides, Ed. M.R. Lynch, Pub. SETAC-Europe, Brussels.
- (5) OECD (1995). Final Report of the OECD Workshop on Selection of Soils/Sediments, Belgirate, Italy, 18-20 January 1995.
- (6) ISO 10381-6 (1993). Soil quality - Sampling. Guidance on the collection, handling and storage of soil for the assessment of aerobic microbial processes in the laboratory.
- (7) Anderson, J.P.E. (1987). Handling and Storage of Soils for Pesticide Experiments, in "Pesticide Effects on Soil Microflora,.. Eds. L. Somerville and M.P. Greaves, Chap. 3: 45-60.
- (8) Anderson, J.P.E. (1982). Soil Respiration, in "Methods of Soil Analysis - Part 2: Chemical and Microbiological Properties,.. Agronomy Monograph N° 9. Eds. A.L. Page, R.H. Miller and D.R. Keeney. 41: 831- 871.
- (9) ISO 11266-1. (1993). Soil Quality - Guidance on Laboratory Tests for Biodegradation in Soil: Part 1. Aerobic Conditions.
- (10) ISO 14239 (1997E). Soil Quality - Laboratory incubation systems for measuring the mineralization of organic chemicals in soil under aerobic conditions.

- (11) Heinemeyer O., Insam, H., Kaiser, E.A, and Walenzik, G. (1989). Soil microbial biomass and respiration measurements; an automated technique based on infrared gas analyses. *Plant and Soil*, 116: 77-81.
- (12) ISO 14240-1 (1997). Soil quality - Determination of soil microbial biomass - Part 1: Substrate-induced respiration method.
- (13) ISO 14240-2 (1997). Soil quality - Determination of soil microbial biomass - Part 2: Fumigation-extraction method.
- (14) Malkomes, H.-P. (1986). Einfluß von Glukosemenge auf die Reaktion der Kurzzeit-Atmung im Boden Gegenüber Pflanzenschutzmitteln, Dargestellt am Beispiel eines Herbizide. (Influence of the Amount of Glucose Added to the Soil on the Effect of Pesticides in Short-Term Respiration, using a Herbicide as an Example). *Nachrichtenbl. Deut. Pflanzenschutzd., Braunschweig*, 38: 113-120.
- (15) Litchfield, J.T. and Wilcoxon, F. (1949). A simplified method of evaluating dose-effect experiments. *Jour. Pharmacol. and Exper. Ther.*, 96, 99-113.
- (16) Finney, D.J. (1971). *Probit Analysis*. 3rd ed., Cambridge, London and New-York.
- (17) Finney D.J. (1978). *Statistical Methods in biological Assay*. Griffin, Weycombe, UK.

## C.23. AEROBIC AND ANAEROBIC TRANSFORMATION IN SOIL

## 1. METHOD

This Test Method is a replicate of the OECD TG 307 (2002)

## 1.1 INTRODUCTION

This Test Method is based on existing guidelines (1)(2)(3)(4)(5)(6)(7)(8)(9). The method described in this Test Method is designed for evaluating aerobic and anaerobic transformation of chemicals in soil. The experiments are performed to determine (i) the rate of transformation of the test substance, and (ii) the nature and rates of formation and decline of transformation products to which plants and soil organisms may be exposed. Such studies are required for chemicals which are directly applied to soil or which are likely to reach the soil environment. The results of such laboratory studies can also be used to develop sampling and analysis protocols for related field studies.

Aerobic and anaerobic studies with one soil type are generally sufficient for the evaluation of transformation pathways (8)(10)(11). Rates of transformation should be determined in at least three additional soils (8)(10).

An OECD Workshop on soil and sediment selection, held at Belgirate, Italy in 1995 (10) agreed, in particular, on the number and types of soils for use in this test. The types of soils tested should be representative of the environmental conditions where use or release will occur. For example, chemicals that may be released in subtropical to tropical climates should be tested with Ferrasols or Nitosols (FAO system). The Workshop also made recommendations relating to collection, handling and storage of soil samples, based on the ISO Guidance (15). The use of paddy (rice) soils is also considered in this method.

## 1.2 DEFINITIONS

**Test substance:** any substance, whether the parent compound or relevant transformation products.

**Transformation products:** all substances resulting from biotic or abiotic transformation reactions of the test substance including CO<sub>2</sub> and products that are in bound residues.

**Bound residues:** "Bound residues" represent compounds in soil, plant or animal, which persist in the matrix in the form of the parent substance or its metabolite(s)/transformation products after extraction. The extraction method must not substantially change the compounds themselves or the structure of the matrix. The nature of the bond can be clarified in part by matrix-altering extraction methods and sophisticated analytical techniques. To date, for example, covalent ionic and sorptive bonds, as well as entrapments, have been identified in this way. In general, the formation of bound residues reduces the bioaccessibility and the bioavailability significantly (12) [modified from IUPAC 1984 (13)].

**Aerobic transformation:** reactions occurring in the presence of molecular oxygen (14).

**Anaerobic transformation:** reactions occurring under exclusion of molecular oxygen (14).

**Soil:** is a mixture of mineral and organic chemical constituents, the latter containing compounds of high carbon and nitrogen content and of high molecular weights, animated by small (mostly micro-) organisms. Soil may be handled in two states:

- (a) undisturbed, as it has developed with time, in characteristic layers of a variety of soil types;
- (b) disturbed, as it is usually found in arable fields or as occurs when samples are taken by digging and used in this test method (14).

**Mineralisation:** is the complete degradation of an organic compound to CO<sub>2</sub> and H<sub>2</sub>O under aerobic conditions, and CH<sub>4</sub>, CO<sub>2</sub> and H<sub>2</sub>O under anaerobic conditions. In the context of this test method,

when  $^{14}\text{C}$ -labelled compound is used, mineralisation means extensive degradation during which a labelled carbon atom is oxidised with release of the appropriate amount of  $^{14}\text{CO}_2$  (14).

**Half-life:**  $t_{0.5}$  is the time taken for 50 % transformation of a test substance when the transformation can be described by first-order kinetics; it is independent of the concentration.

**DT<sub>50</sub> (Disappearance Time 50):** is the time within which the concentration of the test substance is reduced by 50 %; it is different from the half-life  $t_{0.5}$  when transformation does not follow first order kinetics.

**DT<sub>75</sub> (Disappearance Time 75):** is the time within which the concentration of the test substance is reduced by 75 %.

**DT<sub>90</sub> (Disappearance Time 90):** is the time within which the concentration of the test substance is reduced by 90 %.

### 1.3 REFERENCE SUBSTANCES

Reference substances should be used for the characterisation and/or identification of transformation products by spectroscopic and chromatographic methods.

### 1.4 APPLICABILITY OF THE TEST

The method is applicable to all chemical substances (non-labelled or radiolabelled) for which an analytical method with sufficient accuracy and sensitivity is available. It is applicable to slightly volatile, non-volatile, water-soluble or water-insoluble compounds. The test should not be applied to chemicals which are highly volatile from soil (e.g. fumigants, organic solvents) and thus cannot be kept in soil under the experimental conditions of this test.

### 1.5 INFORMATION ON THE TEST SUBSTANCE

Non-labelled or labelled test substance can be used to measure the rate of transformation. Labelled material is required for studying the pathway of transformation and for establishing a mass balance.  $^{14}\text{C}$ -labelling is recommended but the use of other isotopes, such as  $^{13}\text{C}$ ,  $^{15}\text{N}$ ,  $^3\text{H}$ ,  $^{32}\text{P}$ , may also be useful. As far as possible, the label should be positioned in the most stable part(s) of the molecule <sup>(1)</sup>. The purity of the test substance should be at least 95 %.

Before carrying out a test on aerobic and anaerobic transformation in soil, the following information on the test substance should be available:

- (a) solubility in water (Method A.6)
- (b) solubility in organic solvents;
- (c) vapour pressure (Method A.4) and Henry's law constant;
- (d) n-octanol/water partition coefficient (Method A.8);
- (e) chemical stability in dark (hydrolysis) (Method C.7);
- (f)  $\text{pK}_a$  if a molecule is liable to protonation or deprotonation [OECD Guideline 112 ] (16).

Other useful information may include data on toxicity of the test substance to soil micro-organisms [Testing Methods C.21 and C.22] (16).

Analytical methods (including extraction and clean-up methods) for quantification and identification of the test substance and its transformation products should be available.

<sup>(1)</sup> For example, if the test substance contains one ring, labelling on this ring is required; if the test substance contains two or more rings, separate studies may be needed to evaluate the fate of each labelled ring and to obtain suitable information on formation of transformation products.

**1.6 PRINCIPLE OF THE TEST METHOD**

Soil samples are treated with the test substance and incubated in the dark in biometer-type flasks or in flow-through systems under controlled laboratory conditions (at constant temperature and soil moisture). After appropriate time intervals, soil samples are extracted and analysed for the parent substance and for transformation products. Volatile products are also collected for analysis using appropriate absorption devices. Using  $^{14}\text{C}$ -labelled material, the various mineralisation rates of the test substance can be measured by trapping evolved  $^{14}\text{CO}_2$  and a mass balance, including the formation of soil bound residues, can be established.

**1.7 QUALITY CRITERIA****1.7.1 Recovery**

Extraction and analysis of, at least, duplicate soil samples immediately after the addition of the test substance gives a first indication of the repeatability of the analytical method and of the uniformity of the application procedure for the test substance. Recoveries for later stages of the experiments are given by the respective mass balances. Recoveries should range from 90 % to 110 % for labelled chemicals (8) and from 70 % to 110 % for non-labelled chemicals (3).

**1.7.2 Repeatability and sensitivity of analytical method**

Repeatability of the analytical method (excluding the initial extraction efficiency) to quantify test substance and transformation products can be checked by duplicate analysis of the same extract of the soil, incubated long enough for formation of transformation products.

The limit of detection (LOD) of the analytical method for the test substance and for the transformation products should be at least  $0.01 \text{ mg}\cdot\text{kg}^{-1}$  soil (as test substance) or 1 % of applied dose whichever is lower. The limit of quantification (LOQ) should also be specified.

**1.7.3 Accuracy of transformation data**

Regression analysis of the concentrations of the test substance as a function of time gives the appropriate information on the reliability of the transformation curve and allows the calculation of the confidence limits for half-lives (in the case of pseudo first order kinetics) or  $\text{DT}_{50}$  values and, if appropriate,  $\text{DT}_{75}$  and  $\text{DT}_{90}$  values.

**1.8 DESCRIPTION OF THE TEST METHOD****1.8.1 Equipment and chemical reagents**

Incubation systems consist of static closed systems or suitable flow-through systems (7)(17). Examples of suitable flow-through soil incubation apparatus and biometer-type flask are shown in Figures 1 and 2, respectively. Both types of incubation systems have advantages and limitations (7)(17).

Standard laboratory equipment is required and especially the following:

- Analytical instruments such as GLC, HPLC, TLC-equipment, including the appropriate detection systems for analysing radiolabelled or non-labelled substances or inverse isotopes dilution method;
- Instruments for identification purposes (e.g. MS, GC-MS, HPLC-MS, NMR, etc.);
- Liquid scintillation counter;
- Oxidiser for combustion of radioactive material;
- Centrifuge;



- Extraction apparatus (for example, centrifuge tubes for cold extraction and Soxhlet apparatus for continuous extraction under reflux);
- Instrumentation for concentrating solutions and extracts (e.g. rotating evaporator);
- Water bath;
- Mechanical mixing device (e.g. kneading machine, rotating mixer).

Chemical reagents used include, for example:

- NaOH, analytical grade, 2 mol · dm<sup>-3</sup>, or other appropriate base (e.g. KOH, ethanolamine);
- H<sub>2</sub>SO<sub>4</sub>, analytical grade, 0.05 mol · dm<sup>-3</sup>;
- Ethylene glycol, analytical grade;
- Solid absorption materials such as soda lime and polyurethane plugs;
- Organic solvents, analytical grade, such as acetone, methanol, etc.;
- Scintillation liquid.

#### 1.8.2 Test substance application

For addition to and distribution in soil, the test substance can be dissolved in water (deionised or distilled) or, when necessary, in minimum amounts of acetone or other organic solvents (6) in which the test substance is sufficiently soluble and stable. However, the amount of solvent selected should not have a significant influence on soil microbial activity (see sections 1.5 and 1.9.2-1.9.3). The use of solvents which inhibit microbial activity, such as chloroform, dichloromethane and other halogenated solvents, should be avoided.

The test substance can also be added as a solid, e.g. mixed in quartz sand (6) or in a small sub-sample of the test soil which has been air-dried and sterilised. If the test substance is added using a solvent the solvent should be allowed to evaporate before the spiked sub-sample is added to the original non-sterile soil sample.

For general chemicals, whose major route of entry into soil is through sewage sludge/farming application, the test substance should be first added to sludge which is then introduced into the soil sample. (see sections 1.9.2 and 1.9.3)

The use of formulated products is not routinely recommended. However, e.g. for poorly soluble test substances, the use of formulated material may be an appropriate alternative.

#### 1.8.3 Soils

##### 1.8.3.1 Soil selection

To determine the transformation pathway, a representative soil can be used; a sandy loam or silty loam or loam or loamy sand [according to FAO and USDA classification (18)] with a pH of 5.5-8.0, an organic carbon content of 0.5-2.5 % and a microbial biomass of at least 1 % of total organic carbon is recommended (10).

For transformation rate studies at least three additional soils should be used representing a range of relevant soils. The soils should vary in their organic carbon content, pH, clay content and microbial biomass (10).

All soils should be characterised, at least, for texture (% sand, % silt, % clay) [according to FAO and USDA classification (18)], pH, cation exchange capacity, organic carbon, bulk density, water retention characteristic <sup>(2)</sup> and microbial biomass (for aerobic studies only). Additional information on soil properties may be useful in interpreting the results. For determination of the soil characteristics the

<sup>(2)</sup> Water retention characteristic of a soil can be measured as field capacity, as water holding capacity or as water suction tension (pF). For explanations see Annex 1. It should be reported in the test report whether water retention characteristics and bulk density of soils were determined in undisturbed field samples or in disturbed (processed) samples.

methods recommended in references (19)(20)(21)(22)(23) can be used. Microbial biomass should be determined by using the substrate-induced respiration (SIR) method (25)(26) or alternative methods (20).

#### 1.8.3.2 *Collection, handling, and storage of soils*

Detailed information on the history of the field site from where the test soil is collected should be available. Details include exact location, vegetation cover, treatments with chemicals, treatments with organic and inorganic fertilisers, additions of biological materials or other contamination. If soils have been treated with the test substance or its structural analogues within the previous four years, these should not be used for transformation studies (10)(15).

The soil should be freshly collected from the field (from the A horizon or top 20 cm layer) with a soil water content which facilitates sieving. For soils other than those from paddy fields, sampling should be avoided during or immediately following long periods (> 30 days) of drought, freezing or flooding (14). Samples should be transported in a manner which minimises changes in soil water content and should be kept in the dark with free access of air, as much as possible. A loosely-tied polyethylene bag is generally adequate for this purpose.

The soil should be processed as soon as possible after sampling. Vegetation, larger soil fauna and stones should be removed prior to passing the soil through a 2 mm sieve which removes small stones, fauna and plant debris. Extensive drying and crushing of the soil before sieving should be avoided (15).

When sampling in the field is difficult in winter (soil frozen or covered by layers of snow), it may be taken from a batch of soil stored in the greenhouse under plant cover (e.g. grass or grass-clover mixtures). Studies with soils freshly collected from the field are strongly preferred, but if the collected and processed soil has to be stored prior to the start of the study storage conditions must be adequate and for a limited time only ( $4 \pm 2$  °C for a maximum of three months) to maintain microbial activity <sup>(3)</sup>. Detailed instructions on collection, handling and storage of soils to be used for biotransformation experiments can be found in (8)(10)(15)(26)(27).

Before the processed soil is used for this test, it should be pre-incubated to allow germination and removal of seeds, and to re-establish equilibrium of microbial metabolism following the change from sampling or storage conditions to incubation conditions. A pre-incubation period between 2 and 28 days approximating the temperature and moisture conditions of the actual test is generally adequate (15). Storage and pre-incubation time together should not exceed three months.

### 1.9 PERFORMANCE OF THE TEST

#### 1.9.1 **Test conditions**

##### 1.9.1.1 *Test temperature*

During the whole test period, the soils should be incubated in the dark at a constant temperature representative of the climatic conditions where use or release will occur. A temperature of  $20 \pm 2$  °C is recommended for all test substances which may reach the soil in temperate climates. The temperature should be monitored.

For chemicals applied or released in colder climates (e.g. in northern countries, during autumn/winter periods), additional soil samples should be incubated but at a lower temperature (e.g.  $10 \pm 2$  °C).

<sup>(3)</sup> Recent research results indicate that soils from temperate zones can also be stored at  $-20$  °C for more than three months (28)(29) without significant losses of microbial activity.

1.9.1.2 *Moisture content*

For transformation tests under aerobic conditions, the soil moisture content <sup>(4)</sup> should be adjusted to and maintained at a pF between 2.0 and 2.5 (3). The soil moisture content is expressed as mass of water per mass of dry soil and should be regularly controlled (e.g. in 2 week intervals) by weighing of the incubation flasks and water losses compensated by adding water (preferably sterile-filtered tap water). Care should be given to prevent or minimise losses of test substance and/or transformation products by volatilisation and/or photodegradation (if any) during moisture addition.

For transformation tests under anaerobic and paddy conditions, the soil is water-saturated by flooding.

1.9.1.3 *Aerobic incubation conditions*

In the flow-through systems, aerobic conditions will be maintained by intermittent flushing or by continuously ventilating with humidified air. In the biometer flasks, exchange of air is maintained by diffusion.

1.9.1.4 *Sterile aerobic conditions*

To obtain information on the relevance of abiotic transformation of a test substance, soil samples may be sterilised (for sterilisation methods see references 16 and 29), treated with sterile test substance (e.g. addition of solution through a sterile filter) and aerated with humidified sterile air as described in section 1.9.1.3. For paddy soils, soil and water should be sterilised and the incubation should be carried out as described in section 1.9.1.6.

1.9.1.5 *Anaerobic incubation conditions*

To establish and maintain anaerobic conditions, the soil treated with the test substance and incubated under aerobic conditions for 30 days or one half-life or DT<sub>50</sub> (whichever is shorter) is then water-logged (1-3 cm water layer) and the incubation system flushed with an inert gas (e.g. nitrogen or argon) <sup>(5)</sup>. The test system must allow for measurements such as pH, oxygen concentration and redox potential and include trapping devices for volatile products. The biometer-type system must be closed to avoid entrance of air by diffusion.

1.9.1.6 *Paddy incubation conditions*

To study transformation in paddy rice soils, the soil is flooded with a water layer of about 1-5 cm and the test substance applied to the water phase (9). A soil depth of at least 5 cm is recommended. The system is ventilated with air as under aerobic conditions. pH, oxygen concentration and redox potential of the aqueous layer should be monitored and reported. A pre-incubation period of at least two weeks is necessary before commencing transformation studies (see section 1.8.3.2).

1.9.1.7 *Test duration*

The rate and pathway studies should normally not exceed 120 days <sup>(6)</sup> (3)(6)(8), because thereafter a decrease of the soil microbial activity with time would be expected in an artificial laboratory system isolated from natural replenishment. Where necessary to characterise the decline of the test substance and the formation and decline of major transformation products, studies can be continued for longer periods (e.g. 6 or 12 months) (8). Longer incubation periods should be justified in the test report and accompanied by biomass measurements during and at the end of these periods.

<sup>(4)</sup> The soil should neither be too wet nor too dry to maintain adequate aeration and nutrition of soil microflora. Moisture contents recommended for optimal microbial growth range from 40-60 % water holding capacity (WHC) and from 0.1-0.33 bar (6). The latter range is equivalent to a pF-range of 2.0 – 2.5. Typical moisture contents of various soil types are given in Annex 2.

<sup>(5)</sup> Aerobic conditions are dominant in surface soils and even in sub-surface soils as shown in an EU sponsored research project [K. Takagi et al. (1992). Microbial diversity and activity in subsoils: Methods, field site, seasonal variation in subsoil temperatures and oxygen contents. Proc. Internat. Symp. Environm. Aspects Pesticides Microbiol., 270-277, 17-21 August 1992, Sigtuna, Sweden]. Anaerobic conditions may only occur occasionally during flooding of soils after heavy rainfalls or when paddy conditions are established in rice fields.

<sup>(6)</sup> Aerobic studies might be terminated much before 120 days provided that ultimate transformation pathway and ultimate mineralisation are clearly reached at that time. Termination of the test is possible after 120 days, or when at least 90 % of the test substance is transformed, but only if at least 5 % CO<sub>2</sub> is formed.

### 1.9.2 Performance of the test

About 50 to 200 g of soil (dry weight basis) are placed into each incubation flask (see Figures 1 and 2 in Annex 3) and the soil treated with the test substance by one of the methods described in section 1.8.2. When organic solvents are used for the application of the test substance, they should be removed from soil by evaporation. Then the soil is thoroughly mixed with a spatula and/or by shaking of the flask. If the study is conducted under paddy field conditions, soil and water should be thoroughly mixed after application of the test substance. Small aliquots (e.g. 1 g) of the treated soils should be analysed for the test substance to check for uniform distribution. For alternative method, see below.

The treatment rate should correspond to the highest application rate of a crop protection product recommended in the use instructions and uniform incorporation to an appropriate depth in the field (e.g. top 10 cm layer <sup>(7)</sup> of soil). For example, for chemicals foliarly or soil applied without incorporation, the appropriate depth for computing how much chemical should be added to each flask is 2.5 cm. For soil incorporated chemicals, the appropriate depth is the incorporation depth specified in the use instructions. For general chemicals, the application rate should be estimated based on the most relevant route of entry; for example, when the major route of entry in soil is through sewage sludge, the chemical should be dosed into the sludge at a concentration that reflects the expected sludge concentration and the amount of sludge added to the soil should reflect normal sludge loading to agricultural soils. If this concentration is not high enough to identify major transformation products, incubation of separate soil samples containing higher rates may be helpful, but excessive rates influencing soil microbial functions should be avoided (see sections 1.5 and 1.8.2).

Alternatively, a larger batch (i.e. 1 to 2 kg) of soil can be treated with the test substance, carefully mixed in an appropriate mixing machine and then transferred in small portions of 50 to 200 g into the incubation flasks (for example with the use of sample splitters). Small aliquots (e.g. 1 g) of the treated soil batch should be analysed for the test substance to check for uniform distribution. Such a procedure is preferred since it allows for more uniform distribution of the test substance into the soil.

Also untreated soil samples are incubated under the same conditions (aerobic) as the samples treated with the test substance. These samples are used for biomass measurements during and at the end of the studies.

When the test substance is applied to the soil dissolved in organic solvent(s), soil samples treated with the same amount of solvent(s) are incubated under the same conditions (aerobic) as the samples treated with the test substance. These samples are used for biomass measurements initially, during and at the end of the studies to check for effects of the solvent(s) on microbial biomass.

The flasks containing the treated soil are either attached to the flow-through system described in Figure 1 or closed with the absorption column shown in Figure 2 (see Annex 3).

### 1.9.3 Sampling and measurement

Duplicate incubation flasks are removed at appropriate time intervals and the soil samples extracted with appropriate solvents of different polarity and analysed for the test substance and/or transformation products. A well-designed study includes sufficient flasks so that two flasks are sacrificed at each sampling event. Also, absorption solutions or solid absorption materials are removed at various time intervals (7-day intervals during the first month and after one month in 17-day intervals) during and at the end of incubation of each soil sample and analysed for volatile products. Besides a soil sample taken directly after

<sup>(7)</sup> Calculation of the initial concentration on an area basis using the following equation:

$$C_{\text{soil}}[\text{mg}/\text{kg}_{\text{soil}}] = \frac{A[\text{kg}/\text{ha}] \cdot 10^6[\text{mg}/\text{kg}]}{l[\text{m}] \cdot 10^4[\text{m}^2/\text{ha}] \cdot d[\text{kg}_{\text{soil}}/\text{m}^3]}$$

$C_{\text{soil}}$  = Initial concentration in soil [ $\text{mg} \cdot \text{kg}^{-1}$ ]

$A$  = Application rate [ $\text{kg} \cdot \text{ha}^{-1}$ ];  $l$  = thickness of field soil layer [ $\text{m}$ ];  $d$  = dry bulk density of soil [ $\text{kg} \cdot \text{m}^{-3}$ ].

As a rule of thumb, an application rate of  $1 \text{ kg} \cdot \text{ha}^{-1}$  results in a soil concentration of approximately  $1 \text{ mg} \cdot \text{kg}^{-1}$  in a 10 cm layer (assuming a bulk density of  $1 \text{ g} \cdot \text{cm}^{-3}$ ).

application (0-day sample) at least 5 additional sampling points should be included. Time intervals should be chosen in such a way that pattern of decline of the test substance and patterns of formation and decline of transformation products can be established (e.g. 0, 1, 3, 7 days; 2, 3 weeks; 1, 2, 3 months, etc.).

When using  $^{14}\text{C}$ -labelled test substance, non-extractable radioactivity will be quantified by combustion and a mass balance will be calculated for each sampling interval.

In the case of anaerobic and paddy incubation, the soil and water phases are analysed together for test substance and transformation products or separated by filtration or centrifugation before extraction and analysis.

#### 1.9.4 **Optional tests**

Aerobic, non-sterile studies at additional temperatures and soil moistures may be useful for the estimation of the influence of temperature and soil moisture on the rates of transformation of a test substance and/or its transformation products in soil.

A further characterisation of non-extractable radioactivity can be attempted using, for example, supercritical fluid extraction.

## 2. **DATA**

### 2.1 TREATMENT OF RESULTS

The amounts of test substance, transformation products, volatile substances (in % only), and non-extractable should be given as % of applied initial concentration and, where appropriate, as  $\text{mg}\cdot\text{kg}^{-1}$  soil (based on soil dry weight) for each sampling interval. A mass balance should be given in percentage of the applied initial concentration for each sampling interval. A graphical presentation of the test substance concentrations against time will allow an estimation of its transformation half-life or  $\text{DT}_{50}$ . Major transformation products should be identified and their concentrations should also be plotted against time to show their rates of formation and decline. A major transformation product is any product representing  $\geq 10\%$  of applied dose at any time during the study.

The volatile products trapped give some indication of the volatility potential of a test substance and its transformation products from soil.

More accurate determinations of half-lives or  $\text{DT}_{50}$  values and, if appropriate,  $\text{DT}_{75}$  and  $\text{DT}_{90}$  values should be obtained by applying appropriate kinetic model calculations. The half-life and  $\text{DT}_{50}$  values should be reported together with the description of the model used, the order of kinetics and the determination coefficient ( $r^2$ ). First order kinetics is favoured unless  $r^2 < 0.7$ . If appropriate, the calculations should also be applied to the major transformation products. Examples of appropriate models are described in references 31 to 35.

In the case of rate studies carried out at various temperatures, the transformation rates should be described as a function of temperature within the experimental temperature range using the Arrhenius relationship of the form:

$$k = A \cdot e^{-B/T} \quad \text{or} \quad \ln k = \ln A - \frac{B}{T},$$

where  $\ln A$  and  $B$  are regression constants from the intercept and slope, respectively, of a best fit line generated from linearly regressing  $\ln k$  against  $1/T$ ,  $k$  is the rate constant at temperature  $T$  and  $T$  is the temperature in Kelvin. Care should be given to the limited temperature range in which the Arrhenius relationship will be valid in case transformation is governed by microbial action.

### 2.2 EVALUATION AND INTERPRETATION OF RESULTS

Although the studies are carried out in an artificial laboratory system, the results will allow estimation of the rate of transformation of the test substance and also of rate of formation and decline of transformation products under field conditions (36)(37).

A study of the transformation pathway of a test substance provides information on the way in which the applied substance is structurally changed in the soil by chemical and microbial reactions.

### 3. REPORTING

#### 3.1 TEST REPORT

The test report must include:

Test substance:

- common name, chemical name, CAS number, structural formula (indicating position of label(s) when radiolabelled material is used) and relevant physical-chemical properties (see section 1.5);
- purity (impurities) of test substance;
- radiochemical purity of labelled chemical and specific activity (where appropriate);

Reference substances:

- chemical name and structure of reference substances used for the characterisation and/or identification of transformation product;

Test soils:

- details of collection site;
- date and procedure of soil sampling;
- properties of soils, such as pH, organic carbon content, texture (% sand, % silt, % clay), cation exchange capacity, bulk density, water retention characteristic, and microbial biomass;
- length of soil storage and storage conditions (if stored);

Test conditions:

- dates of the performance of the studies;
- amount of test substance applied;
- solvents used and method of application for the test substance;
- weight of soil treated initially and sampled at each interval for analysis;
- description of the incubation system used;
- air flow rates (for flow-through systems only);
- temperature of experimental set-up;
- soil moisture content during incubation;
- microbial biomass initially, during and at the end of the aerobic studies;
- pH, oxygen concentration and redox potential initially, during and at the end of the anaerobic and paddy studies;
- method(s) of extraction;
- methods for quantification and identification of the test substance and major transformation products in soil and absorption materials;
- number of replicates and number of controls.

## Results:

- result of microbial activity determination;
- repeatability and sensitivity of the analytical methods used;
- rates of recovery (% values for a valid study are given in section 1.7.1);
- tables of results expressed as % of applied initial dose and, where appropriate, as  $\text{mg}\cdot\text{kg}^{-1}$  soil (on a dry weight basis);
- mass balance during and at the end of the studies;
- characterisation of non-extractable (bound) radioactivity or residues in soil;
- quantification of released  $\text{CO}_2$  and other volatile compounds;
- plots of soil concentrations versus time for the test substance and, where appropriate, for major transformation products;
- half-life or  $\text{DT}_{50}$ ,  $\text{DT}_{75}$  and  $\text{DT}_{90}$  for the test substance and, where appropriate, for major transformation products including confidence limits;
- estimation of abiotic degradation rate under sterile conditions;
- an assessment of transformation kinetics for the test substance and, where appropriate, for major transformation products;
- proposed pathways of transformation, where appropriate;
- discussion and interpretation of results;
- raw data (i.e. sample chromatograms, sample calculations of transformation rates and means used to identify transformation products).

#### 4. REFERENCES

- (1) US- Environmental Protection Agency (1982). Pesticide Assessment Guidelines, Subdivision N. Chemistry: Environmental Fate.
- (2) Agriculture Canada (1987). Environmental Chemistry and Fate. Guidelines for registration of pesticides in Canada.
- (3) European Union (EU) (1995). Commission Directive 95/36/EC of 14 July 1995 amending Council Directive 91/414/EEC concerning the placing of plant protection products on the market. Annex II, Part A and Annex III, Part A: Fate and Behaviour in the Environment.
- (4) Dutch Commission for Registration of Pesticides (1995). Application for registration of a pesticide. Section G: Behaviour of the product and its metabolites in soil, water and air.
- (5) BBA (1986). Richtlinie für die amtliche Prüfung von Pflanzenschutzmitteln, Teil IV, 4-1. Verbleib von Pflanzenschutzmitteln im Boden - Abbau, Umwandlung und Metabolismus.
- (6) ISO/DIS 11266-1 (1994). Soil Quality -Guidance on laboratory tests for biodegradation of organic chemicals in soil - Part 1 : Aerobic conditions.
- (7) ISO 14239 (1997). Soil Quality – Laboratory incubation systems for measuring the mineralization of organic chemicals in soil under aerobic conditions.
- (8) SETAC (1995). Procedures for Assessing the Environmental Fate and Ecotoxicity of Pesticides. Mark R. Lynch, Ed.
- (9) MAFF - Japan 2000 - Draft Guidelines for transformation studies of pesticides in soil - Aerobic metabolism study in soil under paddy field conditions (flooded).

- (10) OECD (1995). Final Report of the OECD Workshop on Selection of Soils/Sediments. Belgirate, Italy, 18-20 January 1995.
- (11) Guth, J.A. (1980). The study of transformations. In Interactions between Herbicides and the Soil (R.J. Hance, Ed.), Academic Press, 123-157.
- (12) DFG: Pesticide Bound Residues in Soil. Wiley – VCH (1998).
- (13) T.R. Roberts: Non-extractable pesticide residue in soils and plants. Pure Appl. Chem. 56, 945-956 (IUPAC 1984).
- (14) OECD Test Guideline 304 A: Inherent Biodegradability in Soil (adopted 12 May 1981).
- (15) ISO 10381-6 (1993). Soil Quality - Sampling - Part 6: Guidance on the collection, handling and storage of soil for the assessment of aerobic microbial processes in the laboratory.
- (16) Annex V to Dir. 67/548/EEC.
- (17) Guth, J.A. (1981). Experimental approaches to studying the fate of pesticides in soil. In Progress in Pesticide Biochemistry. D.H. Hutson, T.R. Roberts, Eds. J. Wiley & Sons. Vol 1, 85-114.
- (18) Soil Texture Classification (US and FAO systems): Weed Science, 33, Suppl. 1 (1985) and Soil Sci. Soc. Amer. Proc. 26:305 (1962).
- (19) Methods of Soil Analysis (1986). Part 1, Physical and Mineralogical Methods. A. Klute, Ed.) Agronomy Series No 9, 2nd Edition.
- (20) Methods of Soil Analysis (1982). Part 2, Chemical and Microbiological Properties. A.L. Page, R.H. Miller and D.R. Kelney, Eds. Agronomy Series No 9, 2nd Edition.
- (21) ISO Standard Compendium Environment (1994). Soil Quality - General aspects; chemical and physical methods of analysis; biological methods of analysis. First Edition.
- (22) Mückenhausen, E. (1975). Die Bodenkunde und ihre geologischen, geomorphologischen, mineralogischen und petrologischen Grundlagen. DLG-Verlag, Frankfurt, Main.
- (23) Scheffer, F., Schachtschabel, P. (1975). Lehrbuch der Bodenkunde. F. Enke Verlag, Stuttgart.
- (24) Anderson, J.P.E., Domsch, K.H. (1978) A physiological method for the quantitative measurement of microbial biomass in soils. Soil Biol. Biochem. 10, 215-221.
- (25) ISO 14240-1 and 2 (1997). Soil Quality - Determination of soil microbial biomass - Part 1: Substrate-induced respiration method. Part 2: fumigation-extraction method.
- (26) Anderson, J.P.E. (1987). Handling and storage of soils for pesticide experiments. In Pesticide Effects on Soil Microflora. L. Somerville, M.P. Greaves, Eds. Taylor & Francis, 45-60.
- (27) Kato, Yasuhiro. (1998). Mechanism of pesticide transformation in the environment: Aerobic and bio-transformation of pesticides in aqueous environment. Proceedings of the 16<sup>th</sup> Symposium on Environmental Science of Pesticide, 105-120.
- (28) Keuken O., Anderson J.P.E. (1996). Influence of storage on biochemical processes in soil. In Pesticides, Soil Microbiology and Soil Quality, 59-63 (SETAC-Europe).
- (29) Stenberg B., Johansson M., Pell M., Sjö Dahl-Svensson K., Stenström J., Torstensson L. (1996). Effect of freeze and cold storage of soil on microbial activities and biomass. In Pesticides, Soil Microbiology and Soil Quality, 68-69 (SETAC-Europe).
- (30) Gennari, M., Negre, M., Ambrosoli, R. (1987). Effects of ethylene oxide on soil microbial content and some chemical characteristics. Plant and Soil 102, 197-200.



- (31) Anderson, J.P.E. (1975). Einfluss von Temperatur und Feuchte auf Verdampfung, Abbau und Festlegung von Diallyl im Boden. Z. PflKrankh Pflschutz, Sonderheft VII, 141-146.
  - (32) Hamaker, J.W. (1976). The application of mathematical modelling to the soil persistence and accumulation of pesticides. Proc. BCPC Symposium: Persistence of Insecticides and Herbicides, 181-199.
  - (33) Goring, C.A.I., Laskowski, D.A., Hamaker, J.W., Meikle, R.W. (1975). Principles of pesticide degradation in soil. In "Environmental Dynamics of Pesticides". R. Haque and V.H. Freed, Eds., 135-172.
  - (34) Timme, G., Frehse, H., Laska, V. (1986). Statistical interpretation and graphic representation of the degradational behaviour of pesticide residues. II. Pflanzenschutz - Nachrichten Bayer 39, 188-204.
  - (35) Timme, G., Frehse, H. (1980). Statistical interpretation and graphic representation of the degradational behaviour of pesticide residues. I. Pflanzenschutz - Nachrichten Bayer 33, 47-60.
  - (36) Gustafson D.I., Holden L.R. (1990). Non-linear pesticide dissipation in soil; a new model based on spatial variability. Environm. Sci. Technol. 24, 1032-1041.
  - (37) Hurle K., Walker A. (1980). Persistence and its prediction. In Interactions between Herbicides and the Soil (R.J. Hance, Ed.), Academic Press, 83-122.
-

## ANNEX 1

WATER TENSION, FIELD CAPACITY (FC) AND WATER HOLDING CAPACITY (WHC) <sup>(1)</sup>

| Height of Water Column [cm] | pF <sup>(a)</sup> | bar <sup>(b)</sup>  | Remarks                                  |
|-----------------------------|-------------------|---------------------|--|
| 10 <sup>7</sup>             | 7                 | 10 <sup>4</sup>     | Dry Soil                                 |
| 1,6 · 10 <sup>4</sup>       | 4,2               | 16                  | Wilting point                            |
| 10 <sup>4</sup>             | 4                 | 10                  |  |
| 10 <sup>3</sup>             | 3                 | 1                   |  |
| 6 · 10 <sup>2</sup>         | 2,8               | 0,6                 |  |
| 3,3 · 10 <sup>2</sup>       | 2,5               | 0,33 <sup>(c)</sup> |  |
| 10 <sup>2</sup>             | 2                 | 0,1                 | } Range of Field capacity <sup>(d)</sup> |
| 60                          | 1,8               | 0,06                |  |
| 33                          | 1,5               | 0,033               |  |
| 10                          | 1                 | 0,01                | WHC (approximation)                      |
| 1                           | 0                 | 0,001               | Water saturated soil                     |

<sup>(a)</sup> pF = log of cm water column.

<sup>(b)</sup> 1 bar = 10<sup>5</sup> Pa.

<sup>(c)</sup> Corresponds to an approximate water content of 10 % in sand, 35 % in loam and 45 % in clay.

<sup>(d)</sup> Field capacity is not constant but varies with soil type between pF 1.5 and 2.5.

*Water tension* is measured in cm water column or in bar. Due to the large range of suction tension it is expressed simply as pF value which is equivalent to the logarithm of cm water column.

*Field capacity* is defined as the amount of water which can be stored against gravity by a natural soil 2 days after a longer raining period or after sufficient irrigation. It is determined in undisturbed soil in situ in the field. The measurement is thus not applicable to disturbed laboratory soil samples. FC values determined in disturbed soils may show great systematic variances.

*Water holding capacity* (WHC) is determined in the laboratory with undisturbed and disturbed soil by saturating a soil column with water by capillary transport. It is particularly useful for disturbed soils and can be up to 30 % greater than field capacity (1). It is also experimentally easier to determine than reliable FC-values.

<sup>(1)</sup> Mückenhausen, E. (1975). Die Bodenkunde und ihre geologischen, geomorphologischen, mineralogischen und petrologischen Grundlagen. DLG-Verlag, Frankfurt, Main.

## ANNEX 2

## SOIL MOISTURE CONTENTS (g water per 100 g dry soil) OF VARIOUS SOIL TYPES FROM VARIOUS COUNTRIES

| Soil Moisture | Content at  | Soil Type Country  |          |          |
|---------------|-------------|--------------------|----------|----------|
|               |             | WHC <sup>(1)</sup> | pF = 1,8 | pF = 2,5 |
| Sand          | Germany     | 28,7               | 8,8      | 3,9      |
| Loamy sand    | Germany     | 50,4               | 17,9     | 12,1     |
| Loamy sand    | Switzerland | 44,0               | 35,3     | 9,2      |
| Silt loam     | Switzerland | 72,8               | 56,6     | 28,4     |
| Clay loam     | Brazil      | 69,7               | 38,4     | 27,3     |
| Clay loam     | Japan       | 74,4               | 57,8     | 31,4     |
| Sandy loam    | Japan       | 82,4               | 59,2     | 36,0     |
| Silt loam     | USA         | 47,2               | 33,2     | 18,8     |
| Sandy loam    | USA         | 40,4               | 25,2     | 13,3     |

<sup>(1)</sup> Water Holding Capacity

## ANNEX 3

Figure 1

## Example of a flow-through apparatus to study transformation of chemicals in soil (1)(2)

- 1: needle valve
- 2: gas washing bottle containing water
- 3: ultramembrane (sterile conditions only), pore size 0.2  $\mu\text{m}$
- 4: soil metabolism flask (water-logged only for anaerobic and paddy conditions;)
- 5: ethylene glycol trap for organic volatile compounds
- 6: sulphuric acid trap for alkaline volatile compounds
- 7, 8: sodium hydroxide trap for  $\text{CO}_2$  & other acidic volatiles
- 9: flow meter.

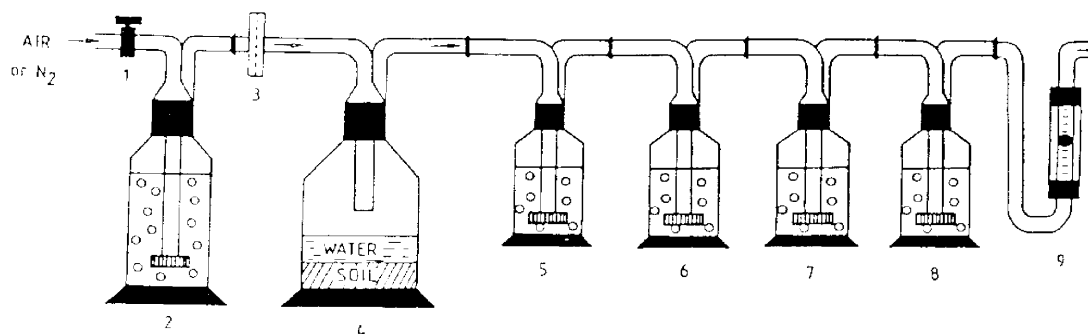
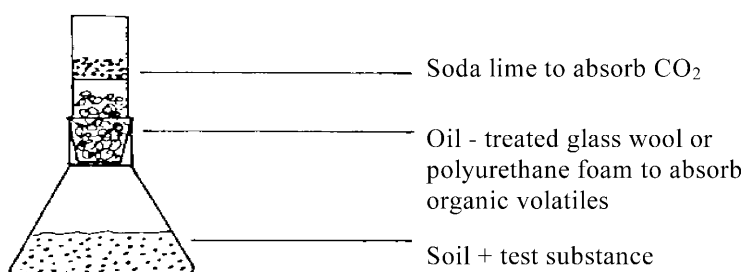

Figure 2

## Example of a biometer-type flask for studying the transformation of chemicals in soil (3)



- (1) Guth, J.A. (1980). The study of transformations. In *Interactions between Herbicides and the Soil* (R.J. Hance, Ed.), Academic Press, 123-157.
- (2) Guth, J.A. (1981). Experimental approaches to studying the fate of pesticides in soil. In *Progress in Pesticide Biochemistry*. D.H. Hutson, T.R. Roberts, Eds. J. Wiley & Sons. Vol 1, 85-114.
- (3) Anderson, J.P.E. (1975). Einfluss von Temperatur und Feuchte auf Verdampfung, Abbau und Festlegung von Diallat im Boden. *Z. PflKrankh Pflschutz, Sonderheft VII*, 141-146.

## C.24. AEROBIC AND ANAEROBIC TRANSFORMATION IN AQUATIC SEDIMENT SYSTEMS

## 1. METHOD

This test method is a replicate of the OECD TG 308 (2002).

## 1.1 INTRODUCTION

Chemicals can enter shallow or deep surface waters by such routes as direct application, spray drift, runoff, drainage, waste disposal, industrial, domestic or agricultural effluent and atmospheric deposition. This Testing Method describes a laboratory method to assess aerobic and anaerobic transformation of organic chemicals in aquatic sediment systems. It is based on existing Guidelines (1)(2)(3)(4)(5)(6). An OECD Workshop on Soil/Sediment Selection, held in Belgirate, Italy in 1995 (7) agreed, in particular, on the number and type of sediments for use in this test. It also made recommendations relating to collection, handling and storage of sediment samples, based on the ISO Guidance (8). Such studies are required for chemicals which are directly applied to water or which are likely to reach the aqueous environment by the routes described above.

The conditions in natural aquatic sediment systems are often aerobic in the upper water phase. The surface layer of sediment can be either aerobic or anaerobic, whereas the deeper sediment is usually anaerobic. To encompass all of these possibilities both aerobic and anaerobic tests are described in this document. The aerobic test simulates an aerobic water column over an aerobic sediment layer that is underlain with an anaerobic gradient. The anaerobic test simulates a completely anaerobic water-sediment system. If circumstances indicate that it is necessary to deviate significantly from these recommendations, for example by using intact sediment cores or sediments that may have been exposed to the test substance, other methods are available for this purpose (9).

## 1.2 DEFINITIONS

Standard International (SI) units should be used in any case.

**Test substance:** any substance, whether the parent or relevant transformation products.

**Transformation products:** all substances resulting from biotic and abiotic transformation reactions of the test substance including CO<sub>2</sub> and bound residues.

**Bound residues:** "Bound residues" represent compounds in soil, plant or animal that persist in the matrix in the form of the parent substance or its metabolite(s) after extractions. The extraction method must not substantially change the compounds themselves or the structure of the matrix. The nature of the bond can be clarified in part by matrix-altering extraction methods and sophisticated analytical techniques. To date, for example, covalent ionic and sorptive bonds, as well as entrapments, have been identified in this way. In general, the formation of bound residues reduces the bioaccessibility and the bioavailability significantly (10) [modified from IUPAC 1984 (11)].

**Aerobic transformation:** (oxidising): reactions occurring in the presence of molecular oxygen (12).

**Anaerobic transformation:** (reducing): reactions occurring under exclusion of molecular oxygen (12).

**Natural waters:** are surface waters obtained from ponds, rivers, streams, etc.

**Sediment:** is a mixture of mineral and organic chemical constituents, the latter containing compounds of high carbon and nitrogen content and of high molecular masses. It is deposited by natural water and forms an interface with that water.

**Mineralisation:** is the complete degradation of an organic compound to CO<sub>2</sub>, H<sub>2</sub>O under aerobic conditions, and CH<sub>4</sub>, CO<sub>2</sub> and H<sub>2</sub>O under anaerobic conditions. In the context of this test method, when radiolabelled compound is used, mineralisation means extensive degradation of a molecule during which a labelled carbon atom is oxidised or reduced quantitatively with release of the appropriate amount of <sup>14</sup>CO<sub>2</sub> or <sup>14</sup>CH<sub>4</sub>, respectively.

**Half-life**,  $t_{0.5}$ , is the time taken for 50 % transformation of a test substance when the transformation can be described by first-order kinetics; it is independent of the initial concentration.

**DT<sub>50</sub> (Disappearance Time 50)**: is the time within which the initial concentration of the test substance is reduced by 50 %.

**DT<sub>75</sub> (Disappearance Time 75)**: is the time within which the initial concentration of the test substance is reduced by 75 %.

**DT<sub>90</sub> (Disappearance Time 90)**: is the time within which the initial concentration of the test substance is reduced by 90 %.

### 1.3 REFERENCE SUBSTANCES

Reference substances should be used for the identification and quantification of transformation products by spectroscopic and chromatographic methods.

### 1.4 INFORMATION ON THE TEST SUBSTANCE

Non-labelled or isotope-labelled test substance can be used to measure the rate of transformation although labelled material is preferred. Labelled material is required for studying the pathway of transformation and for establishing a mass balance. <sup>14</sup>C-labelling is recommended, but the use of other isotopes, such as <sup>13</sup>C, <sup>15</sup>N, <sup>3</sup>H, <sup>32</sup>P, may also be useful. As far as possible, the label should be positioned in the most stable part(s) of the molecule <sup>(1)</sup>. The chemical and/or radiochemical purity of the test substance should be at least 95 %.

Before carrying out a test, the following information about the test substance should be available:

- (a) solubility in water (Method A.6);
- (b) solubility in organic solvents;
- (c) vapour pressure (Method A.4) and Henry's Law constant;
- (d) n-octanol/water partition coefficient (Method A.8);
- (e) adsorption coefficient ( $K_d$ ,  $K_f$  or  $K_{oc}$ , where appropriate) (Method C.18);
- (f) hydrolysis (Method C.7);
- (g) dissociation constant ( $pK_a$ ) [OECD Guideline 112] (13);
- (h) chemical structure of the test substance and position of the isotope-label(s), if applicable.

*Note:* The temperature at which these measurements were made should be reported.

Other useful information may include data on toxicity of the test substance to microorganisms, data on ready and/or inherent biodegradability, and data on aerobic and anaerobic transformation in soil.

Analytical methods (including extraction and clean-up methods) for identification and quantification of the test substance and its transformation products in water and in sediment should be available (see section 1.7.2).

### 1.5 PRINCIPLE OF THE TEST METHOD

The method described in this test employs an aerobic and an anaerobic aquatic sediment (see Annex 1) system which allows:

- (i) the measurement of the transformation rate of the test substance in a water-sediment system,
- (ii) the measurement of the transformation rate of the test substance in the sediment,

<sup>(1)</sup> For example, if the substance contains one ring, labelling on this ring is required; if the test substance contains two or more rings, separate studies may be needed to evaluate the fate of each labelled ring and to obtain suitable information on formation of transformation products.

- (iii) the measurement of the mineralisation rate of the test substance and /or its transformation products (when  $^{14}\text{C}$ -labelled test substance is used),
- (iv) the identification and quantification of transformation products in water and sediment phases including mass balance (when labelled test substance is used),
- (v) the measurement of the distribution of the test substance and its transformation products between the two phases during a period of incubation in the dark (to avoid, for example, algal blooms) at constant temperature. Half-lives,  $\text{DT}_{50}$ ,  $\text{DT}_{75}$  and  $\text{DT}_{90}$  values are determined where the data warrant, but should not be extrapolated far past the experimental period (see section 1.2).

At least two sediments and their associated waters are required for both the aerobic and the anaerobic studies respectively (7). However, there may be cases where more than two aquatic sediments should be used, for example, for a chemical that may be present in freshwater and/or marine environments.

## 1.6 APPLICABILITY OF THE TEST

The method is generally applicable to chemical substances (unlabelled or labelled) for which an analytical method with sufficient accuracy and sensitivity is available. It is applicable to slightly volatile, non-volatile, water-soluble or poorly water-soluble compounds. The test should not be applied to chemicals which are highly volatile from water (e.g. fumigants, organic solvents) and thus cannot be kept in water and/or sediment under the experimental conditions of this test.

The method has been applied so far to study the transformation of chemicals in fresh waters and sediments, but in principle can also be applied to estuarine/marine systems. It is not suitable to simulate conditions in flowing water (e.g. rivers) or the open sea.

## 1.7 QUALITY CRITERIA

### 1.7.1 Recovery

Extraction and analysis of, at least, duplicate water and sediment samples immediately after the addition of the test substance gives a first indication of the repeatability of the analytical method and of the uniformity of the application procedure for the test substance. Recoveries for later stages of the experiments are given by the respective mass balances (when labelled material is used). Recoveries should range from 90 % to 110 % for labelled chemicals (6) and from 70 % to 110 % for non-labelled chemicals.

### 1.7.2 Repeatability and sensitivity of analytical method

Repeatability of the analytical method (excluding the initial extraction efficiency) to quantify test substance and transformation products can be checked by duplicate analysis of the same extract of the water or the sediment samples which were incubated sufficiently long enough for formation of transformation products.

The limit of detection (LOD) of the analytical method for the test substance and for the transformation products should be at least  $0.01 \text{ mg}\cdot\text{kg}^{-1}$  in water or sediment (as test substance) or 1 % of the initial amount applied to a test system whichever is lower. The limit of quantification (LOQ) should also be specified.

### 1.7.3 Accuracy of transformation data

Regression analysis of the concentrations of the test substance as a function of time gives the appropriate information on the accuracy of the transformation curve and allows the calculation of the confidence limits for half-lives (if pseudo first-order kinetics apply) or  $\text{DT}_{50}$  values and, if appropriate,  $\text{DT}_{75}$  and  $\text{DT}_{90}$  values.

## 1.8 DESCRIPTION OF THE METHOD

### 1.8.1 Test system and apparatus

The study should be performed in glass containers (e.g. bottles, centrifuge tubes), unless preliminary information (such as n-octanol-water partition coefficient, sorption data, etc.) indicates that the test

substance may adhere to glass, in which case an alternative material (such as Teflon) may have to be considered. Where the test substance is known to adhere to glass, it may be possible to alleviate this problem using one or more of the following methods:

- determine the mass of test substance and transformation products sorbed to glass;
- ensure a solvent wash of all glassware at the end of the test;
- use of formulated products (see also section 1.9.2);
- use an increased amount of co-solvent for addition of test substance to the system; if a co-solvent is used it should be a co-solvent that does not solvolyse the test substance.

Examples of typical test apparatus, i.e. gas flow-through and biometer-type systems, are shown in Annexes 2 and 3, respectively (14). Other useful incubation systems are described in reference 15. The design of the experimental apparatus should permit the exchange of air or nitrogen and the trapping of volatile products. The dimensions of the apparatus must be such that the requirements of the test are complied with (see section 1.9.1). Ventilation may be provided by either gentle bubbling or by passing air or nitrogen over the water surface. In the latter case gentle stirring of the water from above may be advisable for better distribution of the oxygen or nitrogen in the water. CO<sub>2</sub>-free air should not be used as this can result in increases in the pH of the water. In either case, disturbance of the sediment is undesirable and should be avoided as far as possible. Slightly volatile chemicals should be tested in a biometer-type system with gentle stirring of the water surface. Closed vessels with a headspace of either atmospheric air or nitrogen and internal vials for the trapping of volatile products can also be used (16). Regular exchange of the headspace gas is required in the aerobic test in order to compensate for the oxygen consumption by the biomass.

Suitable traps for collecting volatile transformation products include but are not restricted to 1 mol·dm<sup>-3</sup> solutions of potassium hydroxide or sodium hydroxide for carbon dioxide <sup>(2)</sup> and ethylene glycol, ethanolamine or 2 % paraffin in xylene for organic compounds. Volatiles formed under anaerobic conditions, such as methane, can be collected, for example, by molecular sieves. Such volatiles can be combusted, for example, to CO<sub>2</sub> by passing the gas through a quartz tube filled with CuO at a temperature of 900 °C and trapping the CO<sub>2</sub> formed in an absorber with alkali (17).

Laboratory instrumentation for chemical analysis of test substance and transformation products is required (e.g. gas liquid chromatography (GLC), high performance liquid chromatography (HPLC), thin-layer chromatography (TLC), mass spectroscopy (MS), gas chromatography-mass spectroscopy (GC-MS), liquid chromatography-mass spectrometry (LC-MS), nuclear magnetic resonance (NMR), etc.), including detection systems for radiolabelled or non-labelled chemicals as appropriate. When radiolabelled material is used a liquid scintillation counter and combustion oxidiser (for the combustion of sediment samples prior to analysis of radioactivity) will also be required.

Other standard laboratory equipment for physical-chemical and biological determinations (see section Table 1, section 1.8.2.2), glassware, chemicals and reagents are required as appropriate.

#### 1.8.2 Selection and number of aquatic sediments

The sampling sites should be selected in accordance with the purpose of the test in any given situation. In selecting sampling sites, the history of possible agricultural, industrial or domestic inputs to the catchment and the waters upstream must be considered. Sediments should not be used if they have been contaminated with the test substance or its structural analogues within the previous 4 years.

<sup>(2)</sup> As these alkaline absorption solutions also absorb the carbon dioxide from the ventilation air and that formed by respiration in aerobic experiments, they have to be exchanged in regular intervals to avoid their saturation and thus loss of their absorption capacity.



1.8.2.1 *Sediment selection*

Two sediments are normally used for the aerobic studies (7). The two sediments selected should differ with respect to organic carbon content and texture. One sediment should have a high organic carbon content (2.5-7.5 %) and a fine texture, the other sediment should have a low organic carbon content (0.5-2.5 %) and a coarse texture. The difference between the organic carbon contents should normally be at least 2 %. 'Fine texture' is defined as a [clay + silt] <sup>(3)</sup> content of > 50 % and 'coarse texture' is defined as a [clay + silt] content of < 50 %. The difference in [clay + silt] content for the two sediments should normally be at least 20 %. In cases, where a chemical may also reach marine waters, at least one of the water-sediment systems should be of marine origin.

For the strictly anaerobic study, two sediments (including their associated waters) should be sampled from the anaerobic zones of surface water bodies (7). Both the sediment and the water phases should be handled and transported carefully under exclusion of oxygen.

Other parameters may be important in the selection of sediments and should be considered on a case-by-case basis. For example, the pH range of sediments would be important for testing chemicals for which transformation and/or sorption may be pH-dependent. pH-dependency of sorption might be reflected by the pK<sub>a</sub> of the test substance.

1.8.2.2 *Characterisation of water-sediment samples*

Key parameters that must be measured and reported (with reference to the method used) for both water and sediment, and the stage of the test at which those parameters are to be determined are summarised in the Table hereafter. For information, methods for determination of these parameters are given in references (18)(19)(20)(21).

In addition, other parameters may need to be measured and reported on a case by case basis (e.g. for freshwater: particles, alkalinity, hardness, conductivity, NO<sub>3</sub>/PO<sub>4</sub> (ratio and individual values); for sediments: cation exchange capacity, water holding capacity, carbonate, total nitrogen and phosphorus; and for marine systems: salinity). Analysis of sediments and water for nitrate, sulfate, bioavailable iron, and possibly other electron acceptors may be also useful in assessing redox conditions, especially in relation to anaerobic transformation.

**Measurement of parameters for characterisation of water-sediment samples (7)(22)(23)**

| Parameter                     | Stage of test procedure |               |                      |               |             |             |
|-------------------------------|-------------------------|---------------|----------------------|---------------|-------------|-------------|
|                               | field sampling          | post-handling | start of acclimation | start of test | during test | end of test |
| <b>Water</b>                  |                         |               |                      |               |             |             |
| Origin/source                 | x                       |               |                      |               |             |             |
| Temperature                   | x                       |               |                      |               |             |             |
| pH                            | x                       |               | x                    | x             | x           | x           |
| TOC                           |                         |               | x                    | x             |             | x           |
| O <sub>2</sub> concentration* | x                       |               | x                    | x             | x           | x           |
| Redox Potential*              |                         |               | x                    | x             | x           | x           |
| <b>Sediment</b>               |                         |               |                      |               |             |             |
| Origin/source                 | x                       |               |                      |               |             |             |
| Depth of layer                | x                       |               |                      |               |             |             |
| pH                            |                         | x             | x                    | x             | x           | x           |
| Particle size distribution    |                         | x             |                      |               |             |             |

<sup>(3)</sup> [Clay + silt] is the mineral fraction of the sediment with particle size of < 50 µm

| Parameter            | Stage of test procedure    |               |                      |               |             |             |
|----------------------|----------------------------|---------------|----------------------|---------------|-------------|-------------|
|                      | field sampling             | post-handling | start of acclimation | start of test | during test | end of test |
| TOC                  |                            | x             | x                    | x             |             | x           |
| Microbial biomass ** |                            | x             |                      | x             |             | x           |
| Redox potential *    | Observation (colour/smell) |               | x                    | x             | x           | x           |

\* Recent research results have shown that measurements of water oxygen concentrations and of redox potentials have neither a mechanistic nor a predictive value as far as growth and development of microbial populations in surface waters are concerned (24)(25). Determination of the biochemical oxygen demand (BOD, at field sampling, start and end of test) and of concentrations of micro/macro nutrients Ca, Mg and Mn (at start and end of test) in water and the measurement of total N and total P in sediments (at field sampling and end of test) may be better tools to interpret and evaluate aerobic biotransformation rates and routes.

\*\* Microbial respiration rate method (26), fumigation method (27) or plate count measurements (e.g. bacteria, actinomycetes, fungi and total colonies) for aerobic studies; methanogenesis rate for anaerobic studies.

### 1.8.3 **Collection, Handling and Storage**

#### 1.8.3.1 *Collection*

The draft ISO guidance on sampling of bottom sediment (8) should be used for sampling of sediment. Sediment samples should be taken from the entire 5 to 10 cm upper layer of the sediment. Associated water should be collected from the same site or location and at the same time as the sediment. For the anaerobic study, sediment and associated water should be sampled and transported under exclusion of oxygen (28) (see section 1.8.2.1). Some sampling devices are described in the literature (8)(23).

#### 1.8.3.2 *Handling*

The sediment is separated from the water by filtration and the sediment wet-sieved to a 2 mm-sieve using excess location water that is then discarded. Then known amounts of sediments and water are mixed at the desired ratio (see section 1.9.1) in incubation flasks and prepared for the acclimation period (see section 1.8.4). For the anaerobic study, all handling steps have to be done under exclusion of oxygen (29)(30)(31)(32)(33).

#### 1.8.3.3 *Storage*

Use of freshly sampled sediment and water is strongly recommended, but if storage is necessary, sediment and water should be sieved as described above and stored together, water-logged (6-10 cm water layer), in the dark, at  $4 \pm 2$  °C<sup>4</sup> for a maximum of 4 weeks (7)(8)(23). Samples to be used for aerobic studies should be stored with free access of air (e.g. in open containers), whereas those for anaerobic studies under exclusion of oxygen. Freezing of sediment and water and drying-out of the sediment must not occur during transportation and storage.

### 1.8.4 **Preparation of the sediment/water samples for the test**

A period of acclimation should take place prior to adding the test substance, with each sediment/water sample being placed in the incubation vessel to be used in the main test, and the acclimation to be carried out under exactly the same conditions as the test incubation (see section 1.9.1). The acclimation period is the time needed to reach reasonable stability of the system, as reflected by pH, oxygen concentration in water, redox potential of the sediment and water, and macroscopic separation of phases. The period of acclimation should normally last between one week and two weeks and should not exceed four weeks. Results of determinations performed during this period should be reported.

## 1.9 PERFORMANCE OF THE TEST

### 1.9.1 Test conditions

The test should be performed in the incubation apparatus (see section 1.8.1) with a water sediment volume ratio between 3:1 and 4:1, and a sediment layer of 2.5 cm ( $\pm 0.5$  cm)<sup>(4)</sup>. A minimum amount of 50 g of sediment (dry weight basis) per incubation vessel is recommended.

The test should be performed in the dark at a constant temperature in the range of 10 to 30 °C. A temperature of  $(20 \pm 2)$  °C is appropriate. Where appropriate, an additional lower temperature (e.g. 10 °C) may be considered on a case-by-case basis, depending on the information required from the test. Incubation temperature should be monitored and reported.

### 1.9.2 Treatment and application of test substance

One test concentration of chemical is used<sup>(5)</sup>. For crop protection chemicals applied directly to water bodies, the maximum dosage on the label should be taken as, the maximum application rate calculated on the basis of the surface area of the water in the test vessel. In all other cases, the concentration to be used should be based on predictions from environmental emissions. Care must be taken to ensure that an adequate concentration of test substance is applied in order to characterise the route of transformation and the formation and decline of transformation products. It may be necessary to apply higher doses (e.g. 10 times) in situations where test substance concentrations are close to limits of detection at the start of the study and/or where major transformation products could not readily be detected when present at 10 % of the test substance application rate. However, if higher test concentrations are used they should not have a significant adverse effect on the microbial activity of the water-sediment system. In order to achieve a constant concentration of test substance in vessels of differing dimensions an adjustment to the quantity of the material applied may be considered appropriate, based on the depth of the water column in the vessel in relation to the depth of water in the field (which is assumed to be 100 cm, but other depths can be used). See Annex 4 for an example calculation.

Ideally the test substance should be applied as an aqueous solution into the water phase of the test system. If unavoidable, the use of low amounts of water miscible solvents (such as acetone, ethanol) is permitted for application and distribution of the test substance, but this should not exceed 1 % v/v and should not have adverse effects on microbial activity of the test system. Care should be exercised in generating the aqueous solution of the test substance - use of generator columns and pre-mixing may be appropriate to ensure complete homogeneity. Following addition of the aqueous solution to the test system, gentle mixing of the water phase is recommended, disturbing the sediment as little as possible.

The use of formulated products is not routinely recommended as the formulation ingredients may affect the distribution of the test substance and/or transformation products between water and sediment phases. However, for poorly water-soluble test substances, the use of formulated material may be an appropriate alternative.

The number of incubation vessels depends on the number of sampling times (see section 1.9.3). A sufficient number of test systems should be included so that two systems may be sacrificed at each sampling time. Where control units of each aquatic sediment system are employed, they should not be treated with the test substance. The control units can be used to determine the microbial biomass of the sediment and the total organic carbon of the water and sediment at the termination of the study. Two of the control units (i.e. one control unit of each aquatic sediment) can be used to monitor the required parameters in the sediment and water during the acclimation period (see Table in section 1.8.2.2). Two additional control units have to be included in case the test substance is applied by means of a solvent to measure adverse effects on the microbial activity of the test system.

### 1.9.3 Test duration and sampling

The duration of the experiment should normally not exceed 100 days<sup>(6)</sup>, and should continue until the degradation pathway and water/sediment distribution pattern are established or when 90 % of the test substance has dissipated by transformation and/or volatilisation. The number of sampling times should be

<sup>(4)</sup> Recent studies have shown that storage at 4 °C can lead to a decrease of the organic carbon content of the sediment which may possibly result in a decrease of microbial activity (34).

<sup>(5)</sup> Test with a second concentration can be useful for chemicals that reach surface waters by different entry routes resulting in significantly different concentrations, as long as the lower concentration can be analysed with sufficient accuracy.

at least six (including zero time), with an optional preliminary study (see section 1.9.4) being used to establish an appropriate sampling regime and the duration of the test, unless sufficient data is available on the test substance from previous studies. For hydrophobic test substances, additional sampling points during the initial period of the study may be necessary in order to determine the rate of distribution between water and sediment phases.

At appropriate sampling times, whole incubation vessels (in replicate) are removed for analysis. Sediment and overlying water are analysed separately <sup>(6)</sup>. The surface water should be carefully removed with minimum disturbance of the sediment. The extraction and characterisation of the test substance and transformation products should follow appropriate analytical procedures. Care should be taken to remove material that may have adsorbed to the incubation vessel or to interconnecting tubing used to trap volatiles.

#### 1.9.4 **Optional preliminary test**

If duration and sampling regime cannot be estimated from other relevant studies on the test substance, an optional preliminary test may be considered appropriate, which should be performed using the same test conditions proposed for the definitive study. Relevant experimental conditions and results from the preliminary test, if performed, should be briefly reported.

#### 1.9.5 **Measurements and analysis**

Concentration of the test substance and the transformation products at every sampling time in water and sediment should be measured and reported (as a concentration and as percentage of applied). In general, transformation products detected at  $\geq 10\%$  of the applied radioactivity in the total water-sediment system at any sampling time should be identified unless reasonably justified otherwise. Transformation products for which concentrations are continuously increasing during the study should also be considered for identification, even if their concentrations do not exceed the limits given above, as this may indicate persistence. The latter should be considered on a case by case basis, with justifications being provided in the report.

Results from gases/volatiles trapping systems ( $\text{CO}_2$  and others, i.e. volatile organic compounds) should be reported at each sampling time. Mineralisation rates should be reported. Non-extractable (bound) residues in sediment are to be reported at each sampling point.

## 2. **DATA**

### 2.1 TREATMENT OF RESULTS

Total mass balance or recovery (see section 1.7.1) of added radioactivity is to be calculated at every sampling time. Results should be reported as a percentage of added radioactivity. Distribution of radioactivity between water and sediment should be reported as concentrations and percentages, at every sampling time.

Half-life,  $DT_{50}$  and, if appropriate,  $DT_{75}$  and  $DT_{90}$  of the test substance should be calculated along with their confidence limits (see section 1.7.3). Information on the rate of dissipation of the test substance in the water and sediment can be obtained through the use of appropriate evaluation tools. These can range from application of pseudo-first order kinetics, empirical curve-fitting techniques which apply graphical or numerical solutions and more complex assessments using, for example, single- or multi-compartment models. Further details can be obtained from the relevant published literature (35)(36)(37).

All approaches have their strengths and weaknesses and vary considerably in complexity. An assumption of first-order kinetics may be an oversimplification of the degradation and distribution processes, but when possible gives a term (the rate constant or half-life) which is easily understood and of value in simulation modelling and calculations of predicted environmental concentrations. Empirical approaches or linear transformations can result in better fits of curves to data and therefore allow better estimation of half-lives,  $DT_{50}$  and, if appropriate,  $DT_{75}$  and  $DT_{90}$  values. The use of the derived constants, however, is limited. Compartment models can generate a number of useful constants of value in risk assessment that

<sup>(6)</sup> In cases where rapid re-oxidation of anaerobic transformation products may readily occur, anaerobic conditions should be maintained during sampling and analysis.

describe the rate of degradation in different compartments and the distribution of the chemical. They should also be used for estimation of rate constants for the formation and degradation of major transformation products. In all cases, the method chosen must be justified and the experimenter should demonstrate graphically and/or statistically the goodness of fit.

### 3. REPORTING

#### 3.1 TEST REPORT

The report must include the following information:

Test substance:

- common name, chemical name, CAS number, structural formula (indicating position of the label(s) when radiolabelled material is used) and relevant physical-chemical properties;
- purity (impurities) of test substance;
- radiochemical purity of labelled chemical and molar activity (where appropriate).

Reference substances:

- chemical name and structure of reference substances used for the characterisation and/or identification of transformation products

Test sediments and waters:

- location and description of aquatic sediment sampling site(s) including, if possible, contamination history;
- all information relating to the collection, storage (if any) and acclimation of water-sediment systems;
- characteristics of the water-sediment samples as listed in Table in section 1.8.2.2.

Test conditions:

- test system used (e.g. flow-through, biometer, way of ventilation, method of stirring, water volume, mass of sediment, thickness of both water and sediment layer, dimension of test vessels, etc.)
- application of test substance to test system: test concentration used, number of replicates and controls mode of application of test substance (e.g. use of solvent if any), etc.
- incubation temperature;
- sampling times;
- extraction methods and efficiencies as well as analytical methods and detection limits;
- methods for characterisation/identification of transformation products;
- deviations from the test protocol or test conditions during the study.

Results:

- raw data figures of representative analyses (all raw data have to be stored in the GLP-archive);
- repeatability and sensitivity of the analytical methods used;
- rates of recovery (% values for a valid study are given in section 1.7.1);
- tables of results expressed as % of the applied dose and in  $\text{mg}\cdot\text{kg}^{-1}$  in water, sediment and total system (% only) for the test substance and, if appropriate, for transformation products and non-extractable radioactivity;

- mass balance during and at the end of the studies;
- a graphical representation of the transformation in the water and sediment fractions and in total system (including mineralisation);
- mineralisation rates;
- half-life,  $DT_{50}$  and, if appropriate,  $DT_{75}$  and  $DT_{90}$  values for the test substance and, where appropriate, for major transformation products including confidence limits in water, sediment and in total system;
- an assessment of the transformation kinetics of the test substance and, where appropriate, the major transformation products;
- a proposed pathway of transformation, where appropriate;
- discussion of results.

## 4

**REFERENCES**

- (1) BBA-Guidelines for the examination of plant protectors in the registration process. (1990). Part IV, Section 5-1: Degradability and fate of plant protectors in the water/sediment system. Germany.
- (2) Commission for registration of pesticides: Application for registration of a pesticide. (1991). Part G. Behaviour of the product and its metabolites in soil, water and air, Section G.2.1 (a). The Netherlands.
- (3) MAFF Pesticides Safety Directorate. (1992). Preliminary guideline for the conduct of biodegradability tests on pesticides in natural sediment/water systems. Ref No SC 9046. United-Kingdom.
- (4) Agriculture Canada: Environmental chemistry and fate. (1987). Guidelines for registration of pesticides in Canada. Aquatic (Laboratory) - Anaerobic and aerobic. Canada. pp 35-37.
- (5) US-EPA: Pesticide assessment guidelines, Subdivision N. Chemistry: Environmental fate (1982). Section 162-3, Anaerobic aquatic metabolism.
- (6) SETAC-Europe publication. (1995). Procedures for assessing the environmental fate and ecotoxicity of pesticides. Ed. Dr Mark R. Lynch. SETAC-Europe, Brussels.
- (7) OECD Test Guidelines Programme. (1995). Final Report of the OECD Workshop on Selection of Soils/sediments, Belgirate, Italy, 18-20 January 1995.
- (8) ISO/DIS 5667-12. (1994). Water quality - Sampling - Part 12: Guidance on sampling of bottom sediments.
- (9) US-EPA (1998a). Sediment/water microcosm biodegradation test. Harmonised Test Guidelines (OPPTS 835.3180). EPA 712-C-98-080.
- (10) DFG: Pesticide Bound Residues in Soil. Wiley-VCH (1998).
- (11) T.R. Roberts: Non-extractable pesticide residues in soils and plants. Pure Appl. Chem. 56, 945-956 (IUPAC 1984).
- (12) OECD Test Guideline 304A: Inherent Biodegradability in Soil (adopted 12 May 1981).
- (13) OECD (1993): Guidelines for Testing of Chemicals. Paris. OECD (1994-2000): Addenda 6-11 to Guidelines for the Testing of Chemicals.
- (14) Scholz, K., Fritz R., Anderson C. and Spiteller M. (1988) Degradation of pesticides in an aquatic model ecosystem. BCPC - Pests and Diseases, 3B-4, 149-158.
- (15) Guth, J.A. (1981). Experimental approaches to studying the fate of pesticides in soil. In Progress in Pesticide Biochemistry (D.H. Hutson, T.R. Roberts, Eds.), Vol. 1, 85-114. J. Wiley & Sons.

- (16) Madsen, T., Kristensen, P. (1997). Effects of bacterial inoculation and non-ionic surfactants on degradation of polycyclic aromatic hydrocarbons in soil. *Environ. Toxicol. Chem.* 16, 631-637.
  - (17) Steber, J., Wierich, P. (1987). The anaerobic degradation of detergent range fatty alcohol ethoxylates. Studies with <sup>14</sup>C-labelled model surfactants. *Water Research* 21, 661-667.
  - (18) Black, C.A. (1965). *Methods of Soil Analysis*. Agronomy Monograph No. 9. American Society of Agronomy, Madison.
  - (19) APHA (1989). *Standard Methods for Examination of Water and Wastewater* (17<sup>th</sup> edition). American Public Health Association, American Water Works Association and Water Pollution Control Federation, Washington D.C.
  - (20) Rowell, D.L. (1994). *Soil Science Methods and Applications*. Longman.
  - (21) Light, T.S. (1972). Standard solution for redox potential measurements. *Anal. Chemistry* 44, 1038-1039.
  - (22) SETAC-Europe publication (1991). Guidance document on testing procedures for pesticides in freshwater mesocosms. From the Workshop 'A Meeting of Experts on Guidelines for Static Field Mesocosms Tests', 3-4 July 1991.
  - (23) SETAC-Europe publication. (1993). Guidance document on sediment toxicity tests and bioassays for freshwater and marine environments. From the Workshop On Sediment Toxicity Assessment (WOSTA), 8-10 November 1993. Eds.: I.R. Hill, P. Matthiessen and F. Heimbach.
  - (24) Vink, J.P.M., van der Zee, S.E.A.T.M. (1997). Pesticide biotransformation in surface waters: multivariate analyses of environmental factors at field sites. *Water Research* 31, 2858-2868.
  - (25) Vink, J.P.M., Schraa, G., van der Zee, S.E.A.T.M. (1999). Nutrient effects on microbial transformation of pesticides in nitrifying waters. *Environ. Toxicol.* 329-338.
  - (26) Anderson, T.H., Domsch, K.H. (1985). Maintenance carbon requirements of actively-metabolising microbial populations under *in-situ* conditions. *Soil Biol. Biochem.* 17, 197-203.
  - (27) ISO-14240-2. (1997). Soil quality - Determination of soil microbial biomass - Part 2: Fumigation-extraction method.
  - (28) Beelen, P. Van and F. Van Keulen. (1990), The Kinetics of the Degradation of Chloroform and Benzene in Anaerobic Sediment from the River Rhine. *Hydrobiol. Bull.* 24 (1), 13-21.
  - (29) Shelton, D.R. and Tiedje, J.M. (1984). General method for determining anaerobic biodegradation potential. *App. Environ. Microbiol.* 47, 850-857.
  - (30) Birch, R.R., Biver, C., Campagna, R., Gledhill, W.E., Pagga, U., Steber, J., Reust, H. and Bontinck, W.J. (1989). Screening of chemicals for anaerobic biodegradation. *Chemosphere* 19, 1527-1550.
  - (31) Pagga, U. and Beimborn, D.B. (1993). Anaerobic biodegradation tests for organic compounds. *Chemosphere* 27, 1499-1509.
  - (32) Nuck, B.A. and Federle, T.W. (1986). A batch test for assessing the mineralisation of <sup>14</sup>C-radiolabelled compounds under realistic anaerobic conditions. *Environ. Sci. Technol.* 30, 3597-3603.
  - (33) US-EPA (1998b). Anaerobic biodegradability of organic chemicals. Harmonised Test Guidelines (OPPTS 835.3400). EPA 712-C-98-090.
  - (34) Sijm, Haller and Schrap (1997). Influence of storage on sediment characteristics and drying sediment on sorption coefficients of organic contaminants. *Bulletin Environ. Contam. Toxicol.* 58, 961-968.
  - (35) Timme, G., Frehse H. and Laska V. (1986) Statistical interpretation and graphic representation of the degradational behaviour of pesticide residues II. *Pflanzenschutz - Nachrichten Bayer*, 39, 187-203.
  - (36) Timme, G., Frehse, H. (1980) Statistical interpretation and graphic representation of the degradational behaviour of pesticide residues I. *Pflanzenschutz - Nachrichten Bayer*, 33, 47-60.
  - (37) Carlton, R.R. and Allen, R. (1994). The use of a compartment model for evaluating the fate of pesticides in sediment/water systems. Brighton Crop Protection Conference - Pest and Diseases, pp 1349-1354.
-

## ANNEX 1

**GUIDANCE ON THE AEROBIC AND THE ANAEROBIC TEST SYSTEMS****Aerobic test system**

The aerobic test system described in this test method consists of an aerobic water layer (typical oxygen concentrations range from 7 to 10 mg·l<sup>-1</sup>) and a sediment layer, aerobic at the surface and anaerobic below the surface (typical average redox potentials ( $E_h$ ) in the anaerobic zone of the sediment range from -80 to -190 mV). Moistened air is passed over the surface of the water in each incubation unit to maintain sufficient oxygen in the head space.

**Anaerobic test system**

For the anaerobic test system, the test procedure is essentially the same as that outlined for the aerobic system with the exception that moistened nitrogen is passed above the surface of the water in each incubation unit to maintain a head space of nitrogen. The sediment and water are regarded as anaerobic once the redox potential ( $E_h$ ) is lower than -100 mV.

In the anaerobic test, assessment of mineralisation includes measurement of evolved carbon dioxide and methane.



## ANNEX 2

## EXAMPLE OF A GAS FLOW-THROUGH APPARATUS

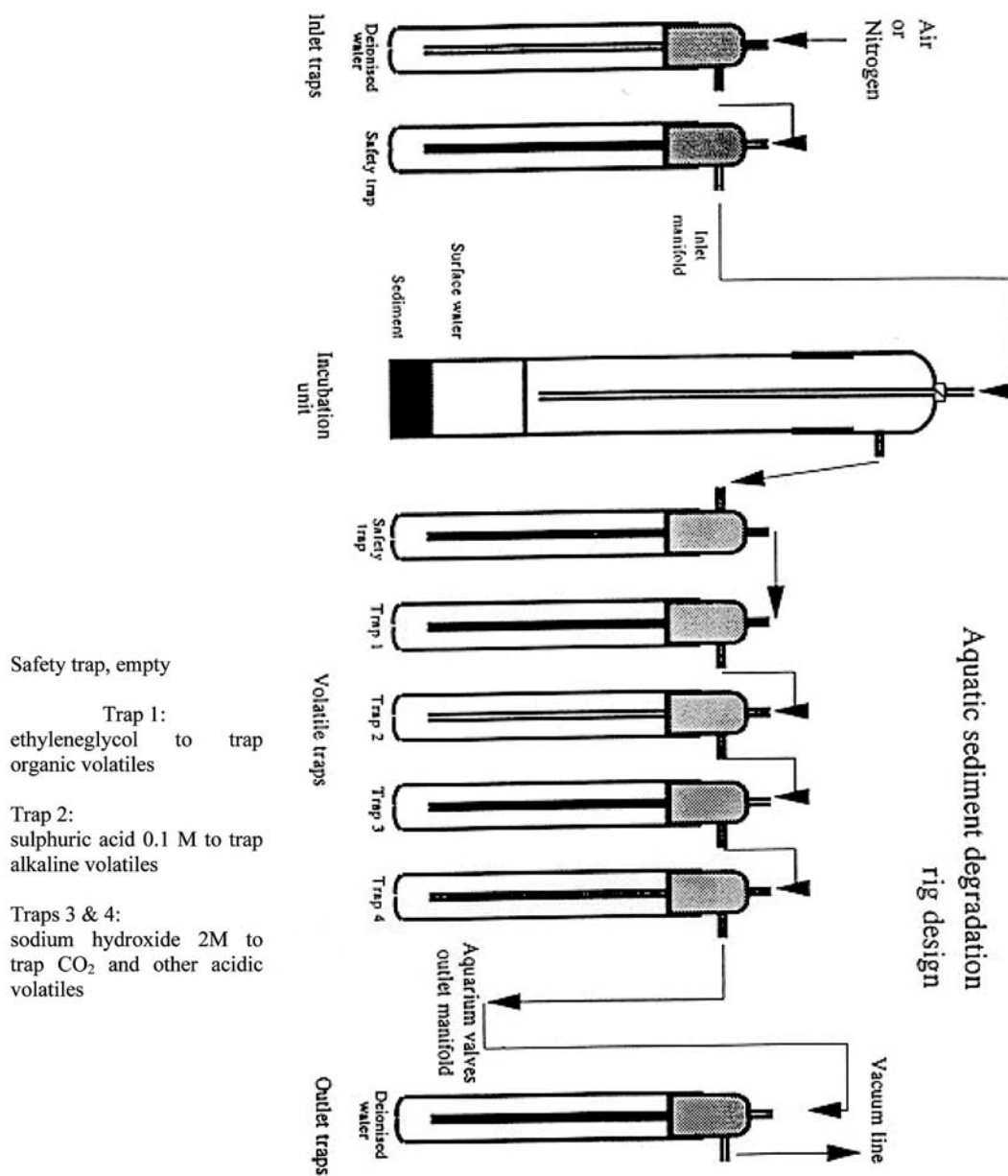

ANNEX 3

EXAMPLE OF A BIOMETER APPARATUS

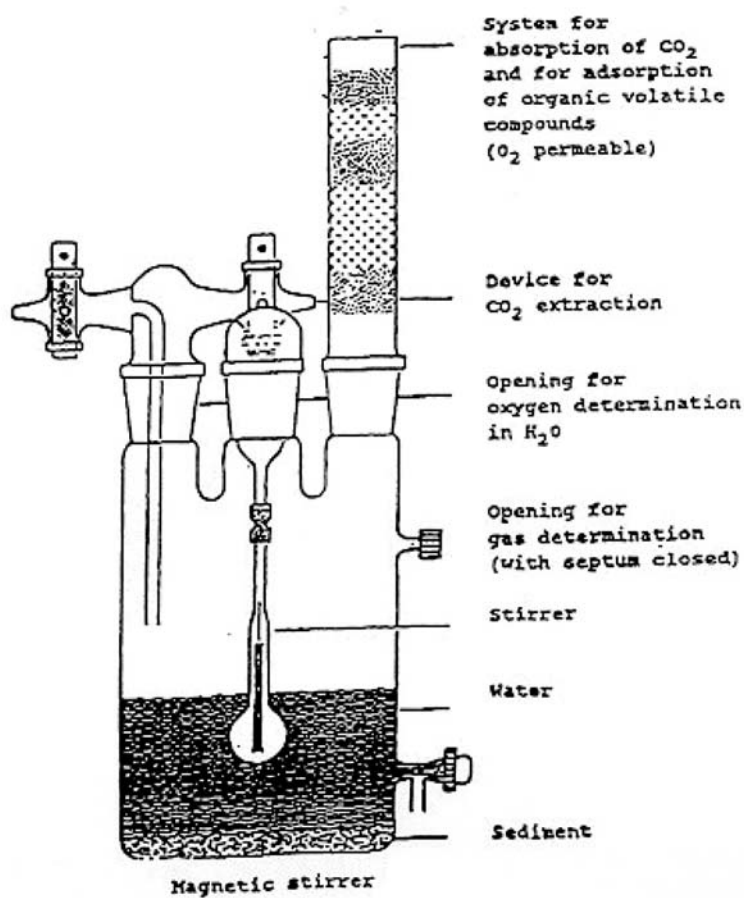

## ANNEX 4

## EXAMPLE CALCULATION FOR APPLICATION DOSE TO TEST VESSELS

|   |                            |
|---|----------------------------|
| Cylinder internal diameter:   | = 8 cm                     |
| Water column depth not including sediment:                                    | = 12 cm                    |
| Surface area: $3,142 \times 4^2$  | = 50,3 cm <sup>2</sup>     |
| Application rate: 500 g test substance/ha corresponds to 5 µg/cm <sup>2</sup> |                            |
| Total µg: $5 \times 50,3$   | = 251,5 µg                 |
| Adjust quantity in relation to a depth of 100 cm: $12 \times 251,5 \div 100$  | = 30,18 µg                 |
| Volume of water column: $50,3 \times 12$                                      | = 603 ml                   |
| Concentration in water: $30,18 \div 603$                                      | = 0,050 µg/ml or 50 µg/l ' |

---