

Official Journal

of the European Communities

ISSN 0378 - 6978

L 186

Volume 29

8 July 1986

English edition

Legislation

Contents

I *Acts whose publication is obligatory*

.....

II *Acts whose publication is not obligatory*

Council

86/295/EEC:

- ★ Council Directive of 26 May 1986 on the approximation of the laws of the Member States relating to roll-over protective structures (ROPS) for certain construction plant 1

86/296/EEC:

- ★ Council Directive of 26 May 1986 on the approximation of the laws of the Member States relating to falling-object protective structures (FOPS) for certain construction plant 10

86/297/EEC:

- ★ Council Directive of 26 May 1986 on the approximation of the laws of the Member States relating to the power take-offs of wheeled agricultural and forestry tractors and their protection 19

86/298/EEC:

- ★ Council Directive of 26 May 1986 on rear-mounted roll-over protection structures of narrow-track wheeled agricultural and forestry tractors 26

2

Acts whose titles are printed in light type are those relating to day-to-day management of agricultural matters, and are generally valid for a limited period.

The titles of all other Acts are printed in bold type and preceded by an asterisk.

II

(Acts whose publication is not obligatory)

COUNCIL

COUNCIL DIRECTIVE

of 26 May 1986

on the approximation of the laws of the Member States relating to roll-over protective structures (ROPS) for certain construction plant

(86/295/EEC)

THE COUNCIL OF THE EUROPEAN COMMUNITIES,

Having regard to the Treaty establishing the European Economic Community, and in particular Article 100 thereof,

Having regard to the proposal from the Commission ⁽¹⁾,

Having regard to the opinion of the European Parliament ⁽²⁾,

Having regard to the opinion of the Economic and Social Committee ⁽³⁾,

Whereas in some Member States the design, construction and testing of roll-over protective structures for certain categories of construction plant are the subject of national provisions requiring such construction plant to be fitted with the abovementioned protective structures; whereas this situation is likely to create barriers to intra-Community trade; whereas the purpose of these provisions is to protect the operator of the plant; whereas it is therefore necessary to approximate these provisions;

Whereas Council Directive 84/532/EEC of 17 September 1984 on the approximation of the laws of the Member States relating to common provisions for construction plant and equipment ⁽⁴⁾ has defined a series of joint procedures — in particular, EEC type-approval, EEC type-examination and EEC self-certification — for the placing on the market and bringing into service of such construction plant; whereas provision should be made for the EEC type-examination

procedure, coupled with an EEC inspection procedure, in respect of roll-over protective structures for certain construction plant;

Whereas this Directive is a separate Directive within the meaning of the second paragraph of Article 3 of Directive 84/532/EEC;

Whereas the laboratory tests, performance criteria and deflection-limiting volume are laid down by ISO international standards; whereas reference should therefore be made to these existing standards;

Whereas technical progress necessitates rapid adaptation of the technical requirements; whereas the procedure laid down in Article 24 of Directive 84/532/EEC should therefore be adopted for such adaptations of this Directive,

HAS ADOPTED THIS DIRECTIVE:

Article 1

This Directive applies to roll-over protective structures (ROPS) for the construction plant listed under 2.1 in ISO standard 3471, second edition of 15 September 1980, hereinafter referred to as ISO standard 3471/2.

Article 2

Member States shall take all necessary steps to ensure that the construction plant referred to in Article 1 cannot be placed on the market unless it is fitted with suitable roll-over protective structures which comply with this Directive and with the type of structure that has satisfied EEC type-examination in accordance with Directive 84/532/EEC. These structures shall hereinafter be referred to as EEC protective structures.

⁽¹⁾ OJ No C 104, 28. 4. 1980, p. 29.

⁽²⁾ OJ No C 197, 4. 8. 1980, p. 66.

⁽³⁾ OJ No C 205, 11. 8. 1980, p. 27.

⁽⁴⁾ OJ No L 300, 19. 11. 1984, p. 111.

Article 3

1. The approved bodies referred to in Article 9 of Directive 84/532/EEC shall not issue an EEC type-examination certificate unless the type of EEC protective structure complies with the provisions of Annex I to this Directive.

The EEC type-examination tests may be performed in the manufacturer's laboratory under the supervision of the approved body.

2. All applications for EEC type-examination in respect of an EEC protective structure shall be accompanied by an information document conforming to the model in Annex II to this Directive.

3. For each type of EEC protective structure that has undergone the tests and examinations provided for in Annex I to this Directive, the approved body shall draw up a test report conforming to the model in Annex III to this Directive and shall issue an EEC type-examination certificate conforming to the model in Annex V to this Directive, by way of derogation from Directive 84/532/EEC.

4. By way of derogation from section 4.2 of Annex I to Directive 84/532/EEC, only Member States and the Commission may obtain the test report, part A, referred to in Annex III to this Directive, and, where appropriate, the technical data in part B.

The approved body which has issued the EEC type-examination certificate shall forward the above document upon a duly substantiated request by a Member State or the Commission.

Article 4

1. Each EEC protective structure shall be accompanied by a certificate of conformity in accordance with Article 18 (1) of Directive 84/532/EEC.

2. The manufacturer of the EEC protective structure shall affix to each structure a legible, permanent and indelible EEC conformity mark, a model of which is contained in Annex IV, and shall attach to the structure a label in accordance with section 9 of ISO standard 3471/2.

Article 5

1. When it is proposed to commence production of protective structures for which an EEC type-examination certificate has been issued, the manufacturer or his authorized representative established in the Community shall:

- (a) inform the approved body which issued the EEC type-examination certificate of:
 - the place of manufacture, and/or the place of warehousing within the Community,
 - the date of commencement of production and/or import;
- (b) allow representatives of the approved body access for the purpose of checking to the said places of

manufacture or warehousing and provide all necessary information relevant to such checks;

- (c) make available, at the request of the approved body and within a reasonable period, a sample selected by that body for checking purposes.

2. The holder of the EEC mark shall arrange for production to be checked so as to verify on a continuous and adequate basis that the EEC protective structures manufactured conform to the type tested as regards the materials used and the quality of workmanship.

Article 6

1. Each approved body shall, if appropriate in accordance with instructions from the Member State which approved it, carry out spot checks to see whether the EEC protective structures being manufactured conform to the type for which it issued the EEC type-examination certificate.

These checks shall enable the approved body to ascertain whether the manufacturer is in fact carrying out the conformity check referred to in Article 5 (2).

The approved body may also request and itself select a sample for checking purposes. A second test in accordance with Annex I, involving destroying the EEC protective structure and possible the chassis, shall be performed only if there are reasonable grounds for assuming that the structure does not comply with the performance requirements for the approved type.

2. If the place of manufacture is situated in a Member State other than that of the approved body which granted the EEC type-examination certificate, that body may collaborate with the approved body in the Member State in which the abovementioned checks are to take place.

The same shall apply to warehouses.

3. Each approved body may on its own responsibility delegate the task of performing the checking tests and operations to one or more laboratories.

Article 7

1. If the checks referred to in Article 6 reveal that the EEC protective structures do not conform to the type for which the EEC type-examination certificate was granted, or that not all the requirements of this Directive have been fulfilled, the approved body shall take one of the following measures against the holder of the EEC mark:

- (a) a warning, with a request that the infringements noted shall cease within a given period;

- (b) a warning as referred to in (a), but accompanied by a larger number of checks;
- (c) temporary suspension of the EEC type-examination certificate;
- (d) withdrawal of the EEC type-examination certificate.

These measures may be taken only by the approved body which granted the EEC type-examination certificate.

2. The first two measures shall be taken where the disparities do not affect the basic design of the EEC protective structures or where the infringements are minor ones and in no way impair safety.

One of the last two measures shall be taken where the disparities or infringements noted are substantial and in all cases where they represent a safety hazard.

3. Temporary suspension or withdrawal of the EEC type-examination certificate shall be notified without delay to the other approved bodies and to the Member States.

Article 8

No Member State may, on grounds relating to the requirements laid down in this Directive, refuse, prohibit or restrict the marketing, placing in service or use of construction plant referred to in Article 1 fitted with an adequate EEC protective structure.

Article 9

1. Any amendments necessary to adapt the Annexes to this Directive to technical progress shall be adopted in accordance with the procedure laid down in Article 24 of Directive 84/532/EEC.

2. The procedure laid down in Article 21 of Directive 84/532/EEC shall not be applicable.

Article 10

The provisions of this Directive shall not affect the Member States' entitlement to lay down, with due observance of the Treaty, the requirements they deem necessary to ensure that workers are protected when using the equipment in question, provided that this does not mean that the equipment is modified in a way not specified in the Directive.

Article 11

1. Member States shall adopt and publish the laws, regulations and administrative provisions necessary in order to comply with this Directive within 36 months of its notification ⁽¹⁾ and shall forthwith inform the Commission thereof.

They shall bring these provisions into force 48 months after notification of this Directive.

2. Member States shall communicate to the Commission the texts of the provisions of national law which they adopt in the field governed by this Directive.

Article 12

This Directive is addressed to the Member States.

Done at Brussels, 26 May 1986.

For the Council
The President
 G. BRAKS

⁽¹⁾ This Directive was notified to the Member States on 30 May 1986.

ANNEX I

1. The EEC protective structure of an item of construction plant must, as regards the laboratory tests and performance requirements, comply with international standard ISO 3471 (second edition, 15 September 1980) on the basis of the deflection-limiting volume defined in international standard ISO 3164 (second edition, 1 November 1979) as amended by Amendment No 1 of 1 December 1980.
2. The provisions of the section 7.5.2.7 of ISO standard 3471 (second edition, 15 September 1980) are regarded as fulfilled where the rate of application of force F (e.g. if this relates to the forward movement speed of the cylinder which develops this load) does not exceed the following values:

Mass of construction plant (m) kg	Rate of load application mm/s
$m \leq 20\,000$	3
$m > 20\,000 \leq 40\,000$	2
$m > 40\,000$	1

3. The following standards are referred to in ISO standard 3471/2:
 - ISO standard 3164, second edition, 1 November 1979, as amended by amendment No 1 of 1 December 1980,
 - ISO standard 3449, third edition of 15 April 1984,
 - ISO standard 6165, 1978 edition,
 - ISO standard 898/1, 1978 edition,
 - ISO standard 898/2, 1980 edition.

ANNEX II

**MODEL INFORMATION DOCUMENT TO BE FURNISHED FOR THE PURPOSE OF EEC
TYPE-EXAMINATION OF A ROLL-OVER PROTECTIVE STRUCTURE (ROPS) FOR CONSTRUCTION
PLANT**

1. **Equipment concerned**
 - 1.1. Name and address of manufacturer:
 - 1.2. Name and address of manufacturer's authorized representative, if any:
 - 1.3. Model:
 - 1.4. Trade mark or name:
 - 1.5. Type designations:
 - 1.6. Mass of equipment: kg (maximum mass with roll-over protective structure, normal attachments and full tanks, but without driver, payload or any towed accessories)
 - 1.7. Attachment of roll-over protective structure to the equipment: detachable/not detachable ⁽¹⁾

2. **Roll-over protective structure (if not manufactured by the maker of the equipment)**
 - 2.1. Name and address of manufacturer:
 - 2.2. Name and address of manufacturer's authorized representative, if any:
 - 2.3. Trade mark or name:
 - 2.4. Type designation:

3. **Any other construction plant to which the roll-over protective structure can be fitted**
 - 3.1. Name and address of manufacturer:
 - 3.2. Name and address of manufacturer's authorized representative, if any:
 - 3.3. Model:
 - 3.4. Trade mark or name:
 - 3.5. Type designations:
 - 3.6. Mass of equipment: kg (maximum mass with roll-over protective structure, normal attachments and full tanks, but without driver, payload or any towed accessories)
 - 3.7. Attachment of roll-over protective structure to the equipment: detachable/not detachable ⁽¹⁾

⁽¹⁾ Delete where inapplicable.

ANNEX III

MODEL TEST REPORT CONCERNING A ROLL-OVER PROTECTIVE STRUCTURE (ROPS) FOR CONSTRUCTION PLANT

Test Report No:

Name and address of approved body:

.....

Name and address of laboratory which carried out the test:

.....

Name of person who carried out the test:

PART A

1. Description of the ROPS — chassis combination

1.1. Construction plant on the chassis of which the test was carried out

1.1.1. Name and address of manufacturer and, where appropriate, name and address of manufacturer's authorized representative:

.....

1.1.2. Model:

1.1.3. Trade mark or name, and type designation:

1.1.4. Serial number (where applicable):

1.1.5. Component number of chassis:

1.2. Roll-over protective structure

1.2.1. Name and address of manufacturer and, where appropriate, name and address of manufacturer's authorized representative:

.....

1.2.2. Trade mark or name, and type designation:

1.2.3. Serial number (where applicable):

1.2.4. Number of protective structure:

2. Information provided by manufacturer

2.1. Mass of construction plant: kg (maximum mass with roll-over protective structure, normal attachments and full tanks, but without driver, payload or any towed accessories).

2.2. Arrangement of the deflection-limiting volume DLV according to drawing No (accurate 1:10 scale drawing attached to test report. Side and front views of the roll-over protective structure and of the surrounding parts, with indication of seat and deflection-limiting volume DLV in the correct positions. Indication of main dimensions of roll-over protective structure.)

3. Calculation of minimum performance requirements

3.1. Force F N under lateral loading

3.2. Energy absorption U J under lateral loading

3.3. Value of M kg under vertical loading

4. **Confirmation**

4.1. The minimum performance requirements specified in ISO 3471, second edition, of 15 September 1980 were satisfied in this test, the maximum mass of the construction plant being kg.

4.2. Date of test:

PART B

1. **Measuring instruments**

1.1. Description of instruments used:

1.2. Accuracy of instruments used in conformity with ISO Standard 3471, second edition of 15 September 1980:

2. **Photographs** (one photograph of the test set-up taken from the front or rear and one taken from the side at which the load is applied)

2.1. Prior to application of lateral load

2.2. At or near maximum lateral load

2.3. Prior to application of vertical load

2.4. At or near maximum vertical load

3. **Test results**3.1. *Lateral loading*

3.1.1. Maximum force applied, after energy absorption was reached or exceeded, without penetration of the deflection-limiting volume DLV by any part of the roll-over protective structure (ROPS) or of the simulated ground plane: N

3.1.2. Energy absorbed without penetration of the deflection-limiting volume DLV by any part of the roll-over protective structure (ROPS) or of the simulated ground plane: J

3.2. *Vertical loading*

Maximum load sustained without penetration of the deflection-limiting volume DLV by any part of the roll-over protective structure (ROPS) or of the simulated ground plane: kg

3.3. *Material temperature*

3.3.1. During the test the temperature of the roll-over protective structure and of the chassis was °C or the steel parts of the roll-over protective structure attained in conformity with EURONORM 45-63 the Charpy V-notch impact strength values with J at -30 °C in the case of the × mm test piece.

3.3.2. Strength classifications of the bolts: and nuts: used.

3.4. *Force-deflection curve*

A force-deflection curve in accordance with ISO Standard 3471, second edition of 15 September 1980 is attached.

(Place), (Date)

.....
(Signature)

ANNEX IV

EEC MARK OF CONFORMITY

The EEC mark provided for in Article 4 (2) of this Directive is a stylized letter **E** in a hexagon which contains:

- in the upper part, the serial number of the separate Directive allocated according to the chronological order of adoption, the capital letter(s) identifying the State whose approved body issued the certificate (B for Belgium, D for Federal Republic of Germany, DK for Denmark, F for France, I for Italy, IRL for Ireland, L for Luxembourg, NL for the Netherlands, UK for the United Kingdom, EL for Greece, ES for Spain, P for Portugal) and the two final figures of the year of issue of the EEC type-examination certificate; the number of the separate Directive to which the EEC type-examination certificate refers will be allocated by the Council when this Directive is adopted,
- in the lower part, the number of the EEC type-examination certificate.

An example of this mark is shown below:

Example:



EEC type-examination certificate granted in 1979 by an approved body in the Federal Republic of Germany, pursuant to this Directive.

EEC type-examination certificate No

The diameter of the circle surrounding the mark must not be less than 20 mm.

The mark of conformity must be affixed at a point immediately adjacent to or on the identification plate.

Where a roll-over protective structure and a falling-object protective structure are combined (ROPS and FOPS), the two corresponding marks of conformity must appear immediately adjacent to each other.

ANNEX V

MODEL EEC TYPE-EXAMINATION CERTIFICATE FOR A ROLL-OVER PROTECTIVE STRUCTURE

Name of approved body:

Notification of type-examination in respect of the harmonized requirements:

.....

.....

Type-examination No:

1. Category, make and type or trade name:

2. Name and address of manufacturer:

.....

3. Name and address of certificate holder:

.....

4. Date of submission for type-examination:

5. In respect of the following harmonized requirement:

6. Test laboratory:

.....

7. Date and number of laboratory report:

8. Date of type-examination:

.....

9. The following documents, bearing the type-examination number shown above, are annexed to this certificate:

.....

.....

10. Type and number of the chassis on which the tests were carried out:

.....

11. Mass of the item of plant on which the tests were carried out:

.....

12. Any additional information:

.....

.....

.....

(Place), (Date)

.....
(Signature)

COUNCIL DIRECTIVE
of 26 May 1986
on the approximation of the laws of the Member States relating to falling-object protective structures (FOPS) for certain construction plant

(86/296/EEC)

THE COUNCIL OF THE EUROPEAN COMMUNITIES,

Having regard to the Treaty establishing the European Economic Community, and in particular Article 100 thereof,

Having regard to the proposal from the Commission ⁽¹⁾,

Having regard to the opinion of the European Parliament ⁽²⁾,

Having regard to the opinion of the Economic and Social Committee ⁽³⁾,

Whereas in some Member States the design, construction and testing of falling-object protective structures for certain categories of construction plant under certain conditions of use are the subject of national provisions requiring these protective structures to comply with special technical criteria and undergo specific tests; whereas this situation is likely to create barriers to intra-Community trade; whereas it is therefore necessary to approximate these provisions;

Whereas Council Directive 84/532/EEC of 17 September 1984 on the approximation of the laws of the Member States relating to common provisions for construction plant and equipment ⁽⁴⁾ has defined a series of joint procedures — in particular, EEC type-approval, EEC-type examination and EEC self-certification — for the placing on the market and bringing into service of such construction plant; whereas provision should be made for the EEC type-examination procedure, coupled with an EEC inspection procedure, in respect of falling-object protective structures for certain construction plant; whereas, moreover, it is necessary to make provision for this construction plant to be designed with attachment points, so that it can be fitted with the corresponding EEC protective structures;

Whereas this Directive is a separate Directive within the meaning of the second paragraph of Article 3 of Directive 84/532/EEC;

Whereas the laboratory tests, performance criteria and deflection-limiting volume are laid down by ISO international standards; whereas reference should therefore be made to these existing standards;

Whereas technical progress necessitates rapid adaptation of the technical requirements; whereas the procedure laid down in Article 24 of Directive 84/532/EEC should therefore be adopted for such adaptations of this Directive,

HAS ADOPTED THIS DIRECTIVE:

Article 1

This Directive applies to falling-object protective structures (FOPS) for the construction plant listed under 2.1 in ISO standard 3449, third edition of 15 April 1984, hereinafter referred to as ISO standard 3449/3.

Article 2

1. Member States shall take all necessary steps to ensure that:

- (a) falling-object protective structures cannot be placed on the market unless they comply with this Directive and the type of structure which has satisfied EEC type-examination in accordance with Directive 84/532/EEC.

These protective structures shall hereinafter be referred to as EEC protective structures;

- (b) the construction plant referred to in Article 1 cannot be placed on the market unless it is designed to be fitted with an EEC protective structure. Plant shall be considered to be designed to be fitted with an EEC protective structure if it is provided with a roll-over protective structure (ROPS) to which the aforesaid EEC protective structure can be fitted.

2. Member States may stipulate that, when used in certain normal conditions where the use of a falling-object protective structure is justified, the construction plant referred to in Article 1 may not be put into service or used unless fitted with an EEC protective structure.

Article 3

1. The approved bodies referred to in Article 9 of Directive 84/532/EEC shall not issue an EEC type-exami-

⁽¹⁾ OJ No C 104, 28. 4. 1984, p. 39.

⁽²⁾ OJ No C 197, 4. 8. 1980, p. 62.

⁽³⁾ OJ No C 205, 11. 8. 1980, p. 27.

⁽⁴⁾ OJ No L 300, 19. 11. 1984, p. 111.

nation certificate unless the type of EEC protective structure complies with the provisions of Annex I to this Directive.

The EEC type-examination tests may be performed in the manufacturer's laboratory under the supervision of the approved body.

2. All applications for EEC type-examination in respect of an EEC protective structure shall be accompanied by an information document conforming to the model in Annex II to this Directive.

3. For each type of EEC protective structure that has undergone the tests and examinations provided for in Annex I to this Directive, the approved body shall draw up a test report conforming to the model in Annex III to this Directive and shall issue an EEC type-examination certificate conforming to the model in Annex V to this Directive, by way of derogation from Directive 84/532/EEC.

4. By way of derogation from section 4.2 of Annex I to Directive 84/532/EEC, only Member States and the Commission may obtain the test report, part A, referred to in Annex III to this Directive, and, where appropriate, the technical data in part B.

The approved body which has issued the EEC type-examination certificate shall forward the above document upon a duly substantiated request by a Member State or the Commission.

Article 4

1. Each EEC protective structure shall be accompanied by a certificate of conformity in accordance with Article 18 (1) of Directive 84/532/EEC.

2. The manufacturer of the EEC protective structure shall affix to each structure a legible, permanent and indelible EEC conformity mark, a model of which is contained in Annex IV, and shall attach to the structure a label in accordance with section 8 of ISO standard 3449/3.

Article 5

1. When it is proposed to commence production of protective structures for which an EEC type-examination certificate has been issued, the manufacturer or his authorized representative established in the Community shall:

- (a) inform the approved body which issued the EEC type-examination certificate of:
 - the place of manufacture, and/or the place of warehousing within the Community,
 - the date of commencement of production and/or import;
- (b) allow representatives of the approved body access for the purpose of checking to the said places of manufacture or warehousing and provide all necessary information relevant to such checks;

- (c) make available, at the request of the approved body and within a reasonable period, a sample selected by that body for checking purposes.

2. The holder of the EEC mark shall arrange for production to be checked so as to verify on a continuous and adequate basis that the EEC protective structures manufactured conform to the type tested as regards the materials used and the quality of workmanship.

Article 6

1. Each approved body shall, if appropriate in accordance with instructions from the Member State which approved it, carry out spot checks to see whether the EEC protective structures being manufactured conform to the type for which it issued the EEC type-examination certificate.

These checks shall enable the approved body to ascertain whether the manufacturer is in fact carrying out the conformity check referred to in Article 5 (2).

The approved body may also request and itself select a sample for checking purposes. A second test in accordance with Annex I, involving destroying the EEC protective structure and possibly the chassis, shall be performed only if there are reasonable grounds for assuming that the structure does not comply with the performance requirements for the approved type.

2. If the place of manufacture is situated in a Member State other than that of the approved body which granted the EEC type-examination certificate, that body may collaborate with the approved body in the Member State in which the abovementioned checks are to take place.

The same shall apply to warehouses.

3. Each approved body may on its own responsibility delegate the task of performing the checking tests and operations to one or more laboratories.

Article 7

1. If the checks referred to in Article 6 reveal that EEC protective structures do not conform to the type for which the EEC type-examination certificate was granted, or that not all the requirements of this Directive have been fulfilled, the approved body shall take one of the following measures against the holder of the EEC mark:

- (a) a warning, with a request that the infringements noted shall cease within a given period;
- (b) a warning as referred to in (a), but accompanied by a larger number of checks;

- (c) temporary suspension of the EEC type-examination certificate;
- (d) withdrawal of the EEC type-examination certificate.

These measures may be taken only by the approved body which granted the EEC type-examination certificate.

2. The first two measures shall be taken where the disparities do not affect the basic design of the EEC protective structures or where the infringements are minor ones and in no way impair safety.

One of the last two measures shall be taken where the disparities or infringements noted are substantial and in all cases where they represent a safety hazard.

3. Temporary suspension or withdrawal of the EEC type-examination certificate shall be notified without delay to the other approved bodies and to the Member States.

Article 8

1. No Member State may, on grounds relating to the requirements laid down in this Directive, refuse, prohibit or restrict the marketing, placing into service or use of EEC protective structures.

2. No Member State may, on grounds relating to the requirements laid down in this Directive, refuse, prohibit or restrict the marketing, placing into service or use of construction plant as defined in Article 1 if it is fitted or designed to be fitted with an appropriate EEC protective structure.

Article 9

1. Any amendments necessary to adapt the Annexes to this Directive to technical progress shall be adopted in

accordance with the procedure laid down in Article 24 of Directive 84/532/EEC.

2. The procedure laid down in Article 21 of Directive 84/532/EEC shall not be applicable.

Article 10

The provisions of this Directive shall not affect the Member States' entitlement to lay down, with due observance of the Treaty, the requirements they deem necessary to ensure that workers are protected when using the equipment in question, provided that this does not mean that the equipment is modified in a way not specified in the Directive.

Article 11

1. Member States shall adopt and publish the laws, regulations and administrative provisions necessary in order to comply with this Directive within 36 months of its notification ⁽¹⁾ and shall forthwith inform the Commission thereof.

They shall bring these provisions into force 48 months after notification of this Directive.

2. Member States shall communicate to the Commission the texts of the provisions of national law which they adopt in the field governed by this Directive.

Article 12

This Directive is addressed to the Member States.

Done at Brussels, 26 May 1986.

For the Council,
The President
G. BRAKS

⁽¹⁾ This Directive was notified to the Member States on 2 June 1986.

ANNEX I

1. The EEC protective structure must, as regards the laboratory tests and performance requirements, comply with international standard ISO 3449, third edition, 15 April 1984, on the basis of the deflection-limiting volume defined in international standard ISO 3164, second edition, 1 November 1979, as amended by amendment No 1 of 1 December 1980.

2. The following standards are referred to in ISO standard 3449/3:

- ISO standard 3471, second edition, 15 September 1980,
- ISO standard 3164, second edition, 1 November 1979, as amended by amendment No 1 of 1 December 1980,
- ISO standard 6165, 1978 edition,
- ISO standard 898/1, 1978 edition,
- ISO standard 898/2, 1980 edition.

ANNEX II

MODEL INFORMATION DOCUMENT TO BE FURNISHED FOR THE PURPOSE OF EEC
TYPE-EXAMINATION OF A FALLING-OBJECT PROTECTIVE STRUCTURE (FOPS) FOR
CONSTRUCTION PLANT

- 1. **Equipment concerned**
 - 1.1. Name and address of manufacturer:
 - 1.2. Name and address of manufacturer's authorized representative, if any:
 - 1.3. Model:
 - 1.4. Trade mark or name:
 - 1.5. Type designation:
 - 1.6. Attachment of falling-object protective structure to the equipment: detachable/not detachable ⁽¹⁾

- 2. **Falling-object protective structure (if not manufactured by the maker of the equipment)**
 - 2.1. Name and address of manufacturer:
 - 2.2. Name and address of manufacturer's authorized representative, if any:
 - 2.3. Trade mark or name:
 - 2.4. Type designation:

- 3. **Any other construction plant to which the falling-object protective structure can be fitted**
 - 3.1. Name and address of manufacturer:
 - 3.2. Name and address of manufacturer's authorized representative, if any:
 - 3.3. Model:
 - 3.4. Trade mark or name:
 - 3.5. Type designation:
 - 3.6. Attachment of falling-object protective structure to the equipment: detachable/not detachable ⁽¹⁾

⁽¹⁾ Delete where inapplicable.

ANNEX III

MODEL TEST REPORT CONCERNING A FALLING-OBJECT PROTECTIVE STRUCTURE (FOPS) FOR CONSTRUCTION PLANT

Test Report No:

Name and address of approved body:

.....

Name and address of laboratory which carried out the test:

.....

Name of person who carried out the test:

PART A

1. Description of the FOPS — chassis combination

1.1. Construction plant on the chassis of which the test was carried out

1.1.1. Name and address of manufacturer and, where appropriate, name and address of manufacturer's authorized representative:

.....

1.1.2. Model:

1.1.3. Trade mark or name, and type designation:

1.1.4. Serial number (where applicable):

1.1.5. Component number of chassis:

1.2. Falling-object protective structure

1.2.1. Name and address of manufacturer and, where appropriate, name and address of manufacturer's authorized representative:

.....

1.2.2. Trade mark or name, and type designation:

1.2.3. Serial number (where applicable):

1.2.4. Number of protective structure:

2. Information provided by manufacturer

Arrangement of the deflection-limiting volume DLV according to drawing No (accurate 1:10 scale drawing attached to test report. Side and front views of the falling-object protective structure and of the surrounding parts, with indication of seat and deflection-limiting volume DLV in the correct positions. Indication of main dimensions of falling-object protective structure).

3. Confirmation

3.1. The minimum performance requirements specified in ISO standard 3449, third edition, 15 April 1984, were satisfied in this test.

3.2. Date of test:

PART B

- 1. Test-piece
 - 1.1. Shape of test-piece
 - 1.1.1. According to Figure 6 of ISO standard 3449, third edition, 15 April 1984
 - Diameter mm, length mm,
 - mass kg
 - 1.1.2. Sphere, diameter mm, mass kg
 - 1.2. Height of fall of test-piece mm
- 2. Photographs (photographs of the test up taken from the front or rear and from the side)
 - 2.1. Before loading
 - 2.2. After loading
- 3. Test results
 - 3.1. The falling-object protective structure absorbed: J of energy without penetration of the deflection-limiting volume (DLV) by any part of the falling-object protective structure
 - 3.2. Material temperature
 - 3.2.1. During the test the temperature of the falling-object protective structure and of the chassis was °C, or the metal parts of the falling-object protective structure attained in accordance with EURONORM 45-63, the Charpy V-notch impact strength values with J, at -30 °C in the case of the × mm test piece.
 - 3.2.2. Strength classification of the nuts and bolts used:
 - nuts:
 - bolts:

(Place), (Date)

.....
(Signature)

ANNEX IV

EEC MARK OF CONFORMITY

The EEC mark provided for in Article 4(2) of this Directive is a stylized letter **E** in a hexagon which contains:

- in the upper part, the serial number of the separate Directive allocated according to the chronological order of adoption, the capital letter(s) identifying the State whose approved body issued the certificate (B for Belgium, D for Federal Republic of Germany, DK for Denmark, F for France, I for Italy, IRL for Ireland, L for Luxembourg, NL for the Netherlands, UK for the United Kingdom, EL for Greece, ES for Spain, P for Portugal) and the two final figures of the year of issue of the EEC type-examination certificate; the number of the separate Directive to which the EEC type-examination certificate refers will be allocated by the Council when this Directive is adopted,
- in the lower part, the number of the EEC type-examination certificate.

An example of this mark is shown below:

Example:



EEC type-examination certificate granted in 1979 by an approved body in the Federal Republic of Germany, pursuant to this Directive.

EEC type-examination certificate No

The diameter of the circle surrounding the mark must not be less than 20 mm.

The mark of conformity must be affixed at a point immediately adjacent to or on the identification plate.

Where a roll-over protective structure and a falling-object protective structure are combined (ROPS and FOPS) the two corresponding marks of conformity must appear immediately adjacent to each other.

ANNEX V

MODEL EEC TYPE-EXAMINATION CERTIFICATE FOR A FALLING-OBJECT PROTECTIVE STRUCTURE

Name of approved body:

Notification of type-examination in respect of the harmonized requirement:

.....
.....
.....

Type-examination No:

1. Category, make and type or trade name:

2. Name and address of manufacturer:

3. Name and address of certificate holder:

4. Date of submission for type-examination:

5. In respect of the following harmonized requirement:

6. Test laboratory:

7. Date and number of laboratory report:

8. Date of type-examination:

9. The following documents, bearing the type-examination number shown above, are annexed to this certificate:

10. Type and number of the chassis on which the tests were carried out:

11. Any additional information:

(Place), (Date)

.....
(Signature)



COUNCIL DIRECTIVE

of 26 May 1986

on the approximation of the laws of the Member States relating to the power take-offs of wheeled agricultural and forestry tractors and their protection

(86/297/EEC)

THE COUNCIL OF THE EUROPEAN COMMUNITIES,

Having regard to the Treaty establishing the European Economic Community, and in particular Article 100 thereof,

Having regard to the proposal from the Commission ⁽¹⁾,

Having regard to the opinion of the European Parliament ⁽²⁾,

Having regard to the opinion of the Economic and Social Committee ⁽³⁾,

Whereas the technical requirements with which wheeled agricultural or forestry tractors must comply pursuant to national laws relate, *inter alia*, to the power take-off and its protection;

Whereas those requirements differ from one Member State to another; whereas it is therefore necessary that all Member States adopt the same requirements, either in addition to, or in place of, their existing rules, in particular in order to allow the EEC type-approval procedure which was the subject of Council Directive 74/150/EEC of 4 March 1974 on the approximation of the laws of the Member States relating to the type-approval of wheeled agricultural or forestry tractors ⁽⁴⁾, as last amended by the Act of Accession of Spain and Portugal, to be applied in respect of each tractor type;

Whereas the Council Resolution of 29 June 1978 concerning an action programme of the European Communities on safety and health at work ⁽⁵⁾ provides for the application of the principles of accident prevention in the design and creation of plant and machinery, including the agricultural sector; whereas the provisions concerning power take-offs and their protection constitute safety factors;

Whereas the approximation of the national laws relating to wheeled agricultural or forestry tractors entails reciprocal recognition by Member States of the checks carried out by each of them on the basis of common requirements,

HAS ADOPTED THIS DIRECTIVE:

Article 1

1. 'Agricultural or forestry tractors' means any motor vehicle, fitted with wheels or endless tracks, having at least

two axles, the main function of which lies in its tractive power and which is specially designed to tow, push, carry or power certain tools, machinery or trailers intended for agricultural or forestry use. It may be equipped to carry a load or passengers.

2. This Directive shall apply only to the tractors defined in paragraph 1, which are fitted with pneumatic tyres and have at least two axles and a maximum design speed of between 6 and 30 km/h.

Article 2

No Member State may refuse to grant EEC type-approval or national type-approval in respect of a tractor, or refuse or prohibit its sale, registration, entry into service or use, on grounds relating to the power take-off and its protection if the latter satisfy the requirements set out in Annex I.

Article 3

This Directive shall not affect the right of Member States to specify, with due observance of the Treaty, the requirements they deem necessary to ensure that workers are protected when using the tractors in question, provided this does not mean that the power take-off and its protection are modified in a way unspecified in this Directive.

Article 4

Any amendments necessary to adapt the requirements of Annex I and the model Annex to the EEC type-approval certificate shown in Annex II to technical progress shall be adopted in accordance with the procedure laid down in Article 13 of Directive 74/150/EEC.

Article 5

1. Member States shall bring into force the laws, regulations and administrative provisions necessary to comply with this Directive within 18 months of its adoption. They shall forthwith inform the Commission thereof. However, the requirements of section 5.2 of Annex I shall not apply until 1 October 1995.

⁽¹⁾ OJ No C 164, 23. 6. 1983, p. 5.

⁽²⁾ OJ No C 307, 14. 11. 1983, p. 104.

⁽³⁾ OJ No C 341, 19. 12. 1983, p. 2.

⁽⁴⁾ OJ No L 84, 28. 3. 1974, p. 10.

⁽⁵⁾ OJ No C 165, 11. 7. 1978, p. 3.

2. Member States shall ensure that the text of the main provisions of national law which they adopt in the field covered by this Directive are communicated to the Commission.

Done at Brussels, 26 May 1986.

Article 6

This Directive is addressed to the Member States.

For the Council
The President
G. BRAKS

ANNEX I

DEFINITION AND SCOPE, APPLICATION FOR EEC TYPE-APPROVAL, EEC, TYPE-APPROVAL, TYPES OF POWER TAKE-OFF AND DESIGN AND POSITIONING REQUIREMENTS IN RESPECT OF THE LATTER AND THEIR PROTECTIVE GUARDS

1. DEFINITION AND SCOPE

- 1.1. 'Power take-off' (PTO) means the projecting part of the tractor drive shaft which transmits motion to a machine.
- 1.2. The provisions of this Directive shall apply only to power take-offs as defined in 1.1 and located at the rear of the tractor. However, section 5.2 below shall apply only to tractors with a minimum fixed or adjustable track at one of the drive axles of at least 1 150 mm.

2. APPLICATION FOR EEC TYPE-APPROVAL

- 2.1. The application for the type approval of a tractor type as regards the power take-off and its protection must be submitted by the tractor manufacturer or his authorized representative.
- 2.2. It must be accompanied by drawings, in triplicate, on an appropriate and suitably detailed scale, of those parts of the tractor subject to the requirements of this Directive.
- 2.3. A tractor representative of the type submitted for approval or those part(s) of the tractor considered essential for the execution of the tests required by this Directive must be supplied to the technical service responsible for conducting the type-approval tests.

3. EEC TYPE-APPROVAL

- 3.1. A certificate conforming to the model which appears in Annex II must be attached to the EEC type-approval certificate for each approval granted or refused.

4. TYPES OF POWER TAKE-OFF

- 4.1. The characteristics of PTOs must conform to one of the types described in Table 1:

TABLE 1

Characteristics of types of PTO

Type	Nominal Diameter (mm)	Number of splines	Nominal PTO rotation speed rpm ⁽¹⁾
1	35	6 straight splines	} 540 and/or 1 000
2	35	21 } Involute serrations	
3	45	20 }	

⁽¹⁾ Except PTO whose rotation speed is linked to the tractor's ground speed.

- 4.2. It must be possible to maintain the rotation speed of the PTO by suitable means.
- 4.3. Should more than one ratio between the engine speed and the PTO rotation speed be provided, any change of ratio must be perceptible. In addition, specific design measures must be taken to ensure that unintentional changes of ratio — in particular changing to a higher rotation speed — cannot occur. This safety device must operate each time the PTO is engaged.
- 4.4. Means must be provided by which the selected PTO rotation speed is clearly indicated at all times.

5. DESIGN AND POSITIONING REQUIREMENTS

5.1. Direction of rotation of the rear PTO

Clockwise when the PTO is observed in the direction of travel of the tractor.

5.2. Zone of clearance around the PTO

The PTO zone of clearance must be in conformity with the drawings in Figure 1 and the dimensions in Table 2.

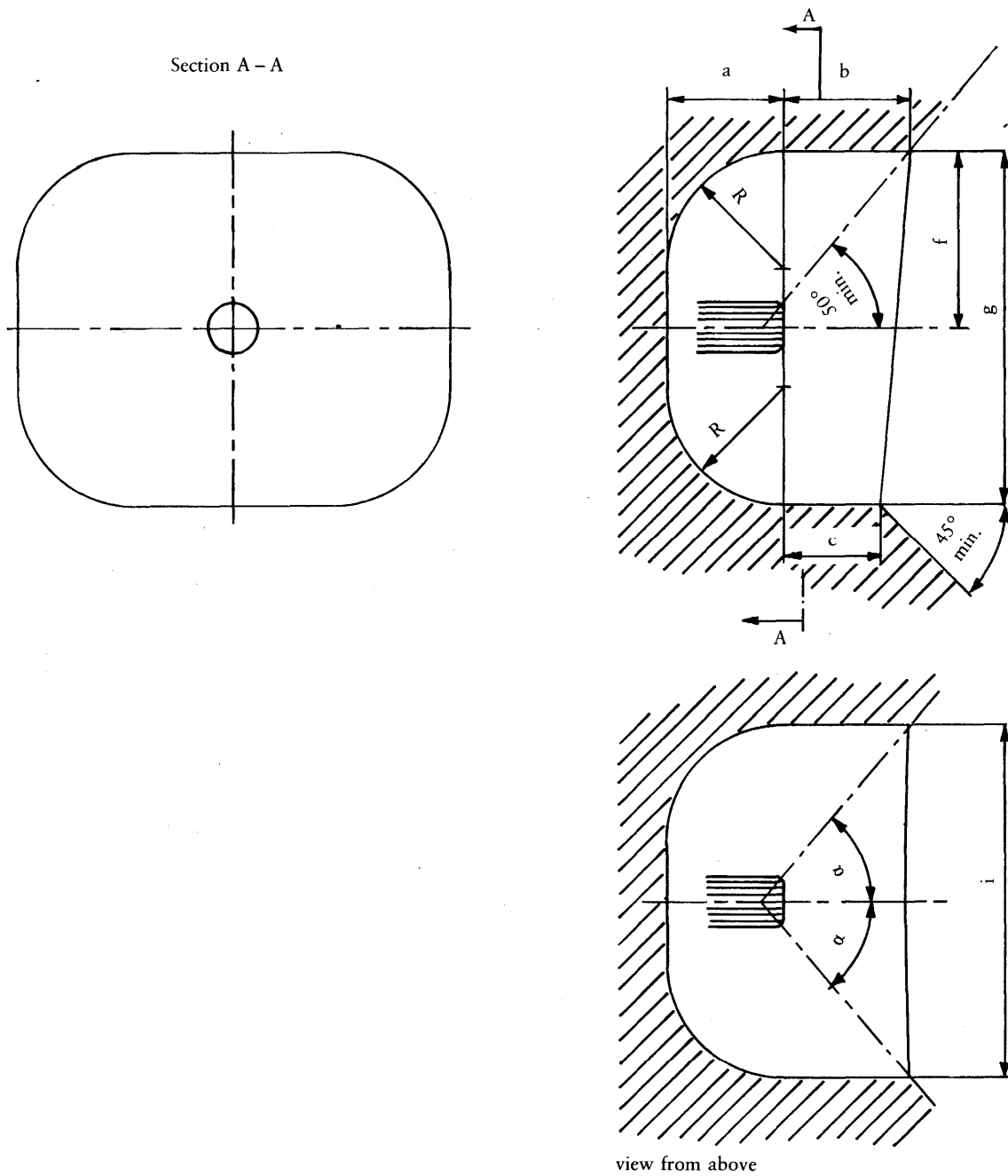

Figure 1

Zone of clearance around PTO

TABLE 2

Dimensions of the clearance zone

Type	a min.	b max.	c max.	f min.	g min.	i min.	R spheric max.	α min.
1	76	80	60	120	240	280	76	55°
2								
3	89	100	65	145	290	295	89	51°

5.3. Protection of PTOs

5.3.1. Protection

- 5.3.1.1. The power take-off must be protected by a guard mounted on the tractor which covers at least the top part and the two sides of the PTO as shown in Figure 2 below, or by other means providing a similar degree of protection such as the location of the PTO in a recess that is part of the tractor or is formed by a separate part (tow-hook mounts, coupling cover, etc.).
- 5.3.1.2. The dimensions of the protective guard are laid down, as a function of the type of PTO, in Table 3 below.
- 5.3.1.3. An additional non-rotating protective device which fully covers the PTO must also be supplied with the tractor to protect the PTO when the latter is not in use.

5.3.2. Characteristics of protective guards

- 5.3.2.1. The protective guard must be designed so as not to impede (or in order to facilitate) the use and maintenance of the tractor.
It must be possible to carry out maintenance operations without removing the protective guard.
- 5.3.2.2. The materials used must be able to withstand bad weather, must retain their mechanical properties in cold weather and must be sufficiently sturdy.
- 5.3.2.3. The protective guard must have no points or sharp edges; it must contain no orifices exceeding 8 mm diameter or side of a square or rectangle other than that necessary for attaching the chain of the protective device for the universal-joint drive shaft and must be able to bear a weight of 120 daN, unless it is designed in such a way that it cannot be used as a step.

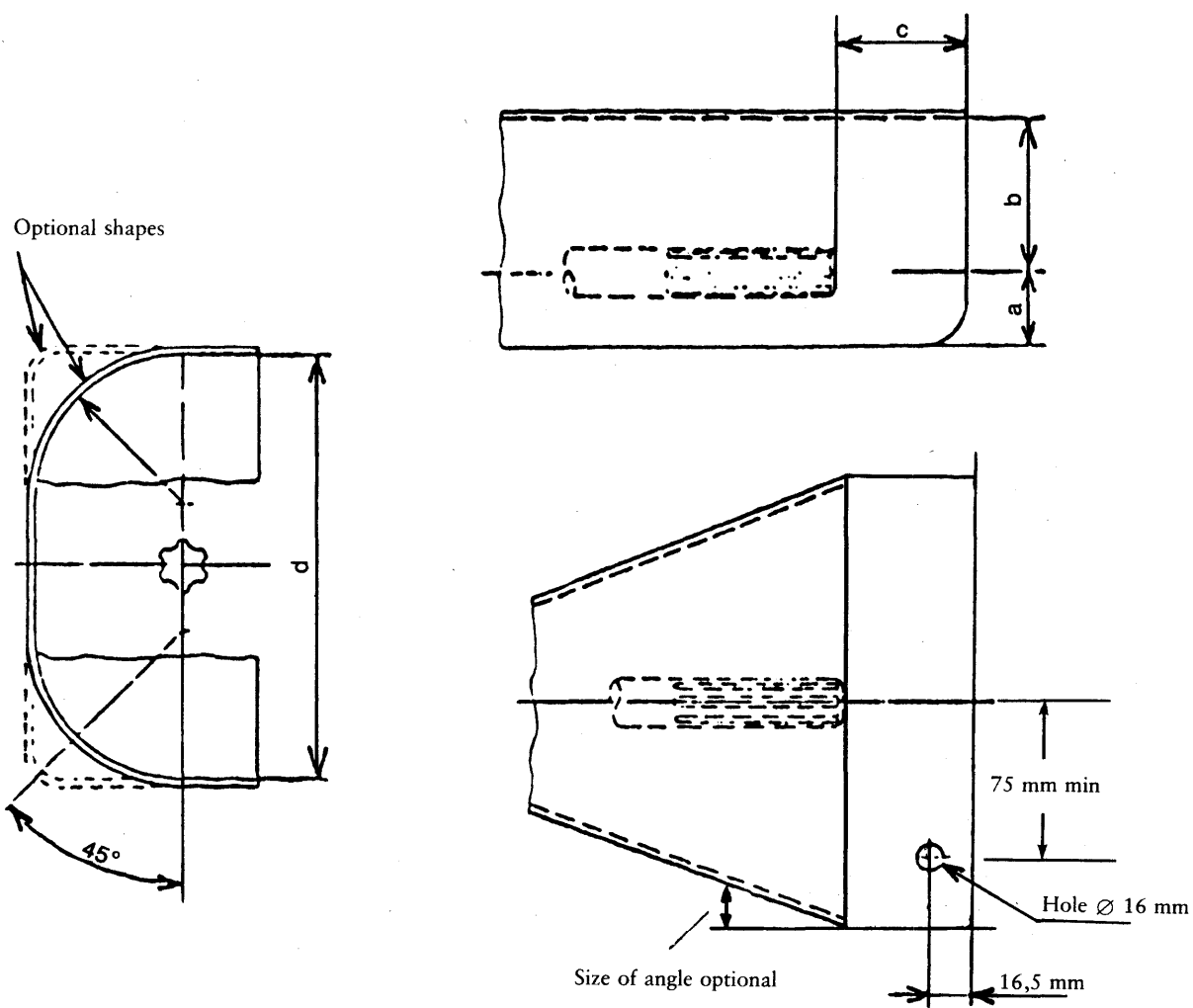

Figure 2

Protective guard for type 1, 2 and 3 PTOs

TABLE 3

Dimensions of the power take-off protective guard

Type	Dimensions of protective guard ⁽¹⁾ (mm)			
	a	b ± 5	c ± 5	d ± 5
1	70	125	85	285
2	70	125	85	285
3	80	150	100	300

⁽¹⁾ In the case of tractors having two rear PTO shafts, the dimensions b and/or d may be adjusted in order to maintain equivalent clearance areas between the shafts and the protective guard.

ANNEX II

MODEL

Name of administration

ANNEX TO THE EEC TYPE-APPROVED CERTIFICATE FOR A TRACTOR TYPE WITH REGARD TO THE POWER TAKE-OFF AND ITS PROTECTION

(Articles 4 (2) and 10 of Council Directive 74/150/EEC of March 1974 on the approximation of the laws of the Member States relating to the type approval of wheeled agricultural or forestry tractors)

EEC type-approval No:

1. Trade name or mark of tractor:
2. Tractor type:
3. Name and address of manufacturer:
4. If applicable, name and address of manufacturer's authorized representative:
5. Brief description of type of power take-off and its protection:
6. Date tractor submitted for type-approval:
7. Technical service responsible for type-approval tests:
8. Date of report by that service:
9. Number of report issued by that service:
10. EEC type-approval with regard to the power take-off and its protection has been granted/refused ⁽¹⁾.
11. The following drawings bearing the abovementioned type-approval No are attached to this communication:
 A set of drawings of those parts of the tractor considered of interest for the purposes of Council Directive 86/297/EEC of 26 May 1986 on the approximation of the laws of the Member States relating to power take-offs of wheeled agricultural on forestry tractors and their protection.
 These drawings will be supplied to the competent authorities of the Member States at their express request.
12. Remarks, if any:
13. Place:
14. Date:
15. Signature:

⁽¹⁾ Delete where inapplicable.

COUNCIL DIRECTIVE

of 26 May 1986

on rear-mounted roll-over protection structures of narrow-track wheeled agricultural and forestry tractors

(86/298/EEC)

THE COUNCIL OF THE EUROPEAN COMMUNITIES,

Having regard to the Treaty establishing the European Economic Community, and in particular Article 100 thereof,

Having regard to the proposal from the Commission ⁽¹⁾,

Having regard to the opinion of the European Parliament ⁽²⁾,

Having regard to the opinion of the Economic and Social Committee ⁽³⁾,

Whereas Council Directive 74/150/EEC of 4 March 1974 on the approximation of the laws of the Member States relating to the type-approval of wheeled agricultural or forestry tractors ⁽⁴⁾, as last amended by the Act of Accession of Spain and Portugal, lays down that the necessary provisions for the implementation of the EEC type-approval procedure in respect of individual tractor parts or characteristics should be specified in special directives; whereas the provisions relating to roll-over protection structures and their attachments to tractors were laid down by Directives 77/536/EEC ⁽⁵⁾ and 79/622/EEC ⁽⁶⁾, as last amended by the Act of Accession of Spain and Portugal; whereas these two Directives cover respectively dynamic and static testing procedures — either of which may be employed by manufacturers for the present — and relate to standard tractors, that is, tractors having a maximum ground clearance of 1 000 mm and a fixed or adjustable track width of one of the driving axles of not less than 1 150 mm and weighing between 1,5 and 4,5 tonnes in the case of tractors covered by the 'dynamic testing' Directive and not less than 800 kilograms in the case of tractors covered by the 'static testing' Directive;

Whereas the tractors covered by this Directive have a maximum ground clearance of 600 mm, a minimum track width of both axles of less than 1 150 mm and a mass greater than 600 kilograms; whereas the roll-over protection structures of these tractors, which are used for specific activities, can be made subject to specific requirement or requirements other than those of Directive 77/536/EEC and 79/622/EEC;

Whereas the technical requirements with which such 'narrow-track' tractors must comply pursuant to national laws relate *inter alia* to roll-over protection structures and to their attachment to the tractor; whereas those requirements differ from one Member State to another; whereas it is therefore necessary that all Member States adopt the same requirements either in addition to or in place of their existing rules in order, in particular, to allow the EEC type-approval procedure which was the subject of Directive 74/150/EEC to be introduced in respect of each type of tractor;

Whereas this Directive covers roll-over protection structures of the rear-mounted rollbar, frame or cab type having a zone of clearance whose upper limit is 900 mm above the seat reference point in order to provide a sufficiently large area or unobstructed space for the protection of the driver; whereas another special Directive will be adopted in respect of roll-over protection structures having two pillars mounted in front of the driver;

Whereas a harmonized component type-approval procedure for roll-over protection structures and their attachment to the tractor makes it possible for each Member State to check compliance with the common construction and testing requirements and to inform the other Member States of its findings by sending them copies of the component type-approval certificate completed for each type of roll-over protection structure and its attachment to the tractor; whereas the placing of an EEC component type-approval mark on all structures manufactured in conformity with the approved type obviates any need for technical checks on those structures in the other Member States; whereas common requirements concerning other elements and characteristics of the roll-over protection structure, in particular, devices to prevent continuous roll-over if the tractor overturns, and protection of occupants, will be laid down at a later date;

Whereas the harmonized requirements are intended principally to ensure safety on the road and at work throughout the Community; whereas, for this reason, it is necessary to introduce the obligation for tractors covered by this Directive to be fitted with roll-over protection structures;

Whereas the approximation of the national laws relating to these tractors entails reciprocal recognition by Member States of the checks carried out by each of them on the basis of the common requirements,

⁽¹⁾ OJ No C 123, 9. 5. 1983, p. 1.

⁽²⁾ OJ No C 307, 14. 11. 1983, p. 103.

⁽³⁾ OJ No C 286, 24. 10. 1983, p. 2.

⁽⁴⁾ OJ No L 84, 28. 3. 1974, p. 10.

⁽⁵⁾ OJ No L 220, 29. 8. 1977, p. 1.

⁽⁶⁾ OJ No L 179, 17. 7. 1979, p. 1.

HAS ADOPTED THIS DIRECTIVE:

Article 1

This Directive shall apply to tractors as defined in Article 1 of Directive 74/150/EEC having the following characteristics:

- ground clearance of not more than 600 mm measured beneath the lowest points of the front or rear axles, allowing for the differential,
- fixed or adjustable minimum track width of one of the two axles less than 1 150 mm; under no circumstances must the outer edge of the tyres on the other axle go beyond the outer edge of the tyres on the axle of 1 150 mm minimum track width,
- mass greater than 600 kilograms and corresponding to the unladen weight of the tractor as defined in section 2.4 of Annex I to Directive 74/150/EEC, including the roll-over protection structure fitted in compliance with this Directive and tyres of the largest size recommended by the manufacturer.

Article 2

1. Each Member State shall grant EEC component type-approval for any type of roll-over protection structure and its tractor attachment which satisfies the construction and testing requirements laid down in Annexes I to IV.

2. A Member State which has granted EEC component type-approval shall take the measures required to verify, in so far as is necessary and if need be in cooperation with the competent authorities in the other Member States, that production models conform to the approved type. Such verification shall be limited to spot checks.

Article 3

Member States shall, for each type of roll-over protection structure and its tractor attachment which they approve pursuant to Article 2, issue to the manufacturer of the tractor or of the roll-over protection structure, or to his authorized representative, an EEC component type-approval mark conforming to the model shown in Annex VI.

Member States shall take all appropriate measures to prevent the use of marks liable to create confusion between roll-over protection structures which have been component type-approved pursuant to Article 2 and other devices.

Article 4

1. No Member State may prohibit the placing on the market of roll-over protection structures or their attachment

to the tractors for which they are intended on grounds relating to their construction if they bear the EEC component type-approval mark.

2. Nevertheless, a Member State may prohibit the placing on the market of roll-over protection structures bearing the EEC component type-approval mark which consistently fail to conform to the approved type.

That State shall forthwith inform the other Member States and the Commission of the measures taken, specifying the reasons for its decision.

Article 5

The competent authorities of each Member State shall, within one month, send to the competent authorities of the Member State a copy of the component type-approval certificates, an example of which is given in Annex VII, completed for each type of roll-over protection structure which they approve or refuse to approve.

Article 6

1. If the Member State which has granted EEC component type-approval finds that a number of roll-over protection structures and their tractor attachments bearing the same EEC component type-approval mark do not conform to the type which it has approved, it shall take the necessary measures to ensure that production models conform to the approved type. The competent authorities of that State shall advise those of the other Member States of the measures taken which may, if necessary, where there is serious and repeated failure to conform, extend to withdrawal of EEC component type-approval. The said authorities shall take the same measures if they are informed by the competent authorities of another Member State of such failure to conform.

2. The competent authorities of the Member States shall within one month inform each other of any withdrawal of EEC component type-approval and of the reasons for any such measure.

Article 7

Any decision taken pursuant to the provisions adopted in implementation of this Directive to refuse or withdraw component type-approval for roll-over protection structures and their tractor attachments, or to prohibit their placing on the market or their use, shall set out in detail the reasons on which it is based. Such decisions shall be notified to the party concerned, who shall at the same time be informed of the remedies available to him under the laws in force in the Member States and of the time limits allowed for the exercise of such remedies.

Article 8

No Member State may refuse to grant EEC type-approval or national type-approval in respect of a tractor on grounds

relating to roll-over protection structures or their tractor attachment if these bear the EEC component type-approval mark and if the requirements laid down in Annex VIII have been satisfied.

Article 9

No Member State may refuse or prohibit the sale, registration, entry into service or use of any tractor on grounds relating to the roll-over protection structure and its tractor attachment if these bear the EEC component type-approval mark and if the requirements laid down in Annex VIII have been met.

Article 10

This Directive shall not affect the right of Member States to specify — in due compliance with the Treaty — the requirements they deem necessary to ensure that workers are protected when using the tractors in question, provided this does not mean that the protection structures are modified in a way unspecified in this Directive.

Article 11

1. In connection with EEC type-approval, any tractor to which Article 1 refers must be fitted with a roll-over protection structure.
2. Where the protection structure is not one having two pillars mounted in front of the driver's seat, the structure referred to in paragraph 1 must comply with the requirements laid down in Annexes I to IV to this Directive or to Directives 77/536/EEC or 79/622/EEC.

Article 12

Any amendments necessary in order to adapt the requirements of the Annexes to this Directive so as to take account of technical progress shall be adopted in accordance with the procedure laid down in Article 13 of Directive 74/150/EEC.

Article 13

Within 18 months of the notification of this Directive, the Council, acting on a proposal from the Commission, on the basis of the provisions of the Treaty, shall adopt a Directive supplementing this Directive by means of provisions introducing the additional impact tests in the dynamic test procedure.

Article 14

1. Member States shall bring into force the provisions necessary in order to comply with this Directive within 24 months of its notification ⁽¹⁾. They shall forthwith inform the Commission thereof.
2. Member States shall ensure that the texts of the main provisions of national law which they adopt in the field covered by this Directive are communicated to the Commission.

Article 15

This Directive is addressed to the Member States.

Done at Brussels, 26 May 1986.

For the Council
The President
G. BRAKS

⁽¹⁾ This Directive was notified to the Member States on 2 June 1986.

LIST OF ANNEXES

ANNEX I	Conditions for EEC component type-approval
ANNEX II	Conditions for testing the strength of the protection structures and of their attachment to tractors
ANNEX III	Test procedures A. Dynamic testing B. Static testing
ANNEX IV	Figures
ANNEX V	Model report relating to the EEC component type-approval tests of a protection structure with regard to its strength as well as to the strength of its attachment to the tractor
ANNEX VI	Marks
ANNEX VII	Model EEC component type-approval certificate.
ANNEX VIII	Conditions for EEC type-approval
ANNEX IX	Annex to the EEC type-approval certificate for a tractor type with regard to the strength of the protection structures and the strength of their attachment to the tractor

ANNEX I

CONDITIONS FOR EEC COMPONENT TYPE-APPROVAL

1. DEFINITION
 - 1.1. 'Roll-over protection structure for the driver', hereinafter called 'protection structure', means the structure on a tractor the essential purpose of which is to avoid or limit risks to the driver resulting from roll-over of the tractor during normal use.
 - 1.2. The structures mentioned in Item 1.1 are characterized by the fact that, during the tests prescribed in Annexes II and III, they ensure sufficient unobstructed space to protect the driver.
2. GENERAL REQUIREMENTS
 - 2.1. Every protection structure and its attachment to a tractor must be so designed and constructed as to fulfil the essential purpose laid down in Item 1.1 above.
 - 2.2. This condition is considered to be fulfilled when the requirements of Annexes II and III are complied with.
3. APPLICATION FOR EEC COMPONENT TYPE-APPROVAL
 - 3.1. The application for EEC component type-approval with regard to the strength of a protection structure and the strength of its attachment to a tractor shall be submitted by the tractor manufacturer or by the manufacturer of the protection structure or by their authorized representatives.
 - 3.2. The application for EEC component type-approval shall be accompanied by the undermentioned documents in triplicate and by the following particulars:
 - general arrangement drawing either to a scale marked on the drawing or giving the main dimensions of the protection structure. This drawing must, in particular, show details of the mounting components,
 - photographs from side and rear showing mounting details,
 - brief description of the protection structure including type of construction, details of mounting on the tractor and, where necessary, details of cladding, means of access and escape, details of interior padding and features to prevent continuous rolling and details of heating and ventilation,
 - details of materials used in structural parts including attaching brackets and fixing bolts (see Annex V).
 - 3.3. A tractor representative of the tractor type for which the protection structure to be approved is intended shall be submitted to the technical service responsible for conducting the component type-approval tests. This tractor shall be fitted with the protection structure.
 - 3.4. The holder of EEC component type-approval may request its extension to other tractor types. The competent authority which has granted the original EEC component type-approval shall grant the extension if the approved protection structure and the type(s) of tractor for which the extension is requested comply with the following conditions:
 - the mass of the unballasted tractor, as defined in Item 1.4 of Annex II, does not exceed by more than 5 % the reference mass used in the tests,
 - the wheelbase or the moment of inertia in relation to the rear-wheel axle is not more than the reference wheelbase or moment of inertia,
 - the method of attachment and the points of attachment to the tractor are identical,
 - any components, such as mudguards and bonnet which may provide support for the protection structure have identical strength and are identically situated with respect to the protection structure,
 - the critical dimensions and the position of the seat and steering wheel relative to the protection structure, and the position relative to the protection structure of the points deemed rigid and taken

into account for the purpose of verifying that the zone of clearance is protected, are such that the zone of clearance continues to be protected by the structure after the latter has undergone the deformation resulting from the various tests.

4. MARKINGS

4.1. Every protection structure conforming to the approved type shall bear the following markings:

4.1.1. The trade mark or name.

4.1.2. A component type-approval mark conforming to the model in Annex VI.

4.1.3. Serial number of the protection structure.

4.1.4. Make and type(s) of tractor(s) for which the protection structure is intended.

4.2. All these particulars must appear on a small plate.

4.3. These markings must be visible, legible and indelible.

ANNEX II

CONDITIONS FOR TESTING THE STRENGTH OF PROTECTION STRUCTURES AND THEIR ATTACHMENT TO TRACTORS

1. GENERAL REQUIREMENTS

1.1. Test purposes

Tests made using special rigs are intended to simulate such loads as are imposed on a protection structure, when the tractor overturns. These tests, described in Annex III, enable observations to be made on the strength of the protection structure and any brackets attaching it to the tractor and any parts of the tractor which transmit the test force.

1.2. Test methods

Tests may be performed in accordance with the dynamic procedure (see Annexes II A and III A) or the static procedure (see Annexes II B and III B) at the manufacturer's choice.

The two methods are equivalent.

1.3. General rules governing preparation for tests

1.3.1. The protection structure must conform to the series production specifications. It shall be attached in accordance with the manufacturer's recommended method to one of the tractors for which it is designed.

A complete tractor is not required for the strength test in static testing; however, the protection structure and parts of the tractor to which it is attached shall represent an operating installation, hereinafter referred to as 'the assembly'.

1.3.2. For the strength test the tractor must be fitted with all series production components which may affect the strength of the protection structure or which may be necessary for the strength test.

Components which may create a hazard in the zone of clearance must also be fitted so that they may be examined to see whether the requirements of Items 3.1 and 3.2 have been fulfilled.

All components of the tractor or the protection structure including weather protection must be supplied or defined in drawings.

1.3.3. For the strength tests, all detachable windows, doors, panels and non-structural fittings must be removed so that they may not contribute to the strengthening of the protection structure.

1.3.4. Track width

The track width shall be adjusted such that the protection structure will, as far as possible, not be supported by the tyres during the strength tests. If these tests are conducted in accordance with the static procedure, the wheels may be removed.

1.4. Tractor reference mass

The reference mass ' m_t ', used in the formulae (see Annex III A and III B) to calculate the height of fall of the pendulum block, the loading energies and the crushing forces, shall be at least that defined in Item 2.4 of Annex I to Council Directive 74/150/EEC (i.e. excluding 'optional' accessories but including coolant, oils, fuel, tools and driver) plus the protection structure and less 75 kilograms. Not included are 'optional' front or rear weights, tyre ballast, mounted implements, mounted equipment or any specialized component.

2. TESTS

2.1. Sequence of tests

The sequence of tests, without prejudice to the additional dynamic and static tests (Annex III A and Annex III B), is as follows:

2.1.1. Impact (dynamic tests) or loading (static tests) at the rear of the structure (see Item 1.1 of Annexes III A and III B)

2.1.2. Rear crushing (dynamic or static tests) (see Item 1.4 of Annexes III A and III B)

2.1.3. Impact (dynamic tests) or loading (static tests) at the front of the structure (see Item 1.2 of Annexes III A and III B)

- 2.1.4. Impact (dynamic tests) or loading (static tests) to the side of the structure (see Item 1.3 of Annexes III A and III B)
- 2.1.5. Crushing at the front of the structure (dynamic or static tests) (see Item 1.5 of Annexes III A and III B)
- 2.2. **General requirements**
- 2.2.1. If, during the test, any part of the restraining equipment breaks or moves, the test shall be restarted.
- 2.2.2. No repairs or adjustments to the tractor or to the protection structure may be carried out during the tests.
- 2.2.3. The tractor gear-box shall be in neutral and the brakes off during the tests.
- 2.2.4. If the tractor is fitted with a suspension system between the tractor body and the wheels, it shall be blocked during the tests.
- 2.2.5. The side chosen for application of the first impact on the rear of the structure (in the case of dynamic tests) or the first load on the rear of the structure (in the case of static tests) shall be that which, in the opinion of the testing authorities will result in the application of the series of impacts or loads under the most unfavourable conditions for the structure. The lateral impact or load and the rear impact or load shall be on different sides of the longitudinal median plane of the protection structure. The front impact or load shall be on the same side of the longitudinal median plane of the protection structure as the lateral impact or load.
- 2.3. **Measurement tolerances**
- 2.3.1. Linear dimensions: ± 3 mm.
Except for: — tyre deflection: ± 1 mm,
— structure deflection during horizontal loading: ± 1 mm,
— each of the two measurements for the height of fall of the pendulum block: ± 1 mm.
- 2.3.2. Masses: ± 1 %.
- 2.3.3. Forces: ± 2 %.
- 2.3.4. Angles: $\pm 2^\circ$.
3. **ACCEPTANCE CONDITIONS**
- 3.1. A protection structure submitted for EEC component type-approval shall be considered as having satisfied the strength requirements if it fulfils the following conditions:
- 3.1.1. After each part-test in the dynamic test, it shall be free from cracks or tears as described in Item 3.1 of Annex III A.
If, during a dynamic crushing test, unacceptable cracks or tears appear, an additional crushing test, as defined in Item 1.6 of Annex III A must be applied immediately after the crushing test which caused the cracks or tears to appear.
- 3.1.2. During static testing, at the point when the energy required is attained in each horizontal load test prescribed or in the overload test (see Figures 10a, 10b and 10c of Annex IV) the force must be greater than $0,8 F_{\max}$.
- 3.1.3. If, during a static test, cracks or tears appear as a result of the application of the crushing force, an additional crushing test, as defined in Item 1.7 of Annex III B, may be carried out immediately after the crushing test which caused the cracks or tears to appear.
- 3.1.4. Additional cracks or tears and/or entry into or lack of protection of the zone of clearance are permitted during the overload test.
- 3.1.5. During the tests, other than the overload test, no part of the protection structure shall enter the zone of clearance as defined in Item 2 of Annexes III A and III B.
- 3.1.6. During the tests, other than the overload test, no part of the zone of clearance shall be outside the protection of the structure, in accordance with Item 3.2.2 of Annexes III A and III B.
- 3.1.7. During the tests the protection structure must not impose any constraints on the seat structure.

- 3.1.8. The elastic deflection, measured in accordance with Item 3.3 of Annexes III A and III B, shall be less than 250 mm.
- 3.2. There shall be no accessories presenting a hazard for the driver. There shall be no projecting part or accessory which is liable to injure the driver should the tractor overturn, or any part or accessory which is liable to trap him — for example by the leg or the foot — as a result of the deflections of the structure.
4. TEST REPORT
- 4.1. The test report shall be attached to the EEC component type-approval certificate referred to in Annex VII. The presentation of the report shall be as shown in Annex V. The report shall include:
- 4.1.1. A general description of the protection structure's shape and construction (through drawings 1/20 scale for general drawings and 1/25 for attachment details) including materials and fastenings, external dimensions of the tractor with protection structure fitted, main interior dimensions and details of provisions for normal entry and exit and for escape, where they exist, and, where appropriate, details of the heating and ventilation system.
- 4.1.2. Details of any special features such as devices to prevent the continuous rolling of the tractor.
- 4.1.3. A brief description of any interior padding.
- 4.1.4. A statement of the type of windscreen and glazing fitted.
- 4.2. The report must clearly identify the tractor (make, type, trade name, etc.) used for testing and the other tractors for which the protection structure is intended.
- 4.3. If EEC component type-approval is being extended to other types of tractor, the report must include the exact reference of the report of the original EEC component type-approval as well as precise indications regarding the requirements laid down in Item 3.4 of Annex I.

A. APPARATUS AND EQUIPMENT FOR DYNAMIC TESTS

1. PENDULUM BLOCK
- 1.1. A pendulum block shall be suspended by two chains or wire ropes from pivot points not less than 6 meters above the ground. Means shall be provided for adjusting independently the suspended height of the block and the angle between the block and the supporting chains or wire ropes.
- 1.2. The mass shall be $2\,000 \pm 20$ kilograms excluding the mass of the chains or wire ropes which themselves shall not exceed 100 kilograms. The length of the sides of the impact face shall be 680 ± 20 mm (see Annex IV, Figure 4). The block shall be filled in such a way that the position of its centre of gravity is constant and coincides with the geometrical centre of the parallelepiped.
- 1.3. The parallelepiped shall be connected to the system which pulls it backwards by an instantaneous release mechanism which is so designed and located as to enable the pendulum block to be released without causing any significant oscillation of the parallelepiped.
2. PENDULUM SUPPORTS
- The pendulum pivot points shall be rigidly fixed so that their displacement in any direction does not exceed 1 % of the height of fall.
3. LASHINGS
- 3.1. The tractor shall be anchored to the ground by means of restraining and tensioning devices with rails rigidly attached to a non-yielding base. The rails shall be an appropriate width apart to enable the

tractor to be lashed in accordance with Annex IV, Figures 5, 6 and 7. During each test, the wheels of the tractor and the axle stands used shall rest on the non-yielding base.

- 3.2. The tractor shall be lashed to the rails by means of wire rope with round strand, fibre core, construction 6 × 19 in accordance with ISO 2408 and a nominal diameter of 13 mm. The metal strands shall have an ultimate tensile strength of 1 770 MPa.
- 3.3. The central pivot of an articulated tractor shall be supported and lashed down as appropriate for all tests. For the lateral impact test, the pivot shall also be propped from the side opposite the impact. The front and rear wheels need not be in line if this makes it more convenient to attach appropriate wire ropes.

4. WHEEL PROP AND BEAM

- 4.1. A softwood beam 150 mm square shall be used as a prop for the wheels during the lateral impact tests (see Annex IV, Figures 5, 6 and 7).
- 4.2. During the lateral impact tests, a softwood beam shall be clamped to the floor to brace the rim of the wheel opposite the side of impact as shown in Annex IV, Figure 7.

5. PROPS AND LASHINGS FOR ARTICULATED TRACTORS

- 5.1. Additional props and lashings shall be used for articulated tractors.
Their purpose is to ensure that the section of the tractor on which the protection structure is fitted is a rigid as that of a rigid tractor.
- 5.2. Additional specific details are given in Annex III A for the impact and crushing tests.

6. TYRE PRESSURE AND DEFLECTION

- 6.1. The tractor tyres shall not be liquid-ballasted and shall be inflated to the pressures prescribed by the tractor manufacturer for field work.
- 6.2. The lashings shall be tensioned in each particular case such that the tyres undergo a deflection equal to 12 % of the tyre wall height (distance between the ground and the lowest point of the rim) before tensioning.

7. CRUSHING RIG

A rig as shown in Annex IV, Figure 8, shall be capable of exerting a downward force on a protection structure through a rigid beam approximately 250 mm wide connected to the load-applying mechanism by means of universal joints. Suitable axle stands shall be provided so that the tractor tyres do not bear the crushing force.

8. MEASURING APPARATUS

- 8.1. A device such as that illustrated in Annex IV, Figure 9, for measuring the elastic deflection (the difference between the maximum momentary deflection and the permanent deflection).
- 8.2. A device for checking that the protection structure has not entered the zone of clearance and that the latter has remained within the structure's protection during the test (see Item 3.2.2 of Annex III A).

B. APPARATUS AND EQUIPMENT FOR STATIC TESTS

1. STATIC TESTING RIG

- 1.1. This rig shall enable horizontal thrusts or loading to be applied to the structure.
- 1.2. Provision must be made so that the load can be uniformly distributed normal to the direction of loading and along a beam having a length of one of the exact multiples of 50, between 250 and 700 mm.

The stiff beam shall have a vertical face dimension of 150 mm.

The edges of the beam in contact with the protection structure shall be curved, with a maximum radius of 50 mm.

- 1.3. The pad shall be capable of being adjusted to any angle in relation to the direction of the force, in order to be able to follow the angular variations of the structure's load-bearing surface as the structure deflects.
- 1.4. Direction of the force (deviation from horizontal and vertical)
 - at start of test, under zero load: $\pm 2^\circ$,
 - during test, under load: 10° above and 20° below the horizontal. These variations must be kept to a minimum.
- 1.5. The deflection rate shall be slow (less than 5 mm/s) so that the load may at all moments be considered as 'static'.

2. APPARATUS FOR MEASURING THE ENERGY ABSORBED BY THE STRUCTURE

- 2.1. The 'force versus deflection' curve shall be plotted in order to determine the energy absorbed by the structure. There is no need to measure the force and deflection at the point where the load is applied to the structure; however, 'force' and 'deflection' shall be measured simultaneously and co-linearly.
- 2.2. The point of origin of deflection measurements shall be selected such that only the energy absorbed by the structure and/or the deflection of certain parts of the tractor is taken into account. The energy absorbed by the deflection and/or the slipping of the anchoring shall be ignored.

3. MEANS OF ANCHORING THE TRACTOR TO THE GROUND

- 3.1. The tractor shall be anchored to the ground by means of restraining and tensioning devices with rails rigidly attached to a non-yielding base. The rails shall be an appropriate width apart to enable the tractor to be lashed. During each test, the wheels and the axle stands used shall rest on the base.
- 3.2. The tractor shall be anchored to the rails by any suitable means (plates, wedges, wire ropes, jacks, etc.) such that it cannot move during the tests. This requirement shall be checked while the loads are being applied, by means of the usual devices for measuring length. If the tractor moves, the entire test shall be repeated, unless the system for measuring the deflections used in plotting the 'force versus deflection' curve is connected to the tractor.

4. CRUSHING RIG

A rig as shown in Figure 8 of Annex IV shall be capable of exerting a downward force on a protection structure through a rigid beam approximately 250 mm wide connected to the load-applying mechanism by means of universal joints. Suitable axle stands shall be provided so that the tractor tyres do not bear the crushing force.

5. OTHER MEASURING APPARATUS

- 5.1. A device such as that illustrated in Figure 9 of Annex IV, for measuring the elastic deflection (the difference between the maximum momentary deflection and the permanent deflection).
- 5.2. A device for checking that the protection structure has not entered the zone of clearance and that the latter has remained within the structure's protection during the test (see Item 3.2.2 of Annex III B).

C. SYMBOLS

- m_t (kg) = tractor reference mass, as defined in Item 1.4 of Annex II.
- H (mm) = falling height of the pendulum block.

H' (mm)	=	falling height of the pendulum block for additional test.
L (mm)	=	tractor reference wheelbase.
I (kgm ²)	=	tractor reference moment of inertia in relation to the centre line of the rear wheels, notwithstanding the mass of these wheels.
D (mm)	=	deflection of the structure at the point of impact (dynamic tests) or at the point of and in line with the load application (static tests).
D' (mm)	=	deflection of the structure for the calculated energy required.
F (N)	=	static load force.
F_{\max} (N)	=	maximum static load force occurring during loading, with the exception of the overload.
F' (N)	=	force for calculated energy required.
F-D	=	force/deflection diagram.
E_{is} (J)	=	energy to be absorbed during the side loading.
E_{il} (J)	=	energy to be absorbed during longitudinal loading.
F_v (N)	=	vertical crushing force.

ANNEX III

TEST PROCEDURE

A. Dynamic tests

1. IMPACT AND CRUSHING TESTS

1.1. Impact at the rear

- 1.1.1. The tractor shall be so placed in relation to the pendulum block that the block will strike the protection structure when the impact face of the block and the supporting chains or wire ropes are at an angle with the vertical plane equal to $m_t/100$ with a 20° maximum, unless, during deflection, the protection structure at the point of contact forms a greater angle to the vertical. In this case the impact face of the block shall be adjusted by means of an additional support so that it is parallel to the protection structure at the point of impact at the moment of maximum deflection, the supporting chains or wire ropes remaining at the angle defined above.

The suspended height of the block shall be adjusted, and necessary steps taken so as to prevent the block from turning about the point of contact.

The point of impact shall be that part of the protection structure likely to hit the ground first in a rearward overturning accident, normally the upper edge. The position of the centre of gravity of the block shall be one-sixth of the width of the top of the protection structure inwards from a vertical plane parallel to the median plane of the tractor touching the outside extremity of the top of the protection structure.

If the structure is curved or protruding at this point, wedges enabling the impact to be applied thereon will have to be added, without thereby reinforcing the structure.

- 1.1.2. The tractor shall be lashed to the ground by means of four wire ropes, one at each end of both axles, arranged as indicated in Figure 5 of Annex IV. The front and rear lashing points shall be located at a distance such that the wire ropes make an angle of less than 30° with the ground. The rear lashings shall in addition be so arranged that the point of convergence of the two wire ropes is located in the vertical plane in which the centre of gravity of the block travels.

The wire ropes must be tensioned such that the tyres undergo the deflections given in Item 6.2 of Annex II A.

With the wire ropes tensioned, the wedging beam shall be placed in front of and tight against the rear wheels and then fixed to the ground.

- 1.1.3. If the tractor is of the articulated type, the point of articulation shall, in addition, be supported by a wooden block at least 100 mm square and firmly lashed to the ground.

- 1.1.4. The pendulum block shall be pulled back so that the height of its centre of gravity above that at the point of impact is given by one of the following two formulae:

$$H = 2,165 \times 10^{-8} m_t L^2 \text{ or } H = 5,73 \times 10^{-2} l.$$

The block must then be released so as to strike the protection structure.

1.2. Impact at the front

- 1.2.1. The tractor shall be so placed in relation to the pendulum block that the block will strike the protection structure when the impact face of the block and the supporting chains or wire ropes are at an angle with the vertical plane, equal to $m_t/100$ with a 20° maximum, unless, during deflection, the protection structure at the point of contact forms a greater angle to the vertical. In this case the impact face of the block shall be adjusted by means of an additional support so that it is parallel to the protection structure at the point of impact at the moment of maximum deflection, the supporting chains or wire ropes remaining at the angle defined above.

The suspended height of the pendulum block shall be adjusted and necessary steps taken so as to prevent the block from turning about the point of contact.

The point of impact shall be that part of the protection structure likely to hit the ground first if the tractor overturns sideways while travelling forward, normally the upper edge. The position of the

centre of gravity of the block shall be one-sixth of the width of the top of the protection structure inwards from a vertical plane parallel to the median plane of the tractor touching the outside extremity of the top of the protection structure.

If the structure is curved or protruding at this point, wedges enabling the impact to be applied thereon will have to be added, without thereby reinforcing the structure.

- 1.2.2. The tractor shall be lashed to the ground by means of four wire ropes, one at each end of both axles, arranged as indicated in Figure 6 of Annex IV. The front and rear lashing points shall be located at a distance such that the wire ropes make an angle of less than 30° with the ground. The rear lashings shall, in addition, be so arranged that the point of convergence of the two wire ropes is located in the vertical plane in which the centre of gravity of the pendulum block travels.

The wire ropes must be tensioned such that the tyres undergo the deflections given in Item 6.2 of Annex II A.

With the wire ropes tensioned, the wedging beam shall be placed firmly behind the rear wheels and then fixed to the ground.

- 1.2.3. If the tractor is of the articulated type, the point of articulation shall in addition be supported by a wooden block at least 100 mm square and firmly lashed to the ground.

- 1.2.4. The pendulum block shall be pulled back so that the height of its centre of gravity above that at the point of impact is given by one of the following two formulae, to be chosen according to the reference mass of the tractors subjected to the tests:

$$H = 25 + 0,07 m_t \text{ for tractors with a reference mass of less than 2 000 kilograms,}$$

$$H = 125 + 0,02 m_t \text{ for tractors with a reference mass of more than 2 000 kilograms.}$$

The pendulum block must then be released so as to strike the protection structure.

1.3. Impact from the side

- 1.3.1. The tractor shall be so placed in relation to the pendulum block that the block will strike the protection structure when the impact face of the weight and the supporting chains or wire ropes are vertical unless, during deflection, the protection structure at the point of contact forms an angle to the vertical. In this case the impact face of the block shall be adjusted by means of an additional support so that it is parallel to the protection structure at the point of impact at the moment of maximum deflection, the supporting chains or wire ropes remaining vertical on impact.

The suspended height of the block shall be adjusted and necessary steps taken so as to prevent the block from turning about the point of contact.

The point of impact shall be that part of the protection structure likely to hit the ground first in a sideways overturning accident, normally the upper edge. Unless it is certain that another part of this edge would hit the ground first, the point of impact shall be in the plane at right angles to the median plane and passing 200 mm in front of the seat reference point, the seat being set at the mid position of the longitudinal seat adjustment.

- 1.3.2. The tractor wheels on the side which is to receive the impact shall be lashed to the ground by means of wire ropes passing over the corresponding ends of the front and rear axles. The wire ropes shall be tensioned to produce the tyre deflection values given in Item 6.2 of Annex II A on the side which is to receive the impact.

With the wire ropes tensioned, the wedging beam shall be placed on the ground, pushed tight against the tyres on the side opposite that which is to receive the impact and then fixed to the ground. It may be necessary to use two beams or wedges if the outer sides of the front and rear tyres are not in the same vertical plane.

The prop shall then be placed as indicated in Figure 7 of Annex IV against the rim of the wheel opposite to the impact, pushed firmly against the rim and then fixed at its base.

The length of the rop shall be chosen such that it makes an angle of $30 \pm 3^\circ$ with the ground when in position against the rim. In addition, its length must, if possible, be between 20 and 25 times greater than its thickness and its width between two and three times greater than its thickness. The props shall be shaped at both ends as shown in the details of Figure 7 of Annex IV.

- 1.3.3. If the tractor is of the articulated type, the point of articulation shall, in addition, be supported by a wooden block at least 100 mm square and laterally supported by a device similar to that provided for in Item 1.3.2 against the rear wheel. The point of articulation shall then be lashed firmly to the ground.

- 1.3.4. The pendulum block shall be pulled back so that the height of its centre of gravity above that at the point of impact is given by one of the following two formulae, to be chosen according to the reference mass of the tractors subjected to the tests:

$$H = 25 + 0,20 m_t \text{ for tractors with a reference mass of less than 2 000 kilograms,}$$

$$H = 125 + 0,15 m_t \text{ for tractors with a reference mass of more than 2 000 kilograms.}$$

The pendulum block must then be released so as to strike the protection structure.

1.4. Crushing at the rear

The beam shall be positioned over the rear uppermost structural member(s) and the resultant of the crushing forces shall be located in the tractor's median plane.

A force, $F_v = 20 m_t$ shall be applied.

Where the rear part of the protection structure roof will not sustain the full crushing force, the force shall be applied until the roof is deflected to coincide with the plane joining the upper part of the protection structure with that part of the rear of the tractor capable of supporting the vehicle's mass when overturned.

The force shall then be removed, and the tractor or loading force repositioned so that the beam is over that point of the protection structure which would then support the tractor when completely overturned.

The force F_v shall then be applied.

It shall be applied for a minimum of five seconds following the cessation of any visually detectable deflection.

1.5. Crushing at the front

The beam shall be positioned over the front uppermost structural member(s) and the resultant of the crushing forces shall be located in the tractor's median plane.

A force, $F_v = 20 m_t$ shall be applied.

Where the front part of the protection structure roof will not sustain the full crushing force, the force shall be applied until the roof is deflected to coincide with the plane joining the upper part of the protection structure with that part of the front of the tractor capable of supporting the vehicle's mass when overturned.

The force shall then be removed, and the tractor or loading force repositioned so that the beam is over that point of the protection structure which would then support the tractor when completely overturned.

The force F_v shall then be applied.

It shall be applied for a minimum of five seconds following the cessation of any visually detectable deflection.

1.6. Additional tests

If cracks or tears which cannot be considered negligible appear during a crushing test, a second similar crushing test, but with a force equal to $1,2 F_v$, shall be applied immediately after the crushing test which caused the cracks or tears to appear.

2. ZONE OF CLEARANCE

- 2.1. The zone of clearance is shown in Figures 1, 2a, 2b, 2c, 2d and 2e of Annex IV.

The zone is defined on the basis of a 'vertical reference plane', generally longitudinal to the tractor and passing through the seat reference point and the centre of the steering wheel. This plane must be able to move horizontally with the seat and the steering wheel during the impact but to remain perpendicular to the floor of the tractor or of the protection structure if this is resiliently mounted.

- 2.2. The zone is bounded by the following planes, the tractor being on a horizontal surface and, where the steering wheel is adjustable, its position adjusted for normal seated driving.

- 2.2.1. A horizontal plane — $A_1B_1B_2A_2$ — 900 mm above the seat reference point.

- 2.2.2. An inclined plane — $H_1H_2G_2G_1$ — perpendicular to the vertical reference plane and including a point 900 mm directly above the seat reference point and the rearmost point of the seat backrest.
- 2.2.3. A cylindrical surface — $A_1A_2H_2H_1$ — which is perpendicular to the reference plane, has a radius of 120 mm and is tangential to the planes defined above in Items 2.2.1 and 2.2.2.
- 2.2.4. A cylindrical surface — $B_1C_1C_2B_2$ — perpendicular to the reference plane, having a radius of 900 mm and extending forward by 400 mm the plane defined in Item 2.2.1 above, to which it is tangential, following a horizontal line 150 mm forward of the seat reference point.
- 2.2.5. A inclined plane — $C_1D_1D_2C_2$ — perpendicular to the reference plane, extending the surface defined in Item 2.2.4 above and passing through a point 40 mm from the outer edge of the steering wheel.
- 2.2.6. A vertical plane — $D_1K_1E_1E_2K_2D_2$ — perpendicular to the reference plane and passing 40 mm in front of the other edge of the steering wheel.
- 2.2.7. A horizontal plane — $E_1F_1P_1N_1N_2P_2F_2E_2$ — passing through the seat reference point.
- 2.2.8. A curvilinear surface — $G_1L_1M_1N_1N_2M_2L_2G_2$ — perpendicular to the reference plane and in contact with the back of the seat backrest.
- 2.2.9. Two vertical planes — $K_1I_1F_1E_1$ and $K_2I_2F_2E_2$ — parallel to the reference plane, 250 mm either side of this plane, and bounded towards the top 300 mm above the horizontal plane passing through the seat reference point.
- 2.2.10. Two inclined and parallel planes — $A_1B_1C_1D_1K_1I_1L_1G_1H_1$ and $A_2B_2C_2D_2K_2I_2L_2G_2H_2$ — starting from the upper edge of the planes defined in Item 2.2.9 above and joining the horizontal plane defined in Item 2.2.1 above at least 100 mm from the reference plane on the side where the impact is applied.
- 2.2.11. Two vertical planes — $Q_1P_1N_1M_1$ and $Q_2P_2N_2M_2$ — parallel to the reference plane, 200 mm either side of this plane, and bounded towards the top 300 mm above the horizontal plane passing through the seat reference point.
- 2.2.12. Two portions — $I_1Q_1P_1F_1$ and $I_2Q_2P_2F_2$ — of a vertical plane, perpendicular to the reference plane and passing 350 mm in front of the seat reference point.
- 2.2.13. Two portions — $I_1Q_1M_1L_1$ — and $I_2Q_2M_2L_2$ — of the horizontal plane passing 300 mm above the seat reference point.

2.3. Seat location and seat reference point

2.3.1 *Seat reference point*

- 2.3.1.1. The reference point shall be established using the apparatus illustrated in Figures 3 and 3b of Annex IV. The apparatus shall consist of a seat pan board and backrest boards. The lower backrest board shall be jointed in the region of the ischium humps (A) and loin (B), the joint (B) being adjustable in height.
- 2.3.1.2. The reference point is defined as the point in the median longitudinal plane of the seat where the tangential plane of the lower backrest and a horizontal plane intersect. This horizontal plane cuts the lower surface of the seat pan board 150 mm in front of the abovementioned tangent.
- 2.3.1.3. The apparatus shall be positioned on the seat. It shall then be loaded with a force of 550 N at a point 50 mm in front of joint (A), and the two parts of the backrest board shall be lightly pressed tangentially against the backrest.
- 2.3.1.4. If it is not possible to determine definite tangents to each area of the backrest (above and below the lumbar region) the following must be done:
 - 2.3.1.4.1. Where no definite tangent to the lower area is possible the lower part of the backrest board is pressed against the backrest vertically.
 - 2.3.1.4.2. Where no definite tangent to the upper area is possible the joint (B) is fixed at a height of 230 mm above the lower surface of the seat pan board, the backrest board being perpendicular to the latter. Then the two parts of the backrest board are lightly pressed against the backrest.

2.3.2. *Seat position and adjustment for determining the location of the seat reference point*

- 2.3.2.1. Where the seat position is adjustable, the seat must be adjusted to its rear uppermost position.
- 2.3.2.2. Where the inclination of the backrest and seat pan is adjustable, these must be adjusted so that the reference point is in its rear uppermost position.
- 2.3.2.3. Where the seat is equipped with suspension, the latter must be blocked at mid-travel, unless this is contrary to the instructions clearly laid down by the seat manufacturer.

3. MEASUREMENTS TO BE MADE

3.1. Fractures and cracks

After each test all structural members, joints and fastening systems shall be visually examined for fractures or cracks, any small cracks in unimportant parts being ignored.

Any tears caused by the edges of the pendulum weight shall be ignored.

3.2. Zone of clearance

3.2.1. During each test an examination shall be made to see whether any part of the protection structure has entered the zone of clearance round the driver's seat as defined in Item 2 of this Annex.

3.2.2. In addition, an examination shall be made to determine whether any part of the zone of clearance is outside the protection of the protection structure. For this purpose it shall be considered to be outside the protection of the roll-over protection structure if any part of it would have come into contact with flat ground if the tractor had overturned towards the direction from which the impact came. For this purpose the front and rear tyre and track setting shall be assumed to be the smallest specified by the manufacturer.

3.3. Elastic deflection (on side impact)

The elastic deflection shall be measured 900 mm above the seat reference point, in the vertical plane passing through the point of impact. For this measurement, apparatus as shown in Figure 9 of Annex IV shall be used.

3.4. Permanent deflection

After the final crushing test, the permanent deflection of the protection structure shall be recorded. For this purpose, before the start of the test, the position of the main protection structure members in relation to the seat reference point shall be recorded.

B. Static tests**1. LOADING AND CRUSHING TESTS****1.1. Loading at the rear**

1.1.1. The load shall be applied horizontally, in a vertical plane parallel to the tractor's median plane.

The load application point shall be that part of the protection structure likely to hit the ground first in a rearward overturning accident, normally the upper edge. The vertical plane in which the load is applied shall be located at a distance of one-third of the external width of the upper part of the structure from the median plane.

If the structure is curved or protruding at this point, wedges enabling the load to be applied thereon will have to be added, without thereby reinforcing the structure.

1.1.2. The assembly defined in Item 1.3.1 of Annex II shall be lashed to the ground as described in Item 3 of Annex II B.

1.1.3. The energy absorbed by the protection structure during the test shall be at least

$$E_{ij} = 2,165 \times 10^{-7} m_t L^2 \text{ or } E_{ij} = 0,574 \times I.$$

1.2. Loading at the front

1.2.1. The load shall be applied horizontally in a vertical plane parallel to the tractor's median plane.

The point of application shall be that part of the protection structure likely to hit the ground first if the tractor overturns sideways while travelling forward, i.e. normally the upper edge. The point of application of the load shall be one-sixth of the width of the top of the protection structure inwards from a vertical plane parallel to the median plane of the tractor touching the outside extremity of the top of the protection structure.

If the structure is curved or protruding at this point, wedges enabling the load to be applied thereon will have to be added, without thereby reinforcing the structure.

1.2.2. The assembly defined in Item 1.3.1 of Annex II shall be anchored to the ground as described in Item 3 of Annex II B.

1.2.3. The energy absorbed by the protection structure during the test shall be at least

$$E_{ij} = 500 + 0,5 m_t$$

1.3. Loading from the side

1.3.1. The side loading shall be applied horizontally, in a vertical plane perpendicular to the tractor's median plane and passing 200 mm in front of the seat reference point, the seat being at the mid position of the longitudinal seat adjustment.

The load application point shall be that part of the protection structure likely to hit the ground first in a sideways overturning accident, normally the upper edge.

1.3.2. The assembly defined in Item 1.3.1 of Annex II shall be lashed to the ground as described in Item 3 of Annex II B.

1.3.3. The energy absorbed by the protection structure during the test shall be at least

$$E_{is} = 1,75 m_t$$

1.4. Crushing at the rear

All provisions are identical to those given in Item 1.4 of Annex III A.

1.5. Crushing at the front

All provisions are identical to those given in Item 1.5 of Annex III A.

1.6. Overload test

1.6.1. An overload test shall be carried out where the force decreases by more than 3 % during the last 5 % of the deflection reached when the energy required is absorbed by the structure (see Figure 10b of Annex IV).

- 1.6.2. The overload test involves the gradual increase of the horizontal load by increments of 5 % of the initial energy requirement up to a maximum of 20 % of energy added (see Figure 10c of Annex IV).
- 1.6.2.1. The overload test is satisfactory if, after each increase by 5 %, 10 % or 15 % in the energy required, the force decreases by less than 3 % for a 5 % increment and remains more than $0,8 F_{\max}$.
- 1.6.2.2. The overload test is satisfactory if, after the structure has absorbed 20 % of the added energy, the force exceeds $0,8 F_{\max}$.
- 1.6.2.3. Additional cracks or tears and/or entry into or lack of protection of the zone of clearance due to elastic deflection are permitted during the overload test. However, after the removal of the load, the structure shall not enter the zone of clearance, which shall be completely protected.

1.7. **Crushing test**

If cracks or tears which cannot be considered as negligible appear during a crushing test, a second, similar crushing, but with a force of $1,2 F_v$, shall be applied immediately after the crushing which caused the cracks or tears to appear.

2. **ZONE OF CLEARANCE**

The zone of clearance is identical to that described in Item 2 of Annex III A above, except that the word 'impact' is to be replaced by 'load' in the last line of Item 2.2.10.

3. **MEASUREMENTS TO BE MADE**

3.1. **Fractures and cracks**

After each test all structural members, joints and attachment systems shall be visually examined for fractures or cracks, any small cracks in unimportant parts being ignored.

3.2. **Zone of clearance**

- 3.2.1. During each test an examination shall be made to see whether any part of the protection structure has entered the zone of clearance as defined in Item 2 above.

- 3.2.2. In addition, an examination shall be made to determine whether any part of the zone of clearance is outside the protection of the protection structure. For this purpose it shall be considered to be outside the protection of the protection structure if any part of it would have come into contact with flat ground if the tractor had overturned towards the direction from which the impact came. For this purpose the front and rear tyres and track setting shall be assumed to be the smallest specified by the manufacturer.

3.3. **Elastic deflection (under side loading)**

The elastic deflection shall be measured 900 mm above the reference point, in the vertical plane in which the load is applied. For this measurement, any apparatus similar to that illustrated in Figure 9 of Annex IV, may be used.

3.4. **Permanent deflection**

After the tests, the permanent deflection of the protection structure shall be recorded. For this purpose, before the start of the tests, the position of the main protection structure members in relation to the seat reference point shall be recorded.

ANNEX IV

FIGURES

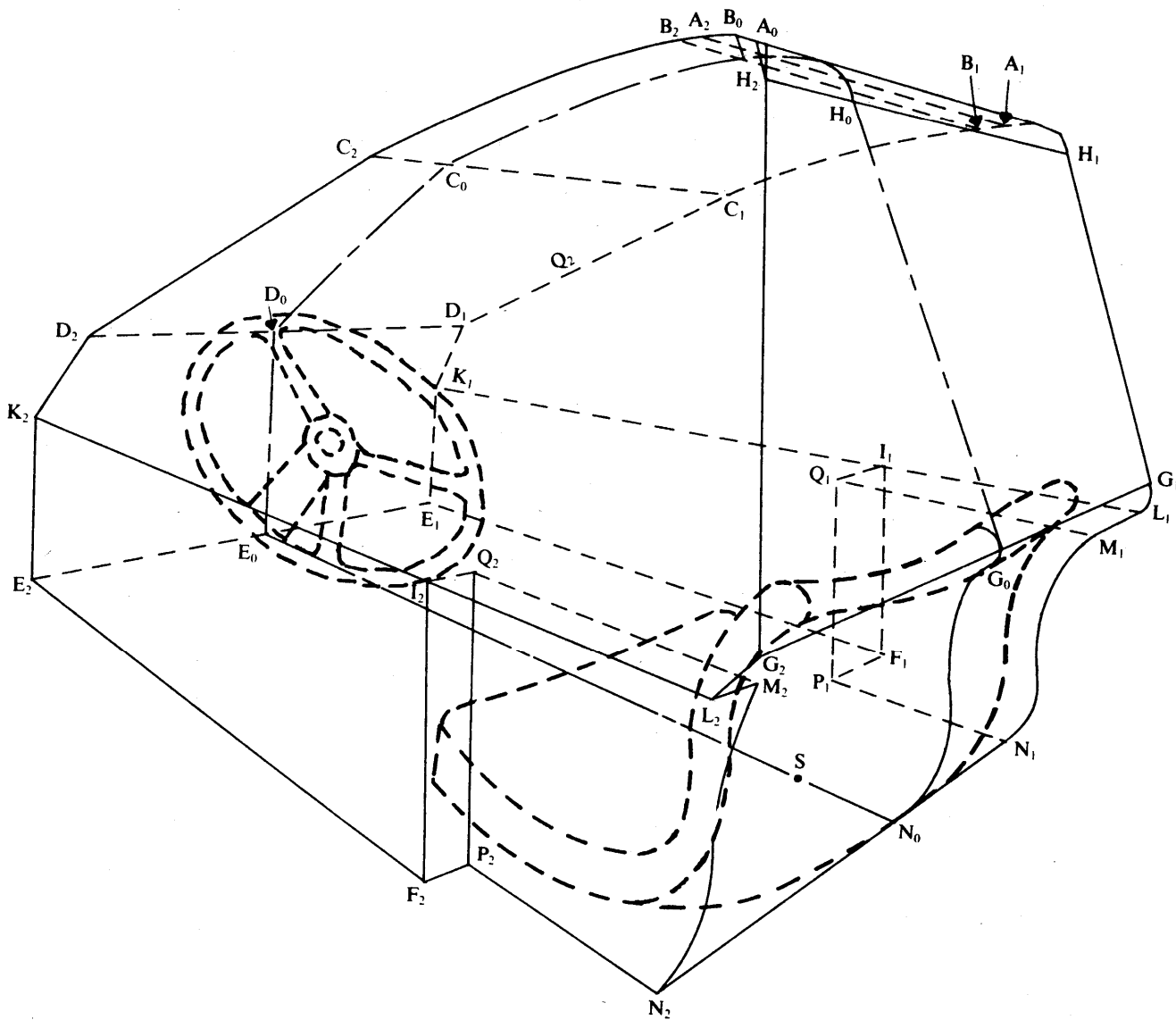

Figure 1

Zone of clearance — $\frac{3}{4}$ rear perspective view

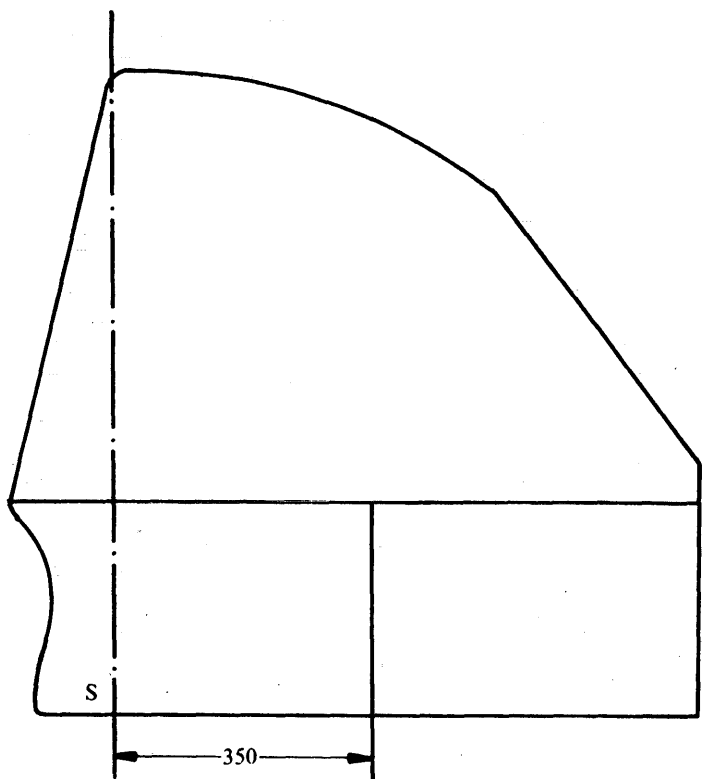

Figure 2b

Zone of clearance — Side view

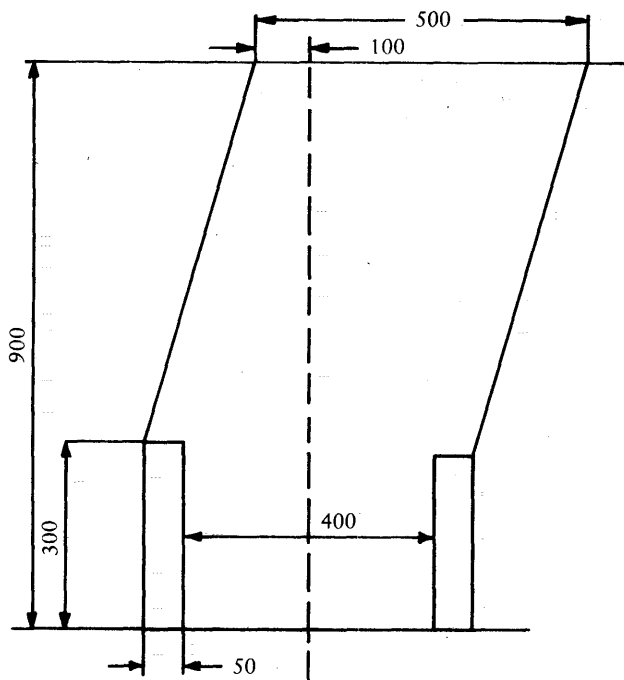

Figure 2c

Zone of clearance — Rear view

ZONE OF CLEARANCE

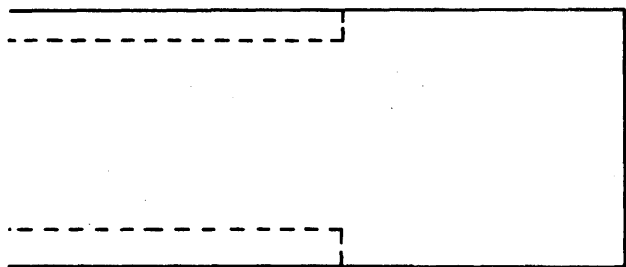

Figure 2d

Zone of clearance — Top view

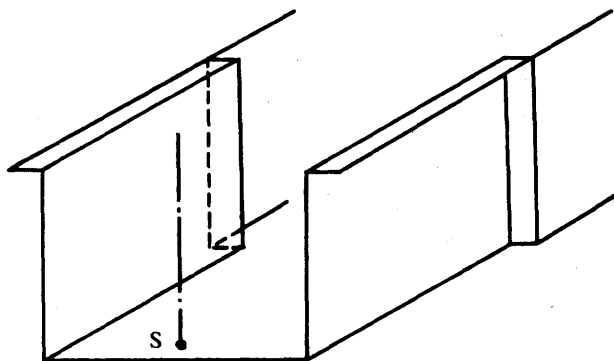

Figure 2e

Lower part of the zone of clearance — 3/4 rear view

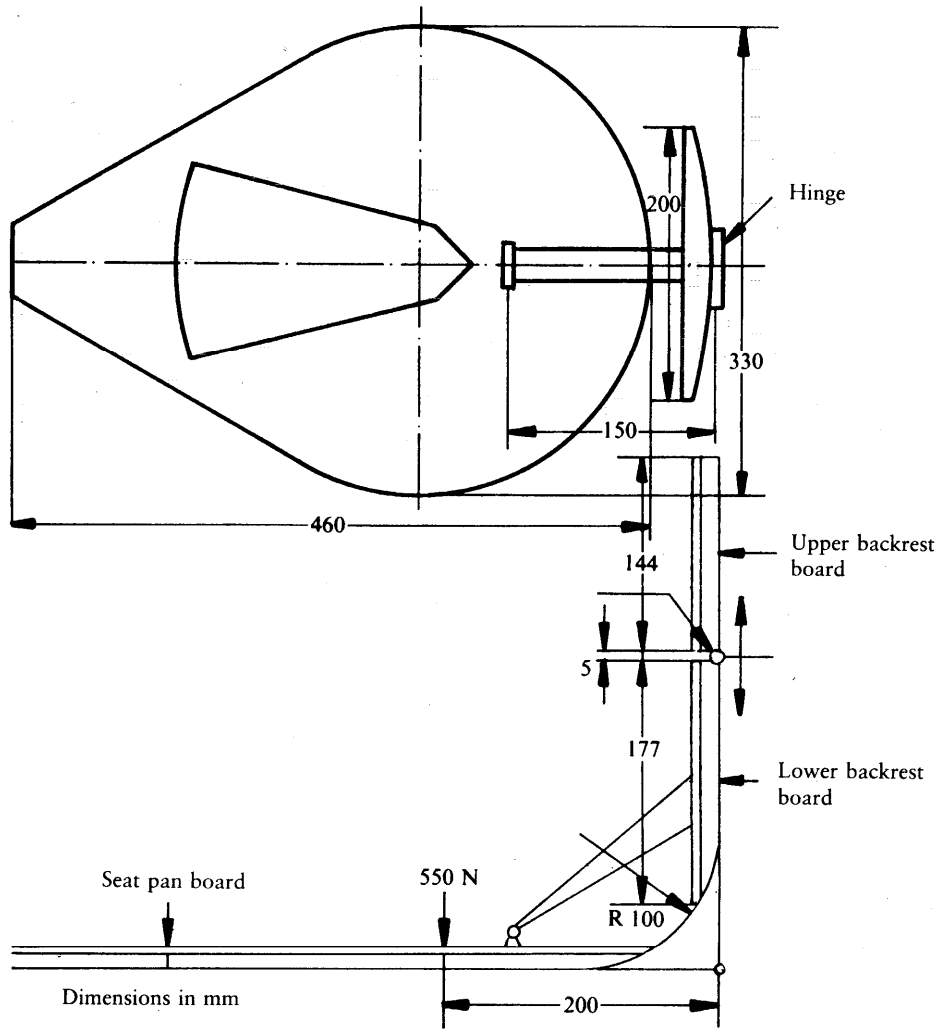

Figure 3a

Apparatus for determination of seat reference point

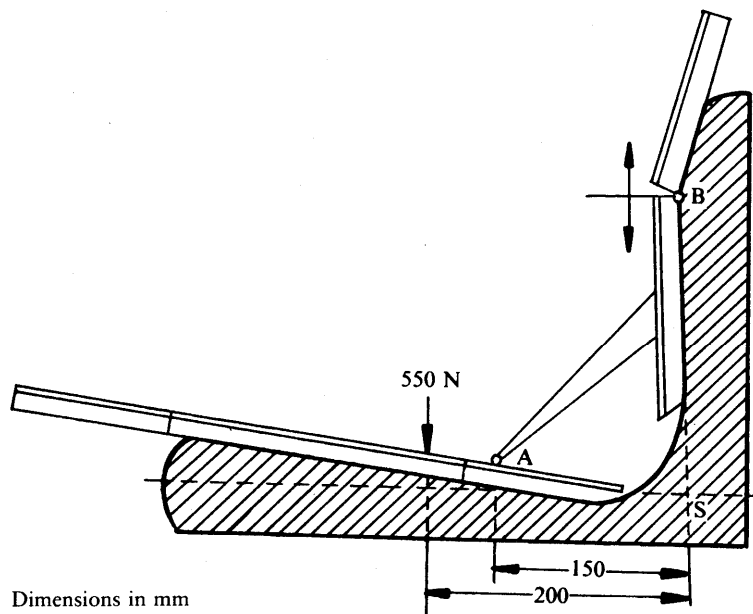

Figure 3b

Method of determining seat reference point

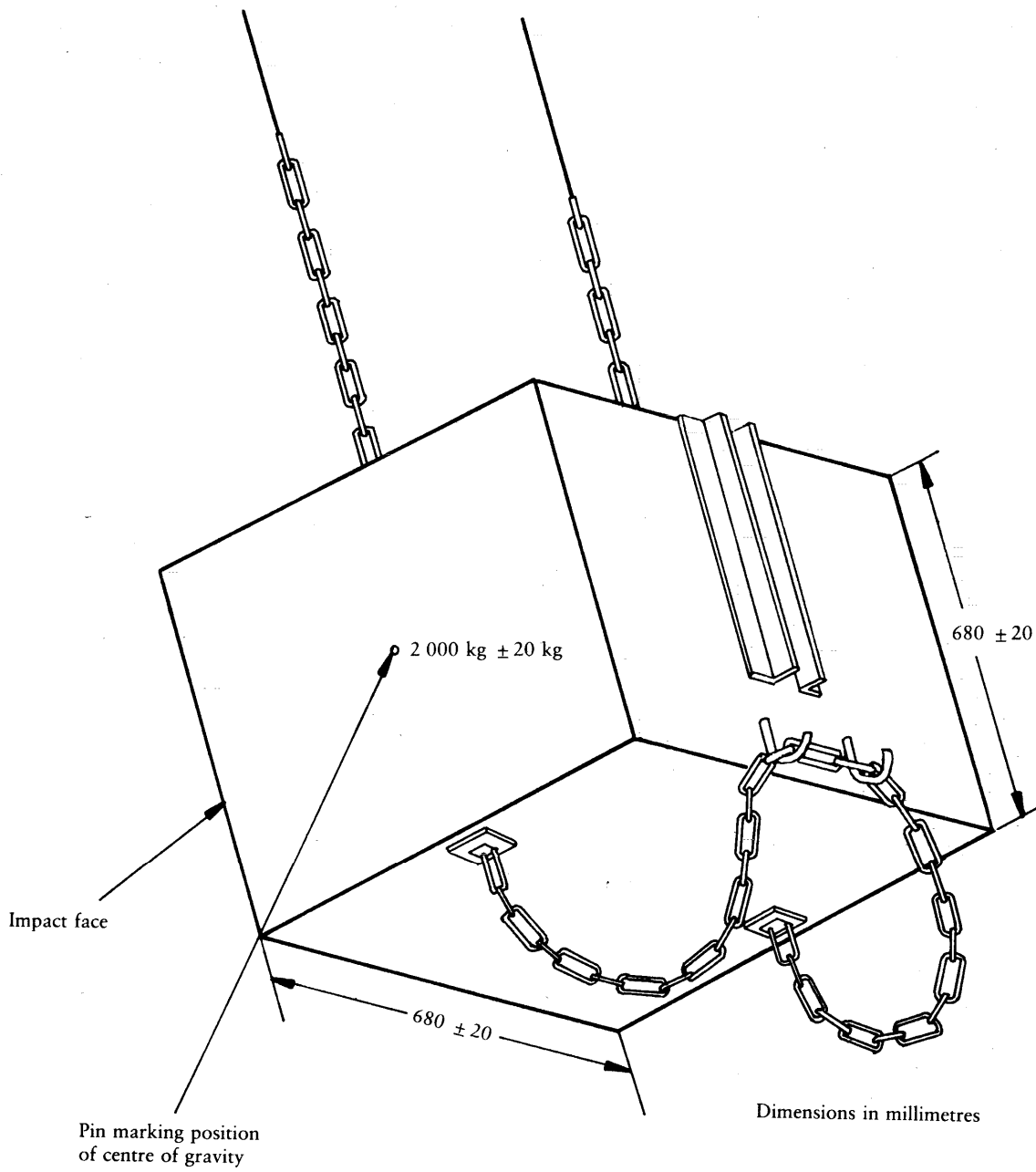

Figure 4

Pendulum block and its suspending chains or wire ropes

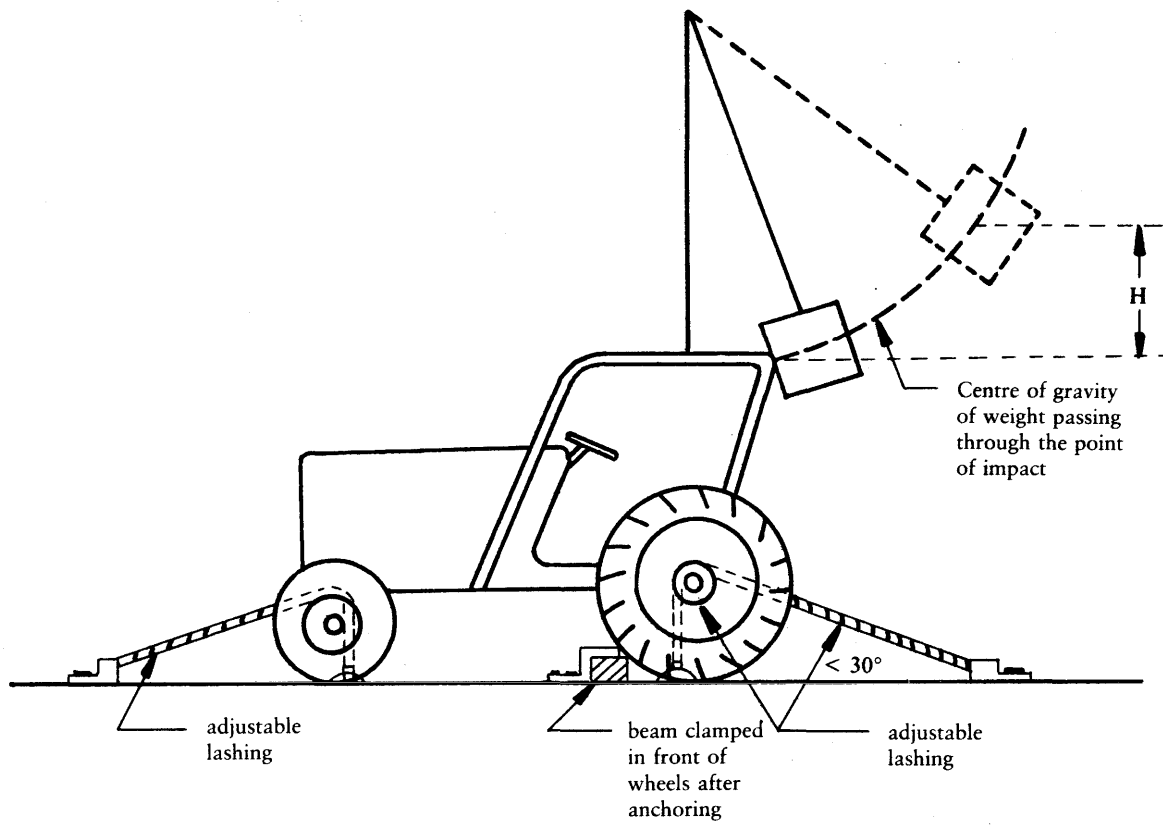

Figure 5

Impact at the rear

Note:

The configuration of the protection structure shown is solely for the purpose of illustration and for dimensional reference. It does not purport to denote design requirements.

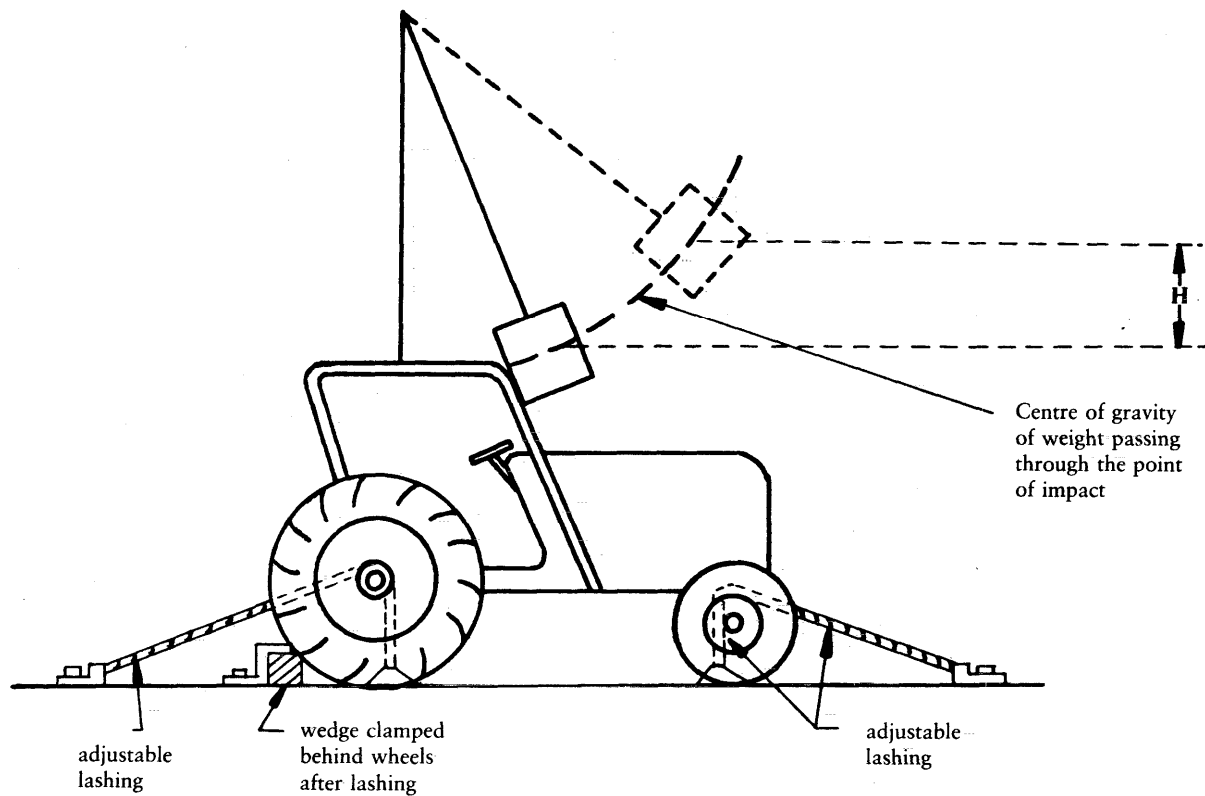

Figure 6

Impact at the front

Note:

The configuration of the protection structure shown is solely for the purpose of illustration and for dimensional reference. It does not purport to denote design requirements.

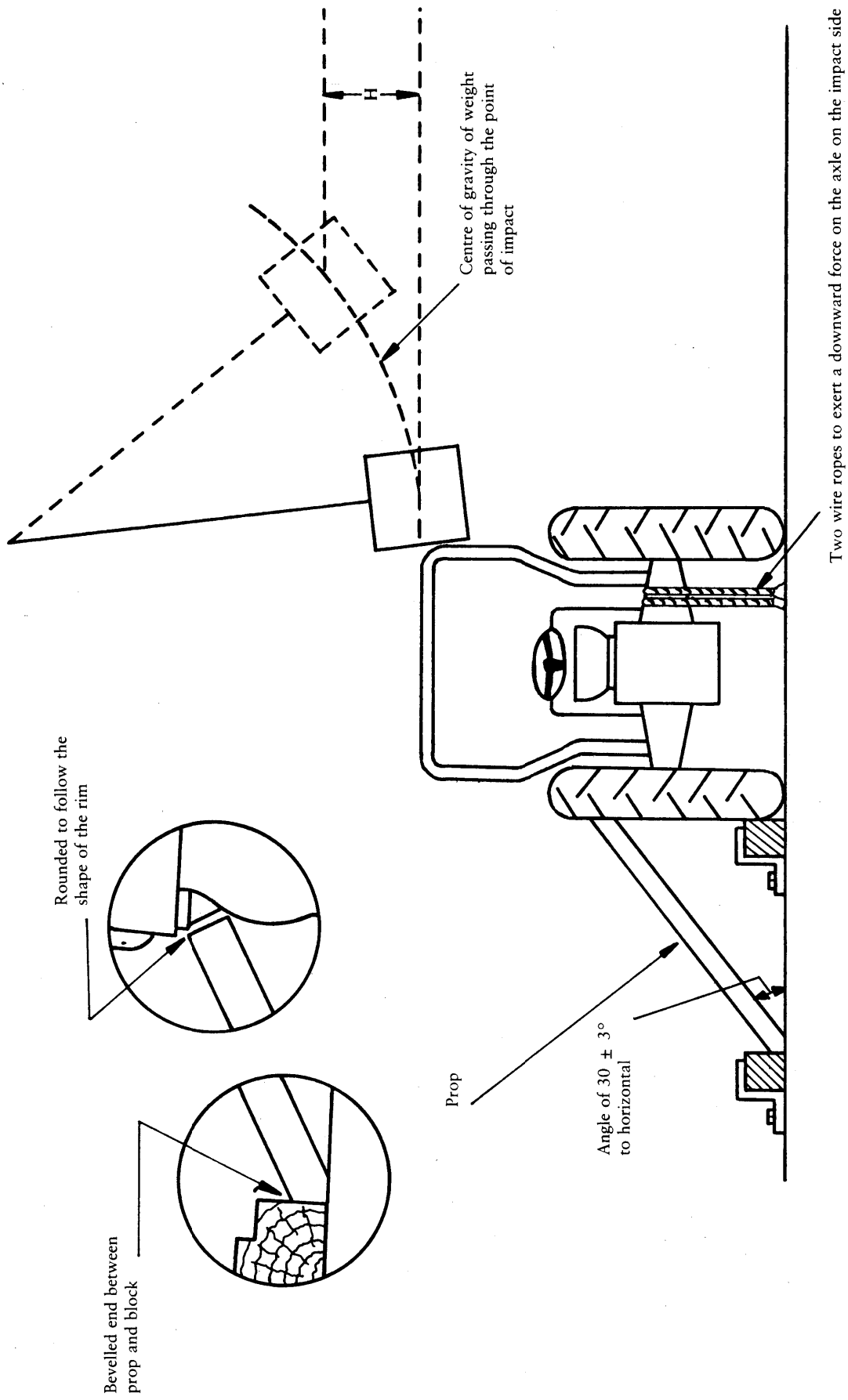
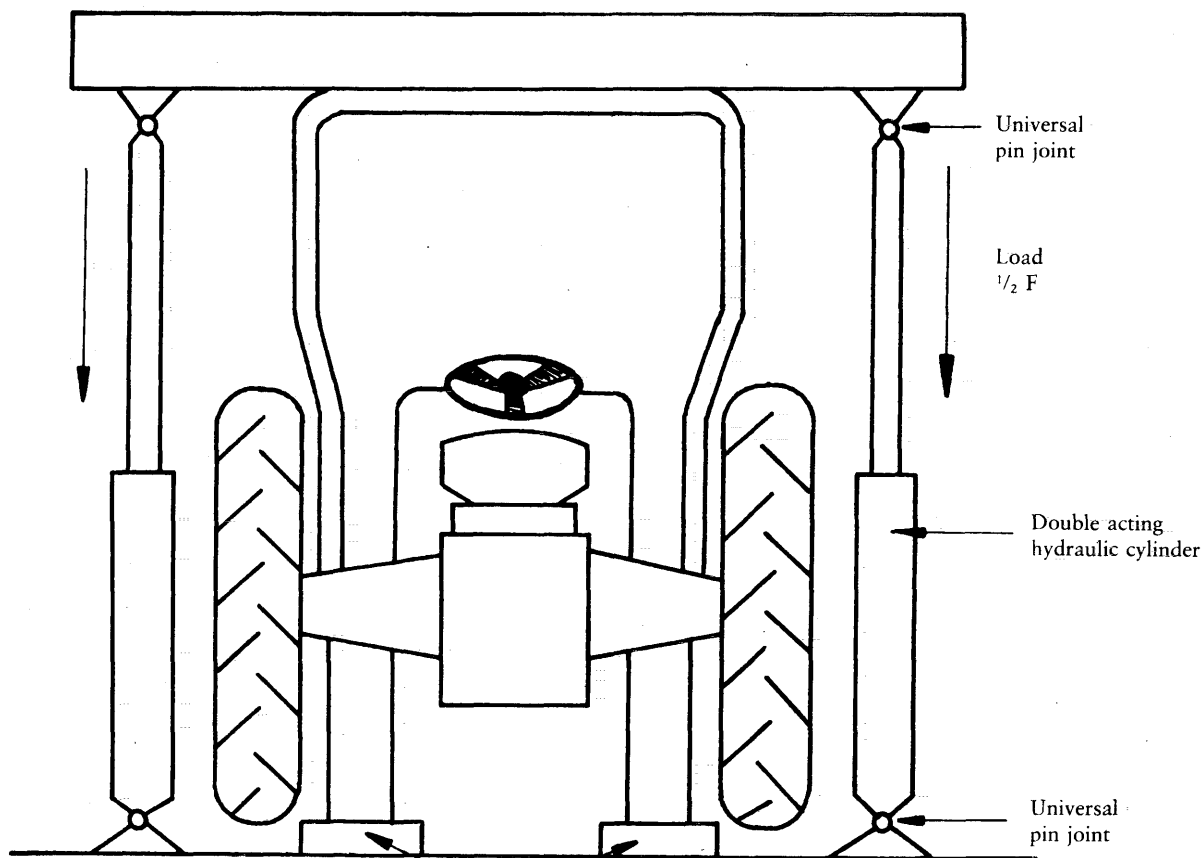

Figure 7

Impact from side

Note:

The configuration of the protection structure shown is solely for the purpose of illustration and for dimensional reference. It does not purport to denote design requirements.



Supports under front and rear axles

Figure 8

Crushing test

Note:

The configuration of the roll-over protection structure shown is solely for the purpose of illustration and for dimensional reference. It does not purport to denote design requirements.

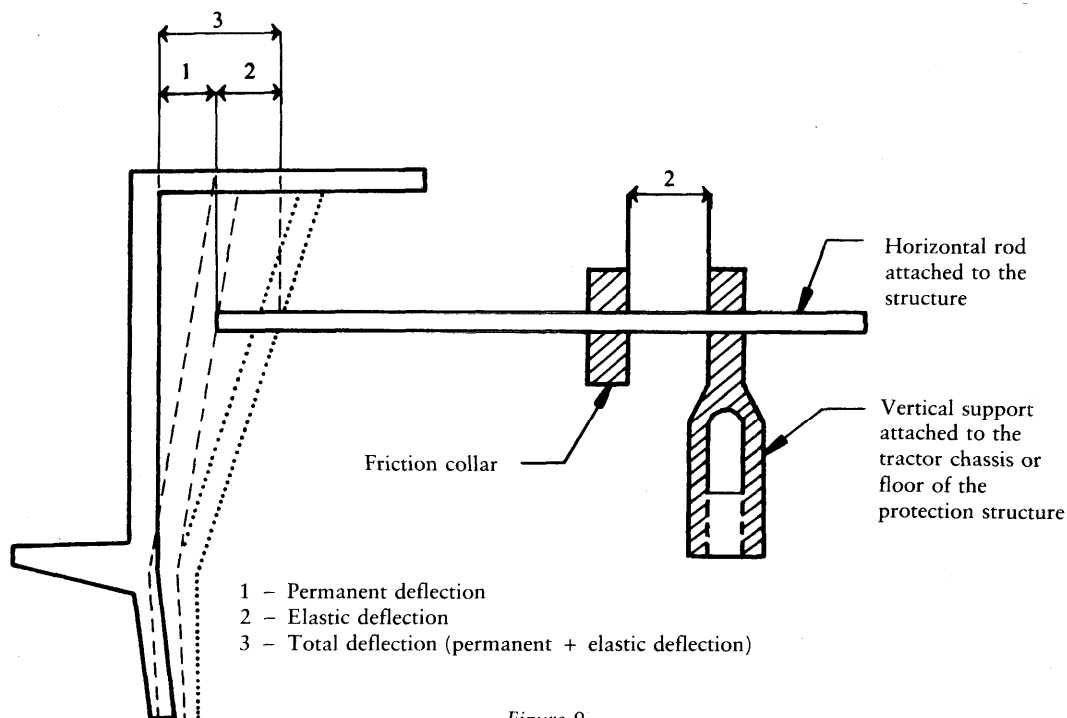

- 1 - Permanent deflection
- 2 - Elastic deflection
- 3 - Total deflection (permanent + elastic deflection)

Figure 9

Example of apparatus for measuring elastic deflection

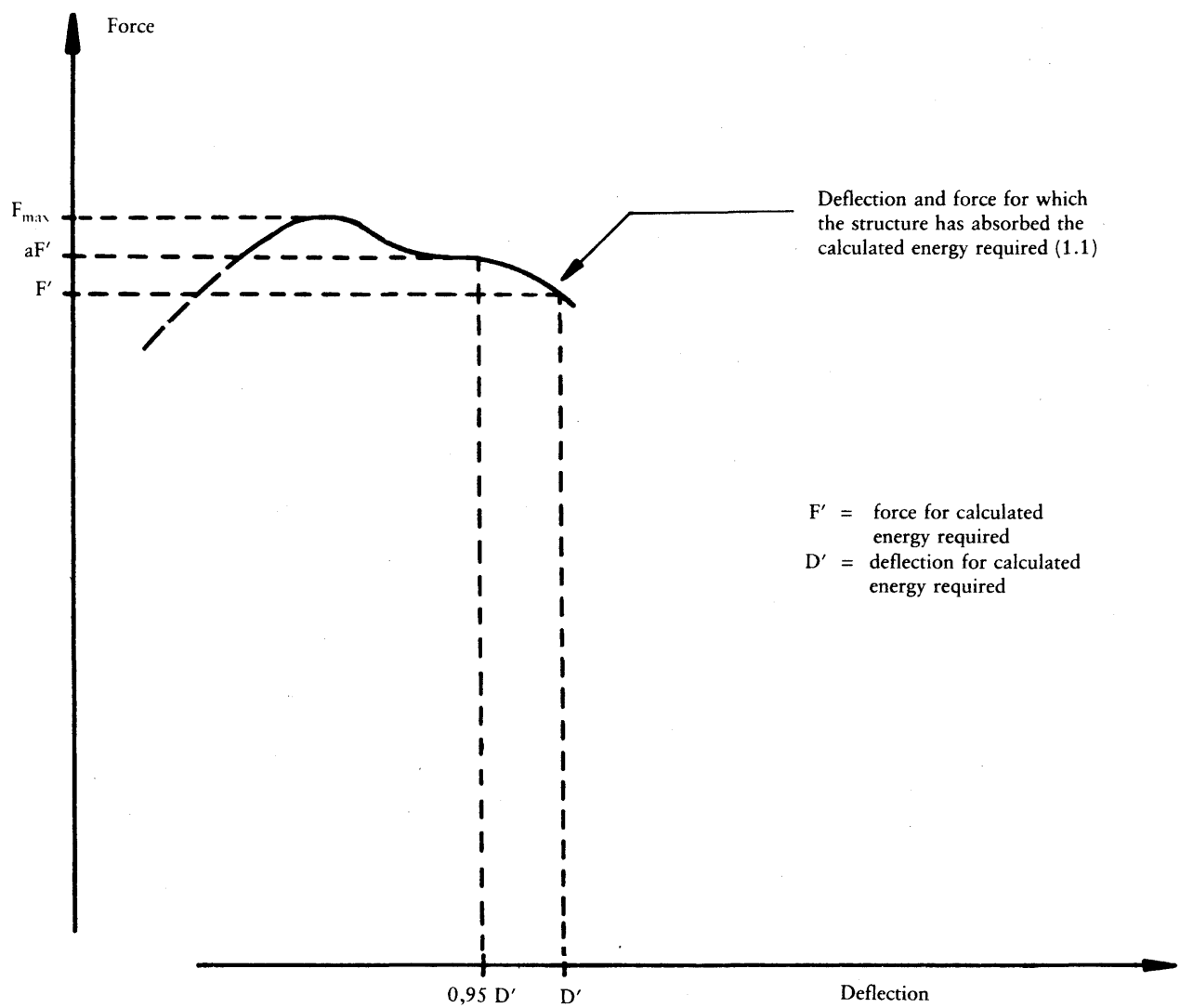

- 1. Reference aF' corresponding to $0,95 D'$.
- 1.1. Overload test not necessary since $aF' < 1,03 F'$.

Figure 10a

Force/Deflection curve
Overload test not necessary

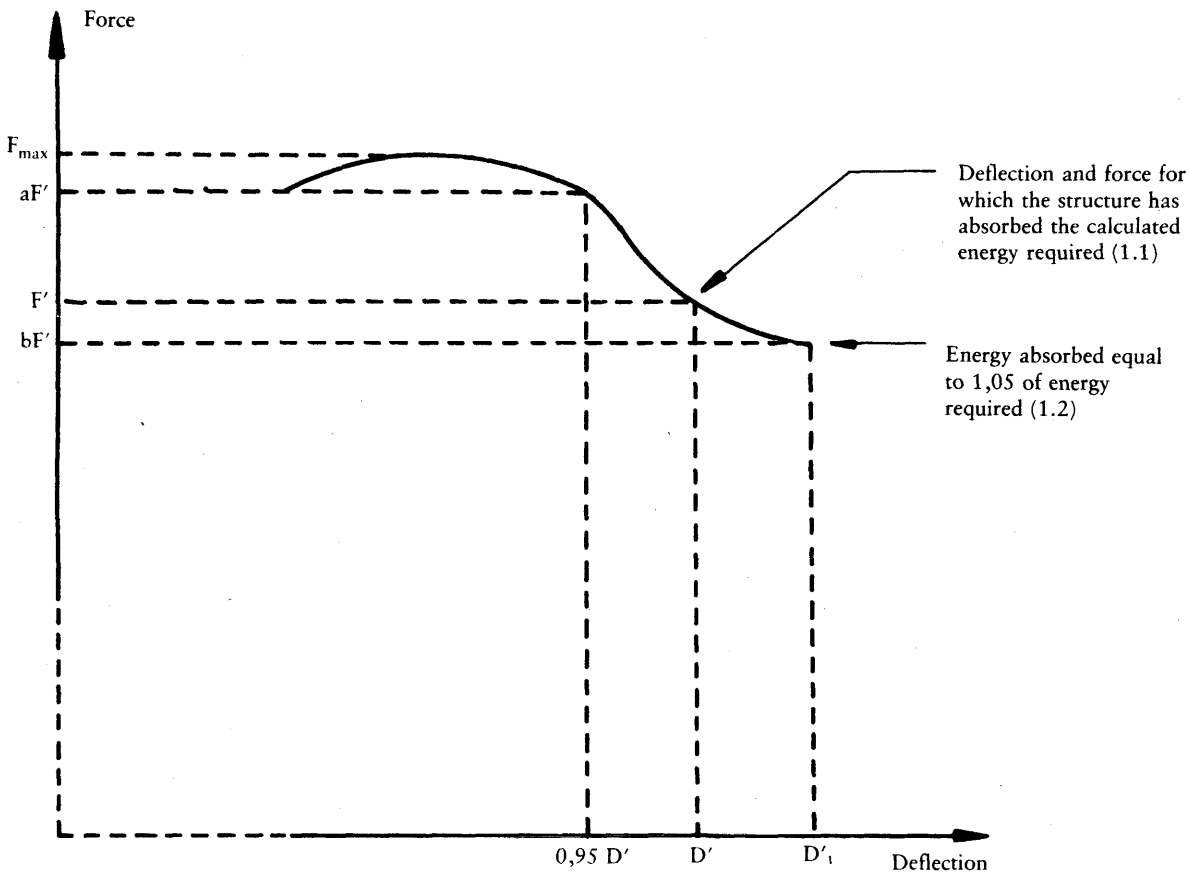

- 1. Reference aF' corresponding to $0,95 D'$
- 1.1. Overload test necessary since $aF' > 1,03 F'$
- 1.2. Overload test satisfactory since $bF' > 0,97 F'$ and $bF' > 0,8 F_{max}$

Figure 10b

Force/Deflection curve
Overload test necessary

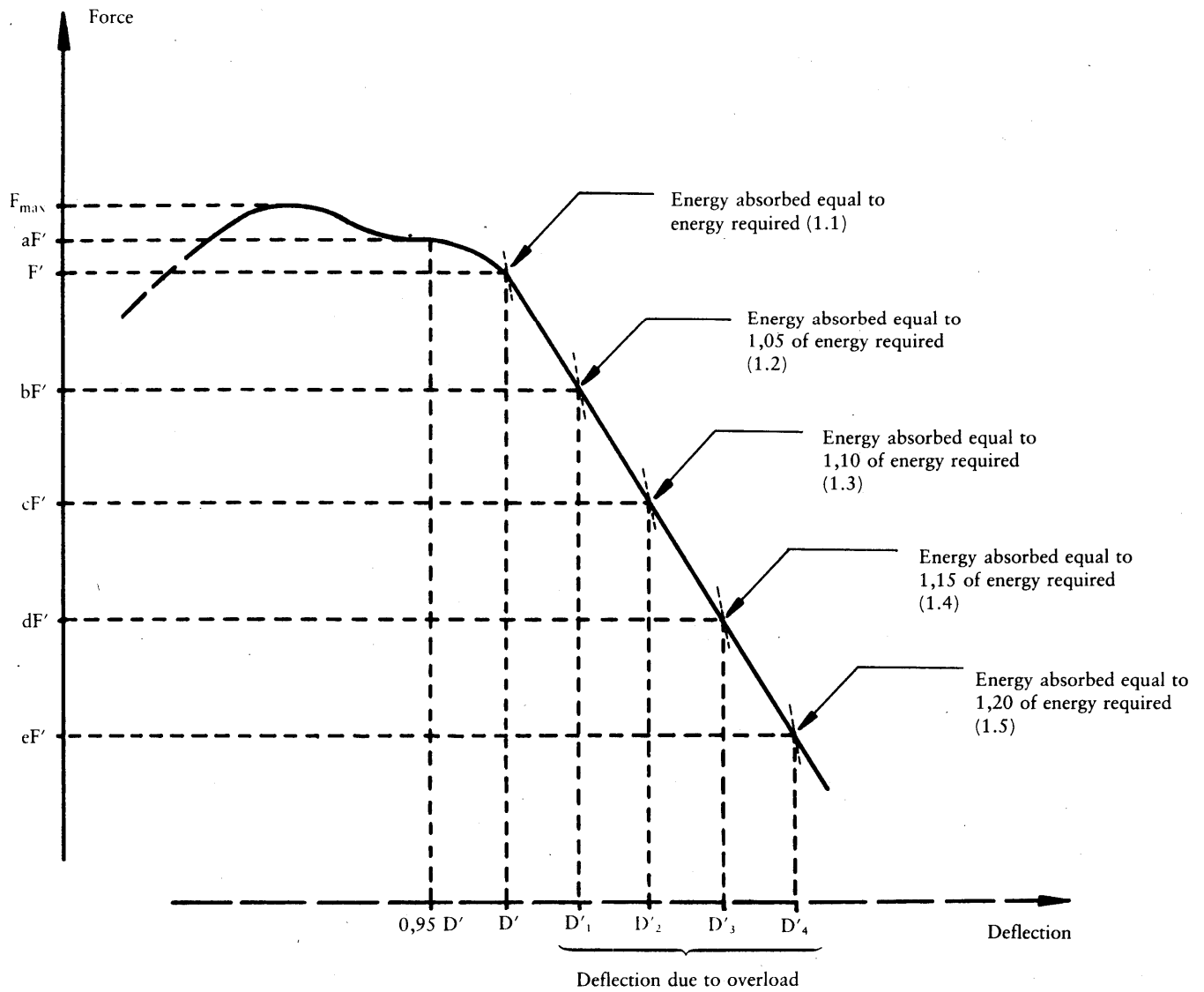

- 1.4 Reference aF' corresponding to $0,95 D'$.
- 1.1. Overload test necessary since $aF' > 1,03 F'$.
- 1.2. Since $bF' < 0,97 F'$, overload test to be continued.
- 1.3. Since $cF' < 0,97 bF'$, overload test to be continued.
- 1.4. Since $dF' < 0,97 cF'$, overload test to be continued.
- 1.5. Overload test satisfactory since $eF' > 0,8 F_{maximum}$.

Remark:

If at any moment F falls below $0,8 F_{max}$ the structure will be refused

Figure 10c

Force/Deflection curve
Overload test to be continued

ANNEX V

MODEL

REPORT RELATING TO THE EEC COMPONENT TYPE-APPROVAL TESTS OF A PROTECTION STRUCTURE (REAR-MOUNTED ROLLBAR, FRAME OR CAB) WITH REGARD TO ITS STRENGTH AS WELL AS TO THE STRENGTH OF ITS ATTACHMENT TO THE TRACTOR

Protection structure		
Make and type		
Tractor		Identification of test station
Make		
Type and commercial description		
Test method	Dynamic/static ⁽¹⁾	

EEC component type-approval No:

1. Trade mark or name and type of protection structure:

2. Name and address of manufacturer of tractor or protection structure:

3. If applicable, name and address of tractor or protection structure manufacturer's authorized representative:

4. Specifications of tractor on which the tests are carried out

4.1. Trade mark or name:

4.2. Type and commercial description:

4.3. Serial number:

4.4. Mass of unballasted tractor with protection structure fitted, without driver: kg

4.5. Wheelbase/moment of inertia ⁽¹⁾: mm/kgm² ⁽¹⁾

4.6. Tyre sizes: front:
 rear:

5. Extension of EEC component type-approval to other tractor types

5.1. Trade mark or name:

5.2. Type and commercial description:

5.3. Mass of unballasted tractor, with protection structure fitted, without driver:kg

⁽¹⁾ Delete where inapplicable.

- 5.4. Wheelbase/moment of inertia ⁽¹⁾: mm/kgm² ⁽¹⁾
- 5.5. Type sizes: front:
rear:
6. **Specifications of protection structure**
- 6.1. General arrangement drawing of both the protection structure and its attachment to the tractor.
- 6.2. Photographs from side and rear showing mounting details.
- 6.3. Brief description of protection structure including type of construction, details of mounting on the tractor, details of cladding, means of access and escape, details of interior padding, features to prevent continuous rolling and details of heating and ventilation.
- 6.4. *Dimensions*
- 6.4.1. Height of roof members above the seat reference point: mm
- 6.4.2. Height of roof members above the tractor foot platform: mm
- 6.4.3. Interior width of the protection structure 900 mm above the seat reference point: mm
- 6.4.4. Interior width of the protection structure at a point above the seat at the height of the centre of the steering wheel: mm
- 6.4.5. Distance from the centre of steering wheel to the right-hand side of roll-over protection structure: mm
- 6.4.6. Distance from the centre of the steering wheel to the left-hand side of roll-over protection structure: mm
- 6.4.7. Minimum distance from the steering wheel rim to the roll-over protection structure: mm
- 6.4.8. Width of the doorways:
at the top: mm
in the middle: mm
at the bottom: mm
- 6.4.9. Height of the doorways:
above foot platform: mm
above highest mounting step: mm
above lowest mounting step: mm
- 6.4.10. Overall height of the tractor with the protection structure fitted: mm
- 6.4.11. Overall width of the protection structure: mm
- 6.4.12. Horizontal distance to the rear of the protection structure from the back of the seat at a height of 900 mm above the seat reference point: mm
- 6.5. Details and quality of materials used, standards used:
- Main frame: (material and dimensions)
- Mountings: (material and dimensions)
- Cladding: (material and dimensions)
- Roof: (material and dimensions)
- Interior padding: (material and dimensions)
- Assembly and mounting bolts: (grade and dimensions)

⁽¹⁾ Delete where inapplicable.

7. Test results

7.1. Impact/load ⁽¹⁾ and crushing tests

Impact/load ⁽¹⁾ tests were made to the left/right-hand ⁽¹⁾ rear and to the right/left-hand ⁽¹⁾ front and right/left-hand side ⁽¹⁾. The reference mass used for calculating impact energies/the load ⁽¹⁾ and crushing forces was..... kg

The test requirements concerning fractures or cracks, maximum instantaneous deflection and the zone of clearance were/were not ⁽¹⁾ satisfactorily fulfilled.

7.2. Deflection measured after the tests

Permanent deflection:

rear: left-hand: mm

right-hand: mm

front: left-hand: mm

right-hand: mm

side sideways:

front: mm

rear: mm

top downwards:

front: mm

rear: mm

Difference between maximum momentary and residual deflection during sideways impact test: mm

8. Report number:

9. Report date:

10. Signature:

⁽¹⁾ Delete where inapplicable.

ANNEX VI

MARKS

The EEC component type-approval mark shall consist of:

- a rectangle surrounding the lower-case letter 'e' followed by the distinguishing letter(s) or number of the Member State which has granted the component type-approval:
 - 1 for Germany,
 - 2 for France,
 - 3 for Italy,
 - 4 for the Netherlands,
 - 6 for Belgium,
 - 9 for Spain,
 - 11 for the United Kingdom,
 - 13 for Luxembourg,
 - 18 for Denmark,
 - IRL for Ireland,
 - EL for Greece,
 - P for Portugal,
- the EEC component type-approval number which corresponds to the number of the EEC component type-approval certificate issued with regard to the strength of the type of protection structure and its attachment to the tractor placed under and in the vicinity of the rectangle,
- the letters V or SV, depending on whether a dynamic (V) or static (SV) test was conducted, followed by the number 1, indicating that this is a protection structure within the meaning of this Directive.

Example of EEC component type-approval mark

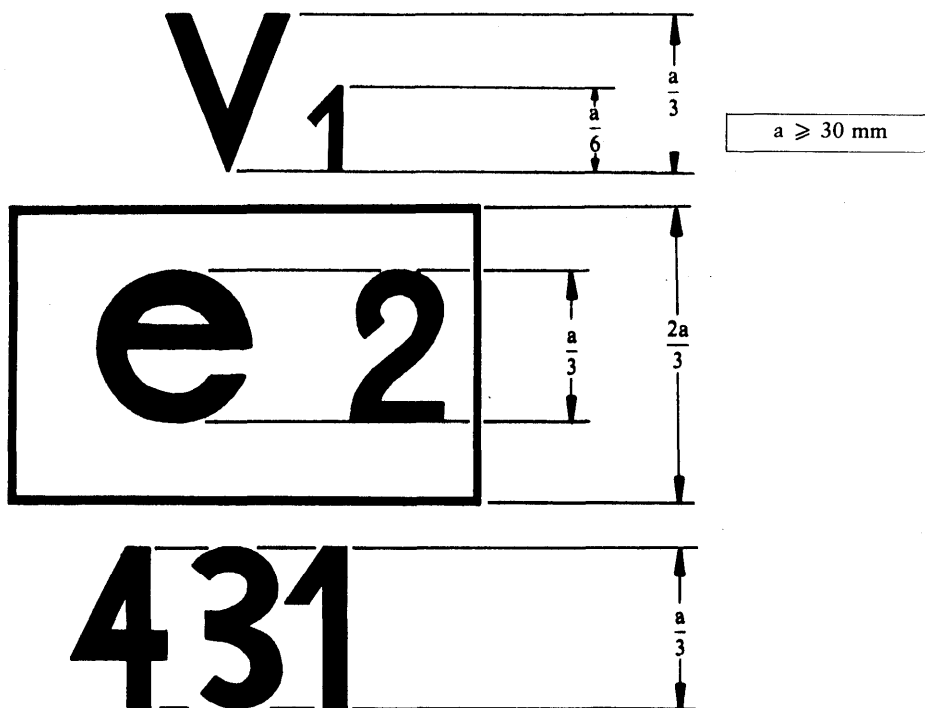

The protection structure bearing the EEC component type-approval mark shown above is a structure of the rear-mounted rollbar, frame or cab type which has been subjected to a dynamic test, is intended for a narrow-track tractor (V1) and for which EEC component type-approval was granted in France (e2) under the number 431.

ANNEX VII

MODEL EEC COMPONENT TYPE-APPROVAL CERTIFICATE

Name of competent authority

Notification concerning the granting, refusal, withdrawal or extension of EEC component type-approval with regard to the strength of a protection structure (rear-mounted rollbar, frame or cab) and to the strength of its attachment to the tractor

EEC component type-approval No:
 extension ⁽¹⁾

1. Trade name or mark and type of protection structure:
2. Name and address of manufacturer of protection structure:
3. If applicable, name and address of authorized representative of manufacturer of protection structure:
4. Trade mark or name, type and commercial description of tractor for which protection structure is intended:
5. Extension of EEC component type-approval for tractors of the following type(s) and, where appropriate, commercial descriptions:
- 5.1. The mass of the unballasted tractor, as defined in 1.4 of Annex II, exceeds/does not exceed ⁽²⁾ the reference mass used for the test by more than 5 %.
- 5.2. The method of attachment and points of attachment are/are not ⁽²⁾ identical.
- 5.3. All the components likely to serve as supports for the protection structure are/are not ⁽²⁾ identical.
6. Submitted for EEC component type-approval on:
7. Test station:
8. Date and number of the report of the test station:
9. Date of granting/refusal/withdrawal of EEC component type-approval ⁽²⁾:
10. Date of granting/refusal/withdrawal of the extension of EEC component type-approval ⁽²⁾:
11. Place:
12. Date:
13. The following documents, bearing the component type-approval number shown above, are annexed to this certificate (e.g. report of the test station). These documents must be sent to the competent authorities of the other Member States if they so request
14. Remarks, if any:
15. Signature:

⁽¹⁾ If applicable, state whether this is the first, etc. extension of the original EEC component type-approval.

⁽²⁾ Delete where inapplicable.

ANNEX VIII

CONDITIONS FOR EEC TYPE-APPROVAL

1. The application for EEC type-approval of a tractor with regard to the strength of a protection structure and the strength of its attachment to the tractor shall be submitted by the tractor manufacturer or by his authorized representative.
2. A tractor representative of the tractor type to be approved, on which a protection structure and its attachment, duly approved, are mounted, shall be submitted to the technical services responsible for conducting the type-approval tests.
3. The technical service responsible for conducting the type-approval tests shall check whether the approved type of protection structure is intended to be mounted on the type of tractor for which the type-approval is requested. In particular, it shall ascertain whether the attachment of the component type-approval was granted.
4. The holder of the EEC type-approval may ask for its extension to other types of protection structures.
5. The competent authorities shall grant such extension on the following conditions:
 - 5.1. The new type of protection structure and its tractor attachment must have received EEC component type-approval.
 - 5.2. The new type of protection structure must be designed to be mounted on the type of tractor for which the extension of the EEC type-approval is requested.
 - 5.3. The attachment of the protection structure to the tractor must correspond to that which was tested when EEC component type-approval was granted.
6. A certificate, of which a model is shown in Annex IX, shall be annexed to the EEC type-approval certificate for each type-approval or type-approval extension which has been granted or refused.
7. If the application for EEC type-approval for a type of tractor is introduced at the same time as the request for EEC component type-approval for a type of protection structure intended to be mounted on the type of tractor for which type-approval is requested, the checks laid down in 2 and 3 are not applicable.

ANNEX IX

MODEL

Name of competent authority

**ANNEX TO THE EEC TYPE-APPROVAL CERTIFICATE FOR A TRACTOR TYPE WITH REGARD TO
THE STRENGTH OF PROTECTION STRUCTURES (REAR-MOUNTED ROLLBAR, FRAME OR CAB)
AND THE STRENGTH OF THEIR ATTACHMENT TO THE TRACTOR**

(Articles 4 (2) and 10 of Council Directive 74/150/EEC of 4 March 1974 on the approximation of the laws of the Member States relating to the type-approval of wheeled agricultural or forestry tractors)

EEC type-approval No:
.....extension (1)

1. Trade name or mark of tractor:
2. Tractor type and commercial description:
3. Name and address of tractor manufacturer:
.....
4. If applicable, name and address of manufacturer's authorized representative:
.....
5. Trade name or mark and type of protection structure:
.....
6. Extension of EEC-approval for the following type(s) of protection structure:
.....
7. Tractor submitted for EEC type-approval on:
8. Technical service responsible for EEC type-approval conformity control:
.....
9. Date of report issued by that service:
10. Number of report issued by that service:
11. EEC type-approval with regard to the strength of the protection structures and the strength of their attachment to the tractor has been granted/refused (2).
12. The extension of EEC type-approval with regard to the strength of the protection structures and the strength of their attachment to the tractor has been granted/refused (2).
13. Place:
14. Date:
15. Signature:

(1) If applicable, state whether this is the first, etc. extension of the original EEC type-approval.

(2) Delete where inapplicable.