

## II

(Non-legislative acts)

## ACTS ADOPTED BY BODIES CREATED BY INTERNATIONAL AGREEMENTS

Only the original UN/ECE texts have legal effect under international public law. The status and date of entry into force of this Regulation should be checked in the latest version of the UN/ECE status document TRANS/WP.29/343, available at:  
<http://www.unece.org/trans/main/wp29/wp29wgs/wp29gen/wp29fdocstts.html>

### **Regulation No 25 of the Economic Commission for Europe of the United Nations (UN/ECE) — Uniform provisions concerning the approval of head restraints (headrests), whether or not incorporated in vehicle seats**

Incorporating all valid text up to:

04 series of amendments — Date of entry into force: 15 January 1997

Corrigendum 2 to Revision 1 of the Regulation — Date of entry into force: 12 November 2008

#### CONTENTS

##### REGULATION

1. Scope
2. Definitions
3. Application for approval
4. Markings
5. Approval
6. General specifications
7. Tests
8. Conformity of production
9. Penalties for non-conformity of production
10. Modification and extension of approval of a type of head restraint
11. Instructions
12. Production definitely discontinued
13. Transitional provisions
14. Names and addresses of technical services responsible for conducting approval tests and of administrative departments

##### ANNEXES

- Annex 1 — Communication concerning the approval or refusal or extension or withdrawal of approval or production definitely discontinued of a type of head restraint, whether or not incorporated in a seat pursuant to Regulation No 25
- Annex 2 — Arrangements of approval marks
- Annex 3 — Procedure for determining the 'H' point and the actual torso angle for seating positions in motor vehicles

- Annex 4 — Determination of height and width of head restraint
- Annex 5 — Details of lines drawn and measurements taken during tests
- Annex 6 — Test procedure for checking energy dissipation
- Annex 7 — Determination of dimension 'A' of head restraint gaps

## 1. SCOPE

1.1. This Regulation applies to head-restraint devices conforming to one of the types defined in paragraph 2.2 below <sup>(1)</sup>.

1.1.1. It does not apply to head-restraint devices which may be fitted to folding seats or seats facing towards the side or towards the rear.

1.1.2. It applies to seat backs themselves, when they are so designed as to serve also as head restraints as defined in paragraph 2.2 below.

## 2. DEFINITIONS

For the purposes of this Regulation,

2.1. 'Vehicle type' means a category of power-driven vehicles which do not differ in such essential respects as:

2.1.1. the lines and internal dimensions of the bodywork constituting the passenger compartment,

2.1.2. the types and dimensions of the seats,

2.1.3. type and dimensions of head-restraint attachment and of the relevant parts of the vehicle structure in the case of head restraint directly anchored to the vehicle structure;

2.2. 'Head restraint' means a device whose function is to limit the rearward displacement of an adult occupant's head in relation to his torso in order to reduce the danger of injury to the cervical vertebrae of that occupant in the event of an accident;

2.2.1. 'Integrated head restraint' means a head restraint constituted by the upper part of the seat back. Head restraints corresponding to the definitions in paragraphs 2.2.2 and 2.2.3 below, but which cannot be detached from the seat or the vehicle structure except by the use of tools or following the partial or total removal of the seat furnishings, correspond to this definition;

2.2.2. 'Removable head restraint' means a head restraint constituted by a component separable from the seat, designed for insertion and positive retention in the seat back structure;

2.2.3. 'Separate head restraint' means a head restraint constituted by a separate component of the seat, designed for insertion and/or positive retention in the structure of the vehicle;

2.3. 'Type of seat' means a category of seats which do not differ in their dimensions, in their framework or in their padding, although they may differ in finish and colour;

2.4. 'Type of head restraint' means a category of head restraints which do not differ in their dimensions, in their framework or in their padding, although they may differ in finish, in colour and in covering;

<sup>(1)</sup> The head restraints of category M<sub>1</sub> vehicles which conform to the provisions of Regulation No 17 are not required to conform to the provisions of this Regulation.

- 2.5. 'Reference point' of the seat ('H point') (see Annex 3 to this Regulation) means the trace, in a vertical plane longitudinal in relation to the seat, of the theoretical axis of rotation between the leg and the torso of a human body represented by a manikin;
- 2.6. 'Reference line' means a straight line which, either on a test manikin having the weight and dimensions of a fiftieth percentile adult male or on a test manikin having identical characteristics, passes through the joint of the leg with the pelvis and the joint of the neck with the thorax. On the manikin reproduced in Annex 3 to this Regulation, for determining the H point of the seat, the reference line is that shown in figure 1 in the appendix to that Annex;
- 2.7. 'Head line' means a straight line passing through the centre of gravity of the head and through the joint of the neck with the thorax. When the head is at rest the head line is situated in the extension of the reference line;
- 2.8. 'Folding seat' means an auxiliary seat intended for occasional use and normally folded;
- 2.9. 'Adjustment system' means the device by which the seat or its parts can be adjusted to a position suited to the morphology of the seated occupant.

This device may, in particular, permit:

- 2.9.1. longitudinal displacement,
- 2.9.2. vertical displacement,
- 2.9.3. angular displacement;
- 2.10. 'Displacement system' means a device by which the seat or one of its parts can be displaced or rotated, without a fixed intermediate position, to permit easy access to the space behind the seat concerned.
3. APPLICATION FOR APPROVAL
- 3.1. The application for approval shall be submitted by the holder of the trade name or mark of the seat or the head restraint or by his duly accredited representative.
- 3.2. It shall be accompanied by the undermentioned documents in triplicate:
- 3.2.1. a detailed description of the head restraint, specifying in particular the nature of the padding material or materials and, where applicable, the position and specifications of the braces and anchorage pieces for the type or types of seats for which approval of the head restraint is sought;
- 3.2.2. In the case of a 'removable' head restraint (see the definition in paragraph 2.2.2):
- 3.2.2.1. a detailed description of the type or types of seats for which approval of the head restraint is sought,
- 3.2.2.2. particulars identifying the type or types of vehicle on which the seats referred to in paragraph 3.2.2.1 above are intended to be fitted;
- 3.2.3. In the case of a 'separate' head restraint (see the definition in paragraph 2.2.3):
- 3.2.3.1. a detailed description of the structural zone to which the head restraint is intended to be fixed,
- 3.2.3.2. particulars identifying the type of vehicle to which the head restraints are intended to be fitted,

- 3.2.3.3. dimensional drawings of the characteristic parts of the structure and the head restraint, the drawings must show the position intended for the approval number in relation to the circle of the approval mark;
- 3.2.4. dimensioned drawings of the characteristic parts of the seat and the head restraint. The drawings must show the position intended for the approval number in relation to the circle of the approval mark.
- 3.3. The following shall be submitted to the technical service responsible for conducting the approval tests:
  - 3.3.1. If the head restraint is of the 'integral' type (see the definition in paragraph 2.2.1), four complete seats.
  - 3.3.2. If the head restraint is of the 'removable' type (see the definition in paragraph 2.2.2):
    - 3.3.2.1. two seats of each of the types to which the head restraint is to be fitted;
    - 3.3.2.2.  $4 + 2N$  head restraints,  $N$  being the number of types of seat to which the head restraint is to be fitted.
    - 3.3.3. If the head restraint is of the 'separate' type (see the definition in paragraph 2.2.3), three head restraints and the relevant part of the vehicle structure, or a complete vehicle.
  - 3.4. The technical service responsible for conducting the approval tests may request:
    - 3.4.1. the delivery to that service of specific parts, or of specific samples of the materials used, and/or
    - 3.4.2. the production to that service of vehicles of the type or types referred to in paragraph 3.2.2.2 above.
4. MARKINGS
  - 4.1. The devices submitted for approval shall:
    - 4.1.1. be clearly and indelibly marked with the trade name or mark of the applicant for approval;
    - 4.1.2. provide, at a site shown in the drawings referred to in paragraphs 3.2.3.3 or 3.2.4 above, adequate space for the approval mark.
  - 4.2. Where the head restraint is of the 'integral' or 'removable' type (see definitions in paragraphs 2.2.1 and 2.2.2), the markings referred to in paragraphs 4.1.1 and 4.1.2 above may be reproduced on labels situated at a site shown in the drawings referred to in paragraph 3.2.4 above.
5. APPROVAL
  - 5.1. If the type of head restraint submitted for approval pursuant to this Regulation meets the requirements of paragraphs 6 and 7 below, approval of that type of head restraint shall be granted.
  - 5.2. An approval number shall be assigned to each type approved. Its first two digits (at present 03 corresponding to the 03 series of amendments which entered into force on 20 November 1989) shall indicate the series of amendments incorporating the most recent major technical amendments made to the Regulation at the time of issue of the approval. The same Contracting Party shall not assign this number to another type of head restraint.
  - 5.3. Notice of approval or of extension or of refusal of approval of a type of head restraint pursuant to this Regulation shall be communicated to the Parties to the 1958 Agreement applying this Regulation, by means of a form conforming to the model in Annex I to this Regulation.

- 5.4. There shall be affixed to every head restraint defined in paragraphs 2.2.1, 2.2.2 and 2.2.3 approved under this Regulation, whether incorporated in a seat or not, an international approval mark consisting of:
- 5.4.1. a circle surrounding the letter 'E' followed by the distinguishing number of the country which has granted approval <sup>(1)</sup>;
- 5.4.2. the approval number; and
- 5.4.3. in the case of a head restraint incorporated in the seat back, in front of the approval number, the number of this Regulation, the letter 'R' and a dash.
- 5.5. The approval mark shall be affixed in the space referred to in paragraph 4.1.2 above.
- 5.6. The approval mark shall be clearly legible and be indelible.
- 5.7. Annex 2 to this Regulation gives examples of the arrangement of the approval marks.
6. GENERAL SPECIFICATIONS
- 6.1. The presence of the head restraint shall not be an additional cause of danger to occupants of the vehicle. In particular it shall not in any position of use exhibit any dangerous roughness or sharp edge liable to increase the risk or seriousness of injury to the occupants. Parts of the head restraint which are situated in the impact zone defined below shall be capable of dissipating energy in the manner specified in Annex 6 to this Regulation.
- 6.1.1. The impact zone is bounded laterally by two vertical longitudinal planes, one on each side of and each 70 mm distant from the plane of symmetry of the seat considered.
- 6.1.2. The impact zone is limited in height to the part of the head restraint situated above the plane perpendicular to the reference line R and 635 mm distant from the H point.
- 6.1.3. By derogation from the above provisions, the requirements concerning energy absorption shall not apply to the rear faces of head restraints for seats behind which there are no other seats.
- 6.2. Parts of the front and rear faces of the head restraint, excluding parts of the rear faces of head restraints designed to be installed in seats behind which no other seating positions are provided, which are situated outward of the longitudinal vertical planes defined above shall be so padded as to prevent any direct contact of the head with the components of the structure, which shall, in those areas which can be contacted by a sphere of 165 mm diameter, have a radius of curvature of not less than 5 mm.

Alternatively, these components may be considered satisfactory if they pass the energy-absorption test described in Annex 6 to this Regulation. If the above-mentioned parts of the head restraints and their supports are covered with material softer than 50 Shore (A) hardness, the requirements of this paragraph, with the exception of those relating to energy absorption as defined in Annex 6 to this Regulation, shall apply only to the rigid parts.

<sup>(1)</sup> 1 for Germany, 2 for France, 3 for Italy, 4 for the Netherlands, 5 for Sweden, 6 for Belgium, 7 for Hungary, 8 for the Czech Republic, 9 for Spain, 10 for Yugoslavia, 11 for the United Kingdom, 12 for Austria, 13 for Luxembourg, 14 for Switzerland, 15 (vacant), 16 for Norway, 17 for Finland, 18 for Denmark, 19 for Romania, 20 for Poland, 21 for Portugal, 22 for the Russian Federation, 23 for Greece, 24 (vacant), 25 (vacant), 26 for Slovenia and 27 for Slovakia. Subsequent numbers shall be assigned to other countries in the chronological order in which they ratify or accede to the Agreement concerning the Adoption of Uniform Conditions of Approval and Reciprocal Recognition of Approval for Motor Vehicle Equipment and Parts and the numbers thus assigned shall be communicated by the Secretary-General of the United Nations to the Contracting Parties to the Agreement.

- 6.3. The head restraint shall be anchored to the seat or, where appropriate, to the vehicle structure, in such a way that no rigid and dangerous part projects from the padding of the head restraint, from the anchorage or from the seat back as a result of the pressure exerted by the head during the test.
- 6.4. The height of the head restraint, measured in accordance with the requirements of paragraph 7.2 below, shall conform to the following specifications:
  - 6.4.1. The height of head restraints shall be measured as described in paragraph 7.2 below.
  - 6.4.2. For head restraints not adjustable for height, the height shall be not less than 800 mm in the case of front seats and 750 mm in the case of other seats.
  - 6.4.3. For head restraints adjustable for height:
    - 6.4.3.1. the height shall be not less than 800 mm in the case of front seats and 750 mm in the case of other seats; this value shall be obtained in a position between the highest and lowest positions to which adjustment is possible;
    - 6.4.3.2. there shall be no 'use position' resulting in a height of less than 750 mm;
    - 6.4.3.3. in the case of seats other than the front seats the head restraints may be such that they can be displaced to a position resulting in a height of less than 750 mm, provided that such position is clearly recognisable to the occupant as not being included for the use of the head restraint;
    - 6.4.3.4. in the case of front seats head restraints may be such that they can be automatically displaced when the seat is not occupied, to a position resulting in a height of less than 750 mm, provided that they automatically return to the position of use when the seat is occupied.
  - 6.4.4. The dimensions mentioned in paragraphs 6.4.2 and 6.4.3.1 above may be less than 800 mm in the case of front seats and 750 mm in the case of other seats to leave adequate clearance between the head restraint and the interior surface of the roof, the windows or any part of the vehicle structure; however, the clearance shall not exceed 25 mm. In the case of seats fitted with displacement and/or adjustment systems, this shall apply to all seat positions. Furthermore, by derogation to paragraph 6.4.3.2 above, there shall not be any 'use position' resulting in a height lower than 700 mm.
  - 6.4.5. By derogation to the height requirements mentioned in paragraphs 6.4.2 and 6.4.3.1 above, the height of any head restraint designed to be provided in rear centre seats or seating positions shall be not less than 700 mm.
- 6.5. The height of the device on which the head rests, measured as prescribed in paragraph 7.2, shall in the case of a head restraint adjustable for height be not less than 100 mm.
- 6.6. There shall be no gap of more than 60 mm between the seat back and the head restraint in the case of a device not adjustable for height.
  - 6.6.1. If the head restraint is adjustable for height it shall, in its lowest position, be not more than 25 mm from the top of the seat back.

- 6.6.2. In the case of a head restraint not adjustable for height, the area to be considered is:
- 6.6.2.1. above a plane perpendicular to the reference line at 540 mm from the R point and
- 6.6.2.2. between two vertical longitudinal planes passing at 85 mm on either side of the reference line.

In this area, one or more gaps, which regardless of its shape can show a distance 'a' measured as described in paragraph 7.5 of more than 60 mm, are permitted provided that after the additional test under paragraph 7.4.3.4, the requirements of paragraph 7.4.3.6 are still met.

- 6.6.3. In the case of head restraints adjustable for height, one or more gaps, which regardless of its shape can show a distance 'a' measured as described in paragraph 7.5 of more than 60 mm, are permitted on the part of the device serving as the head restraint provided that, after the additional test under paragraph 7.4.3.4, the requirements of paragraph 7.4.3.6 are still met.
- 6.7. The width of the head restraint shall be such as to provide suitable support for the head of a person normally seated. In the plane of measurement of width defined in paragraph 7.3 below, the head restraint shall cover an area extending not less than 85 mm to each side of the plane of symmetry of the seat for which the head restraint is intended, that distance being measured as prescribed in paragraph 7.3.
- 6.8. The head restraint and its anchorage shall be such that the maximum backward displacement of the head permitted by the head restraint and measured in conformity with the static procedure prescribed in paragraph 7.4 below is less than 102 mm.
- 6.9. The head restraint and its anchorage shall be strong enough to bear without failure the load prescribed in paragraph 7.4.3.7 below.
- 6.10. If the head restraint is adjustable, it must not be possible to exceed the maximum prescribed height for use without voluntary action by the user in addition to adjusting operation.

## 7. TESTS

- 7.1. Determination of the reference point (H point) of the seat in which the head restraint is incorporated
- This point shall be determined in conformity with the requirements of Annex 3 to this Regulation.
- 7.2. Determination of the height of the head restraint
- 7.2.1. All lines shall be drawn in the plane of symmetry of the seat considered, the intersection of which plane with the seat determines the contour of the head restraint and of the seat back (see Annex 4, figure 1, to this Regulation).
- 7.2.2. The manikin corresponding to a fiftieth percentile adult male or the manikin shown in Annex 3 to this Regulation shall be placed in a normal position on the seat. The seat back, if inclinable, shall be locked in a position corresponding to a rearward inclination of the reference line of the manikin's torso of as nearly as possible 25° from the vertical.
- 7.2.3. The projection of the reference line of the manikin shown in Annex 3 shall in the case of the seat considered be drawn in the plane specified in paragraph 7.2.1. The tangent S to the top of the head restraint shall be drawn perpendicular to the reference line.
- 7.2.4. The distance h from the H point to the tangent S is the height to be taken into consideration in implementing the requirement of paragraph 6.4.

- 7.3. Determination of the width of the head restraint (see Annex 4, figure 2, to this Regulation).
- 7.3.1. The plane  $S_1$  perpendicular to the reference line and situated 65 mm below the tangent S defined in paragraph 7.2.3 defines a section in the head restraint bounded by the outline C. The direction of the straight lines tangential to C representing the intersection of the vertical planes (P and P'), parallel to the plane of symmetry of the seat considered, with the plane  $S_1$  shall be traced in the plane  $S_1$ .
- 7.3.2. The width of the head restraint to be taken into consideration in implementing the requirement of paragraph 6.7 is the distance L separating the traces of planes P and P' in plane  $S_1$ .
- 7.3.3. The width of the head restraint shall if necessary also be determined 635 mm above the reference point of the seat, this distance being measured along the reference line.
- 7.4. Determination of the effectiveness of the device
- 7.4.1. The effectiveness of the head restraint shall be checked by the static test described below.
- 7.4.2. Preparation for the test
- 7.4.2.1. If the head restraint is adjustable it shall be set in the highest position.
- 7.4.2.2. In the case of a bench seat, where part or all of the supporting frame (including that of the head restraints) is common to more than one seating position, the test shall be conducted simultaneously for all those seating positions.
- 7.4.2.3. If the seat or the seat-back is adjustable relative to a head restraint anchored to the vehicle structure, it shall be placed in the most unfavourable position as considered by the technical service.
- 7.4.3. Testing
- 7.4.3.1. All lines shall be drawn in the vertical plane of symmetry of the seat considered (see Annex 5 to this Regulation).
- 7.4.3.2. A projection of the reference line R shall be drawn in the plane referred to in paragraph 7.4.3.1.
- 7.4.3.3. The displaced reference line  $R_1$  shall be determined by applying to the part simulating the back in the manikin referred to in Annex 3 to this Regulation an initial force producing a rearward moment of 37,3 daNm about the H point.
- 7.4.3.4. By means of a spherical head 165 mm in diameter an initial force producing a moment of 37,3 daNm about the H point shall be applied at right angles to the displaced reference line  $R_1$  at a distance of 65 mm below the top of the head restraint the reference line being retained in its displaced position  $R_1$  as determined in accordance with the requirements of paragraph 7.4.3.3 above.
- 7.4.3.4.1. If the presence of gaps prevents the application of the force prescribed above at 65 mm from the top of the head restraint, the distance may be reduced so that the axis of the force passes through the centre line of the frame element nearest to the gap.
- 7.4.3.4.2. In the case described in paragraphs 6.6.2 and 6.6.3 above, the test shall be repeated by applying to each gap, using a sphere of 165 mm in diameter, a force:

passing through the centre of gravity of the smallest of the sections of the gap, along transversal planes parallel to the reference line, and reproducing a moment of 37,3 daNm about the 'R' point.



- 7.4.3.5. The tangent Y to the spherical head, parallel to the displaced reference line  $R_1$ , shall be determined.
- 7.4.3.6. The distance X between the tangent Y and the displaced reference line  $R_1$  shall be measured. The requirement of paragraph 6.8 shall be considered to be met if the distance X is less than 102 mm.
- 7.4.3.7. In cases where the force prescribed in paragraph 7.4.3.4 is applied at a distance of 65 mm or less below the top of the head restraint, and only in such cases, it shall be increased to 89 daN unless breakage of the seat or its back occurs earlier.
- 7.5. Determination of distance 'a' of head restraint gaps (see Annex 7 to this Regulation)
- 7.5.1. The distance 'a' shall be determined for each gap and in relation to the front face of the head restraint, by means of a sphere having a diameter of 165 mm;
- 7.5.2. The sphere shall be put into contact with the gap in a point of the gap area which allows the maximum sphere intrusion considering no load to be applied;
- 7.5.3. The distance between the two points of contact of the sphere with the gap will constitute the distance 'a' to be considered for the evaluation of the provisions under paragraph 6.6.2 and 6.6.3.
8. CONFORMITY OF PRODUCTION
- 8.1. Every head restraint or seat bearing an approval mark in conformity with Annex 2 shall conform to the type of head restraint approved and comply with the conditions prescribed in paragraphs 6 and 7 above.
- 8.2. In order to verify conformity as aforesaid, a sufficient number of random checks shall be performed on serially-produced head restraints.
- 8.3. Head restraints offered or to be offered for sale shall be used for the tests.
- 8.4. Head restraints selected for verification of conformity with an approved type shall undergo the test described in paragraph 7 of this Regulation.
9. PENALTIES FOR NON-CONFORMITY OF PRODUCTION
- 9.1. Approved head restraints
- The approval granted in respect of a type of head restraint pursuant to this Regulation may be withdrawn if head restraints bearing the particulars referred to in paragraph 5.4 above fail to pass the random checks or do not conform to the type approved.
- 9.2. If a Contracting Party to the Agreement applying this Regulation withdraws an approval it has previously granted, it shall forthwith so notify the other Contracting Parties applying this Regulation, by means of a communication form conforming to the model in Annex 1 to this Regulation.
10. MODIFICATION AND EXTENSION OF APPROVAL OF A TYPE OF HEAD RESTRAINT
- 10.1. Every modification of the type of head restraint shall be notified to the administrative department which approved the type of head restraint. The department may then either:
- 10.1.1. Consider that the modifications made are unlikely to have an appreciable adverse effect and that in any case the head restraint still complies with the requirements; or
- 10.1.2. Require a further test report from the technical service responsible for conducting the tests.

- 10.2. Confirmation or refusal of approval, specifying the alterations shall be communicated by the procedure specified in paragraph 5.3 above to the Parties to the Agreement applying this Regulation.
- 10.3. The competent authority issuing the extension of approval shall assign a series number for such an extension and inform thereof the other Parties to the 1958 Agreement applying this Regulation by means of a communication form conforming to the model in Annex 1 to this Regulation.
11. INSTRUCTIONS
- The manufacturer shall supply, with each model conforming to a type of head restraint approved, particulars of the types and characteristics of the seats for which the head restraint is approved. When the head restraint is adjustable, the adjusting and/or release operations must be clearly stated in this notice.
12. PRODUCTION DEFINITELY DISCONTINUED
- If the holder of the approval completely ceases to manufacture a head restraint approved in accordance with this Regulation, he shall so inform the authority which granted the approval. Upon receiving the relevant communication that authority shall inform thereof the other Parties to the 1958 Agreement applying this Regulation by means of a communication form conforming to the model in Annex 1 to this Regulation.
13. TRANSITIONAL PROVISIONS
- 13.1. As from the official date of entry into force of the 04 series of amendments, no Contracting Party applying this Regulation shall refuse to grant ECE approvals under this Regulation as amended by the 04 series of amendments.
- 13.2. As from 24 months after the date of entry into force of the 04 series of amendments, Contracting Parties applying this Regulation shall grant ECE approval only if the vehicle type to be approved complies with the requirements of this Regulation as amended by the 04 series of amendments.
- 13.3. As from 48 months after the date of entry into force of the 04 series of amendments, existing approvals to this Regulation shall cease to be valid, except in the case of vehicle types which comply with the requirements of this Regulation as amended by the 04 series of amendments.
14. NAMES AND ADDRESSES OF TECHNICAL SERVICES RESPONSIBLE FOR CONDUCTING APPROVAL TESTS AND OF ADMINISTRATIVE DEPARTMENTS
- The Parties to the 1958 Agreement applying this Regulation shall communicate to the Secretariat of the United Nations the names and addresses of the technical services responsible for conducting approval tests and of the administrative departments which grant approval and to which forms certifying approval or extension or refusal or withdrawal of approval, issued in other countries, are to be sent.
-

ANNEX 1

COMMUNICATION

(maximum format: A4 (210 × 297 mm))

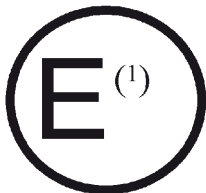

issued by: Name of administration:

.....  
.....  
.....

- concerning <sup>(2)</sup>: APPROVAL GRANTED
- APPROVAL EXTENDED
- APPROVAL REFUSED
- APPROVAL WITHDRAWN
- PRODUCTION DEFINITELY DISCONTINUED

of a type of head restraint, whether or not incorporated in a seat pursuant to Regulation No 25

Approval No ..... Extension No .....

- 1. Trade name or mark .....
- 2. Manufacturer's name .....
- 3. If applicable, name of manufacturer's representative .....
- 4. Address .....
- 5. Submitted for approval on .....
- 6. Technical service conducting tests .....
- 7. Brief description of the head restraint <sup>(3)</sup> .....
- 8. Type and characteristics of the seats for which the head restraint is intended or in which it is incorporated .....
- 9. Types of vehicles for which the seats for which the head restraint is designed are intended .....
- 10. Date of report issued by the technical service .....
- 11. Number of report issued by the technical service .....
- 12. Approval granted/refused/extended/withdrawn <sup>(2)</sup> .....
- 13. Place .....
- 14. Date .....
- 15. Signature .....
- 16. The list of documents filed with the administration service which has granted approval and available on request is annexed to this communication.

---

<sup>(1)</sup> Distinguishing number of the country which has granted/extended/refused/withdrawn approval (see approval provisions in the Regulation).  
<sup>(2)</sup> Strike out what does not apply.  
<sup>(3)</sup> In the case of 'integrated' or 'removable' head restraints (see the definitions in paragraphs 2.2.1 and 2.2.2 of this Regulation), this item need not be completed if all the necessary characteristics and particulars are entered under item 8.

## ANNEX 2

## ARRANGEMENTS OF APPROVAL MARKS (\*)

Approval mark for an 'integrated' or 'removable' type head restraint (see the definitions in paragraphs 2.2.1 and 2.2.2 of this Regulation).

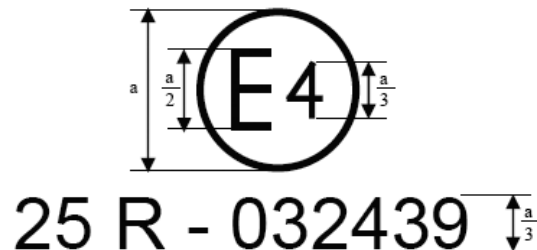

The above approval mark affixed to one or more 'integrated' or 'removable' type head restraints shows that, pursuant to Regulation No 25, the type of head restraint has been approved in the Netherlands (E4) under approval number 032439. The first two digits of the approval number indicate that the approval was granted in accordance with the requirements of Regulation No 25 as amended by the 03 series of amendments.

Approval mark for a 'separate' type head restraint (see the definition in paragraph 2.2.3 of this Regulation).

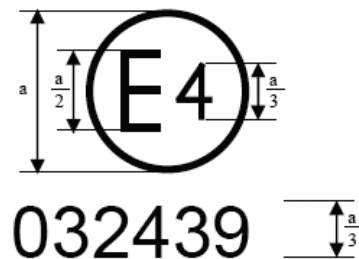

The above approval mark affixed to a head restraint shows that the head restraint in question has been approved and that it is a 'separate' head restraint, approved in the Netherlands (E4), under approval number 032439. The first two digits of the approval number indicate that the approval was granted in accordance with the requirements of Regulation No 25, as amended by the 03 series of amendments.

(\*) The approval number must be placed close to the circle and either above or below the 'E', or to the left or right of that letter.

## ANNEX 3

**Procedure for determining the 'H' point and the actual torso angle for seating positions in motor vehicles**

## 1. PURPOSE

The procedure described in this Annex is used to establish the 'H' point location and the actual torso angle for one or several seating positions in a motor vehicle and to verify the relationship of measured data to design specifications given by the vehicle manufacturer <sup>(1)</sup>.

## 2. DEFINITIONS

For the purposes of this Annex:

2.1. 'Reference data' means one or several of the following characteristics of a seating position:

2.1.1. the 'H' point and the 'R' point and their relationship;

2.1.2. the actual torso angle and the design torso angle and their relationship.

2.2. 'Three-dimensional "H" point machine' (3-D H machine) means the device used for the determination of 'H' points and actual torso angles. This device is described in Appendix 1 to this Annex.

2.3. 'H' point means the pivot centre of the torso and thigh of the 3-D H machine installed in the vehicle seat in accordance with paragraph 4 below. The 'H' point is located in the centre of the centreline of the device which is between the 'H' point sight buttons on either side of the 3-D H machine. The 'H' point corresponds theoretically to the 'R' point (for tolerances see paragraph 3.2.2 below). Once determined in accordance with the procedure described in paragraph 4, the 'H' point is considered fixed in relation to the seat-cushion structure and to move with it when the seat is adjusted.

2.4. 'R' point or 'seating reference point' means a design point defined by a vehicle manufacturer for each seating position and established with respect to the three-dimensional reference system.

2.5. 'Torso-line' means the centreline of the probe of the 3-D H machine with the probe in the fully rearward position.

2.6. 'Actual torso angle' means the angle measured between a vertical line through the 'H' point and the torso line using the back angle quadrant on the 3-D H machine. The actual torso angle corresponds theoretically to the design torso angle (for tolerances see paragraph 3.2.2 below).

2.7. 'Design torso angle' means the angle measured between a vertical line through the 'R' point and the torso line in a position which corresponds to the design position of the seat-back established by the vehicle manufacturer.

2.8. 'Centreplane of occupant' (C/LO) means the median plane of the 3-D H machine positioned in each designated seating position; it is represented by the coordinate of the 'H' point on the 'Y' axis. For individual seats, the centreplane of the seat coincides with the centreplane of the occupant. For other seats, the centreplane of the occupant is specified by the manufacturer;

2.9. 'Three-dimensional reference system' means a system as described in Appendix 2 to this Annex;

2.10. 'Fiducial marks' are physical points (holes, surfaces, marks or indentations) on the vehicle body as defined by the manufacturer;

2.11. 'Vehicle measuring attitude' means the position of the vehicle as defined by the coordinates of fiducial marks in the three-dimensional reference system.

<sup>(1)</sup> In any seating position other than front seats where the 'H' point cannot be determined using the 'Three-dimensional "H" point machine' or procedures, the 'R' point indicated by the manufacturer may be taken as a reference at the discretion of the competent authority.

### 3. REQUIREMENTS

#### 3.1. Data presentation

For each seating position where reference data are required in order to demonstrate compliance with the provisions of the present Regulation, all or an appropriate selection of the following data shall be presented in the form indicated in appendix 3 to this Annex:

- 3.1.1. the coordinates of the 'R' point relative to the three-dimensional reference system;
  - 3.1.2. the design torso angle;
  - 3.1.3. all indications necessary to adjust the seat (if it is adjustable) to the measuring position set out in paragraph 4.3 below.
- #### 3.2. Relationship between measured data and design specifications
- 3.2.1. The coordinates of the 'H' point and the value of the actual torso angle obtained by the procedure set out in paragraph 4 below shall be compared, respectively, with the coordinates of the 'R' point and the value of the design torso angle indicated by the vehicle manufacturer.
  - 3.2.2. The relative positions of the 'R' point and the 'H' point and the relationship between the design torso angle and the actual torso angle shall be considered satisfactory for the seating position in question if the 'H' point, as defined by its coordinates, lies within a square of 50 mm side length with horizontal and vertical sides whose diagonals intersect at the 'R' point, and if the actual torso angle is within 5 degree of the design of the torso angle.
  - 3.2.3. If these conditions are met, the 'R' point and the design torso angle, shall be used to demonstrate compliance with the provisions of this Regulation.
  - 3.2.4. If the 'H' point or the actual torso angle does not satisfy the requirements of paragraph 3.2.2 above, the 'H' point and the actual torso angle shall be determined twice more (three times in all). If the results of two of these three operations satisfy the requirements, the conditions of paragraph 3.2.3 above shall apply.
  - 3.2.5. If the results of at least two of the three operations described in paragraph 3.2.4 above do not satisfy the requirements of paragraph 3.2.2 above, or if the verification cannot take place because the vehicle manufacturer has failed to supply information regarding the position of the 'R' point or regarding the design torso angle, the centroid of the three measured points or the average of the three measured angles shall be used and be regarded as applicable in all cases where the 'R' point or the design torso angle is referred to in this Regulation.

### 4. PROCEDURE FOR 'H' POINT AND ACTUAL TORSO ANGLE DETERMINATION

- 4.1. The vehicle shall be preconditioned at the manufacturer's discretion, at a temperature of  $20 \pm 10$  degrees C to ensure that the seat material reaches the room temperature. If the seat to be checked has never been sat upon, a 70 to 80 kg person or device shall sit on the seat twice for one minute to flex the cushion and back. At the manufacturer's request, all seat assemblies shall remain unloaded for a minimum period of 30 min prior to installation of the 3-D H machine.
- 4.2. The vehicle shall be at the measuring attitude defined in paragraph 2.11 above.
- 4.3. The seat, if it is adjustable, shall be adjusted first to the rearmost normal driving or riding position, as indicated by the vehicle manufacturer, taking into consideration only the longitudinal adjustment of the seat, excluding seat travel used for purposes other than normal driving or riding positions. Where other modes of seat adjustment exist (vertical, angular, seat-back, etc.) these will be then adjusted to the position specified by the vehicle manufacturer. For suspension seats, the vertical position shall be rigidly fixed corresponding to a normal driving position as specified by the manufacturer.
- 4.4. The area of the seating position contacted by the 3-D H machine shall be covered by a muslin cotton, of sufficient size and appropriate texture, described as a plain cotton fabric having 18,9 threads per cm<sup>2</sup> and weighing 0,228 kg/m<sup>2</sup> or knitted or non-woven fabric having equivalent characteristics.

If test is run on a seat outside the vehicle, the floor on which the seat is placed shall have the same essential characteristics <sup>(1)</sup> as the floor of the vehicle in which the seat is intended to be used.

<sup>(1)</sup> Tilt angle, height difference with a seat mounting, surface texture, etc.

- 4.5. Place the seat and back assembly of the 3-D H machine so that the centreplane of the occupant (C LO) coincides with the centreplane of the 3-D H machine. At the manufacturer's request, the 3-D H machine may be moved inboard with respect to the C LO if the 3-D H machine is located so far outboard that the seat edge will not permit levelling of the 3-D H machine.
- 4.6. Attach the foot and lower leg assemblies to the seat pan assembly, either individually or by using the T-bar and lower leg assembly. A line through the 'H' point sight buttons shall be parallel to the ground and perpendicular to the longitudinal centreplane of the seat.
- 4.7. Adjust the feet and leg positions of the 3-D H machine as follows:
  - 4.7.1. Designated seating position: driver and outside front passenger
    - 4.7.1.1. Both feet and leg assemblies shall be moved forward in such a way that the feet take up natural positions on the floor, between the operating pedals if necessary. Where possible the left foot shall be located approximately the same distance to the left of the centreplane of the 3-D H machine as the right foot is to the right. The spirit level verifying the transverse orientation of the 3-D H machine is brought to the horizontal by readjustment of the seat pan if necessary, or by adjusting the leg and foot assemblies towards the rear. The line passing through the 'H' point sight buttons shall be maintained perpendicular to the longitudinal centreplane of the seat.
    - 4.7.1.2. If the left leg cannot be kept parallel to the right leg and the left foot cannot be supported by the structure, move the left foot until it is supported. The alignment of the sight buttons shall be maintained.
  - 4.7.2. Designated seating position: outboard rear

For rear seats or auxiliary seats, the legs are located as specified by the manufacturer. If the feet then rest on parts of the floor which are at different levels, the foot which first comes into contact with the front seat shall serve as a reference and the other foot shall be so arranged that the spirit level giving the transverse orientation of the seat of the device indicates the horizontal.
  - 4.7.3. Other designated seating positions:

The general procedure indicated in paragraph 4.7.1 above shall be followed except that the feet shall be placed as specified by the vehicle manufacturer.
- 4.8. Apply lower leg and thigh weights and level the 3-D H machine.
- 4.9. Tilt the back pan forward against the forward stop and draw the 3-D H machine away from the seat-back using the T-bar. Reposition the 3-D H machine on the seat by one of the following methods:
  - 4.9.1. If the 3-D H machine tends to slide rearward, use the following procedure. Allow the 3-D H machine to slide rearward until a forward horizontal restraining load on the T-bar is no longer required, i.e. until the seat pan contacts the seat-back. If necessary, reposition the lower leg;
  - 4.9.2. If the 3-D H machine does not tend to slide rearward, use the following procedure. Slide the 3-D H machine rearwards by applying a horizontal rearward load to the T-bar until the seat pan contacts the seat-back (see figure 2 of Appendix 1 to this Annex).
- 4.10. Apply a 100 + 10 N load to the back and pan assembly of the 3-D H machine at the intersection of the hip angle quadrant and the T-bar housing. The direction of load application shall be maintained along a line passing by the above intersection to a point just above the thigh bar housing (see figure 2 of Appendix 1 to this Annex). Then carefully return the back pan to the seat-back. Care must be exercised throughout the remainder of the procedure to prevent the 3-D H machine from sliding forward.
- 4.11. Install the right and left buttock weights and then, alternately, the eight torso weights. Maintain the 3-D H machine level.
- 4.12. Tilt the back pan forward to release the tension on the seatback. Rock the 3-D H machine from side to side through 10° arc (5° to each side of the vertical centreplane) for three complete cycles to release any accumulated friction between the 3-D H machine and the seat.

During the rocking action, the T-bar of the 3-D H machine may tend to diverge from the specified horizontal and vertical alignment. The T-bar must therefore be restrained by applying an appropriate lateral load during the rocking motions. Care shall be exercised in holding the T-bar and rocking the 3-D H machine to ensure that no inadvertent exterior loads are applied in a vertical or fore and aft direction.

The feet of the 3-D H machine are not to be restrained or held during this step. If the feet change position, they should be allowed to remain in that attitude for the moment.

Carefully return the back pan to the seat-back and check the two spirit levels for zero position. If any movement of the feet has occurred during the rocking operation of the 3-D H machine, they must be repositioned as follows:

Alternately, lift each foot off the floor the minimum necessary amount until no additional foot movement is obtained. During this lifting, the feet are to be free to rotate; and no forward or lateral loads are to be applied. When each foot is placed back in the down position, the heel is to be in contact with the structure designed for this;

Check the lateral spirit level for zero position; if necessary, apply a lateral load to the top of the back pan sufficient to level the 3-D H machine's seat pan on the seat.

4.13. Holding the T-bar to prevent the 3-D H machine from sliding forward on the seat cushion, proceed as follows:

(a) return the back pan to the seat back;

(b) alternately apply and release a horizontal rearward load, not to exceed 25 N, to the back angle bar at a height approximately at the centre of the torso weights until the hip angle quadrant indicates that a stable position has been reached after load release. Care shall be exercised to ensure that no exterior downward or lateral loads are applied to the 3-D H machine. If another level adjustment of the 3-D H machine is necessary, rotate the back pan forward, re-level, and repeat the procedure from 4.12.

4.14. Take all measurements:

4.14.1. The coordinates of the 'H' point are measured with respect to the three-dimensional reference system;

4.14.2. The actual torso angle is read at the back angle quadrant of the 3-D H machine with the probe in its fully rearward position.

4.15. If a re-run of the installation of the 3-D H machine is desired, the seat assembly should remain unloaded for a minimum period of 30 min prior to the re-run. The 3-D H machine should not be left loaded on the seat assembly longer than the time required to perform the test.

4.16. If the seats in the same row can be regarded as similar (bench seat, identical seats, etc.) only one 'H' point and one 'actual torso angle' shall be determined for each row of seats, the 3-D H machine described in Appendix 1 to this Annex being seated in a place regarded as representative for the row. This place shall be:

4.16.1. in the case of the front row, the driver's seat;

4.16.2. in the case of the rear row or rows, an outer seat.

---



## Appendix 1

**Description of the three dimensional 'H' point machine (\*)**

(3-D H machine)

## 1. Back and seat pans

The back and seat pans are constructed of reinforced plastic and metal; they simulate the human torso and thigh and are mechanically hinged at the 'H' point. A quadrant is fastened to the probe hinged at the 'H' point to measure the actual torso angle. An adjustable thigh bar, attached to the seat pan, establishes the thigh centreline and serves as a baseline for the hip angle quadrant.

## 2. Body and leg elements

Lower leg segments are connected to the seat pan assembly at the T-bar joining the knees, which is a lateral extension of the adjustable thigh bar. Quadrants are incorporated in the lower leg segments to measure knee angles. Shoe and foot assemblies are calibrated to measure the foot angle. Two spirit levels orient the device in space. Body element weights are placed at the corresponding centres of gravity to provide seat penetration equivalent to a 76 kg male. All joints of the 3-D H machine should be checked for free movement without encountering noticeable friction.

The machine corresponds to that described in ISO Standard 6549-1980.

Figure 1

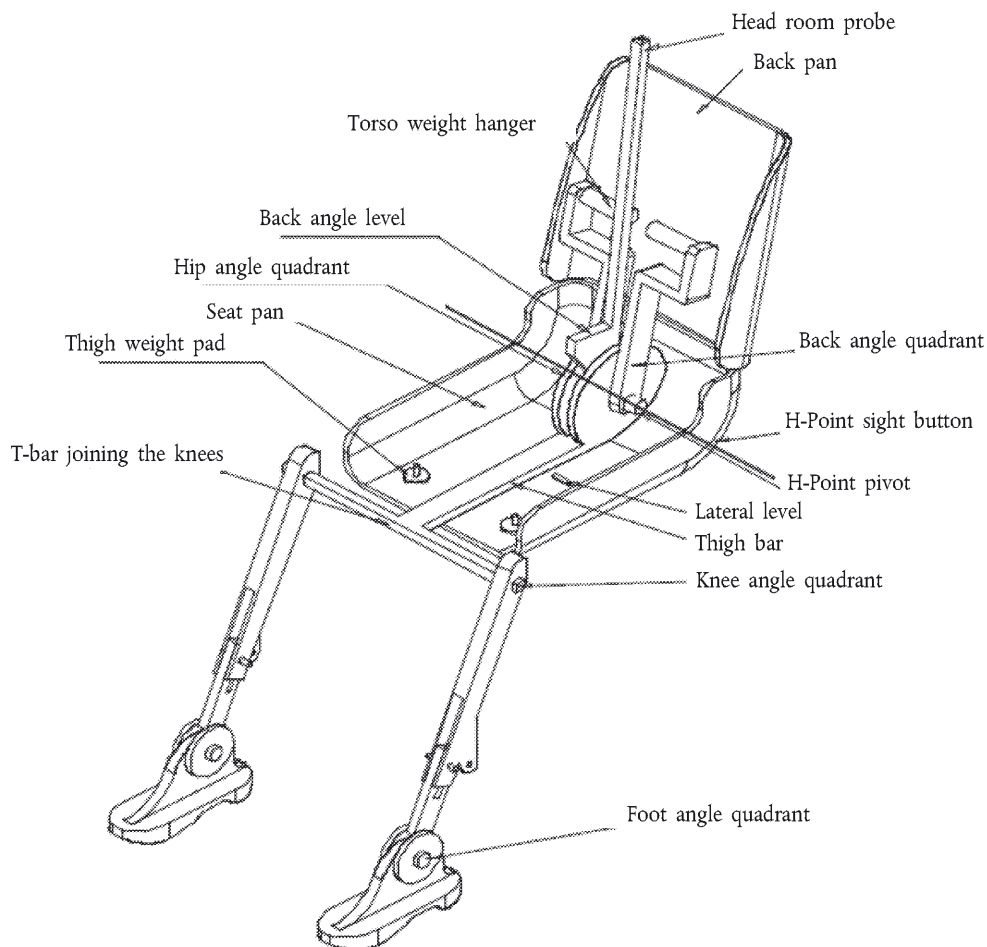
**3-D H machine elements designation**

(\*) For details of the construction of the 3-D H machine refer to Society of Automotive Engineers (SAE), 400 Commonwealth Drive, Warrendale, Pennsylvania 15096, United States of America.

Figure 2

Dimensions of the 3-D H machine elements and load distribution

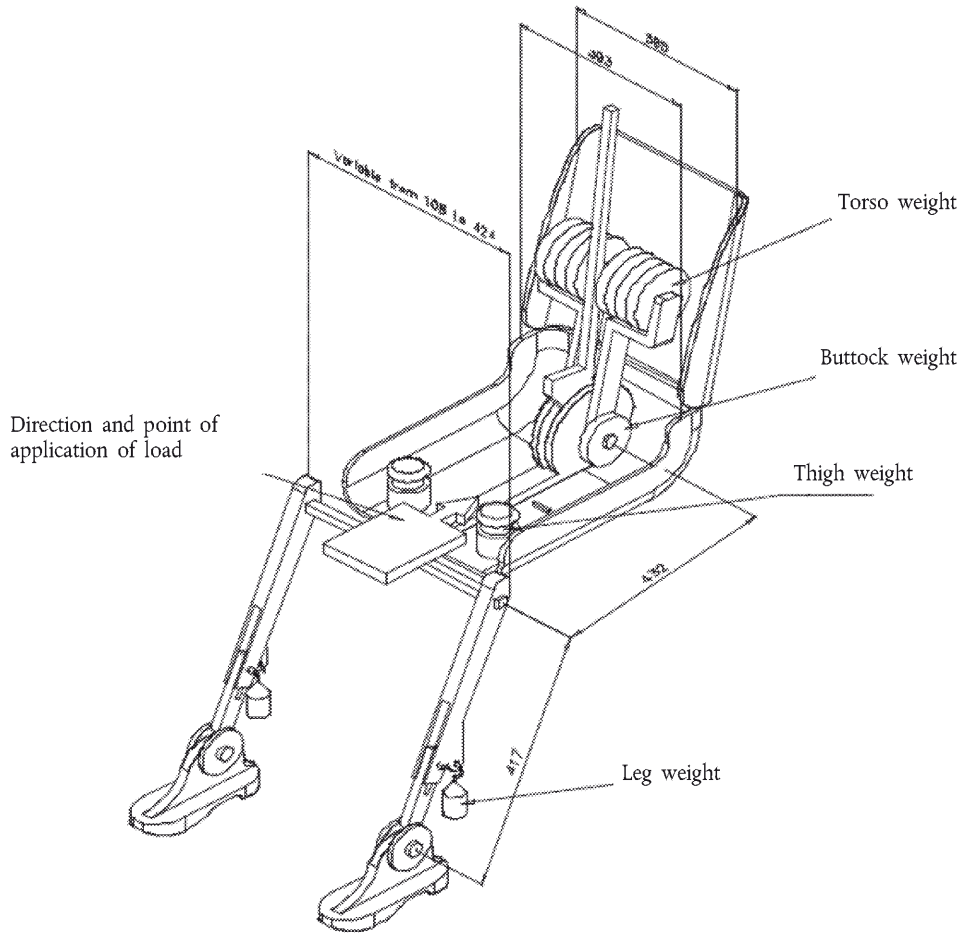

## Appendix 2

**THREE-DIMENSIONAL REFERENCE SYSTEM**

1. The three-dimensional reference system is defined by three orthogonal planes established by the vehicle manufacturer (see figure) (\*).
2. The vehicle measuring attitude is established by positioning the vehicle on the supporting surface such that the coordinates of the fiducial marks correspond to the values indicated by the manufacturer.
3. The coordinates of the 'R' point and the 'H' point are established in relation to the fiducial marks defined by the vehicle manufacturer.

Figure

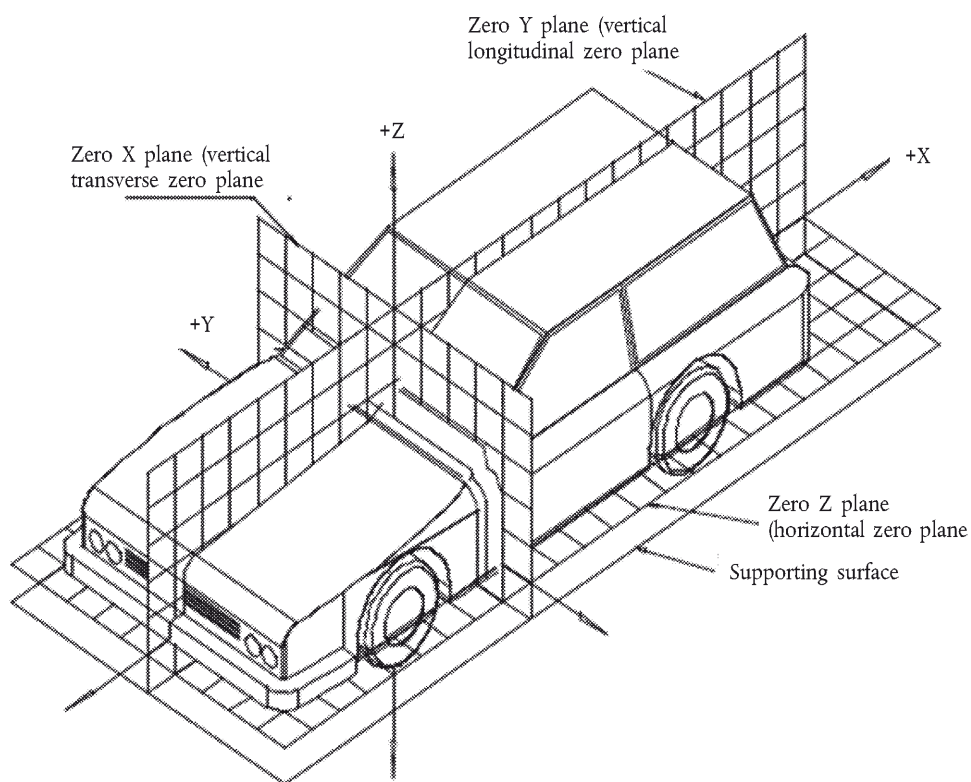
**Three-dimensional reference system**

(\*) The reference system corresponds to ISO standard 4130, 1978.

## Appendix 3

**REFERENCE DATA CONCERNING SEATING POSITIONS**

## 1. Coding of reference data

Reference data are listed consecutively for each seating position. Seating positions are identified by a two-digit code. The first digit is an Arabic numeral and designates the row of seats, counting from the front to the rear of the vehicle. The second digit is a capital letter which designates the location of the seating position in a row, as viewed in the direction of forward motion of the vehicle; the following letters shall be used:

L = left

C = centre

R = right

## 2. Description of vehicle measuring attitude

## 2.1. Coordinates of fiducial marks

X .....

Y .....

Z .....

## 3. List of reference data

## 3.1. Seating position: .....

## 3.1.1. Co-ordinates of 'R' point

X .....

Y .....

Z .....

## 3.1.2. Design torso angle .....

## 3.1.3. Specifications for seat adjustment (\*)

horizontal: .....

vertical: .....

angular: .....

torso angle: .....

Note: List reference data for further seating positions under 3.2, 3.3, etc.

---

(\*) Strike out what does not apply.

ANNEX 4

Determination of height and width of head restraint

Figure 1

Height

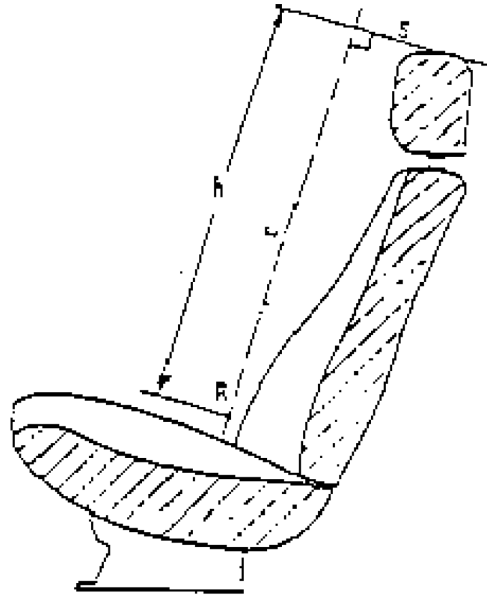
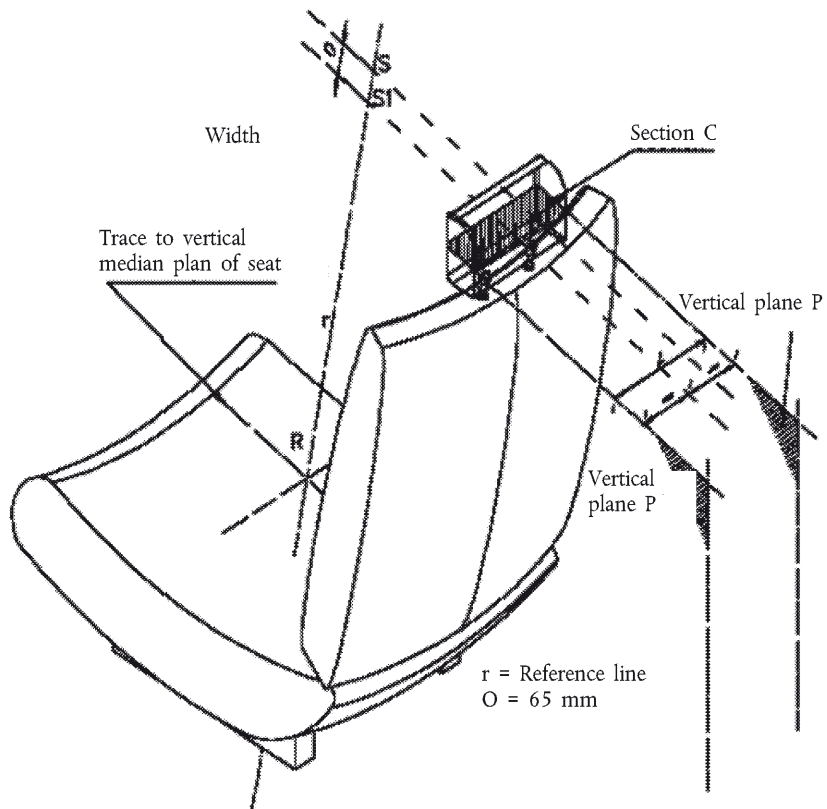
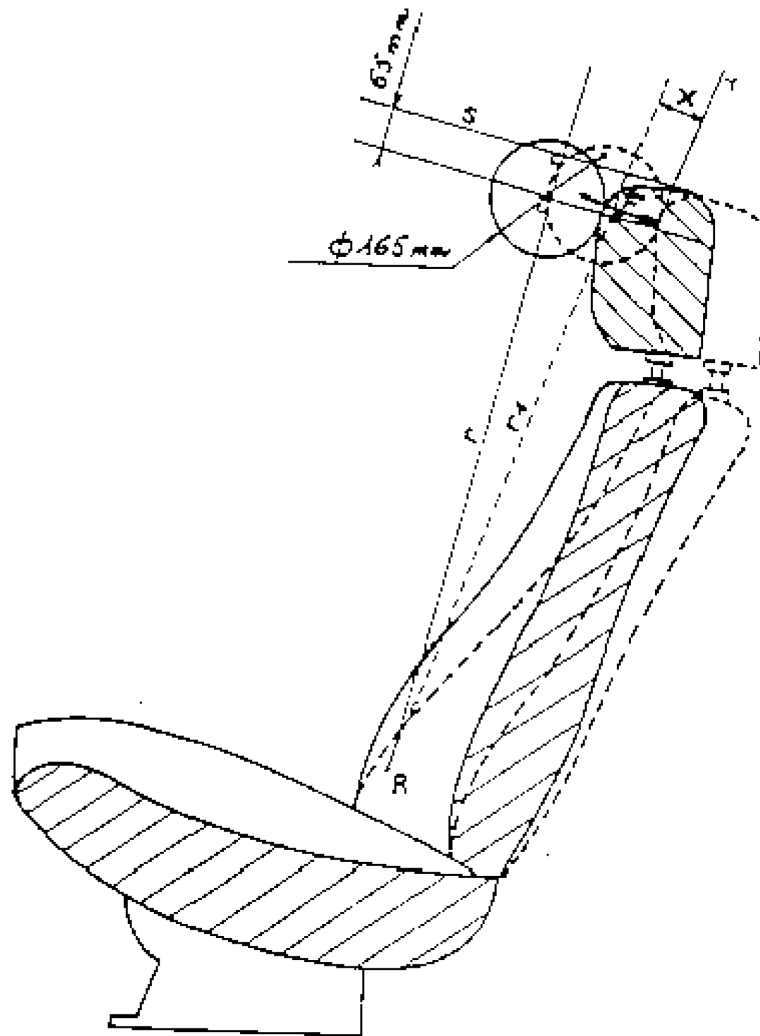

Figure 2



## ANNEX 5

## Details of lines drawn and measurements taken during tests



\_\_\_\_\_ Outline of Initial position

----- Outline of Position under load

r: reference line

r1: displaced reference line

Moment of F in relation to r: 37,3 daNm

## ANNEX 6

**TEST PROCEDURE FOR CHECKING ENERGY DISSIPATION**

## 1. Installation, test apparatus, recording instruments and procedure

## 1.1. Installation

The head restraint covered with an energy dissipating material shall be fitted and tested on the seat or the structural part of the vehicle in which it is installed. The structural component shall be firmly secured to the test bench so as to remain stationary when the impact is applied, and the base on which it rests shall, in the absence of a particular specification for which reasons are given, be approximately horizontal. The seat back, if it can be adjusted, shall be bolted into the position described in paragraph 7.2.2 of this Regulation.

The head restraint shall be mounted on the seat back, as it is presented in the vehicle. In the case of a separate head restraint, it shall be secured to the part of the vehicle structure to which it is normally secured.

If the head restraint is adjustable it shall be placed in the most unfavourable position the adjustment device permits.

## 1.2. Test apparatus

1.2.1. This apparatus consists of a pendulum whose pivot is supported by ball-bearings and whose reduced mass (\*) at its centre of percussion is 6,8 kg. The lower extremity of the pendulum consists of a rigid headform 165 mm in diameter whose centre is identical with the centre of percussion of the pendulum.

1.2.2. The headform shall be fitted with two accelerometers and a speed-measuring device, all capable of measuring values in the direction of impact.

## 1.3. Recording instruments

The recording instruments used shall be such that measurements can be made with the following degrees of accuracy:

## 1.3.1. Acceleration:

accuracy =  $\pm 5\%$  of the actual value

frequency class of the measurement chain: CFC 600 corresponding to the characteristics of ISO standard 6487 (1987)

Transverse sensitivity  $\leq 5\%$  of the lowest point on the scale.

## 1.3.2. Speed:

accuracy =  $\pm 2,5\%$  of the real value;

sensitivity = 0,5 km/h

## 1.3.3. Time recording

the instrumentation shall enable the action to be recorded throughout its duration and readings to be made within one one-thousandth of a second:

the beginning of the impact at the moment of first contact between the headform and the item being tested shall be detected on the recordings used for analysing the test.

## 1.4. Test procedure

1.4.1. With the head restraint installed and adjusted as indicated in paragraph 1.1 of this Annex, the impact shall take place at points selected by the laboratory in the impact zone defined in paragraph 6.1 of this Regulation and possibly outside the impact zone defined in paragraph 6.2 of this Regulation on surfaces with a radius of curvature of less than 5 mm.

(\*) The relationship of the reduced mass 'm<sub>r</sub>' of the pendulum to the total mass 'm' of the pendulum at a distance 'a' between the centre of percussion and the axis of rotation and at a distance 'l' between the centre of gravity and the axis of rotation is given by the formula:  
 $m_r = m (l/a)$ .

- 1.4.1.1. On the rear surface, the direction of impact from the rear towards the front in a longitudinal plane shall be at an angle of 45° to the vertical.
  - 1.4.1.2. On the front surface, the direction of impact from the front towards the rear, in a longitudinal plane, shall be horizontal.
  - 1.4.1.3. The front and rear zones are bounded by the horizontal plane tangential to the top of the head restraint as determined in paragraph 7.2 of this Regulation.
  - 1.4.2. The headform shall strike the test item at a speed of 24,1 km/h; this speed shall be achieved either by the mere energy of propulsion or by using an additional impelling device.
2. Results

In tests carried out by the above procedure the deceleration of the headform shall not exceed 80 g continuously for more than 3 milliseconds. The deceleration rate shall be taken as the average of the readings on the two decelerometers.
  3. Equivalent procedures
    - 3.1. Equivalent test procedures shall be permitted on condition that the results required in paragraph 2 above can be obtained, in particular, items of test apparatus may be oriented differently so long as the relative angles between the head restraint and the direction of impact are respected.
    - 3.2. Responsibility for demonstrating the equivalence of a method other than that described in paragraph 1 shall rest with the person using that other method.
-



## ANNEX 7

**Determination of dimension 'A' of head restraint gaps**

(see paragraphs 6.6.2 and 6.6.3 of this Regulation)

Figure 1

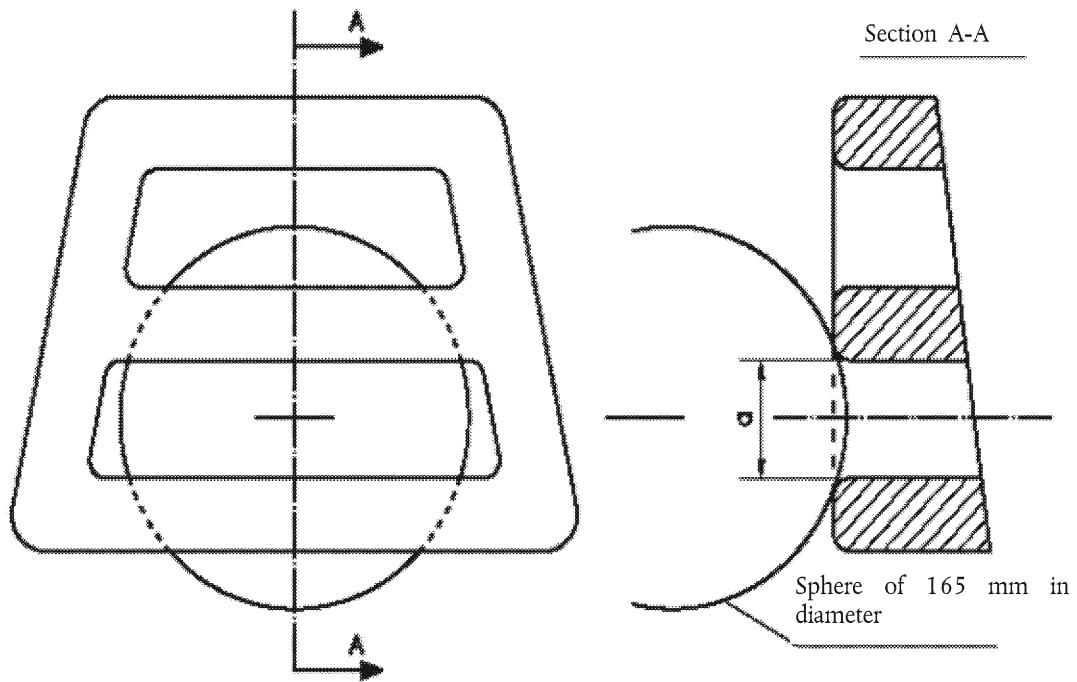
**Example of horizontal gaps**

Note: Section A-A is to be made in a point of the gap area which allows the maximum sphere intrusion, without exerting any load.

Figure 2  
Example of vertical gaps

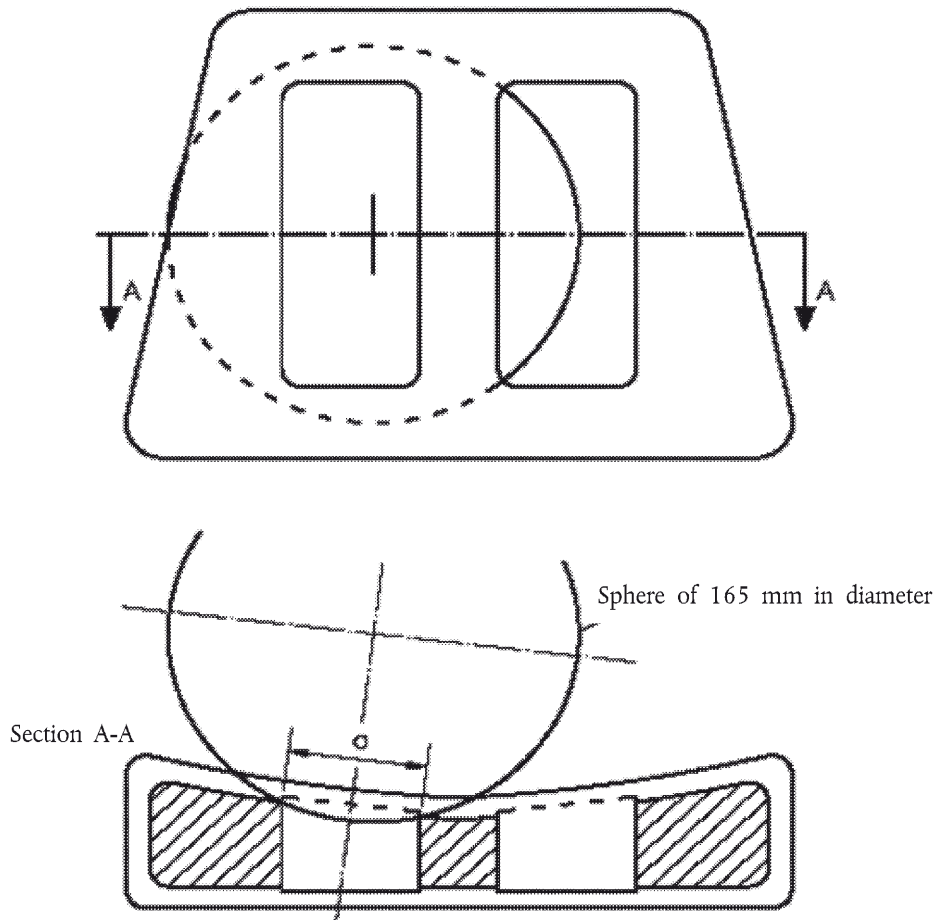

Note: Section A-A is to be made in a point of the gap area which allows the maximum sphere intrusion, without exerting any load.

\_\_\_\_\_