

Only the original UN/ECE texts have legal effect under international public law. The status and date of entry into force of this Regulation should be checked in the latest version of the UN/ECE status document TRANS/WP.29/343, available at:

<http://www.unece.org/trans/main/wp29/wp29wgs/wp29gen/wp29fdocstts.html>

Regulation No 91 of the Economic Commission for Europe of the United Nations (UN/ECE) — Uniform provisions concerning the approval of side-marker lamps for motor vehicles and their trailers

Incorporating all valid text up to:

Supplement 11 to the original version of the Regulation — Date of entry into force: 15 October 2008

CONTENTS

REGULATION

1. Scope
2. Definitions
3. Application for approval
4. Markings
5. Approval
6. General specifications
7. Intensity of light emitted
8. Colour of light emitted
9. Test procedure
10. Modification of a side-marker lamp type and extension of approval
11. Conformity of production
12. Penalties for non-conformity of production
13. Production definitely discontinued
14. Names and addresses of technical services responsible for conducting approval tests, and of administrative departments
15. Transitional provisions

ANNEXES

- Annex 1 — Minimum angles required for light distribution in space
- Annex 2 — Communication concerning the approval or refusal or extension or withdrawal of approval or production definitely discontinued of a type of side-marker lamp marked SM1/SM2
- Annex 3 — Arrangements of approval marks
- Annex 4 — Photometric measurements
- Annex 5 — Colour of lights emitted: light for trichromatic coordinates
- Annex 6 — Minimum requirements for conformity of production control procedures
- Annex 7 — Minimum requirements for sampling by an inspector

1. SCOPE

This Regulation applies to side-marker lamps for vehicles of category M, N, O and T ⁽¹⁾.

⁽¹⁾ As defined in Annex 7 to the Consolidated Resolution on the Construction of Vehicles (R.E.3), (document TRANS/WP.29/78/Rev.1/Amend.2 as last amended by Amend.4).

2. DEFINITIONS

2.1. The definitions given in Regulation No 48 and the series of amendments in force at the time of application for the type of approval shall apply to this Regulation.

2.2. 'Side-marker lamp' means a lamp used to indicate the presence of the vehicle when viewed from the side;

2.3. 'Side-marker lamps of different types' means lamps which differ in such essential respects as:

(a) the trade name or mark;

(b) the characteristics of the optical system (level of intensity, light distribution angles, category of filament lamp, light source module, etc.).

A change of the colour of the filament lamp or the colour of any filter does not constitute a change of type.

2.4. References made in this Regulation to standard (étalon) filament lamp(s) and to Regulation No 37 shall refer to Regulation No 37 and its series of amendments in force at the time of application for type approval.

3. APPLICATION FOR APPROVAL

3.1. The application for approval shall be submitted by the holder of the trade name or mark or by his duty accredited representative.

At the choice of the applicant, it will specify that the device may be installed on the vehicle with different inclinations of the reference axis in respect to the vehicle reference planes and to the ground or rotate around its reference axis; these different conditions of installation shall be indicated in the communication form. It shall specify:

3.1.1. whether the side-marker lamp is intended to emit amber or red light.

3.2. For each type of side-marker lamp the application shall be accompanied by:

3.2.1. Drawings in triplicate, sufficiently detailed to permit identification of the type of lamp and showing geometrically in what position(s) it may be mounted on the vehicle; the axis of observation to be taken as the axis of reference in the tests (horizontal angle $H = 0^\circ$, vertical angle $V = 0^\circ$); the point to be taken as the centre of reference in the said tests; the vertical and horizontal tangents to the illuminating surface and their distances from the centre of reference of the lamp. The drawings shall show the position intended for the approval number and the additional symbols in relation to the circle of the approval mark.

3.2.2. a brief technical description stating, in particular, with the exception of lamps with non-replaceable light sources:

(a) the category or categories of filament lamp(s) prescribed; this filament lamp category shall be one of those contained in Regulation No 37 and its series of amendments in force at the time of application for type approval; and/or

(b) the light source module specific identification code.

3.2.3. Two samples; if the application is made for side-marker lamps which are not identical but are symmetrical and suitable for mounting one on the left and one on the right side of the vehicle and/or, alternatively, one towards the front and one towards the rear, the two samples submitted may be identical and be suitable for mounting only on the right or only on the left side of the vehicle and/or, alternatively, only towards the front or only towards the rear.

4. MARKINGS

- 4.1. Side-marker lamps submitted for approval:
- 4.2. Must bear the trade name or mark of the applicant; this marking must be clearly legible and indelible;
- 4.3. With the exception of lamps with non-replaceable light sources must bear a clearly legible and indelible marking indicating:
 - (a) the category or categories of filament lamp(s) prescribed; and/or
 - (b) the light source module specific identification code.
- 4.4. Must comprise a space of sufficient size for the approval marking and the additional symbols prescribed in paragraph 5.4 below; this space shall be shown in the drawings mentioned in paragraph 3.2.1 above;
- 4.5. In the case of lamps with non-replaceable light sources or light source module(s), shall bear the marking of rated voltage or the range of voltages, and the rated wattage.
- 4.6. In the case of lamps with light source module(s), the light source module(s) shall bear:
 - 4.6.1. the trade name or mark of the applicant; this marking must be clearly legible and indelible;
 - 4.6.2. the specific identification code of the module; this marking must be clearly legible and indelible. This specific identification code shall comprise the starting letters 'MD' for 'MODULE' followed by the approval marking without the circle as prescribed in paragraph 5.4.1.1 below and, in the case several non identical light source modules are used, followed by additional symbols or characters; this specific identification code shall be shown in the drawings mentioned in paragraph 3.2.1 above.

The approval marking does not have to be the same as the one on the lamp in which the module is used, but both markings shall be from the same applicant.

- 4.6.3. the marking of the rated voltage (and rated wattage).
- #### 5. APPROVAL
- 5.1. If the two side-marker lamps submitted for approval pursuant to paragraph 3.2.3 above satisfy the provisions of this Regulation, approval shall be granted.
 - 5.2. An approval number shall be assigned to each type approved. Its first two digits shall indicate the series of amendments incorporating the most recent major technical amendments made to the Regulation at the time of issue of the approval. The same Contracting Party shall not assign this number to another type of side-marker lamp covered by this Regulation except in the case of the extension of the approval to a side-marker lamp differing only in the colour of the light emitted.
 - 5.3. Notice of approval or of extension or of refusal of approval of a type of side-marker lamp shall be communicated to the Parties to the Agreement which apply this Regulation, by means of a form conforming to the model in Annex 2 to this Regulation.
 - 5.4. Every side-marker lamp conforming to a type approved under this Regulation shall bear, in the space referred to in paragraph 4.4 above, and in addition to the markings prescribed in paragraphs 4.2 and 4.3 or 4.4 respectively:

- 5.4.1. an international approval mark consisting of:
 - 5.4.1.1. a circle surrounding the letter 'E' followed by distinguishing number of the country which has granted the approval ⁽¹⁾, and
 - 5.4.1.2. the approval number prescribed in paragraph 5.2 above.
- 5.4.2. The additional symbol 'SM1' or 'SM2'.
- 5.4.3. The two digits of the approval number which indicate the series of amendments in force on the date of issue of the approval may be marked close to the above additional symbol.
- 5.4.4. On devices with reduced light distribution in conformity to paragraph 2.5 in Annex 4 to this Regulation a vertical arrow starting from a horizontal segment and directed downwards.
- 5.5. The marks and symbols mentioned in paragraphs 5.4.1 to 5.4.3 above shall be indelible and clearly legible even when the device is mounted on the vehicle.
- 5.6. Where grouped, combined or reciprocally incorporated lamps have been found to comply with the requirements of several Regulations, a single international approval mark may be applied provided that such lamps are not grouped, combined or reciprocally incorporated with a lamp or lamps not satisfying any one of those Regulations.
 - 5.6.1. The approval mark shall consist of a circle surrounding the letter 'E' followed by the distinguishing number of the country which has granted the approval; an approval mark may be located anywhere on the grouped, combined or reciprocally incorporated lamps provided that:
 - 5.6.1.1. It is visible after their installation;
 - 5.6.1.2. No part of the grouped, combined or reciprocally incorporated lamps that transmits light can be removed without at the same time removing the approval mark.
- 5.7. The identification symbol for each lamp appropriate to each Regulation under which approval has been granted, together with the corresponding series of amendments incorporating the most recent major technical amendments to the Regulation at the time of issue of approval shall be marked;
 - 5.7.1. either on the appropriate light-emitting surface, or
 - 5.7.2. in a group, in such a way that each lamp may be clearly identified (see three possible models in example 2 shown in Annex 3).

⁽¹⁾ 1 for Germany, 2 for France, 3 for Italy, 4 for the Netherlands, 5 for Sweden, 6 for Belgium, 7 for Hungary, 8 for the Czech Republic, 9 for Spain, 10 for Serbia, 11 for the United Kingdom, 12 for Austria, 13 for Luxembourg, 14 for Switzerland, 15 (vacant), 16 for Norway, 17 for Finland, 18 for Denmark, 19 for Romania, 20 for Poland, 21 for Portugal, 22 for the Russian Federation, 23 for Greece, 24 for Ireland, 25 for Croatia, 26 for Slovenia, 27 for Slovakia, 28 for Belarus, 29 for Estonia, 30 (vacant), 31 for Bosnia and Herzegovina, 32 for Latvia, 33 (vacant), 34 for Bulgaria, 35 (vacant), 36 for Lithuania, 37 for Turkey, 38 (vacant), 39 for Azerbaijan, 40 for The former Yugoslav Republic of Macedonia, 41 (vacant), 42 for the European Community (Approvals are granted by its Member States using their respective ECE symbol), 43 for Japan, 44 (vacant), 45 for Australia, 46 for Ukraine, 47 for South Africa, 48 for New Zealand, 49 for Cyprus, 50 for Malta, 51 for the Republic of Korea, 52 for Malaysia, 53 for Thailand, 54 and 55 (vacant), 56 for Montenegro, 57 (vacant) and 58 for Tunisia. Subsequent numbers shall be assigned to other countries in the chronological order in which they ratify or accede to the Agreement Concerning the Adoption of Uniform Technical Prescriptions for Wheeled Vehicles, Equipment and Parts which can be Fitted and/or be Used on Wheeled Vehicles and the Conditions for Reciprocal Recognition of Approvals Granted on the Basis of these Prescriptions, and the numbers thus assigned shall be communicated by the Secretary-General of the United Nations to the Contracting Parties to the Agreement.

- 5.8. The size of the components of a single approval mark shall not be less than the minimum size required for the smallest of the individual marks under which the approval was granted.
- 5.9. An approval number shall be assigned to each type approved. The same Contracting Party shall not assign the same number to another type of assembly covered by this Regulation.
- 5.10. Annex 3 to this Regulation gives examples of arrangements of approval marks for a single lamp (example 1) and for an assembly (example 2).
- 5.11. Lamps grouped with a type of headlamp of which the lens is also used for another type of headlamp. The provisions laid down in paragraphs 5.6 to 5.9 above are applicable.
- 5.11.1. However, if different types of headlamps or units of lamps including a headlamp comprise the same lens, the latter may bear the different approval marks relating to these types of headlamp or units of lamps, provided that the main body of the headlamp, even if it cannot be separated from the lens, bears the approval marks of the actual functions. If different types of headlamps comprise the same main body, the latter may bear the different approval marks.
- 5.11.2. Annex 3 to this Regulation gives examples of approval marks relating to lamps which are grouped with a headlamp (example 3).
- 5.12. The approval marking shall be clearly legible and indelible. It may be placed on an inner or outer part (transparent or not) of the device which cannot be separated from the transparent part of the device emitting the light. In any case the marking shall be visible when the device is fitted on the vehicle or when a movable part such as the hood or boot lid or a door is opened.
6. GENERAL SPECIFICATIONS
- 6.1. Each side-marker lamp submitted for approval shall conform to the specifications set out in paragraphs 7 and 8 of this Regulation.
- 6.2. Side-marker lamps shall be so designed and made that, in normal use, despite the vibrations to which they may then be subjected, their satisfactory operation continues to be ensured and they retain the characteristics prescribed by this Regulation.
- 6.3. In the case of light source modules, it shall be checked that:
- 6.3.1. The design of the light source module(s) shall be such as:
- (a) that each light source module can only be fitted in no other position than the designated and correct one and can only be removed with the use of tool(s);
- (b) if there are more than one light source module used in the housing for a device, light source modules having different characteristics can not be interchanged within the same lamp housing.
- 6.3.2. The light source module(s) shall be tamperproof.
- 6.4. In the case of replaceable filament lamp(s):
- 6.4.1. Any category or categories of filament lamp(s) approved according to Regulation No 37 may be used, provided that no restriction on the use is made in Regulation No 37 and its series of amendments in force at the time of application for type approval.
- 6.4.2. The design of the device shall be such that the filament lamp can be fixed in no other position but the correct one.
- 6.4.3. The filament lamp holder shall conform to the characteristics given in IEC Publication 60061. The holder data sheet relevant to the category of filament lamp used, applies.

7. INTENSITY OF LIGHT EMITTED

7.1. The intensity of the light emitted by each of the two samples submitted shall be:

Side-marker lamp category		SM1	SM2
7.1.1. Minimum intensity	In the axis of reference	4,0 cd	0,6 cd
	Within the specified angular field, other than above	0,6 cd	0,6 cd
7.1.2. Maximum intensity	Within the specified angular field ⁽¹⁾	25,0 cd	25,0 cd
7.1.3. Angular field	Horizontal	± 45 deg.	± 30 deg.
	Vertical	± 10 deg.	± 10 deg.

7.1.4. In the case of a lamp containing more than one light source:

the lamp shall comply with the minimum intensity required when any one light source has failed;

when all light sources are illuminated the maximum intensity specified may not be exceeded.

All light sources which are connected in series are considered to be one light source.

7.2. Outside the reference axis and within the angular fields defined in the diagrams in Annex 1 to this Regulation, the intensity of the light emitted by each of the two side-marker lamps supplied must:

7.2.1. In each direction corresponding to the points in the light distribution table reproduced in Annex 4 to this Regulation, be not less than the product of the minimum specified in paragraph 7.1 above by the percentage specified in the said table for the direction in question;

7.2.2. In no direction within the space from which the side-marker lamp is visible, exceed the maximum specified in paragraph 7.1 above;

7.2.3. The provisions of paragraph 2.2 of Annex 4 to this Regulation on local variations of intensity must be observed.

7.3. Annex 4, to which reference is made in paragraph 7.2.1 above, gives particulars of the measurement methods to be used.

8. COLOUR OF LIGHT EMITTED

8.1. The side-marker lamp must emit amber light; however it can emit red, if the rearmost side-marker lamp is grouped or combined or reciprocally incorporated with the rear position lamp, the rear end-outline marker lamp, the rear fog lamp, the stop lamp, or is grouped with or has part of the light emitting surface in common with the rear retro-reflector.

8.2. The colour of the light emitted inside the field of the light distribution grid defined at paragraph 2 of Annex 4 must be within the limits of the trichromatic coordinates prescribed for the colour in question when measured in accordance with Annex 5 to this Regulation. Outside this field no sharp variation of colour shall be observed.

9. TEST PROCEDURE

9.1. Measurements shall be carried out with a colourless standard filament lamp of the type recommended for the side-marker lamp and so regulated as to produce the reference luminous flux prescribed for this type of lamp, taking into account the provisions of paragraph 9.2 below.

⁽¹⁾ In addition, for red side-marker lamp, in the angular field from 60° to 90° in horizontal direction and ± 20° in vertical direction towards the front of the vehicle, the maximum intensity is limited to 0,25 cd.

- 9.2. All measurements on lamps equipped with non-replaceable light sources (filament lamps and other) shall be made at 6,75 V, 13,5 V or 28,0 V respectively.

In the case of light sources supplied by a special power supply, the above test voltages shall be applied to the input terminals of that power supply. The test laboratory may require from the manufacturer the special power supply needed to supply the light sources.

- 9.3. The limits of the apparent surface in the direction of the reference axis of a light-signalling device shall be determined.

10. MODIFICATION OF SIDE-MARKER LAMP TYPE AND EXTENSION OF APPROVAL

- 10.1. Any modification of a side-marker lamp type shall be notified to the administration authority which approved the lamp. The authority may then either:

10.1.1. consider that the modifications are unlikely to have an appreciable adverse effect and that, in any case, the side-maker lamp still meets the requirements; or

10.1.2. require a further test report from the technical service responsible for conducting the tests.

10.2. Confirmation or refusal of approval, specifying the alterations, shall be communicated by the procedure specified in paragraph 5.3 above to the Parties to the Agreement which apply this Regulation.

10.3. The Competent Authority issuing the extension of approval shall assign a series number to each communication form drawn up for such an extension and inform thereof the other Parties to the Agreement applying this Regulation by means of a communication form conforming to the model in Annex 2 to this Regulation.

11. CONFORMITY OF PRODUCTION

The conformity of production procedures shall comply with those set out in the Agreement, Appendix 2 (E/ECE/324-E/ECE/TRANS/505/Rev.2), with the following requirements:

11.1. Any side-marker lamp approved according to this Regulation shall be so manufactured as to conform to the type approved by meeting the requirements set forth in paragraphs 7 and 8 above.

11.2. The minimum requirements for conformity of production control procedures set forth in Annex 6 to this Regulation shall be complied with.

11.3. The minimum requirements for sampling by an inspector set forth in Annex 7 to this Regulation shall be complied with.

11.4. The authority which has granted type approval may at any time verify the conformity control methods applied in each production facility. The normal frequency of these verifications shall be once every two years.

12. PENALTIES FOR NON-CONFORMITY OF PRODUCTION

12.1. The approval granted in respect of a side-marker lamp may be withdrawn if the foregoing conditions are not satisfied.

12.2. If a Party to the Agreement applying this Regulation withdraws an approval it has previously granted, it shall forthwith so notify the other Contracting Parties applying this Regulation, by means of a communication form conforming to the model in Annex 2 to this Regulation.

13. PRODUCTION DEFINITELY DISCONTINUED

If the holder of an approval completely ceases to manufacture a side-marker lamp approved in accordance with this Regulation, he shall so inform the authority which granted the approval. Upon receiving the relevant communication, that authority shall inform the other Parties to the Agreement applying this Regulation, by means of a communication form conforming to the model in Annex 2 to this Regulation.

14. NAMES AND ADDRESSES OF TECHNICAL SERVICES RESPONSIBLE FOR CONDUCTING APPROVAL TESTS, AND OF ADMINISTRATIVE DEPARTMENTS

The Parties to the Agreement applying this Regulation shall communicate to the United Nations secretariat the names and addresses of the technical services responsible for conducting approval tests and of the administrative departments which grant approval and to which communication forms certifying approval or extension or refusal or withdrawal of approval, issued in other countries, are to be sent.

15. TRANSITIONAL PROVISIONS

15.1. As from the official date of entry into force of Supplement 3 to the Regulation, no Contracting Party applying this Regulation shall refuse to grant ECE approval under this Regulation as amended by Supplement 3.

15.2. As from 24 months after the date of entry into force of Supplement 3 to the Regulation, Contracting Parties applying this Regulation shall grant ECE approvals only if the type of side-marker lamp to be approved meets the requirements of this Regulation as amended by Supplement 3.

15.3. Contracting Parties applying this Regulation shall not refuse to grant extensions of approval to this Regulation in its original form and the subsequent supplements.

15.4. Contracting Parties applying this Regulation shall continue to grant approvals to those types of side-marker lamps which comply with the requirements of this Regulation in its original form and the subsequent supplements during the 12 months period which follows the date of entry into force of Supplement 3 to this Regulation.

15.5. ECE approvals granted under this Regulation earlier than 12 months after the date of entry into force and all extensions of approvals, including those to this Regulation in its original form and the subsequent supplements granted subsequently, shall remain valid indefinitely. When the type of side-marker lamp approved to this Regulation in its original form and the subsequent supplements meets the requirements of this Regulation as amended by Supplement 3, the Contracting Party which granted the approval shall notify the other Contracting Parties applying this Regulation thereof.

15.6. No Contracting Party applying this Regulation shall refuse a type of side-marker lamp approved to Supplement 3 to this Regulation.

15.7. Until 36 months after the date of entry into force of Supplement 3 to this Regulation, no Contracting Party applying this Regulation shall refuse a type of side-marker lamp approved to the this Regulation in its original form and the subsequent supplements.

15.8. Starting 36 months after the date of entry into force of Supplement 3 to this Regulation, Contracting Parties applying this Regulation may refuse the sale of a type of side-marker lamp which does not meet the requirements of Supplement 3 to this Regulation unless the side-marker lamp is intended as a replacement for fitting on vehicles in use.

15.9. Contracting Parties applying this Regulation shall continue to issue approvals for side-marker lamps on the basis of any previous supplement to the Regulation, provided that these side-marker lamps are intended as replacements for fitting to vehicles in use.

15.10. As from the official date of entry into force of Supplement 3 to the Regulation, no Contracting Party applying this Regulation shall prohibit the fitting on a vehicle of a side-marker lamp approved under this Regulation as amended by Supplement 3 to this Regulation.

15.11. Contracting Parties applying this Regulation shall continue to allow the fitting on a vehicle of a side-marker lamp approved to this Regulation in its original form and the subsequent supplements during the 48 months period which follows the date of entry into force of Supplement 3 to the 00 series of amendments.

- 15.12. Upon the expiration of a period of 48 months after the date of entry into force of Supplement 3 to this Regulation, Contracting Parties applying this Regulation may prohibit the fitting of a side-marker lamp which does not meet the requirements of this Regulation as amended by Supplement 3 on a new vehicle for which national type or individual approval was granted more than 24 months after the date of entry into force of Supplement 3.
 - 15.13. Upon the expiration of a period of 60 months after the date of entry into force, Contracting Parties applying this Regulation may prohibit the fitting of a side-marker lamp which does not meet the requirements of this Regulation as amended by Supplement 3 on a new vehicle first registered more than 60 months after the date of entry into force of Supplement 3 to this Regulation.
-

ANNEX 1

MINIMUM ANGLES REQUIRED FOR LIGHT DISTRIBUTION IN SPACE

Minimum vertical angles, SM1 and SM2:

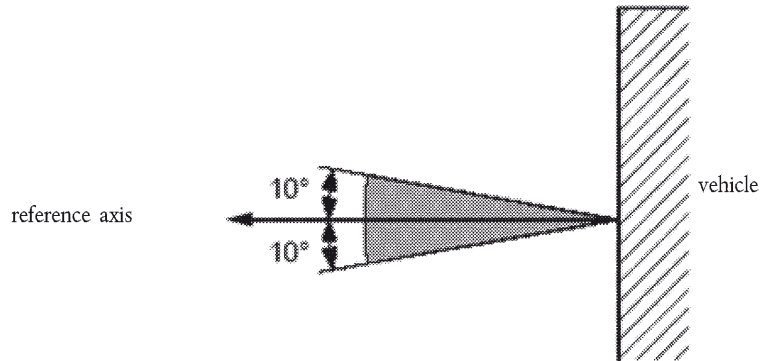

The angle of 10° below the horizontal may be reduced to 5° in case of lamps with a mounting height of equal to or less than 750 mm above the ground.

Minimum horizontal angles, SM1:

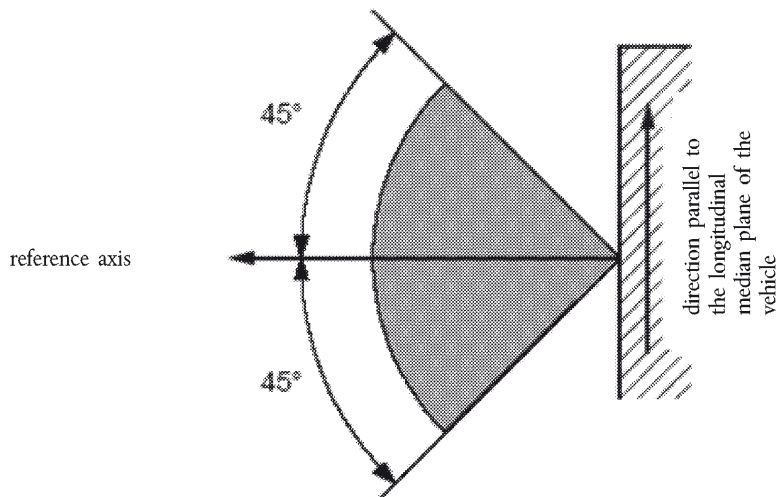

Minimum horizontal angles, SM2:

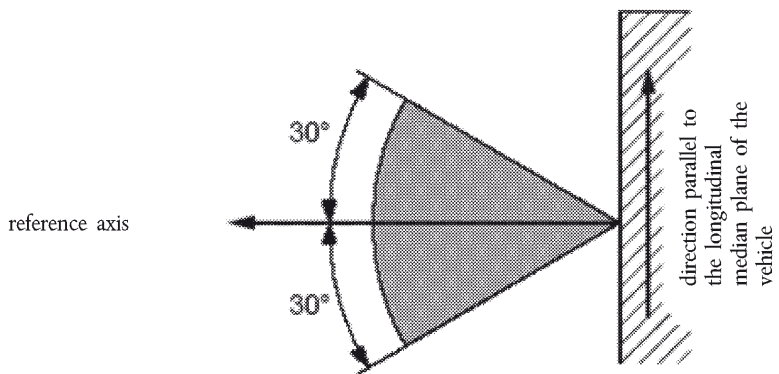

ANNEX 2

COMMUNICATION

(Maximum format: A4 (210 × 297 mm))



issued by: Name of administration

.....
.....
.....

- concerning ⁽²⁾: APPROVAL GRANTED
- APPROVAL EXTENDED
- APPROVAL REFUSED
- APPROVAL WITHDRAWN
- PRODUCTION DEFINITELY DISCONTINUED

of a type of side-marker lamp marked SM1/SM2 ⁽²⁾ pursuant to Regulation No 91

Approval No Extension No

1. Trade name or mark of the side-marker lamp:
2. manufacturer's name for the type of side-marker lamp:
3. Manufacturer's name and address:
4. If applicable, name and address of the manufacturer's representative:
5. Submitted for approval on:
6. Technical service responsible for conducting approval tests:
7. Date of test report:
8. Number of test report:
9. Concise description ⁽³⁾:
 Colour of light emitted: amber/red ⁽²⁾
 Number and category(ies) of filament lamp(s):
 Light source module: yes/no ⁽²⁾
 Light source module specific identification code:
 Geometrical conditions of installation and relating variations, if any:
10. Position of the approval mark:
11. Reason(s) for extension (if applicable):
12. Approval granted/refused/extended/withdrawn: ⁽²⁾
13. Place:
14. Date:
15. Signature:
16. The list of documents deposited with the administrative service which has granted approval is annexed to this communication and may be obtained on request.

⁽¹⁾ Distinguishing number of the country which has granted/extended/refused/withdrawn approval (see approval provisions in the Regulation).
⁽²⁾ Strike out what does not apply.
⁽³⁾ For lamps with non-replaceable light sources indicate the number and the total wattage of the light sources.

ANNEX 3

ARRANGEMENTS OF APPROVAL MARKS

Example 1(a)

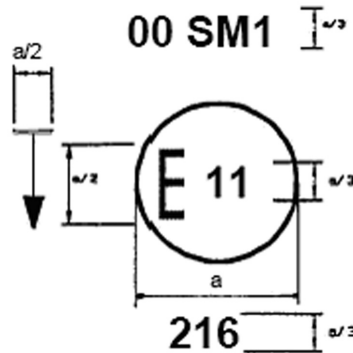

a = 5 mm min.

The device bearing the approval mark shown above is a side-marker lamp, approved in the United Kingdom (E11) pursuant to Regulation No 91 under the number 216. The vertical arrow starting from a horizontal segment and directed downwards indicates a permissible mounting height of equal to or less than 750 mm from the ground for this device.

Note: The number mentioned close to the symbol 'SM1' indicates that the approval was granted in accordance with the requirements of this Regulation in its original form.

Example 1(b)

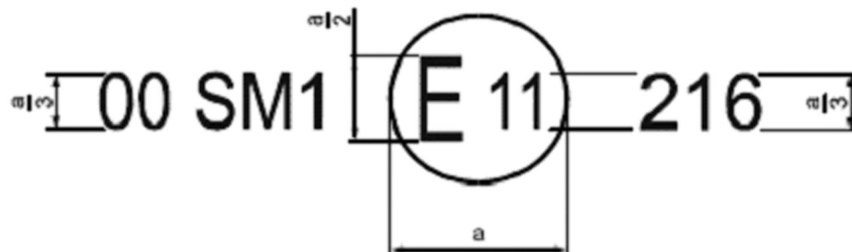

a = 5 mm min.

Example 2

Simplified marking for an assembly of several lamps that are part of the same unit

MODEL A

	3333 ⓔ ₁	IA 02	2a 01	A 01	SM1 00
		F 01	AR 01	S1 01	IA 02

MODEL B

		IA 2a A SM1 02 01 01 00 F AR S1 IA 01 01 01 02 3333		
		(E4)		

MODEL C

<table border="1" style="display: inline-table; vertical-align: middle;"> <tr> <td>IA</td><td>2a</td><td>A</td><td>SM1</td></tr> <tr> <td>02</td><td>01</td><td>01</td><td>00</td></tr> <tr> <td>F</td><td>AR</td><td>S1</td><td>IA</td></tr> <tr> <td>01</td><td>01</td><td>01</td><td>02</td></tr> </table> <p style="text-align: center;">3333</p> <p style="text-align: center;">(E1)</p>	IA	2a	A	SM1	02	01	01	00	F	AR	S1	IA	01	01	01	02				
	IA	2a	A	SM1																
02	01	01	00																	
F	AR	S1	IA																	
01	01	01	02																	

Note: The three examples of approval mark, models A, B, and C represent three possible variants of marking of a light-signalling device when two or more lamps are part of the same unit of grouped, combined or reciprocally incorporated lamps.

The approval mark shows that the device was approved in the Netherlands (E4) under 3333 and comprises:

A rear and a side retro-reflector of a class IA approved in accordance with Regulation No 3, 02 series of amendments;

A rear direction indicator lamp of category 2a approved in accordance with Regulation No 6, 01 series of amendments;

A rear position lamp (R) approved in accordance with Regulation No 7, 01 series of amendments;

A rear fog lamp (F) approved in accordance with Regulation No 38, 01 series of amendments;

A reversing lamp (AR) approved in accordance with Regulation No 23, 01 series of amendments;

A stop lamp (S1) approved in accordance with Regulation No 7, 01 series of amendments;

A side-marker lamp (SM1) approved in conformity with the present Regulation in its original form.

Lamp reciprocally incorporated as grouped with a headlamp

Example 3



The above example corresponds to the marking of a lens intended to be used in different types of headlamps, namely:

either: a headlamp with a passing beam designed for right-hand and left-hand traffic and a driving beam with a maximum intensity comprised between 86 250 and 101 250 candelas, approved in Germany (E1) in accordance with the requirements of Regulation No 8 as amended by the 02 series of amendments; which is reciprocally incorporated with a front direction indicator approved in accordance with the 01 series of amendments to Regulation No 6 and grouped with a side-marker lamp in accordance with this Regulation in the original form,

or: a headlamp with a passing beam designed for right-hand and left-hand traffic and a driving beam approved in Germany (E1) in accordance with the requirements of Regulation No 1 as amended by the 01 series of amendments, which is reciprocally incorporated with the same front direction indicator and the same side-marker lamp as above,

or even: either of the abovementioned headlamps approved as a single lamp.

The main body of the headlamp shall bear the only valid approval number, for instance:

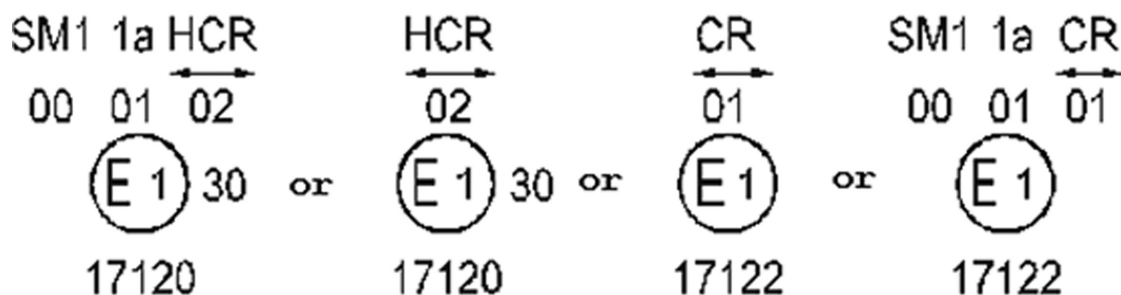

Example 4

Light source modules

MD E3 17325

The light source module bearing the identification code shown above has been approved together with a lamp approved in Italy (E3) under approval number 17325.

ANNEX 4

PHOTOMETRIC MEASUREMENTS

1. Measurement methods
 - 1.1. During photometric measurement stray reflections shall be avoided by appropriate masking.
 - 1.2. In case the results of measurements should be challenged, measurements shall be carried out in such a way as to meet the following requirements:
 - 1.2.1. The distance of measurement shall be such that the law of the inverse of the square of the distance is applicable;
 - 1.2.2. The measuring equipment shall be such that the angular aperture of the receiver viewed from the reference centre of the lamp is comprised between 10 minutes and 1 degree;
 - 1.2.3. The intensity requirement for a particular direction of observation shall be deemed to be satisfied if that requirement is met in a direction deviating by not more than one-quarter of a degree from the direction of observation.
 - 1.3. In the case where the device may be installed on the vehicle in more than one or in a field of different positions the photometric measurements shall be repeated for each position or for the extreme positions of the field of the reference axis specified by the manufacturer.
 - 1.4. The direction $H = 0^\circ$ and $V = 0^\circ$ corresponds to the reference axis. (On the vehicle it is horizontal, perpendicular to the median longitudinal plane of the vehicle and oriented in the required direction of visibility.) It passes through the centre of reference.
2. Tables of light distribution
 - 2.1. SM1 category of side-marker lamps

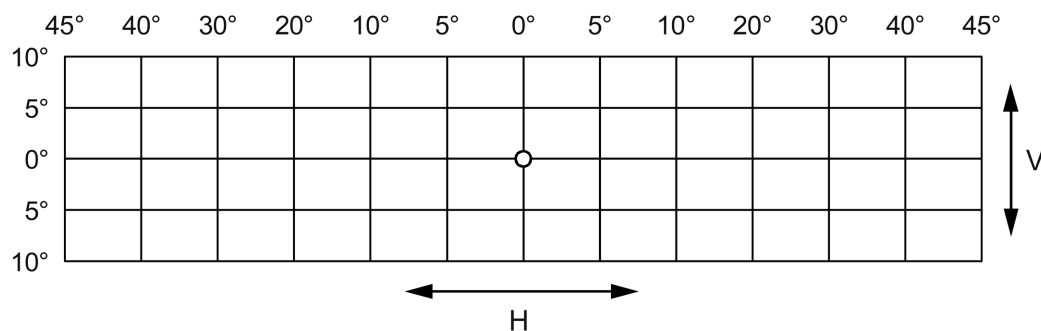

- 2.1.1. Minimum values:

0,6 cd at any point other than the reference axis, at which it shall be 4,0 cd.

- 2.1.2. Maximum values:

25,0 cd at any point

- 2.2. SM2 category of side-marker lamps

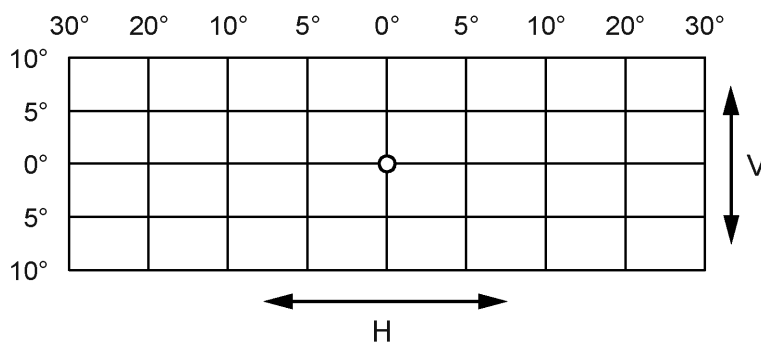

2.2.1. Minimum values:

0,6 cd, at any point

2.2.2. Maximum values:

25,0 cd, at any point

2.3. For SM1 and SM2 category of side-marker lamps it may be sufficient to check only five points selected by the test authority.

2.4. Within the field of light distribution shown above as a grid the light pattern should be substantially uniform, i.e. the light intensity in every direction within a part of the field formed by the grid lines shall meet at least the lowest minimum value applicable to the respective grid lines.

2.5. However, in the case where the device is intended to be installed at a mounting height of equal to or less than 750 mm above the ground, the photometric intensity is verified only up to an angle of 5° downwards.

3. Photometric measurement of lamps

The photometric performance shall be checked:

3.1. For non-replaceable light sources (filament lamps and other):

with the light sources present in the lamp, in accordance with paragraph 9.2 of this Regulation.

3.2. For replaceable filament lamps:

when equipped with filament lamps at 6,75 V, 13,5 V or 28,0 V the luminous intensity values produced shall be corrected. The correction factor is the ratio between the reference luminous flux and the mean value of the luminous flux found at the voltage applied (6,75 V, 13,5 V or 28,0 V). The actual luminous fluxes of each filament lamp used shall not deviate more than ± 5 per cent from the mean value. Alternatively a standard filament lamp may be used in turn, in each of the individual positions, operated at its reference flux, the individual measurements in each position being added together.

3.3. For any signalling lamp except those equipped with filament lamp(s), the luminous intensities, measured after one minute and after 30 minutes of operation, shall comply with the minimum and maximum requirements. The luminous intensity distribution after one minute of operation can be calculated from the luminous intensity distribution after 30 minutes of operation by applying at each test point the ratio of luminous intensities measured at HV after one minute and after 30 minutes of operation.

ANNEX 5

Colour of light emitted: lights for chromaticity coordinates

For checking the colorimetric characteristics, a source of light at a colour temperature of 2 856 K, corresponding to illuminant A of the International Commission on Illumination (CIE), shall be used. However, for lamps equipped with non-replaceable light sources (filament lamps and other), the colorimetric characteristics should be verified with the light sources present in the lamp, in accordance with paragraph 9.2 of this Regulation.

ANNEX 6

MINIMUM REQUIREMENTS FOR CONFORMITY OF PRODUCTION CONTROL PROCEDURES

1. GENERAL

- 1.1. The conformity requirements shall be considered satisfied from a mechanical and geometric standpoint, if the differences do not exceed inevitable manufacturing deviations within the requirements of this Regulation.
- 1.2. With respect to photometric performances, the conformity of mass-produced side-marker lamps shall not be contested if, when testing photometric performances of any side-marker lamp chosen at random and equipped with a standard filament lamp, or when the side-marker lamps are equipped with non-replaceable light sources (filament lamps or other), and when all measurements are made at 6,75 V, 13,5 V or 28,0 V respectively:
 - 1.2.1. no measured value deviates unfavourably by more than 20 per cent from the values prescribed in this Regulation.
 - 1.2.2. If, in the case of a side-marker lamp equipped with a replaceable light source and if results of the test described above do not meet the requirements, tests on side-marker lamps shall be repeated using another standard filament lamp.
- 1.3. The chromaticity coordinates shall be complied with when the side-marker lamp is equipped with a standard filament lamp, or for side-marker lamps equipped with non-replaceable light sources (filament lamps or other), when the colorimetric characteristics are verified with the light source present in the side-marker lamp.

2. MINIMUM REQUIREMENTS FOR VERIFICATION OF CONFORMITY BY THE MANUFACTURER

For each type of side-marker lamp the holder of the approval mark shall carry out at least the following tests, at appropriate intervals. The tests shall be carried out in accordance with the provisions of this Regulation.

If any sampling shows non-conformity with regard to the type of test concerned, further samples shall be taken and tested. The manufacturer shall take steps to ensure the conformity of the production concerned.

2.1. Nature of tests

Tests of conformity in this Regulation shall cover the photometric and colorimetric characteristics.

2.2. Methods used in tests

- 2.2.1. Tests shall generally be carried out in accordance with the methods set out in this Regulation.
- 2.2.2. In any test of conformity carried out by the manufacturer, equivalent methods may be used with the consent of the competent authority responsible for approval tests. The manufacturer is responsible for proving that the applied methods are equivalent to those laid down in this Regulation.
- 2.2.3. The application of paragraphs 2.2.1 and 2.2.2 requires regular calibration of test apparatus and its correlation with measurements made by a competent authority.
- 2.2.4. In all cases the reference methods shall be those of this Regulation, particularly for the purpose of administrative verification and sampling.

2.3. Nature of sampling

Samples of side-marker lamps shall be selected at random from the production of a uniform batch. A uniform batch means a set of side-marker lamps of the same type, defined according to the production methods of the manufacturer.

The assessment shall in general cover series production from individual factories. However, a manufacturer may group together records concerning the same type from several factories, provided these operate under the same quality system and quality management.

2.4. Measured and recorded photometric characteristics

The sampled lamp shall be subjected to photometric measurements for the minimum values at the points listed in Annex 4 and the required chromaticity coordinates.

2.5. Criteria governing acceptability

The manufacturer is responsible for carrying out a statistical study of the test results and for defining, in agreement with the competent authority, criteria governing the acceptability of his products in order to meet the specifications laid down for verification of conformity of products in paragraph 11.1 of this Regulation.

The criteria governing the acceptability shall be such that, with a confidence level of 95 per cent, the minimum probability of passing a spot check in accordance with Annex 7 (first sampling) would be 0,95.

ANNEX 7

MINIMUM REQUIREMENTS FOR SAMPLING BY AN INSPECTOR

1. GENERAL

- 1.1. The conformity requirements shall be considered satisfied from a mechanical and a geometric standpoint, in accordance with the requirements of this Regulation, if any, if the differences do not exceed inevitable manufacturing deviations.
- 1.2. With respect to photometric performance, the conformity of mass-produced side-marker lamps shall not be contested if, when testing photometric performances of any side-marker lamp chosen at random and equipped with a standard filament lamp, or when the side-marker lamps are equipped with non-replaceable light sources (filament lamps or other), and when all measurements are made at 6,75 V, 13,5 V or 28,0 V respectively:
- 1.2.1. no measured value deviates unfavourably by more than 20 per cent from the values prescribed in this Regulation.
- 1.2.2. If, in the case of a side-marker lamp equipped with a replaceable light source and if results of the test described above do not meet the requirements, tests on side-marker lamps shall be repeated using another standard filament lamp.
- 1.2.3. Side-marker lamps with apparent defects are disregarded.
- 1.3. The chromaticity coordinates shall be complied with when the side-marker lamp is equipped with a standard filament lamp, or for the side-marker lamps equipped with non-replaceable light sources (filament lamps or other), when the colorimetric characteristics are verified with the light source present in the side-marker lamp.

2. FIRST SAMPLING

In the first sampling four side-marker lamps are selected at random. The first sample of two is marked A, the second sample of two is marked B.

- 2.1. The conformity is not contested
- 2.1.1. Following the sampling procedure shown in Figure 1 of this Annex, the conformity of mass-produced side-marker lamps shall not be contested if the deviations of the measured values of the side-marker lamps in the unfavourable directions are:
- 2.1.1.1. sample A
- | | |
|--------------------------------------|-------------|
| A1: one side-marker lamp | 0 per cent |
| one side-marker lamp not more than | 20 per cent |
| A2: both side-marker lamps more than | 0 per cent |
| but not more than | 20 per cent |
| go to sample B | |
- 2.1.1.2. sample B
- | | |
|----------------------------|------------|
| B1: both side-marker lamps | 0 per cent |
|----------------------------|------------|
- 2.1.2. or, if the conditions of paragraph 1.2.2 for sample A are fulfilled.
- 2.2. The conformity is contested
- 2.2.1. Following the sampling procedure shown in Figure 1 of this annex the conformity of mass-produced side-marker lamps shall be contested and the manufacturer requested to make his production meet the requirements (alignment) if the deviations of the measured values of the side-marker lamps are:
- 2.2.1.1. sample A
- | | |
|----------------------------------------|-------------|
| A3: one side-marker lamp not more than | 20 per cent |
| one side-marker lamp more than | 20 per cent |
| but not more than | 30 per cent |

2.2.1.2. sample B

B2: in the case of A2	
one side-marker lamp more than	0 per cent
but not more than	20 per cent
one side-marker lamp not more than	20 per cent
B3: in the case of A2	
one side-marker lamp	0 per cent
one side-marker lamp more than	20 per cent
but not more than	30 per cent

2.2.2. or, if the conditions of paragraph 1.2.2 for sample A are not fulfilled.

2.3. Approval withdrawn

Conformity shall be contested and paragraph 12 applied if, following the sampling procedure in Figure 1 of this annex, the deviations of the measured values of the side-marker lamps are:

2.3.1. sample A

A4: one side-marker lamp not more than	20 per cent
one side-marker lamp more than	30 per cent
A5: both side-marker lamps more than	20 per cent

2.3.2. sample B

B4: in the case of A2	
one side-marker lamp more than	0 per cent
but not more than	20 per cent
one side-marker lamp more than	20 per cent
B5: in the case of A2	
both side-marker lamps more than	20 per cent
B6: in the case of A2	
one side-marker lamp	0 per cent
one side-marker lamp more than	30 per cent

2.3.3. or, if the conditions of paragraph 1.2.2 for samples A and B are not fulfilled.

3. REPEATED SAMPLING

In the cases of A3, B2, B3 a repeated sampling, third sample C of two side-marker lamps and fourth sample D of two side-marker lamps, selected from stock manufactured after alignment, is necessary within two months' time after the notification.

3.1. The conformity is not contested

3.1.1. Following the sampling procedure shown in Figure 1 of this annex the conformity of mass-produced side-marker lamps shall not be contested if the deviations of the measured values of the side-marker lamps are:

3.1.1.1. sample C

C1: one side-marker lamp	0 per cent
one side-marker lamp not more than	20 per cent
C2: both side-marker lamps more than	0 per cent
but not more than	20 per cent
go to sample D	

3.1.1.2. sample D

D1: in the case of C2	
both side-marker lamps	0 per cent

- 3.1.2. or, if the conditions of paragraph 1.2.2 for sample C are fulfilled.
- 3.2. The conformity is contested
- 3.2.1. Following the sampling procedure shown in Figure 1 of this annex the conformity of mass-produced side-marker lamps shall be contested and the manufacturer requested to make his production meet the requirements (alignment) if the deviations of the measured values of the side-marker lamps are:
- 3.2.1.1. sample D
- | | |
|------------------------------------|-------------|
| D2: in the case of C2 | |
| one side-marker lamp more than | 0 per cent |
| but not more than | 20 per cent |
| one side-marker lamp not more than | 20 per cent |
- 3.2.1.2. or, if the conditions of paragraph 1.2.2 for sample C are not fulfilled.
- 3.3. Approval withdrawn
- Conformity shall be contested and paragraph 12 applied if, following the sampling procedure in Figure 1 of this annex, the deviations of the measured values of the side-marker lamps are:
- 3.3.1. sample C
- | | |
|----------------------------------------|-------------|
| C3: one side-marker lamp not more than | 20 per cent |
| one side-marker lamp more than | 20 per cent |
| C4: both side-marker lamps more than | 20 per cent |
- 3.3.2. sample D
- | | |
|-------------------------------------|-------------|
| D3: in the case of C2 | |
| one side-marker lamp 0 or more than | 0 per cent |
| one side-marker lamp more than | 20 per cent |
- 3.3.3. or, if the conditions of paragraph 1.2.2 for samples C and D are not fulfilled.

Figure 1

