

## ACTS ADOPTED BY BODIES CREATED BY INTERNATIONAL AGREEMENTS

Only the original UN/ECE texts have legal effect under international public law. The status and date of entry into force of this Regulation should be checked in the latest version of the UN/ECE status document TRANS/WP.29/343, available at:  
<http://www.unece.org/trans/main/wp29/wp29wgs/wp29gen/wp29fdocstts.html>

### **Regulation No 34 of the Economic Commission for Europe of the United Nations (UN/ECE) — Uniform provisions concerning the approval of vehicles with regard to the prevention of fire risks**

#### **Addendum 33: Regulation No 34**

##### **Revision 1**

Incorporating all valid text up to:

Supplement 2 to the 02 series of amendments — Date of entry into force: 11 June 2007

#### CONTENTS

##### REGULATION

1. Scope
2. Application for approval
3. Approval
4. Definitions
5. Requirements for liquid fuel
6. Test of liquid fuel tanks
7. Definitions
8. Requirements for installation of an approved liquid fuel tank
9. Tests on the vehicle
10. Modifications of the vehicle type
11. Conformity of production
12. Penalties for non-conformity of production
13. Transitional provisions
14. Names and addresses of technical services conducting approval tests, and of administrative departments

##### ANNEXES

- Annex I — Communication concerning the approval or extension or refusal or withdrawal of approval or production definitely discontinued of a vehicle type with regard to the tank for liquid fuel and to the prevention of fire risks in the event of a frontal/lateral/rear collision pursuant to Regulation No 34
- Annex II — Arrangements of approval marks
- Annex III — Frontal collision test against a barrier
- Annex IV — Procedure for rear-end collision test
- Annex V — Testing of fuel tanks made of a plastic material
- Appendix 1 — Test of resistance to fire
- Appendix 2 — Dimensions and technical data of firebricks

## 1. SCOPE

This Regulation applies:

- 1.1. PART I: to the approval of vehicles of categories M, N and O <sup>(1)</sup> with regard to the tank(s) for liquid fuel.
- 1.2. PART II: at the request of the manufacturer to the approval of vehicles of categories M, N and O approved to Part I of this Regulation fitted with liquid fuel tank(s) with regard to the prevention of fire risks in the event of a frontal and/or lateral and/or rear collision.
- 1.3. At the request of the manufacturer, vehicles other than those above mentioned in paragraph 1.2 may be approved under this Regulation.

## 2. APPLICATION FOR APPROVAL

- 2.1. The application for approval of a vehicle type to a part of this Regulation shall be submitted by the vehicle manufacturer or by his duly accredited representative.
- 2.2. It shall be accompanied by the undermentioned documents in triplicate and by the following particulars:
  - 2.2.1. a detailed description of the vehicle type with respect to the items specified in paragraph 4.2 and/or 7.2. The numbers and/or symbols identifying the engine type and the vehicle type must be specified;
  - 2.2.2. drawing(s) showing the characteristics of the fuel tank and specifying the material from which it is made;
  - 2.2.3. a diagram of the entire fuel feed systems, showing the site of each component on the vehicle; and
  - 2.2.4. for application pursuant to Part II of this Regulation, a diagram of the electrical installation showing its siting and its mode of attachment to the vehicle.
- 2.3. The following must be submitted to the technical service responsible for conducting the type-approval tests:
  - 2.3.1. a vehicle representative of the vehicle type to be approved or the parts of the vehicle which the technical service deems necessary for approval tests;
  - 2.3.2. in the case of a vehicle equipped with a tank made of a plastic material: seven additional tanks, with their accessories;
  - 2.3.3. in the case of a vehicle equipped with a tank made of another material: two additional tanks, with their accessories.

## 3. APPROVAL

- 3.1. If the vehicle submitted for approval pursuant to this Regulation meets the requirements of Part I and/or Part II below, approval of that vehicle type shall be granted.

<sup>(1)</sup> As defined in Annex VII to the Consolidated Resolution on the Construction of Vehicles (R.E.3), (document TRANS/WP.29/78/Rev.1/Amend.2 as last amended by Amend.4).

- 3.2. Each type approved shall be assigned an approval number whose first two digits shall constitute the number of the most recent series of amendments incorporated in the Regulation on the date of issue of the approval. A Contracting Party may however assign the same approval number to several vehicle types as defined in paragraph 4.2 and/or 7.2 if the types are variants of the same basic model and provided that each type is separately tested and found to comply with the conditions of this Regulation.
- 3.3. Notice of approval or of refusal of approval of a vehicle type pursuant to this Regulation shall be communicated to the Parties to the Agreement which apply this Regulation by means of a form conforming to the model in Annex I to this Regulation and of drawings, giving the particulars referred to in paragraphs 2.2.2, 2.2.3 and 2.2.4 above (supplied by the applicant for approval) in a format not exceeding A 4 (210 × 297 mm) or folded to that format and on an appropriate scale.
- 3.4. There shall be affixed, conspicuously and in a readily accessible place specified on the approval form, to every vehicle conforming to a vehicle type approved under this Regulation, an international approval mark consisting of:
- 3.4.1. a circle surrounding the letter 'E' followed by the distinguishing number of the country which has granted approval <sup>(2)</sup>;
- 3.4.2. the number of this Regulation, followed 'RI', if the vehicle is approved pursuant part I of the Regulation, or by 'RII' if the vehicle is approved pursuant parts I and II of the Regulation, a dash and the approval number to the right of the circle prescribed in paragraph 3.4.1.
- 3.5. If the vehicle conforms to a vehicle type approved, under one or more other Regulations annexed to the Agreement, in the country which has granted approval under this Regulation, the symbol prescribed in paragraph 3.4.1 need not be repeated; in such a case the additional numbers, approval numbers and symbols of all the Regulations under which approval has been granted in the country which has granted approval under this Regulation shall be placed in vertical columns to the right of the symbol prescribed in paragraph 3.4.1.
- 3.6. The approval mark shall be clearly legible and indelible.
- 3.7. The approval mark shall be placed close to or on the vehicle data plate affixed by the manufacturer.
- 3.8. Annex II to this Regulation gives examples of arrangements of the approval mark.

<sup>(2)</sup> 1 for Germany, 2 for France, 3 for Italy, 4 for the Netherlands, 5 for Sweden, 6 for Belgium, 7 for Hungary, 8 for the Czech Republic, 9 for Spain, 10 for Serbia and Montenegro, 11 for the United Kingdom, 12 for Austria, 13 for Luxembourg, 14 for Switzerland, 15 (vacant), 16 for Norway, 17 for Finland, 18 for Denmark, 19 for Romania, 20 for Poland, 21 for Portugal, 22 for the Russian Federation, 23 for Greece, 24 for Ireland, 25 for Croatia, 26 for Slovenia, 27 for Slovakia, 28 for Belarus, 29 for Estonia, 30 (vacant), 31 for Bosnia and Herzegovina, 32 for Latvia, 33 (vacant), 34 for Bulgaria, 35 (vacant), 36 for Lithuania, 37 for Turkey, 38 (vacant), 39 for Azerbaijan, 40 for The former Yugoslav Republic of Macedonia, 41 (vacant), 42 for the European Community (Approvals are granted by its Member States using their respective ECE symbol), 43 for Japan, 44 (vacant), 45 for Australia, 46 for Ukraine, 47 for South Africa and 48 for New Zealand. Subsequent numbers shall be assigned to other countries in the chronological order in which they ratify or accede to the Agreement Concerning the Adoption of Uniform Technical Prescriptions for Wheeled Vehicles, Equipment and Parts which can be Fitted and/or be Used on Wheeled Vehicles and the Conditions for Reciprocal Recognition of Approvals Granted on the Basis of these Prescriptions, and the numbers thus assigned shall be communicated by the Secretary-General of the United Nations to the Contracting Parties to the Agreement.

## PART I — APPROVAL OF VEHICLE WITH REGARDS TO ITS FUEL TANKS

## 4. DEFINITIONS

For the purposes of this Part of the Regulation:

- 4.1. 'approval of a vehicle' means the approval of a vehicle type with regard to the liquid fuel tanks;
- 4.2. 'vehicle type' means vehicles which do not differ in such essential respects as:
  - 4.2.1. the structure, shape, dimensions and materials (metal/plastic) of the tank(s);
  - 4.2.2. in vehicles of category M1 <sup>(1)</sup> the position of the tank(s) in the vehicle in so far as it has a negative effect on the requirements of paragraph 5.10;
- 4.3. 'passenger compartment' means the space for occupant accommodation bounded by the roof, floor, side walls, doors, outside glazing, front bulkhead, and the plane of the rear compartment bulkhead or the plane of the rear seat back support;
- 4.4. 'tank' means the tank(s) designed to contain the liquid fuel, as defined in paragraph 4.6, used primarily for the propulsion of the vehicle excluding its accessories (filler pipe, if it is a separate element, filler hole, cap, gauge, connections to the engine or to compensate interior excess pressure, etc.);
- 4.5. 'capacity of the fuel tank' means the fuel tank capacity as specified by the manufacturer; and
- 4.6. 'liquid fuel' means a fuel which is liquid in normal conditions of temperature and pressure.

## 5. REQUIREMENTS FOR LIQUID FUEL TANKS

- 5.1. Tanks must be made so as to be corrosion-resistant.
- 5.2. Tanks must satisfy, when equipped with all accessories, which are normally attached to them, the leakage tests carried out according to paragraph 6.1 at a relative internal pressure equal to double the working overpressure, but in any event not less than an overpressure of 0,3 bar.

Tanks for vehicles made of a plastic material are considered as meeting this requirement if they have passed the test described in Annex V, paragraph 2.
- 5.3. Any excess pressure or any pressure exceeding the working pressure must be compensated automatically by suitable devices (vents, safety valves, etc.).
- 5.4. The vents must be designed in such a way as to prevent any fire risk. In particular, any fuel, which may leak when the tank(s) is (are) being filled must not be able to fall on the exhaust system. It shall be channelled to the ground.
- 5.5. The tank(s) must not be situated in, or form, a surface (floor, wall, bulkhead) of the passenger compartment or other compartment integral with it.

- 5.6. A partition must be provided to separate the occupant compartment from the tank(s). The partition may contain apertures (e.g. to accommodate cables) provided they are so arranged that fuel cannot flow freely from the tank(s) into the occupant compartment or other compartment integral with it during normal conditions of use.
- 5.7. Every tank must be securely fixed and so placed as to ensure that any fuel leaking from the tank or its accessories will escape to the ground and not into the occupant compartment during normal conditions of use.
- 5.8. The filler hole must not be situated in the occupant compartment, in the luggage compartment or in the engine compartment.
- 5.9. The fuel must not escape through the tank cap or through the devices provided to compensate excess pressure during the foreseeable course of operation of the vehicle. In the case of overturning of the vehicle, a drip may be tolerated provided that it does not exceed 30 g/min; this requirement must be verified during the test prescribed in paragraph 6.2.
- 5.9.1. The fuel filler cap must be fixed to the filler pipe.
- 5.9.1.1. The requirements of paragraph 5.9.1 will be deemed to be satisfied if provision is made to prevent excess evaporative emissions and fuel spillage caused by a missing fuel filler cap;
- This may be achieved using one of the following:
- 5.9.1.1.1. an automatically opening and closing, non-removable fuel filler cap;
- 5.9.1.1.2. design features which avoid excess evaporative emissions and fuel spillage in the case of a missing fuel filler cap;
- 5.9.1.1.3. any other provision which has the same effect. Examples may include, but are not limited to, a tether filler cap, a chained filler cap or one utilising the same locking key for the filler cap and for the vehicle's ignition. In this case, the key shall be removable from the filler cap only in the locked condition. However, the use of tethered or chained filler cap by itself is not sufficient for vehicles other than those of categories M1 and N1.
- 5.9.2. The seal between the cap and the filler pipe must be retained securely in place. The cap must latch securely in place against the seal and filler pipe when closed.
- 5.10. Tanks must be installed in such a way as to be protected from the consequences of a collision to the front or the rear of the vehicle; there shall be no protruding parts, sharp edges, etc. near the tank.
- 5.11. The fuel tank and its accessory parts shall be designed and installed in the vehicle in such a way that any ignition hazard due to static electricity shall be avoided. If necessary, measure(s) for charge dissipation shall be provided. The manufacturer shall demonstrate to the technical service the measure(s) which guarantee the fulfilling of these requirements.
- 5.12. The fuel tank(s) shall be made of a fire-resistant metallic material. It (they) may be made of a plastics material provided the requirements of annex V are complied with.

## 6. TESTS OF LIQUID FUEL TANKS

### 6.1. Hydraulic test

The tank must be subjected to a hydraulic internal pressure test which must be carried out on an isolated unit complete with all its accessories. The tank must be completely filled with a non-flammable liquid (water, for example). After all communication with the outside has been cut off, the pressure must be gradually increased, through the pipe connection through which fuel is fed to the engine, to a relative internal pressure equal to double the working pressure used and in any case to not less than an excess pressure of 0,3 bar, which must be maintained for one minute. During this time the tank shell must not crack or leak; however, it may be permanently deformed.

### 6.2. Overturn test

6.2.1. The tank and all its accessories must be mounted on to a test fixture in a manner corresponding to the mode of installation on the vehicle for which the tank is intended: this also applies to systems for the compensation of the interior excess pressure.

6.2.2. The test fixture shall rotate about an axis lying parallel to the longitudinal vehicle axis.

6.2.3. The test will be carried out with the tank filled to 90 per cent of its capacity and also 30 per cent of its capacity with a non-flammable liquid having a density and a viscosity close to those of the fuel normally used (water may be accepted).

6.2.4. The tank must be turned from its installed position 90° to the right. The tank must remain in this position for at least five minutes. The tank must then be turned 90° further in the same direction. The tank must be held in this position, in which it is completely inverted, for at least another five minutes. The tank must be rotated back to its normal position. Testing liquid that has not flowed back from the venting system into the tank must be drained and replenished if necessary. The tank must be rotated 90° in the opposite direction and left for at least five minutes in this position.

The tank must be rotated 90° further in the same direction. This completely inverted position must be maintained for at least five minutes. Afterwards the tank must be rotated back to its normal position.

The rotation rate for each successive increment of 90° shall take place in any time interval from 1 to 3 minutes.

## PART II — APPROVAL OF VEHICLE WITH REGARD TO THE PREVENTION OF FIRE RISKS IN THE EVENT OF COLLISION

### 7. DEFINITIONS

For the purposes of this Part of the Regulation:

7.1. 'approval of a vehicle' means the approval of a vehicle type with regard to the prevention of fire risks;

7.2. 'vehicle type' means vehicles which do not differ in such essential respects as:

7.2.1. the structure, shape, dimensions and materials (metal/plastic) of the tank(s);

7.2.2. in vehicles of category M1 <sup>(1)</sup> the position of the tank(s) in the vehicle in so far as it has a negative effect on the requirements of paragraph 5.10;

- 7.2.3. the characteristics and siting of the fuel feed system (pump, filters, etc.); and
- 7.2.4. the characteristics and siting of the electrical installation in so far as they have an effect on the results of the collision tests prescribed in this Regulation;
- 7.3. 'transverse plane' means the vertical transverse plane perpendicular to the median longitudinal plane of the vehicle;
- 7.4. 'unladen mass' means the mass of the vehicle in running order, unoccupied and unladen but complete with fuel, coolant, lubricants, tools and a spare wheel (if provided as standard equipment by the vehicle manufacturer).
8. REQUIREMENTS FOR INSTALLATION OF AN APPROVED LIQUID FUEL TANK
- 8.1. Fuel installation
- 8.1.1. the tanks for liquid fuel shall be approved according to Part I of this Regulation.
- 8.1.2. The components of the fuel installation shall be adequately protected by parts of the frame or bodywork against contact with possible obstacles on the ground. Such protection shall not be required if the components beneath the vehicle are further from the ground than the part of the frame or bodywork in front of them.
- 8.1.3. The pipes and all other parts of the fuel installation shall be accommodated on the vehicle at sites protected to the fullest possible extent. Twisting and bending movements, and vibrations of the vehicle's structure or drive unit, shall not subject the components of the fuel installation to friction, compression or any other abnormal stress.
- 8.1.4. The connections of pliable or flexible pipes with rigid parts of components of the fuel installation shall be so designed and constructed as to remain leak-proof under the various conditions of use of the vehicle, despite twisting and bending movements and despite vibrations of the vehicle's structure or drive unit.
- 8.1.5. If the filler hole is situated on the side of the vehicle, the filler cap shall not, when closed, project beyond the adjacent surfaces of the bodywork.
- 8.2. Electrical installation
- 8.2.1. Electric wires other than wires accommodated in hollow components shall be attached to the vehicle's structure or walls or partitions near which they lead. The points at which they pass through walls or partitions shall be satisfactorily protected to prevent cutting of the insulation.
- 8.2.2. The electrical installation shall be so designed, constructed and fitted that its components are able to resist the corrosion phenomena to which they are exposed.
9. TESTS ON THE VEHICLE
- In the frontal-impact test against a barrier carried out by the procedure specified in Annex III to this Regulation, in the lateral impact test performed according to the procedure described in Annex IV of Regulation No 95, 01 series of amendments, and in the rear-end impact test carried out by the procedure specified in Annex IV hereto,
- 9.1. no more than a slight leakage of liquid in the fuel installation shall occur on collision;

- 9.2. if there is continuous leakage in the fuel installation after the collision, the rate-of leakage must not exceed 30 g/min; if the liquid from the fuel installation mixes with liquids from the other systems, and if the several liquids cannot be easily separated and identified, the continuous leakage shall be evaluated from all the fluids collected;
- 9.3. no fire maintained by the fuel shall occur.
- 9.4. During and after the impacts described in paragraph 9 above, the battery must be kept in position by its securing device.
- 9.5. At the request of the manufacturer, the frontal collision test set out in Annex III of this Regulation can be replaced by the test procedure described in Annex III of Regulation No 94, 01 series of amendments.
10. MODIFICATIONS OF THE VEHICLE TYPE
- 10.1. Every modification of the vehicle type shall be notified to the administrative department which approved the vehicle type. The department may then either:
- 10.1.1. consider that the modifications made are unlikely to have appreciable adverse effects, and that in any case the vehicle still meets the requirements; or
- 10.1.2. require a further test report from the technical service responsible for conducting the tests.
- 10.2. Without prejudice to the provisions of paragraph 10.1 above, a variant of the vehicle whose unladen mass does not differ by more than  $\pm 20$  per cent from that of the approval-tested vehicle shall not be regarded as a modification of the vehicle type.
- 10.3. Notice of confirmation of approval or of refusal of approval, specifying the modifications shall be communicated by the procedure specified in paragraph 3.3 above to the Parties to the Agreement which apply this Regulation.
11. CONFORMITY OF PRODUCTION
- The Conformity of Production procedures shall comply with those set out in the Agreement, Appendix 2 (E/ECE/324-E/ECE/TRANS/505/Rev.2), with the following requirements:
- 11.1. Every vehicle bearing an approval mark as prescribed under this Regulation shall conform to the vehicle type approved and satisfy the requirements of Part I and/or Part II above.
- 11.2. In order to verify conformity as prescribed in paragraph 11.1 above, a sufficient number of serially-produced vehicles bearing the approval mark required by this Regulation shall be subjected to random checks.
- 11.3. As a general rule, the conformity of the vehicle with the approved type shall be checked on the basis of the description given in the approval form and its Annexes. However, the vehicle shall if necessary be subjected to the checks prescribed in paragraph 6 above.
12. PENALTIES FOR NON-CONFORMITY OF PRODUCTION
- 12.1. The approval granted in respect of a vehicle type pursuant to this Regulation may be withdrawn if the requirement laid down in paragraph 11.1 above is not complied with or if the vehicle has failed to pass the checks prescribe in paragraph 9 above.



12.2. If a Party to the Agreement which applies this Regulation withdraws an approval it has previously granted, it shall forthwith notify the other Parties to the Agreement which apply this Regulation thereof by means of a copy of the communication form conforming to the model in Annexes I or II to this Regulation.

13. TRANSITIONAL PROVISIONS

13.1. As from the official date of entry into force of the 02 series of amendments, no Contracting Party applying this Regulation shall refuse to grant ECE approval under this Regulation as amended by the 02 series of amendments.

13.2. As from 12 months after the date of entry into force of the 02 series of amendments, Contracting Parties applying this Regulation shall grant ECE approvals only if vehicle type to be approved meets the requirements of this Regulation as amended by the 02 series of amendments.

13.3. Until 12 months after the date of entry into force of the 02 series of amendments to this Regulation, no Contracting Party applying this Regulation shall refuse national type approval of a vehicle type approved to the preceding series of amendments to this Regulation.

13.4. Starting 24 months after the entry into force of the 02 series of amendments to this Regulation, Contracting Parties applying this Regulation may refuse first national registration (first entry into service) of a vehicle which does not meet the requirements of the 02 series of amendments to this Regulation.

14. NAMES AND ADDRESSES OF TECHNICAL SERVICES CONDUCTING APPROVAL TESTS, AND OF ADMINISTRATIVE DEPARTMENTS

The Parties to the Agreement which apply this Regulation shall communicate to the Secretariat of the United Nations the names and addresses of the technical services conducting approval tests and of the administrative departments which grant approval and to which forms certifying approval or refusal or withdrawal of approval, issued in other countries, are to be sent.

---

ANNEX I

COMMUNICATION

(Maximum format: A4 (210 × 297 mm))



issued by: Name of administration:
.....
.....
.....

concerning: (2) APPROVAL GRANTED
APPROVAL EXTENDED
APPROVAL REFUSED
APPROVAL WITHDRAWN
PRODUCTION DEFINITELY DISCONTINUED

of a vehicle type with regard: to the tank for liquid fuel
to the prevention of fire risks in the event of frontal/lateral/rear (2) collision

pursuant to Regulation No 34.

Approval No: ..... Extension No: .....

- 1. Trade name or mark of the power-driven vehicle: .....
2. Vehicle type: .....
3. Manufacturer's name and address: .....
4. If applicable, name and address of manufacturer's representative: .....
5. Kind of engine: positive-ignition/diesel (2)
6. Site of engine: front/rear/centre (2)
7. Brief description of fuel tank and fuel: .....
7.1. Characteristics and site of fuel tank: .....
7.2. For fuel tanks made of a plastic material, state material and trade name or mark: .....
7.3. Characteristics of fuel installation (site, connections, etc.): .....
8. Description of electrical installation (site attachment, protection, etc.): .....
9. Description of the impact tests:
Frontal (Type/Approval or report number): .....
Side (Type/Approval or report number): .....
Rear (Type/Approval or report number): .....

(1) Distinguishing number of the country which has granted/extended/refused/withdrawn/ the approval (see approval provisions in the Regulation).
(2) Strike out what does not apply.

10. Vehicle submitted for approval on: .....
11. Technical service responsible for conducting approval tests: .....
12. Date of report issued by that service: .....
13. Number of report issued by that service: .....
14. Approval granted/extended/refused/withdrawn <sup>(1)</sup>
15. Position of approval mark on the vehicle: .....
16. Place: .....
17. Date: .....  
.....
18. Signature: .....
19. The following documents, bearing the approval number shown above, are annexed to this communication: .....  
  
drawings and layout diagrams of the fuel tank, the fuel installation, the electrical installation, and other components of importance for the purposes of this Regulation.

---

---

<sup>(1)</sup> Strike out what does not apply.

## ANNEX II

## ARRANGEMENTS OF APPROVAL MARKS

## MODEL A

(see paragraph 3.4. of this Regulation)

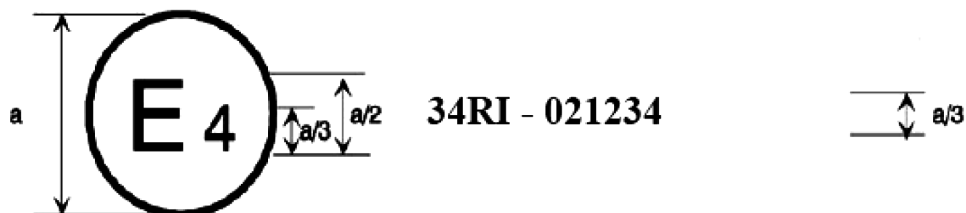

a = 8 mm min.

The above approval mark affixed to a vehicle shows that the type concerned was approved in the Netherlands (E4) pursuant to Part I of Regulation No 34 under approval No 021234. The first two digits (02) of the approval number indicate that the approval was granted in accordance with the requirements of Regulation No 34 as amended by the 02 series of amendments.

## MODEL B

(See paragraph 3.5. of this Regulation)

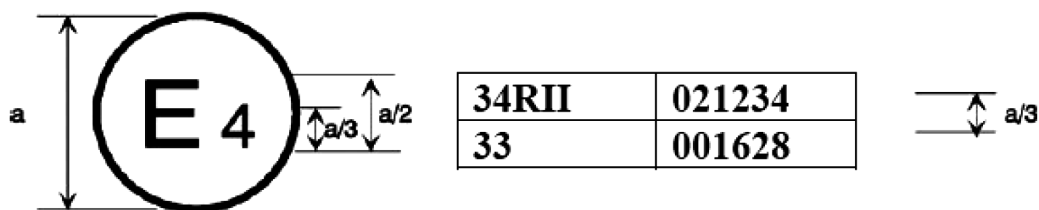

a = 8 mm min.

The above approval mark affixed to a vehicle shows that the type concerned was approved in the Netherlands (E4) pursuant to Regulations Nos 34 Parts I and II and 33<sup>(1)</sup>. The approval numbers indicated that, at the date when the respective approvals were given, Regulation No 34 included the 02 series of amendments and Regulation No 33 was still in its original form.

<sup>(1)</sup> The second number is given merely as an example.

## ANNEX III

**Frontal-collision test against a barrier**

## 1. PURPOSE AND SCOPE

The purpose of this test is to simulate the conditions of frontal collision against a fixed obstacle or by another vehicle approaching from the opposite direction.

## 2. INSTALLATIONS, PROCEDURES AND MEASURING INSTRUMENTS

## 2.1. Testing ground

The test area shall be large enough to accommodate the run-up track, barrier and technical installations necessary for the test. The last part of the track, for at least 5 m before the barrier, must be horizontal, flat and smooth.

## 2.2. Barrier

The barrier consists of a block of reinforced concrete not less than 3 m wide in front and not less than 1.5 m high. The barrier must be of such thickness that it weighs at least 70 tonnes. The front face must be vertical, perpendicular to the axis of the run-up track, and covered with plywood boards 2 cm thick in good condition. The barrier shall be either anchored in the ground or placed on the ground with, if necessary, additional arresting devices to limit its displacement. A barrier with different characteristics, but giving results at least equally conclusive, may likewise be used.

## 2.3. Propulsion of vehicle

At the moment of collision, the vehicle must no longer be subject to the action of any additional steering or propelling device. It must reach the obstacle on a course perpendicular to the collision wall; the maximum lateral misalignment tolerated between the vertical median line of the front of the vehicle and the vertical median line of the collision wall is  $\pm 30$  cm.

## 2.4. State of vehicle

2.4.1. The vehicle under test shall either be fitted with all the normal components and equipment included in its unladen kerb weight or be in such condition as to fulfil this requirement so far as the components and equipment affecting fire risks are concerned.

2.4.2. If the vehicle is driven by external means, the fuel installation must be filled to at least 90 per cent of its capacity either with fuel or with a non-inflammable liquid having a density and a viscosity close to those of the fuel normally used. All other systems (brake fluid header tanks, radiator, etc.) may be empty.

2.4.3. If the vehicle is driven by its own engine, the fuel tank must be at least 90 per cent full. All other liquid-holding tanks may be filled to capacity.

2.4.4. If the manufacturer so requests, the technical service responsible for conducting the tests may allow the same vehicle as is used for tests prescribed by other Regulations (including tests capable of affecting its structure) to be used also for the tests prescribed by this Regulation.

## 2.5. Velocity on collision

The velocity on collision must be between 48.3 km/h and 53.1 km/h. However, if the test has been carried out at a higher collision velocity and the vehicle has satisfied the conditions prescribed, the test shall be considered satisfactory.

## 2.6. Measuring instruments

The instrument used to record the speed referred to in paragraph 2.5. above shall be accurate to within one per cent.

## 3. EQUIVALENT TEST METHODS

3.1. Equivalent test methods are permitted provided that the conditions referred to in this Regulation can be observed either entirely by means of the substitute test or by calculation from the results of the substitute test.

3.2. If a method other than that described in paragraph 2. above is used its equivalence must be demonstrated.

## ANNEX IV

**Procedure for rear-end collision test**

1. PURPOSE AND SCOPE
  - 1.1. The purpose of the test is to simulate the conditions of rear-end collision by another vehicle in motion.
2. INSTALLATIONS, PROCEDURES AND MEASURES INSTRUMENTS
  - 2.1. Testing ground

The test area shall be large enough to accommodate the impactor (striker) propulsion system and to permit after-collision displacement of the vehicle struck and installation of the test equipment. The part in which vehicle collision and displacement occur shall be horizontal, flat and smooth and have a coefficient of friction of not less than 0.5.
  - 2.2. Impactor (striker)
    - 2.2.1. The impactor shall be of steel and of rigid construction.
    - 2.2.2. The impacting surface shall be flat, not less than 2 500 mm wide, and 800 mm high, and its edges shall be rounded to a radius of curvature of between 40 and 50 mm. It shall be clad with a layer of plywood 20 mm thick.
    - 2.2.3. At the moment of collision the following requirements shall be met:
      - 2.2.3.1. the impacting surface shall be vertical and perpendicular to the median longitudinal plane of the vehicle struck;
      - 2.2.3.2. the direction of movement of the impactor shall be substantially horizontal and parallel to the median longitudinal plane of the vehicle struck;
      - 2.2.3.3. the maximum lateral deviation tolerated between the median vertical line of the surface of the impactor and the median longitudinal plane of the vehicle struck shall be 300 mm. In addition, the impacting surface shall extend over the entire width of the vehicle struck;
      - 2.2.3.4. the ground clearance of the lower edge of the impacting surface shall be  $175 \pm 25$  mm.
  - 2.3. Propulsion of the impactor

The impactor may either be secured to a carriage (moving barrier) or form part of a pendulum.
  - 2.4. Special provisions applicable where a moving barrier is used
    - 2.4.1. If the impactor is secured to a carriage (moving barrier) by a restraining element, the latter must be rigid and be incapable of being deformed by the collision; the carriage shall at the moment of collision be capable of moving freely and no longer be subject to the action of the propelling device.
    - 2.4.2. The velocity of collision shall be between 35 and 38 km/h.
    - 2.4.3. The aggregate weight (mass) of carriage and impactor shall be  $1\,100 \pm 20$  kg.
  - 2.5. Special provisions applicable where a pendulum is used
    - 2.5.1. The distance between the centre of the impacting face and the axis of rotation of the pendulum shall be not less than 5 m.
    - 2.5.2. The impactor shall be freely suspended by rigid arms rigidly secured to it. The pendulum so constituted shall be substantially incapable of being deformed by the collision.
    - 2.5.3. Arresting gear shall be incorporated in the pendulum to prevent any secondary collision by the impactor on the test vehicle.
    - 2.5.4. At the moment of collision the velocity of the centre of percussion of the pendulum should be between 35 and 38 km/h.

- 2.5.5. The reduced mass 'm<sub>r</sub>' at the centre of percussion of the pendulum is defined as a function of the total mass 'm', of the distance 'a' <sup>(1)</sup> between the centre of percussion and the axis of rotation, and of the distance 'l' between the centre of gravity and the axis of rotation, by the following equation:

$$m_r = m (l/a)$$

- 2.5.6. The reduced mass m<sub>r</sub> shall be 1 100 ± 20 kg.

- 2.6. General provisions relating to the mass and velocity of the impactor

If the test has been conducted at a collision velocity higher than those prescribed in paragraphs 2.4.2 and 2.5.4 and/or with a mass greater than those prescribed in paragraphs 2.4.3 and 2.5.6, and the vehicle has met the requirements prescribed, the test shall be considered satisfactory.

- 2.7. State of vehicle under test

- 2.7.1. The vehicle under test shall either be fitted with all the normal components and equipment included in its unladen kerb weight or be in such condition as to fulfil this requirement so far as the components and equipment affecting fire risks are concerned.

- 2.7.2. The fuel tank must be filled to at least 90 per cent of its capacity either with fuel or with a non-inflammable liquid having a density and a viscosity close to those of the fuel normally used. All other systems (brake fluid header tanks, radiator, etc.) may be empty.

- 2.7.3. A gear may be engaged and the brakes may be applied.

- 2.7.4. If the manufacturer so requests, the following derogation shall be permitted:

- 2.7.4.1. the technical service responsible for conducting the tests may allow the same vehicle as is used for tests prescribed by other Regulations (including tests capable of affecting its structure) to be used also for the tests prescribed by this Regulation; and

- 2.7.4.2. the vehicle may be weighted to an extent not exceeding 10 per cent of its unladen kerb weight with additional weights rigidly secured to the structure in such a way as not to affect the behaviour of the structure of the passenger compartment during the test.

- 2.8. Measuring instruments

The instruments used to record the speed referred to in paragraphs 2.4.2 and 2.5.4 above shall be accurate to within one per cent.

3. EQUIVALENT TEST METHODS

- 3.1. Equivalent test methods are permitted provided that the conditions referred to in this Regulation can be observed either entirely by means of the substitute test or by calculation from the results of the substitute test.

- 3.2. If a method other than that described in paragraph 2 above is used, its equivalence must be demonstrated.

---

<sup>(1)</sup> It is recalled that the distance 'a' is equal to the length of the synchronous pendulum under consideration.

## ANNEX V

**TESTING OF FUEL TANKS MADE OF A PLASTIC MATERIAL**

## 1. COLLISION RESISTANCE

- 1.1. The tank must be filled to its capacity with a water-glycol mixture or with another liquid having a low freezing point, which does not change the properties of the tank material, and must then be subjected to a perforation test.
- 1.2. During this test the tank temperature must be  $233\text{ K} \pm 2\text{ K}$  ( $-40\text{ °C} \pm 2\text{ °C}$ ).
- 1.3. A pendulum collision testing fixture must be used for the test. The collision body must be of steel and have the shape of a pyramid with equilateral-triangle faces and a square base, the summit and the edges being rounded to a radius of 3 mm. The centre of percussion of the pendulum must coincide with the centre of gravity of the pyramid; its distance from the axis of rotation of the pendulum must be 1 m. The total mass of the pendulum must be 15 kg. The energy of the pendulum at the moment of collision must be not less than 30 Nm and as close to that value as possible.
- 1.4. The tests must be made on the points of the tank which are regarded as vulnerable to frontal or rear collisions. The points regarded as vulnerable are those which are most exposed or weakest having regard to the shape of the tank or the way in which it is installed on the vehicle. The points selected by the laboratories must be indicated in the test report.
- 1.5. During the test, the tank must be held in position by the fittings on the side or sides opposite the side of collision. No leak must result from the test.
- 1.6. At the choice of the manufacturer, all the impact tests may be carried out on one tank or each may be carried out on a different tank.

## 2. MECHANICAL STRENGTH

The tank must be tested under the conditions prescribed in paragraph 6.1 of this Regulation for leaks and for rigidity of shape. The tank and all its accessories must be mounted onto a test fixture in a manner corresponding to the mode of installation on the vehicle for which the tank is intended or mounted in the vehicle itself or mounted in a test fixture made by a vehicle section. On request of the manufacturer and with the agreement of the technical service the tank may be tested without using any test fixture. Water at  $326\text{ K}$  ( $53\text{ °C}$ ) must be used as the testing fluid and must fill the tank to its capacity. The tank must be subjected to a relative internal pressure equal to double the working pressure and in any case to not less than 30 kPa at a temperature of  $326\text{ K} \pm 2\text{ K}$  ( $53\text{ °C} \pm 2\text{ °C}$ ) for a period of five hours. During the test, the tank and its accessories must not crack or leak; however, it may be permanently deformed.

## 3. FUEL PERMEABILITY

- 3.1. The fuel used for the permeability test must be either the reference fuel specified in Regulation No 83, Annex IX or a commercial premium-grade fuel. If the tank is only designed for installation on vehicles with a compression-ignition engine, the tank shall be filled with diesel fuel.
- 3.2. Prior to the test, the tank must be filled to 50 per cent of its capacity with testing fuel and stored, without being sealed, at an ambient temperature of  $313\text{ K} \pm 2\text{ K}$  ( $40\text{ °C} \pm 2\text{ °C}$ ) until the weight loss per unit time becomes constant, but for not more than four weeks (preliminary storage time).
- 3.3. The tank must then be emptied and refilled to 50 per cent of its capacity with test fuel, after which it must be hermetically sealed and be stored at a temperature of  $313\text{ K} \pm 2\text{ K}$  ( $40\text{ °C} \pm 2\text{ °C}$ ). The pressure must be adjusted when the contents of the tank have reached the testing temperature. During the ensuing test period of eight weeks, the loss of weight due to diffusion during the test period shall be determined. The maximum permissible average loss of fuel is 20 g per 24 hours of testing time.
- 3.4. If the loss due to diffusion exceeds the value indicated in paragraph 3.3, the test described there must be carried out again, on the same tank, to determine the loss by diffusion at  $296\text{ K} \pm 2\text{ K}$  ( $23\text{ °C} \pm 2\text{ °C}$ ) but under the same conditions otherwise. The loss so measured shall not exceed 10 g per 24 hours.



#### 4. RESISTANCE TO FUEL

After the test referred to in paragraph 3, the tank must still meet the requirements set out in paragraphs 1 and 2.

#### 5. RESISTANCE TO FIRE

The tank must be subjected to the following tests.

5.1. For two minutes, the tank, fixed as on the vehicle, must be exposed to flame. There must be no leakage of liquid fuel from the tank.

5.2. Three tests must be made on different tanks filled with fuel as follows:

5.2.1. If the tank is designed for installation on vehicles equipped with either a positive ignition engine or a compression-ignition engine, three tests must be carried out with tanks filled with premium-grade gasoline;

5.2.2. If the tank is only designed for installation on vehicles equipped with a compression-ignition engine, three tests must be carried out with tanks filled with diesel fuel;

5.2.3. For each test the tank and its accessories must be installed in a testing fixture simulating actual installation conditions as far as possible. The method whereby the tank is fixed in the fixture must correspond to the relevant specifications for the vehicle. Vehicle parts which protect the tank and its accessories against exposure to flame or which affect the course of the fire in any way, as well as specified components installed on the tank and plugs must be taken into consideration. All openings must be closed during the test, but venting systems must remain operative. Immediately prior to the test the tank must be filled with the specified fuel to 50 per cent of its capacity.

5.3. The flame to which the tank is exposed must be obtained by burning commercial fuel for positive-ignition engines (hereafter called fuel) in a pan. The quantity of fuel poured into the pan shall be sufficient to permit the flame, under free-burning conditions, to burn for the whole test procedure.

5.4. The pan dimensions must be chosen so as to ensure that the sides of the fuel tank are exposed to the flame. The pan must therefore exceed the horizontal projection of the tank by at least 20 cm, but not more than 50 cm. The sidewalls of the pan must not project more than 8 cm above the level of the fuel at the start of the test.

5.5. The pan filled with fuel must be placed under the tank in such a way that the distance between the level of the fuel in the pan and the tank bottom corresponds to the design height of the tank above the road surface at the unladen mass (see paragraph 7.4). Either the pan, or the testing fixture, or both, must be freely movable.

5.6. During phase C of the test, the pan must be covered by a screen placed  $3 \text{ cm} \pm 1 \text{ cm}$  above the fuel level. The screen must be made of a refractory material, as prescribed in Appendix 2. There must be no gap between the bricks and they must be supported over the fuel pan in such a manner that the holes in the bricks are not obstructed. The length and width of the frame must be 2 cm to 4 cm smaller than the interior dimensions of the pan so that a gap of 1 cm to 2 cm exists between the frame and the wall of the pan to allow ventilation.

5.7. When the tests are carried out in the open air, sufficient wind protection must be provided and the wind velocity at fuel-pan level must not exceed 2,5 km/h. Before the test the screen must be heated to  $308 \text{ K} \pm 5 \text{ K}$  ( $35 \text{ °C} \pm 5 \text{ °C}$ ). The firebricks may be wetted in order to guarantee the same test conditions for each successive test.

5.8. The test must comprise four phases (see Appendix 1).

5.8.1. Phase A: Pre-heating (Figure 1)

The fuel in the pan must be ignited at a distance of at least 3 m from the tank being tested. After 60 seconds pre-heating, the pan must be placed under the tank.

5.8.2. Phase B: Direct exposure to flame (Figure 2)

For 60 seconds the tank must be exposed to the flame from the freely burning fuel.

5.8.3. Phase C: Indirect exposure to flame (Figure 3)

As soon as phase B has been completed, the screen must be placed between the burning pan and the tank. The tank must be exposed to this reduced flame for a further 60 seconds.

5.8.4. Phase D: End of test (Figure 4)

The burning pan covered with the screen must be moved back to its original position (phase A). If, at the end of the test, the tank is burning, the fire must be extinguished forthwith.

5.9. The results of the test shall be considered satisfactory if no liquid fuel is leaking from the tank.

6. RESISTANCE TO HIGH TEMPERATURE

6.1. The fixture used for the test must match the manner of installation of the tank on the vehicle, including the way in which the tank vent works.

6.2. The tank filled to 50 per cent of its capacity with water at 293 K (20 °C) must be subjected for one hour to an ambient temperature of 368 K  $\pm$  2 K (95 °C  $\pm$  2 °C).

6.3. The results of the test shall be considered satisfactory if, after the test, the tank is not leaking or seriously deformed.

7. MARKINGS ON THE FUEL TANK

The trade name or mark must be affixed to the tank; it must be indelible and clearly legible on the tank when the latter is installed on the vehicle.

---

Appendix 1

Test of resistance to fire

Figure 1

Phase A: Pre-heating

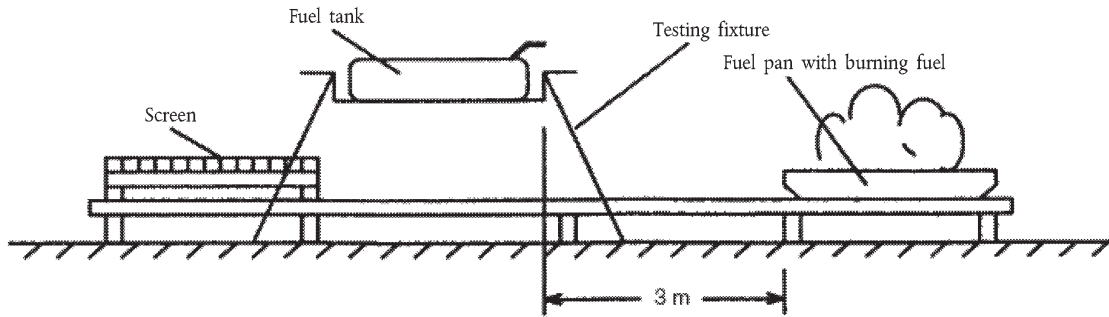

Figure 2

Phase B: Direct exposure to flame

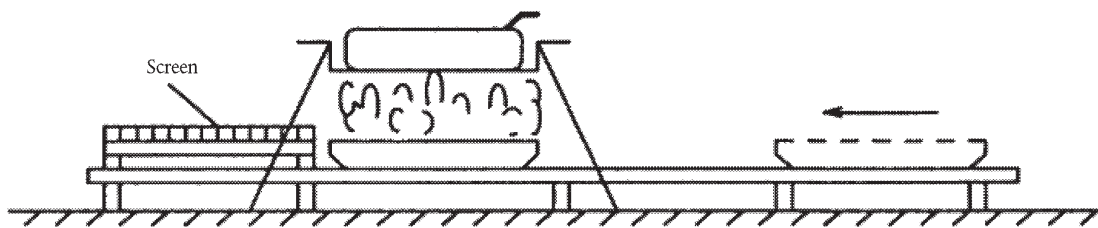

Figure 3

Phase C: Indirect exposure to the flame

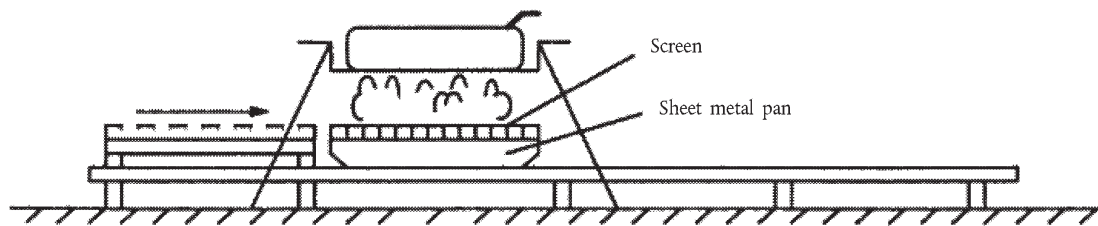
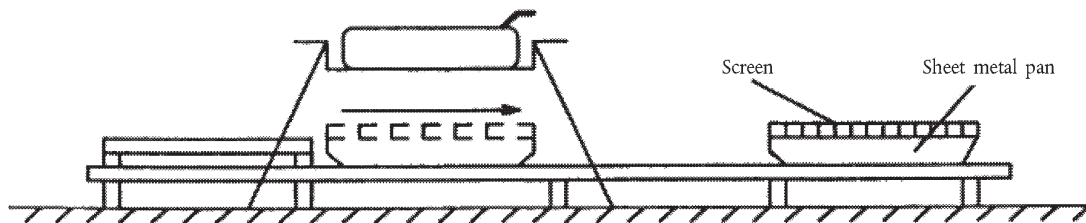

Figure 4

Phase D: End of test



## Appendix 2

## Dimensions and technical data of firebricks

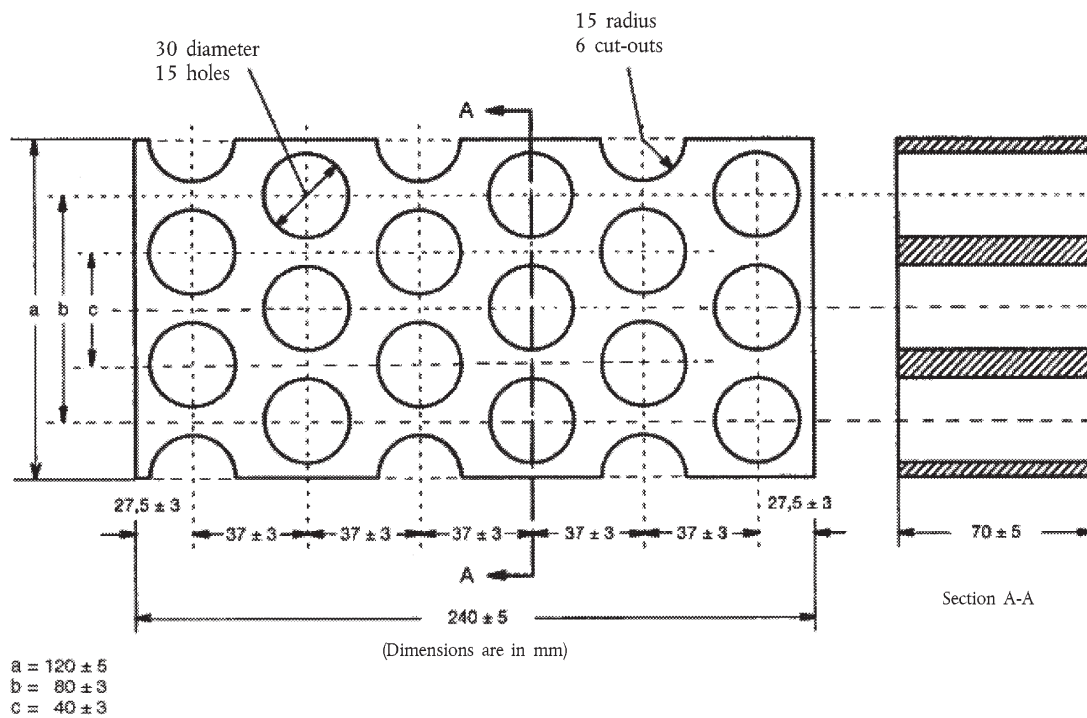

FIRE RESISTANCE (Seger-Kegel)	SK 30
AL <sub>2</sub> O <sub>3</sub> CONTENT	30-33 per cent
OPEN POROSITY (P <sub>o</sub> )	20-22 per cent vol.
DENSITY	1 900-2 000 kg/m <sup>3</sup>
EFFECTIVE HOLED AREA	44,18 per cent