

DIRECTIVES

COMMISSION DIRECTIVE 2010/19/EU

of 9 March 2010

amending, for the purposes of adaptation to technical progress in the field of spray-suppression systems of certain categories of motor vehicles and their trailers, Council Directive 91/226/EEC, and Directive 2007/46/EC of the European Parliament and of the Council

(Text with EEA relevance)

THE EUROPEAN COMMISSION,

Having regard to the Treaty on the Functioning of the European Union,

Having regard to Directive 2007/46/EC of the European Parliament and of the Council of 5 September 2007 establishing a framework for the approval of motor vehicles and their trailers, and of systems, components and separate technical units intended for such vehicles (Framework Directive) ⁽¹⁾, and in particular Article 39(2) thereof,

Whereas:

- (1) Council Directive 91/226/EEC of 27 March 1991 on the approximation of the laws of the Member States relating to the spray-suppression systems of certain categories of motor vehicles and their trailers ⁽²⁾ is one of the separate directives in the context of the EC type-approval procedure established under Directive 2007/46/EC. The provisions of Directive 2007/46/EC relating to systems, components and separate technical units for vehicles therefore apply to Directive 91/226/EEC.
- (2) In view of the mandatory application of the EC type-approval procedure to all vehicle categories covered by Directive 2007/46/EC, it is necessary to provide harmonised requirements with regard to spray

suppression for all vehicle categories covered by Directive 91/226/EEC. Furthermore, it is necessary to clarify that those requirements are not mandatory for off-road vehicles. Finally, in view of the experience gained, it is necessary to adapt Directive 91/226/EEC and, consequently, Annex IV to Directive 2007/46/EC to technical progress.

- (3) Directives 91/226/EEC and 2007/46/EC should therefore be amended accordingly.
- (4) The measures provided for in this Directive are in accordance with the opinion of the Technical Committee — Motor Vehicles,

HAS ADOPTED THIS DIRECTIVE:

Article 1

Directive 91/226/EEC shall be amended as follows:

- the list of Annexes and Annexes I, II and III are amended in accordance with Annex I to this Directive;
- the unnumbered Annex entitled 'Figures' is replaced by the text set out in Annex II to this Directive.

Article 2

Item 43 of Annex IV and Annex XI, Appendices 2 and 4 to Directive 2007/46/EC shall be replaced by the following:

'43	Spray suppression systems	Directive 91/226/EEC	L 103, 23.4.1991, p. 5					X	X	X	X	X	X	X
-----	---------------------------	----------------------	------------------------	--	--	--	--	---	---	---	---	---	---	---

⁽¹⁾ OJ L 263, 9.10.2007, p. 1.

⁽²⁾ OJ L 103, 23.4.1991, p. 5.

Article 3

1. With effect from 9 April 2011 Member States shall not, on grounds related to spray suppression, refuse to grant an EC or national type-approval to a vehicle and a component complying with the requirements laid down in Directive 91/226/EEC as amended by this Directive.
2. With effect from 9 April 2011 Member States shall, on grounds related to spray suppression, refuse to grant an EC or national type-approval to a vehicle and a component not complying with the requirements laid down in Directive 91/226/EEC as amended by this Directive.
3. When applying for EC whole vehicle type-approval under Directive 2007/46/EC, vehicle types which were granted a national or EC type-approval covering spray-suppression, shall not have to comply with the spray-suppression requirements set out in Directive 91/226/EEC.

Article 4

1. Member States shall adopt and publish, by 8 April 2011 at the latest, the laws, regulations and administrative provisions necessary to comply with this Directive. They shall forthwith communicate to the Commission the text of those provisions.

They shall apply those provisions from 9 April 2011.

When Member States adopt those provisions, they shall contain a reference to this Directive or be accompanied by such a reference on the occasion of their official publication. Member States shall determine how such reference is to be made.

2. Member States shall communicate to the Commission the text of the main provisions of national law which they adopt in the field covered by this Directive.

Article 5

This Directive shall enter into force on the 20th day following its publication in the *Official Journal of the European Union*.

Article 6

This Directive is addressed to the Member States.

Done at Brussels, 9 March 2010.

For the Commission

The President

José Manuel BARROSO

ANNEX I

1. The list of Annexes to Directive 91/226/EEC is amended as follows:

(a) the title relating to Appendix 3 of Annex II is replaced by the following:

‘Information document for EC component type-approval’;

(b) the title relating to Annex III is replaced by the following:

‘Annex III: Requirements relating to the EC type approval of a vehicle with regard to the fitting of spray suppression systems

Appendix 1: Information document for EC vehicle type-approval

Appendix 2: Model for EC vehicle type-approval certificate’;

(c) the line ‘FIGURES: (1 to 9)’ is replaced by the following:

‘Annex V: Figures 1 to 9’.

2. Annex I to Directive 91/226/EEC is amended as follows:

(a) points 9, 10 and 11 are replaced by the following:

‘9. *Retractable axle*

“Retractable axle” means an axle as defined in Annex I point 2.15 to Directive 97/27/EC.

10. *Unladen vehicle*

“Unladen vehicle” means a vehicle in running order as defined in point 2.6 of Annex I to Directive 2007/46/EC of the European Parliament and of the Council (*).

11. *Tread*

“Tread” is the part of the tyre as defined in point 2.8 of Annex II to Directive 92/23/EEC.

(*) OJ L 263, 9.10.2007, p. 1.’;

(b) the following points 13, 14 and 15 are added:

‘13. *Semitrailer towing vehicle*

“Semitrailer towing vehicle” means a towing vehicle as defined in point 2.1.1.2.2 of Annex I to Directive 97/27/EC.

14. *Technically permissible maximum laden mass*

“Technically permissible maximum laden mass” means the maximum mass of the vehicle as defined in point 2.6 of Annex I to Directive 97/27/EC.

15. *Type of vehicle*

“Type of vehicle” means, in relation to spray suppression complete, incomplete or completed vehicles, which do not differ with respect to the following aspects:

— type of spray suppression device (installed on the vehicle),

— manufacturer’s spray suppression system type designation.’

3. Annex II to Directive 91/226/EEC is amended as follows:

(a) points 2 to 3.4.3 are replaced by the following:

2. Application for EC component type-approval

2.1. The application for EC component type-approval pursuant to Article 7 of Directive 2007/46/EC of a type of spray-suppression device shall be submitted by the manufacturer.

2.2. A model for the information document is set out in Appendix 3.

2.3. The following shall be submitted to the technical service responsible for conducting the type-approval tests:

Four samples: three of which for tests and a fourth to be kept by the laboratory for any subsequent verification. The test laboratory may require further samples.

2.4. Markings

Each sample must be clearly and indelibly marked with the trade name or mark and an indication of the type and include a space that is large enough for the EC component type-approval mark.

3. Granting of EC component type-approval

3.1. If the relevant requirements are satisfied, EC type-approval pursuant to Article 10 of Directive 2007/46/EC shall be granted.

3.2. A model for the EC type-approval certificate is set out in Appendix 4.

3.3. An approval number in accordance with Annex VII to Directive 2007/46/EC shall be assigned to each type of spray-suppression device approved. The same Member State shall not assign the same number to another type of spray-suppression device.

3.4. Any spray-suppression device in conformity with a type approved pursuant to this Directive shall bear an EC component type-approval mark, so affixed as to be indelible and easily legible even when the device is fitted to the vehicle.

3.5. A symbol "A" for devices of the energy-absorption type or "S" for devices of the air/water separator type shall be added to the approval mark in accordance with point 1.3 of the Appendix of Annex VII to Directive 2007/46/EC.;

(b) Appendices 1 to 4 are replaced by the following:

Appendix 1

Tests on spray-suppression devices of the energy-absorber type

1. *Principle*

The aim of this test is to quantify the ability of a device to retain the water directed against it by a series of jets. The test assembly is intended to reproduce the conditions under which the device is to function when fitted to a vehicle as regards the volume and speed of the water thrown up from the ground by the tyre tread.

2. *Equipment*

See Figure 8 in Annex V for a description of the test assembly.

3. *Test conditions*

3.1. The tests must be carried out in a closed room with a still-air environment.

3.2. The ambient temperature and the temperature of the test pieces must be 21 (\pm 3) °C.

- 3.3. De-ionized water is to be used.
- 3.4. The test pieces must be prepared for each test by wetting.
4. *Procedure*
- 4.1. Secure a 500 (+ 0/- 5) mm wide 750 mm high sample of the equipment to be tested to the vertical plate of the testing equipment, making sure that the sample lies well within the limits of the collector, and that no obstacle is able to deflect the water, either before or after its impact.
- 4.2. Set the water flow rate at 0,675 (+/- 0,01) l/s and direct at least 90 l, at most 120 l on to the sample from a horizontal distance of 500 (+/- 2) mm (Figure 8 of Annex V).
- 4.3. Allow the water to trickle from the sample into the collector. Calculate the percentage of water collected versus the quantity of water sprayed.
- 4.4. Carry out the test five times on the sample according to points 4.2 and 4.3. Calculate the average percentage of the series of five tests.
5. *Results*
- 5.1. The average percentage calculated in point 4.4 must be 70 % or higher.
- 5.2. If within a series of five tests the highest and lowest percentages of water collected depart from the average percentage by more than 5 %, the series of five tests must be repeated.
- If within a second series of five tests the highest and lowest percentages of water recovered again depart from the average percentage by more than 5 % and if the lower value does not satisfy the requirements of point 5.1, type-approval shall be refused.
- 5.3. Test whether the vertical position of the device influences the results obtained. If it is the case, the procedure described in points 4.1 to 4.4 must be repeated in the positions giving the highest and lowest percentage of water collected; the requirements of point 5.2 remain in force.
- The mean of the individual results shall then be taken to give the average percentage. this average percentage must be 70 or higher.

Appendix 2

Test on spray-suppression devices of the air/water separator type

1. *Principle*
- This test is intended to determine the effectiveness of a porous material intended to retain the water with which it has been sprayed by means of a pressurised air/water pulveriser.
- The equipment used for the test must simulate the conditions to which the material would be submitted, with regard to the volume and speed of the water sprays produced by the tyres, if it were fitted to a vehicle.
2. *Equipment*
- See figure 9 in Annex v for a description of the test assembly.
3. *Test conditions*
- 3.1. The tests must be carried out in a closed room with a still-air environment.
- 3.2. The ambient temperature and the temperature of the test pieces must be 21 (\pm 3) °C.
- 3.3. De-ionized water must be used.

3.4. The test pieces must be prepared for each test by wetting

4. *Procedure*

4.1. Secure a 305 × 100 mm sample vertically in the test assembly, check that there is no space between the sample and the upper curved plate and that the tray is properly in position. Fill the pulveriser tank with $1 \pm 0,005$ litres of water and place this as described in the diagram.

4.2. The pulveriser must be regulated as follows:

pressure (at pulveriser): 5 bar + 10 %/– 0 %

flowrate: 1 litre/minute \pm 5 seconds

pulverisation: circular, 50 ± 5 mm in diameter at 200 ± 5 mm from the sample, nozzle $5 \pm 0,1$ mm in diameter.

4.3. Pulverise until there is no more water mist and note the time taken. Let the water flow out of the sample on to the tray for 60 seconds and measure the volume of water collected. Measure the quantity of water left in the pulveriser tank. Calculate the percentage by volume of water collected versus the volume of water pulverised.

4.4. Carry out the test five times and calculate the average percentage of the quantity collected. Check before each test that the tray, pulveriser tank and measuring vessel are dry.

5. *Results*

5.1. The average percentage calculated in point 4.4 must be 85 % or higher.

5.2. If within a series of five tests the highest and lowest percentages of water collected depart from the average percentage by more than 5 %, the series of five tests must be repeated. If within a second series of five tests the highest and lowest percentages of water recovered again depart from the average percentage by more than 5 %, and if the lower value does not satisfy the requirements of point 5.1, type-approval shall be refused.

5.3. Where the vertical position of the device influences the results obtained, the procedure described in points 4.1 to 4.4 must be repeated in the positions giving the highest and lowest percentages of water collected; the requirements of point 5.2 remain in force.

The requirement of point 5.1 remains in force in order to give the results of each test.

Appendix 3

Information document No ... relating to the EC component type-approval of spray suppression devices (Directive 91/226/EEC)

The following information, if applicable, must be supplied in triplicate and include a list of contents. Any drawings must be supplied in appropriate scale and in sufficient detail on size A4 or on a folder of A4 format. Photographs, if any, must show sufficient detail.

If the systems, components or separate technical units have electronic controls, information concerning their performance must be supplied.

0. GENERAL

0.1. Make (trade name of manufacturer):

0.2. Type:

0.5. Name and address of manufacturer:

0.7. In the case of components and separate technical units, location and method of affixing of the EC approval mark:

0.8. Address(es) of assembly plant(s):

1. DESCRIPTION OF THE DEVICE

1.1. A technical description of the spray-suppression device indicating its physical operating principle and the relevant test to which it must be subject:

1.2. The materials used:

1.3. Drawing(s) in sufficient detail and to an appropriate scale to enable this (or these) to be identified. The drawing must show the space intended for the EEC component type-approval mark:

Date

Signed

Appendix 4

MODEL

(maximum format: A4 (210 × 297 mm))

EC TYPE-APPROVAL CERTIFICATE

Stamp of type-approval authority

Communication concerning:

- EC type approval
- Extension of EC type approval
- Refusal of EC type approval
- Withdrawal of EC type approval

of a type of a vehicle/component/separate technical unit ⁽¹⁾ with regard to Directive 91/226/EEC, as last amended by Commission Directive 2010/19/EU ⁽²⁾

Type-approval number:

Reason for extension:

SECTION I

- 0.1. Make (trade name of manufacturer):
- 0.2. Type:
- 0.3. Means of identification of type if marked on the vehicle/component/separate technical unit ⁽¹⁾ ⁽³⁾
 - 0.3.1. Location of that marking:
- 0.4. Category of vehicle ⁽⁴⁾
- 0.5. Name and address of manufacturer:
- 0.7. In the case of components and separate technical units, location and method of affixing of the EC approval mark:
- 0.8. Address(es) of assembly plant(s):

SECTION II

1. Additional information (where applicable): *see Addendum*
2. Technical service responsible for carrying out the tests:
3. Date of test report:
4. Number of test report:
5. Remarks (if any): *see Addendum*
6. Place:
7. Date:
8. Signature:
9. The index to the information package lodged with the approval authority, which may be obtained on request, is attached.

⁽¹⁾ Delete where not applicable.

⁽²⁾ OJ L 72, 20.3.2010, p. 17.

⁽³⁾ If the means of identification type contains characters not relevant to describe the vehicle, component or separate technical unit types covered by this type-approval certificate such characters shall be represented in the documentation by the symbol: “?” (e.g. ABC??123??).

⁽⁴⁾ As defined in Annex II A to Directive 2007/46/EC.

*Addendum***to EC type-approval certificate No ... concerning the component type-approval of spray suppression devices with regard to Directive 91/226/EEC as last amended by Directive 2010/19/EU**

1. Additional information

1.1. Operating principle of device: energy-absorption/air/water separator ⁽¹⁾:

1.2. Characteristics of spray-suppression devices (brief description, trademark or name, number(s)):

5. Remarks (if any):

⁽¹⁾ Delete where not applicable.

4. Annex III to Directive 91/226/EEC is amended as follows:

(a) points 0.1 and 0.2 are replaced by the following:

‘SCOPE

0.1. Category N and O vehicles, with the exception of off-road vehicles as defined in Annex II to Directive 2007/46/EC, shall be constructed and/or fitted with spray suppression systems in such a way as to meet the requirements laid down in this Annex. In case of chassis/cab vehicles, these requirements may only be applied to the wheels covered by the cab.

For vehicles of category N1 and N2 with a permissible maximum laden mass not exceeding 7,5 tonnes, the requirements of Directive 78/549/EEC (*) may be applied as alternative to the requirements of this Directive at the request of the manufacturer.

0.2. The requirements of this Annex relating to spray-suppression devices, as defined in point 4 of Annex I, are not mandatory for categories N, O₁ and O₂ vehicles with a permissible maximum laden mass not exceeding 7,5 tonnes, chassis/cab vehicles, unbodied vehicles or vehicles on which the presence of spray-suppression devices would be incompatible with their use. However, if such devices are fitted to those vehicles, they must conform to the requirements of this Directive.

(*) OJ L 168, 26.6.1978, p. 45.;

(b) point 4 is replaced by the following:

‘4. Position of outer valance

The distance “c” between the longitudinal plane tangential to the outer tyre wall, apart from any tyre bulge near the ground, and the inner edge of the valance must not exceed 100 mm (Figures 1a and 1b of Annex V).’;

(c) points 4.1 and 4.2 are deleted;

(d) point 7.1.1 is replaced by the following:

‘7.1.1. The mudguards must cover the zone immediately above, ahead and behind the tyre or tyres in the following manner:

(a) in the case of a single or multiple axle, the forward edge (C) must extend forwards to reach a line O-Z where ϑ (theta) is no more than 45° above the horizontal.

The rearmost edge (Figure 2 of Annex V) must extend downwards in such a way as not to be more than 100 mm above a horizontal line passing through the centre of the wheel;

(b) in the case of multiple axles the angle ϑ relates only to the foremost axle and the requirement relating to the height of the rearmost edge applies only to the rearmost axle;

(c) the mudguard must possess a total width "q" (Figure 1a of Annex V) at least adequate to cover the width of the tyre "b" or the entire width of two tyres "t" in the case of twin wheels, account being taken of the extremes for the tyre/wheel unit specified by the manufacturer. Dimensions "b" and "t" shall be measured at hub height, excluding any markings, ribs, protective bands, etc., on the tyre walls.;

(e) point 7.1.3 is replaced by the following:

7.1.3. If the mudguards are made up of several components, when fitted, they must not incorporate any aperture enabling spray to exit while the vehicle is in motion. This requirement is deemed to be met if, when the vehicle is either laden or unladen, any radial jet running outwards from the wheel centre over the entire width of the tyre running surface and within the range covered by the mudguard always strikes against a part of the spray suppression system.;

(f) points 7.2.1, 7.2.2 and 7.2.3 are replaced by the following:

7.2.1. In the case of single axles, the lower edge of the outer valance may not be situated beyond the following distances and radii, as measured from the centre of the wheel, except at the lowest extremities that may be rounded (Figure 2 of Annex V).

Air suspension:

- | | | |
|--|---|-------------------|
| (a) Axles fitted with steered wheels or self-steering wheels: | } | $R_v \leq 1,5 R$ |
| From the front edge (towards the front of the vehicle) (tip C)
To the rear edge (towards the rear of the vehicle) (tip A) | | |
| (b) Axles fitted with non-steered wheels: | } | $R_v \leq 1,25 R$ |
| From the front edge (tip C)
To the rear edge (tip A) | | |

Mechanical suspension

- (a) general case } $R_v \leq 1,8 R$
- (b) non-steered wheels for vehicles with a technically permissible laden mass more than 7,5 t } $R_v \leq 1,5 R$

where R is the radius of the tyre fitted to the vehicle, and R_v the distance, expressed as a radius, at which the lower edge of the outer valance is situated.

7.2.2. In the case of multiple axles the requirements laid down in point 7.2.1 do not apply between the vertical transversal planes passing through the centre of the first and the last axles where the outer valance may be straight in order to ensure the continuity of the spray suppression system. (Figure 4 of Annex V).

7.2.3. The distance between the uppermost and the lowermost points of the spray suppression system (mudguard and outer valance) measured in any cross section perpendicular to the mudguard (see figures 1b and 2 in Annex V) must extend to not less than 45 mm at all points behind a vertical line passing through the centre of the wheel or the first wheel in the case of multiple axles. This dimension may be gradually reduced in front of this line.;

(g) the following points 7.2.5 and 7.2.6 are inserted:

7.2.5. The requirements of points 7.2.3 and 7.2.4 may not be respected locally when the valance is composed by different elements with relative movement.

7.2.6. Tractors for semi-trailers with a low chassis (defined in point 6.20 of standard ISO 612 of 1978), namely those which may have a coupling pin height in relation to the ground equal to or less than 1 100 mm, may be designed in such a way as to be exempted from the requirements of points 7.1.1.a, 7.1.3 and 7.2.4. In this regard, mudguards and valances may not cover the area immediately above the tyres of the rear axles, when these tractors are coupled to a semi-trailer, in order to avoid the spray-suppression system being destroyed. However, the mudguards and valances of these vehicles must conform to the requirements of the above points, in sectors more than 60° from the vertical line passing through the centre of the wheel, in front and behind these tyres.

Those vehicles must therefore be designed in such a way as to meet the requirements set out in the first paragraph when they are operated without a semi-trailer.

In order to be able to meet those requirements, mudguards and valances may, for example, comprise a removable part.;

(h) point 7.3.1 is replaced by the following:

'7.3.1. The width of the flap must fulfil the requirement for "q" in point 7.1.1(c), except where the flap is within the mudguards, in which case it must be at least equal in width to the tread of the tyre.

The width of the part of the rain flaps positioned beneath the mudguard must satisfy the condition laid down in this paragraph with a tolerance of 10 mm at each side.;

(i) point 7.3.3 is replaced by the following:

'7.3.3. The maximum height of the bottom edge must not exceed 200 mm (Figure 3 of Annex V).

This distance is increased to 300 mm in the case of the last axle where the radial distance of the lower edge of the outer valancing, R_v , does not exceed the dimensions of the radius of the tyres fitted to the wheels on that axle.

The maximum height of the bottom edge of the rain flap in relation to the ground, may be raised to 300 mm if the manufacturer deems it technically appropriate with regard to the suspension characteristics.;

(j) in point 7.3.5, the reference to 'Figure 4b' is replaced by a reference to 'Figure 4 of Annex V';

(k) point 9.3.2.1 is replaced by the following:

'9.3.2.1. The lower edge of the spray-suppression device must be not more than 200 mm from the ground.

The maximum height of the bottom edge of the rain flap in relation to the ground, may be raised to 300 mm if the manufacturer deems it technically appropriate with regard to the suspension characteristics.;

(l) the following point 10 is added:

'10. In the case of multiple axles, the spray-suppression system of one axle, which is not the furthest back, may not need to cover the entire width of the tread of the tyre when there is, locally, the possibility of interference between the spray-suppression system and the structure of the axles or of the suspension or of the undercarriage.;

(m) the Appendix is deleted;

(n) the following Appendices 1 and 2 are added:

Appendix 1

INFORMATION DOCUMENT No ... RELATING TO EC TYPE-APPROVAL OF A VEHICLE WITH RESPECT TO THE FITTING OF SPRAY-SUPPRESSION SYSTEMS (DIRECTIVE 91/226/EEC, AS LAST AMENDED BY DIRECTIVE 2010/19/EU) (*)

(For the Explanatory notes please refer to Annex I to Directive 2007/46/EC)

The following information, if applicable, must be supplied in triplicate and include a list of contents. Any drawings must be supplied in appropriate scale and in sufficient detail on size A4 or on a folder of A4 format. Photographs, if any, must show sufficient detail.

If the systems, components or separate technical units have electronic controls, information concerning their performance must be supplied.

0. GENERAL

0.1. Make (trade name of manufacturer):

- 0.2. Type:
- 0.2.1. Commercial name(s) (if available):
- 0.3. Means of identification of type, if marked on the vehicle ^(b)
- 0.3.1. Location of that marking:
- 0.4. Category of vehicle ^(c):
- 0.5. Name and address of manufacturer:
- 0.8. Address(es) of assembly plant(s):
1. GENERAL CONSTRUCTION CHARACTERISTICS OF THE VEHICLE
- 1.1. Photographs and/or drawings of a representative vehicle:
- 1.3. Number of axles and wheels:
- 1.3.1. Number and position of axles with twin wheels:
- 1.3.2. Number and position of steered axles
2. MASSES AND DIMENSIONS ^(f) ^(g)
(in kg and mm) (Refer to drawing where applicable)
- 2.1. Wheelbase(s) (fully loaded) ^(g) ^(h):
- 2.6. Mass in running order (maximum and minimum for each variant)
- Mass of the vehicle with bodywork and, in the case of a towing vehicle of category other than M₁, with coupling device, if fitted by manufacturer, in running order, or mass of the chassis or chassis with cab, without bodywork and/or coupling device if the manufacturer does not fit the bodywork and/or coupling device (including liquids, tools, spare wheel, if fitted, and driver and, for buses and coaches, a crew member if there is a crew seat in the vehicle) ^(h) (maximum and minimum for each variant):
- 2.6.1. Distribution of this mass among the axles and, in the case of a semi-trailer or centre-axle trailer, load on the coupling point (maximum and minimum for each variant):
- 2.8. Technically permissible maximum laden mass stated by the manufacturer ⁽ⁱ⁾ ^(j):
9. BODYWORK
- 9.20. Spray-suppression system
- 9.20.0. Presence: yes/no/incomplete ^(l)
- 9.20.1. Brief description of the vehicle with regard to its spray-suppression system and the constituent components:
- 9.20.2. Detailed drawings of the spray-suppression system and its position on the vehicle showing the dimensions specified in the Figures in Annex V to Directive 91/226/EEC and taking account of the extremes of tyre/wheel combinations:
- 9.20.3. Approval number(s) of spray-suppression device(s), if available:

Date, File

^(*) For vehicles of category N1 and those of category N2 with a technically permissible maximum laden mass not exceeding 7,5 tons using the derogation of point 0.1 of Annex III to this Directive, the information document set out in Annex II to Directive 78/549/EEC may be used.

Appendix 2

MODEL

(maximum format: A4 (210 × 297 mm))

EC TYPE-APPROVAL CERTIFICATE

Stamp of type-approval authority

Communication concerning:

- EC type approval ⁽¹⁾
- Extension of EC type approval ⁽¹⁾
- Refusal of EC type approval ⁽¹⁾
- Withdrawal of EC type approval ⁽¹⁾

of a type of a vehicle/component/separate technical unit with regard to Directive 91/226/EEC, as last amended by Directive 2010/19/EU ⁽¹⁾

Type-approval number:

Reason for extension:

SECTION I

- 0.1. Make (trade name of manufacturer):
- 0.2. Type:
- 0.3. Means of identification of type if marked on the vehicle/component/separate technical unit ⁽¹⁾ ⁽²⁾
 - 0.3.1. Location of that marking:
- 0.4. Category of vehicle ⁽²⁾ ⁽³⁾
- 0.5. Name and address of manufacturer:
- 0.7. In the case of components and separate technical units, location and method of affixing of the EC approval mark:
- 0.8. Address(es) of assembly plant(s):

SECTION II

1. Additional information (where applicable): See Addendum
2. Technical service responsible for carrying out the tests:
3. Date of test report:
4. Number of test report:
5. Remarks (if any): See Addendum
6. Place:
7. Date:
8. Signature:
9. The index to the information package lodged with the approval authority, which may be obtained on request, is attached.

⁽¹⁾ Delete where not applicable.

⁽²⁾ If the means of identification type contains characters not relevant to describe the vehicle, component or separate technical unit types covered by this type-approval certificate such characters shall be represented in the documentation by the symbol: "?" (e.g. ABC??123??).

⁽³⁾ As defined in Annex II A to Directive 2007/46/EC.

Addendum

TO EC TYPE-APPROVAL CERTIFICATE No ... CONCERNING THE TYPE APPROVAL OF A VEHICLE WITH REGARD
TO DIRECTIVE 91/226/EEC AS LAST AMENDED BY DIRECTIVE 2010/19/EU

1. Additional information
 - 1.1. Characteristics of the spray-suppression devices (type, brief description, trade mark or name, component type-approval number(s):
 5. Remarks (if any):
-

ANNEX II

ANNEX V

FIGURES

Figure 1a

Width (q) of mudguard (a) and position of valance (j)

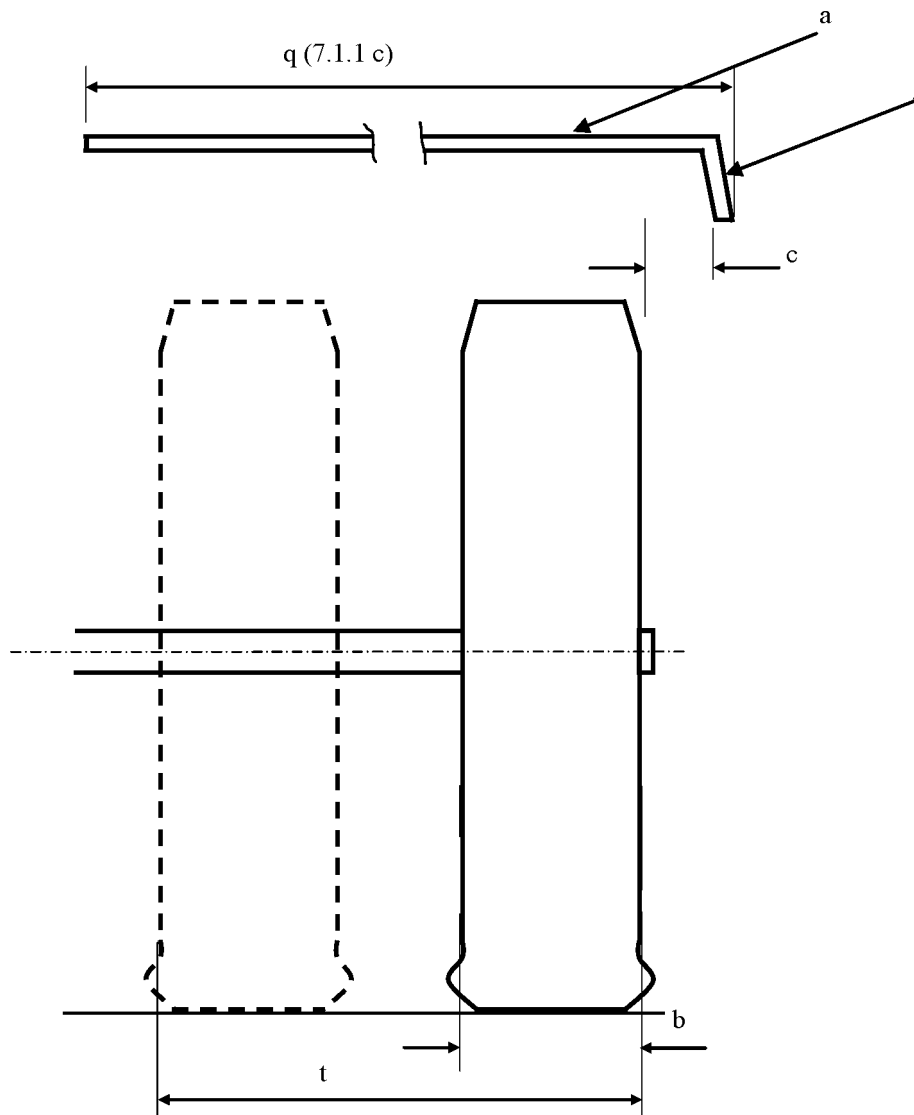

Note: The figures refer to the corresponding items in Annex III.

Figure 1b

Example of measurement of the outer valance



Figure 2
Dimensions of mudguard and outer valance

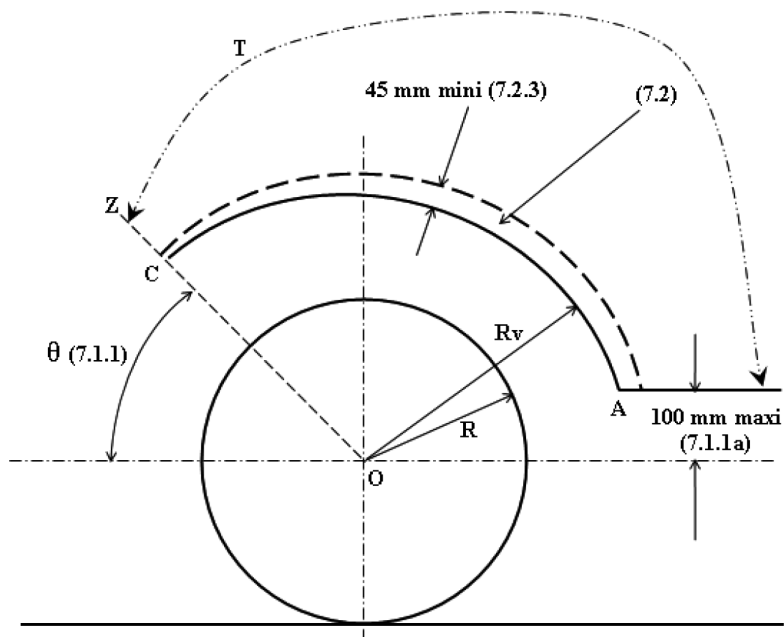

Note

1. The figures quoted relate to the corresponding items in Annex III.
2. T: extent of mudguard.

Figure 3
Position of mudguard and rain flap

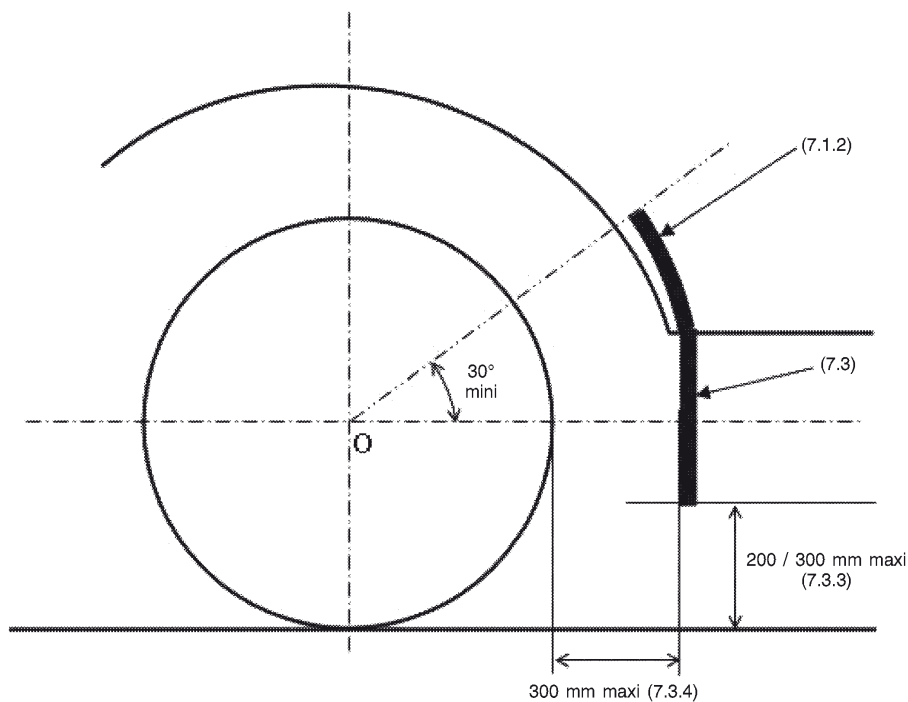

Note: The figures quoted relate to the corresponding items in Annex III.

Figure 4

Diagram showing assembly of a spray-suppression system (mudguard, rain flap, outer valance) incorporating spray-suppression devices (energy absorbers) for multiple axles

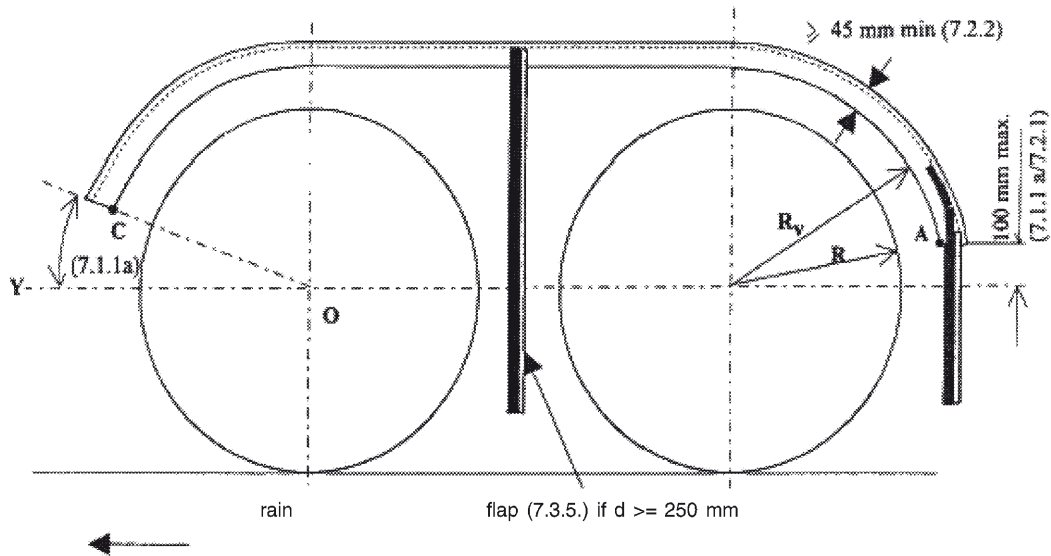
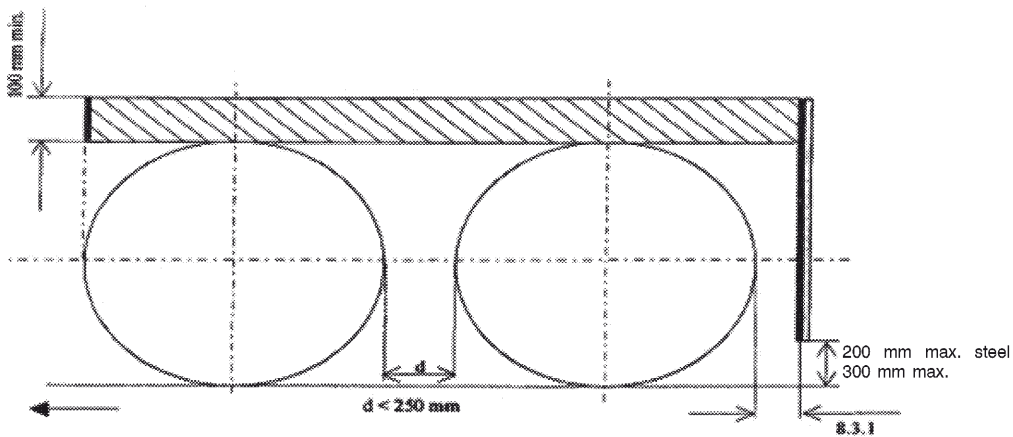

Figure 5

Diagram showing assembly of a spray-suppression system incorporating spray-suppression devices (energy absorbers) for axles fitted with non-steered or self-steering wheels

(Annex III — items 6.2 and 8)



(a) Multiple axles where the distance between the tyres is less than 250 mm.

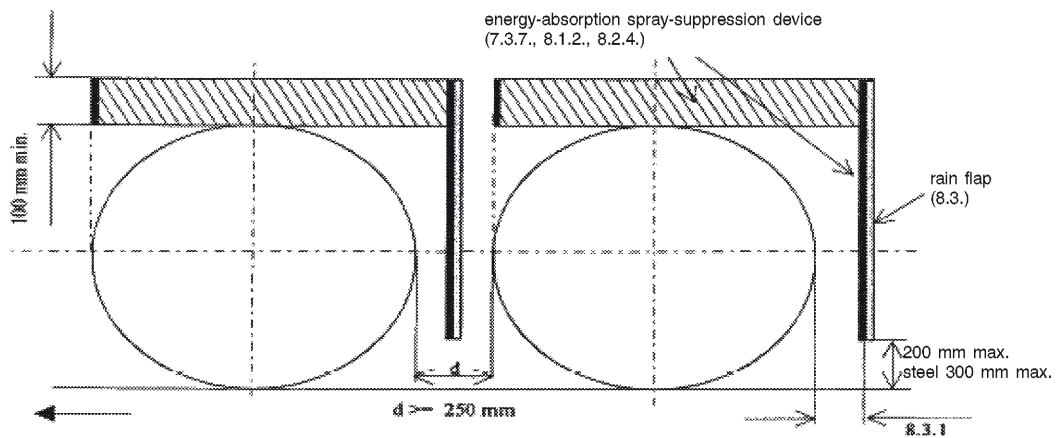

(b) Single axles or multiple axles where the distance between the tyres is not less than 250 mm.

Figure 6

Diagram showing assembly of a spray-suppression system incorporating spray-suppression devices fitted with air/water separators for axles fitted with steered, self-steering or non-steered wheels

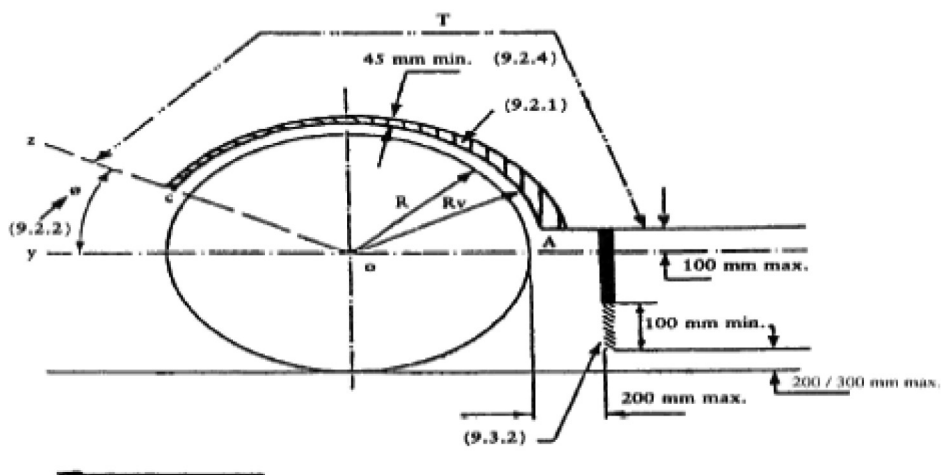

Note

1. The figures relate to the corresponding items in Annex III.
2. T: extent of mudguard.

Figure 7

Diagram showing assembly of a spray-suppression system incorporating spray-suppression devices (mudguard, rain flap, outer valance) for multiple axles where the distance between the tyres does not exceed 300 mm

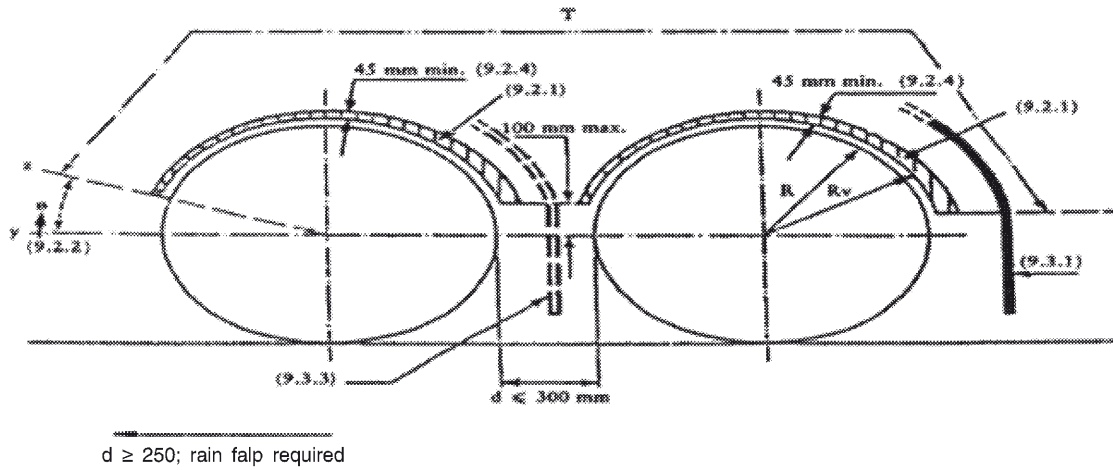

Note

1. The figures relate to the corresponding items in Annex III.
2. T: extent of mudguard.

Figure 8

Test assembly for energy absorption spray-suppression devices

(Annex II, Appendix 1)

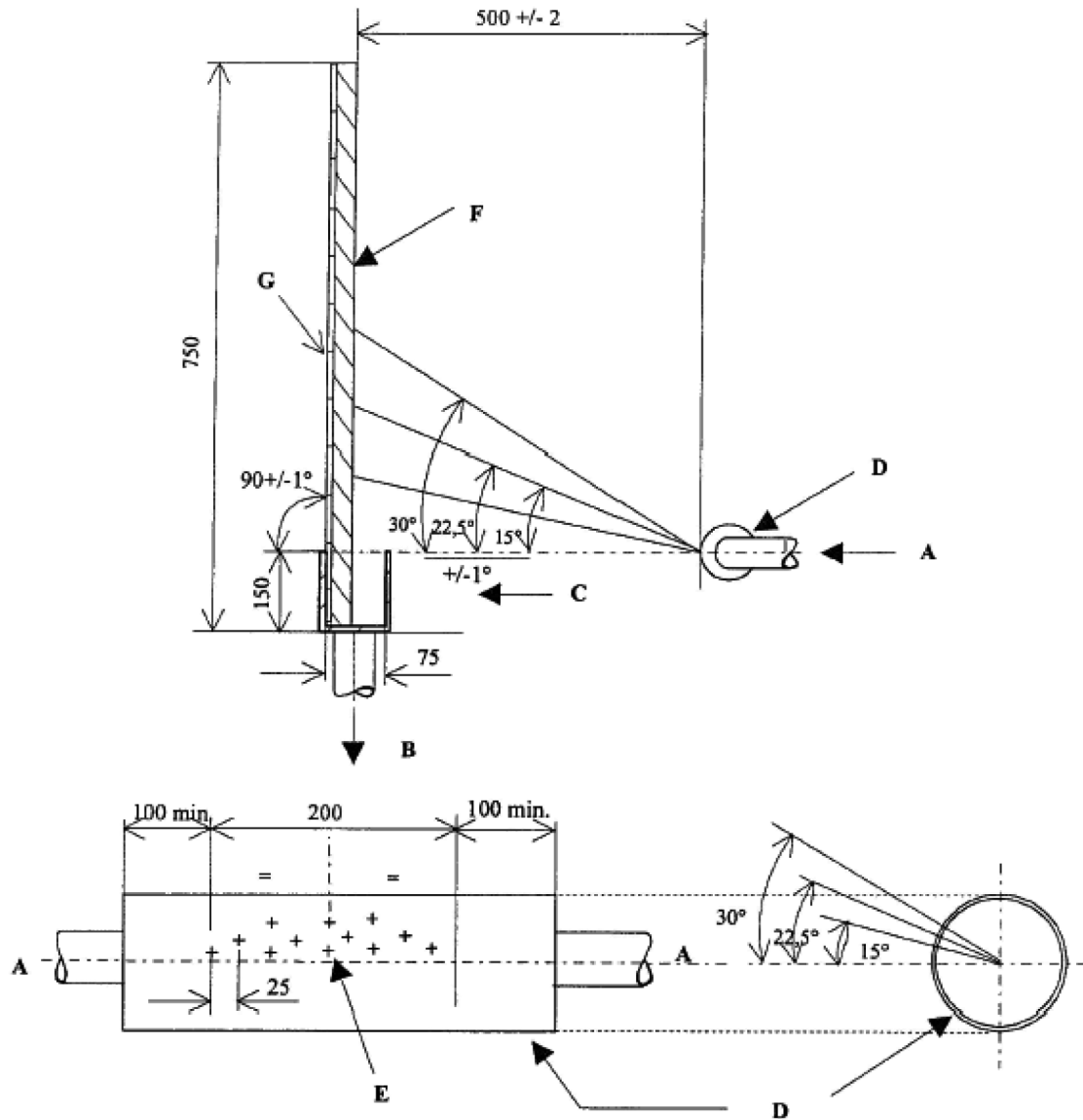

Note

A = water supply from pump

B = flow towards collector tank

C = collector with inside dimension of 500 (+ 5/- 0) mm length and 75 (+ 2/- 0) mm width

D = stainless steel pipe, external diameter 54 mm, wall thickness 1,2 (+/- 0,12) mm, inside and outside surface roughness Ra between 0,4 and 0,8 µm

E = 12 cylindrical radially drilled holes with burr-free square edges. Their diameter, measured on the inside and on the outside of the tube, is 1,68 (+ 0,010/- 0) mm

F = 500 (+ 0/- 5) mm-wide sample to be tested

G = rigid flat plate

All linear dimensions are shown in millimetres.

Figure 9

Test assembly for air/water separator spray-suppression devices

(Annex II, Appendix 2)

