

COUNCIL DIRECTIVE

of 27 March 1991

on the approximation of the laws of the Member States relating to the spray-suppression systems of certain categories of motor vehicles and their trailers

(91/226/EEC)

THE COUNCIL OF THE EUROPEAN COMMUNITIES,

Having regard to the Treaty establishing the European Economic Community, and in particular Article 100a thereof,

Having regard to the proposal from the Commission ⁽¹⁾,

In cooperation with the European Parliament ⁽²⁾,

Having regard to the opinion of the Economic and Social Committee ⁽³⁾,

Whereas it is important to adopt measures with the aim of progressively establishing the internal market over a period expiring on 31 December 1992; whereas the internal market shall comprise an area without internal frontiers in which the free movement of goods, persons, services and capital is ensured;

Whereas the technical requirements which certain categories of motor vehicles and their trailers must satisfy pursuant to national laws relate, *inter alia*, to the spray-suppression systems of such motor vehicles;

Whereas these requirements differ from one Member State to another; whereas it is therefore necessary that all Member States adopt the same requirements in order, in particular, to allow the implementation for each type of vehicle of the EEC type-approval procedure which was the subject of Council Directive 70/156/EEC of 6 February 1970 on the approximation of the laws of the Member States relating to the type-approval of motor vehicles and their trailers ⁽⁴⁾, as last amended by Directive 87/403/EEC ⁽⁵⁾;

Whereas, with a view to improving road safety, it is important that all commercial vehicles in higher weight categories and with a certain minimum design speed should be equipped with efficient spray-suppression systems in order to retain water;

Whereas it is desirable to establish a single performance test for systems of this type on fitting to the various types of vehicles as a means of markedly improving the situation;

whereas for the EEC component type-approval of devices of this type account has been taken of the two types of devices currently on the market, i.e. the energy-absorption type and the air/water separator type; whereas it has been necessary to provide for two different tests depending on the type of device to be approved;

Whereas, in the light of the studies, research and tests currently in progress, a performance test on the types of vehicles fitted with these devices will be established as soon as possible;

Whereas Member States should pay attention to the fact that the formation of spray depends also on the characteristics of the road surface, the tyre-tread configuration and the speed and aerodynamic characteristics of the vehicle;

Whereas the approximation of national laws relating to motor vehicles entails the mutual recognition by Member States of the inspections carried out by each of them on the basis of common requirements,

HAS ADOPTED THIS DIRECTIVE:

Article 1

1. Member States shall grant EEC component type-approval for any type of device, hereinafter referred to as 'spray-suppression device', intended to reduce the projection of spray from tyres of moving vehicles, if it satisfies the requirements regarding design and testing set out in Annex II and taking into account the definitions given in Annex I.

2. A Member State which has granted EEC component type-approval shall take the measures required to verify, in so far as is necessary and, if need be, in cooperation with the competent authorities of the other Member States, that production models conform to the approved type. For this purpose the Member State shall apply the requirements of Annex IV.

Article 2

Member States shall, for each spray-suppression device which they approve pursuant to Article 1, issue to the

⁽¹⁾ OJ No C 203, 14. 8. 1990, p. 16.

⁽²⁾ OJ No C 96, 17. 4. 1990, p. 92 and Decision of 13 March 1991 (not yet published in the Official Journal).

⁽³⁾ OJ No C 62, 12. 3. 1990, p. 2.

⁽⁴⁾ OJ No L 42, 23. 2. 1970, p. 1.

⁽⁵⁾ OJ No L 220, 8. 8. 1987, p. 44.

manufacturer or to his authorized representative an EEC component type-approval mark conforming to the model in Annex II, Appendix 3.

Member States shall take all appropriate measures to prevent the use of marks liable to create confusion between spray-suppression devices which have been approved pursuant to Article 1 and other devices.

Article 3

No Member State may prohibit the placing on the market of spray-suppression devices on grounds relating to their construction and performance if they bear the EEC component type-approval mark.

Nevertheless, this provision shall not prevent a Member State from taking such measures with regard to spray-suppression devices bearing the EEC component type-approval mark which consistently fail to conform to the approved type.

The Member State concerned shall forthwith inform the other Member States and the Commission of the measures taken, specifying the reason for its decision. The provisions of Article 5 shall also apply.

Devices shall be deemed not to conform to the approved type, within the meaning of the second paragraph, if the requirements of Annex II have not been respected.

Article 4

The competent authorities of each Member State shall, within one month, send the competent authorities of the other Member States copies of the EEC component type-approval certificates issued for each type of spray-suppression device which they approve or refuse to approve.

Article 5

1. If the competent authorities of a Member State which has granted EEC component type-approval find that spray-suppression devices accompanied by certificates of conformity to a single type do not conform to the type approved by that Member State, they shall take the necessary measures to ensure that the conformity of production models to the approved type is restored. They shall advise the competent authorities of the other Member States of the measures taken, which may extend to withdrawal of EEC component type-approval.

The said authorities shall take the same measures if they are informed by the competent authorities of another Member State of such failure to conform.

2. The competent authorities of the Member State shall, within one month, inform each other of a withdrawal of EEC component type-approval, by forwarding a copy of the component type-approval certificate, signed and dated and bearing in large letters the words 'EEC TYPE-APPROVAL WITHDRAWN', and adducing reasons for any such measure.

3. If the Member State which has granted the EEC component type-approval challenges the alleged lack of conformity, the Member States concerned shall endeavour to settle the disagreement. The Commission shall be kept informed. Where necessary, it shall arrange for appropriate discussions with a view of arriving at a solution.

Article 6

Any decision taken pursuant to the provisions adopted in implementation of this Directive to refuse or withdraw EEC component type-approval for spray-suppression devices or prohibit their placing on the market or use shall set out in detail the reason on which it is based. Such decision shall be notified to the party concerned, who shall at the same time be informed of the remedies available to him under the laws in force in the Member States and of the time limits laid down for availing himself of such remedies.

Article 7

For the purposes of this Directive, 'vehicle' means any motor vehicle in category N and any trailer in category O as defined in Annex I to Directive 70/156/EEC.

Article 8

No Member State may refuse to grant EEC type-approval or national type-approval for vehicles, or refuse or prohibit their sale, registration, placing in service or use on grounds relating to their spray-suppression system if these are fitted in accordance with the requirements of Annex III and if the spray-suppression devices with which the vehicles are equipped bear the EEC component type-approval mark.

Article 9

Any amendments necessary in order to adapt the requirements of the Annexes to this Directive to take account of technical progress shall be adopted in accordance with the procedure laid down in Article 13 of Directive 70/156/EEC.

Article 10

1. Member States shall bring into force the provisions necessary in order to comply with this Directive by 10 April 1992. They shall forthwith inform the Commission thereof.

2. Member States shall communicate the main provisions of national law which they adopt in the field covered by this Directive to the Commission.

3. When Member States adopt the provisions referred to in paragraph 1, they shall contain a reference to this Directive or be accompanied by such reference on the occasion of their official publication. The methods of making such a reference shall be laid down by the Member States.

Article 11

This Directive is addressed to the Member States.

Done at Brussels, 27 March 1991.

For the Council
The President
R. GOEBBELS

LIST OF ANNEXES

- ANNEX I: Definitions
- ANNEX II: Requirements relating to the EEC component type-approval of spray-suppression devices
- Appendix 1: Tests on spray-suppression devices of the energy absorber type
- Appendix 2: Tests on spray-suppression devices of the air/water separator type.
- Appendix 3: Model for the EEC component type-approval mark
- Appendix 4: Model for the EEC component type-approval certificate
- ANNEX III: Requirements relating to the EEC type-approval of a type of vehicle with regard to the fitting of spray-suppression systems.
- Appendix: Annex to the EEC type-approval certificate in respect of a type of vehicle with regard to the fitting of spray-suppression systems.
- ANNEX IV: Conformity of production
- Cessation of production.
- FIGURES: (1 to 9)

ANNEX I

DEFINITIONS

For the purposes of this Directive, the following definitions apply:

1. *Spray-suppression system*

'Spray-suppression system' means a system intended to reduce the pulverization of water thrown upwards by the tyres of a vehicle in motion. The spray-suppression system is variously made up of a mudguard, rain flaps and valances equipped with a spray-suppression device.

2. *Mudguard*

'Mudguard' means a rigid or semi-rigid component intended to trap the water thrown up by tyres in motion and to direct it towards the ground. Mudguards may entirely or partially form an integral part of the vehicle bodywork or other parts of the vehicle such as the lower part of the load platform, etc.

3. *Rain flap*

'Rain flap' means a flexible component mounted vertically behind the wheel, on the lower part of the chassis or the loading surface, or on the mudguard.

The rain flap must also reduce the risk of small objects, in particular pebbles, being picked up from the ground by the tyres and thrown upwards or sideways towards other road users.

4. *Spray-suppression device*

'Spray-suppression device' means part of the spray-suppression system, which may comprise:

4.1. *Air/water separator*

This is a component forming part of the valance and/or of the rain flap through which air can pass whilst reducing pulverized water emissions.

4.2. *Energy absorber*

This is a component forming part of the mudguard and/or valance and/or rain flap which absorbs the energy of water spray, thus reducing pulverized water spray.

5. *Outer valance*

'Outer valance' means a component located approximately within a vertical plane that is parallel to the longitudinal plane of the vehicle. It may form part of a mudguard or of the vehicle bodywork.

6. *Steered wheels*

'Steered wheels' means the wheels actuated by the vehicle's steering system.

7. *Self-tracking axle*

'Self-tracking axle' means an axle pivoted about a central point in such a way that it can describe a horizontal arc. For the purpose of this Directive, a self-tracking axle of the 'pivot steering' type is considered to be, and treated as, an axle fitted with steered wheels.

8. *Self-steered wheels*

'Self-steered wheels' means wheels not actuated by the vehicle's steering device, which may swivel through an angle not exceeding 20° owing to the friction exerted by the ground.

9. *Lifting axle*

'Lifting axle' means an axle which can be lifted from the road during normal vehicle use.

10. *Unladen vehicle*

'Unladen vehicle' means a bodied vehicle (or with one or more representative components) and, where appropriate, with coolant liquid, lubricants, fuel, tools, spare wheel, and driver having an estimated mass of 75 kg.

11. *Tyre contact patch*

'Tyre contact patch' means the part of the tyre, in contact with the road (surface), which provides grip.

12. *Type of spray-suppression device*

'Type of spray-suppression device' means devices which do not differ with respect to the following main characteristics:

- the physical principle adopted in order to reduce emissions (water-energy absorption, air/water separator),
- materials,
- shape,
- dimensions (in so far as they may influence the behaviour of the material).

ANNEX II

REQUIREMENTS RELATING TO THE EEC COMPONENT TYPE-APPROVAL OF
SPRAY-SUPPRESSION DEVICES

0. **General specifications**
- 0.1. Spray-suppression devices must be constructed in such a way that they operate properly when used normally on wet roads. Moreover, they must incorporate no structural or manufacturing defect detrimental to their proper functioning or behaviour.
1. **Tests to be carried out**
- 1.1. Depending on their physical operating principle spray-suppression devices are subjected to the relevant tests as described in Appendices 1 and 2 and must deliver the results required in item 4 of those Appendices.
2. **Application for EEC component type-approval**
- 2.1. The application for EEC component type-approval of a type of spray-suppression device is submitted by the manufacturer or by his authorized representative.
- 2.2. For each type the application is accompanied by the following documents in triplicate and by the following information and materials:
- 2.2.1. A technical description of the spray-suppression device indicating its physical operating principle and the relevant test to which it must be subjected, the materials used and one or more drawings in sufficient detail and to an appropriate scale to enable this (or these) to be identified.
- 2.2.2. Four samples: three of which for tests and a fourth to be kept by the laboratory for any subsequent verification. The test laboratory may require further samples.
- 2.3. **Markings**
- Each sample must be clearly and indelibly marked with the trade name or mark and an indication of the type and include a space that is large enough for the EEC component type-approval mark.
3. **EEC component type-approval**
- 3.0. Before carrying out the procedures for granting EEC component type-approval, the competent authority must check that the manufacturer has effective systems for monitoring production conformity.
- 3.1. Where the samples that are representative of the type of device to be type-approved pass the relevant tests as described in Appendices 1 or 2, EEC component type-approval is issued for that type of spray-suppression device.
- 3.2. A component type-approval number is assigned to each type of EEC approved spray-suppression device.
- 3.3. Any spray-suppression device in conformity with a type approved pursuant to this Directive must bear an EEC component type-approval mark, so affixed as to be indelible and easily legible even when the device is fitted to the vehicle.
- 3.4. The EEC component type-approval mark (a model for which is shown in Appendix 3) consists of:
- 3.4.1. a rectangle surrounding the lower-case letter 'e', followed by the distinguishing letter(s) or number of the Member State which has granted the EEC component type-approval:
1 for Germany, 2 for France, 3 for Italy, 4 for the Netherlands, 6 for Belgium, 9 for Spain, 11 for the United Kingdom, 13 for Luxembourg, 18 for Denmark, 21 for Portugal, EL for Greece and IRL for Ireland;
- 3.4.2. the EEC component type-approval number (corresponding to the number on the component type-approval certificate, a model for which is shown in Appendix 4), which is placed close to the rectangle, either below the letter 'e', or to the left or right of that letter. The digits of the component type-approval number are placed on the same side of the letter 'e' and face the same direction. The use of Roman numerals in component type-approval numbers must be avoided in order to prevent any confusion with other symbols;
- 3.4.3. the letter 'A' or the letter 'S', depending on whether the device is of the energy-absorption type (A) or of the air/water separator type (S), located in any position above and close to the rectangle.

*Appendix 1***Tests on spray-suppression devices of the energy-absorber type****1. Principle**

The aim of this test is to quantify the ability of a device to retain the water directed against it by a series of jets. The test assembly is intended to reproduce the conditions under which the device is to function when fitted to a vehicle as regards the volume and speed of the water thrown up from the ground by the tyre tread.

2. Equipment

See Figure 8 for a description of the test assembly. The tests are carried out in a still-air environment.

3. Procedure

- 3.1. Secure a 500 (+ 0/ - 5) mm wide, 750 mm high sample of the equipment to be tested to the vertical frame of the testing equipment, making sure that the sample lies well within the limits of the collector, and that no obstacle is able to deflect the water, either before or after its impact.
- 3.2. Set the water flowrate at 0,675 ($\pm 0,01$) l/s and direct at least 90 l on to the sample from a horizontal distance of 500 (± 2) mm (Figure 8).
- 3.3. Allow the water to trickle from the sample into the collector and calculate the percentage (difference) between the quantity of water collected and the quantity of water sprayed.
- 3.4. Repeat the test five times and calculate the average percentage amount of water collected.

4. Results

- 4.1. The calculated average percentage of water collected during the five tests must not be less than 70 % of the amount of water directed on to the device.
- 4.2. If the highest and lowest percentages of water collected depart from the average percentage by more than 5 %, the test is not valid and must be repeated.
If even in the second test the highest and lowest percentages of water recovered again depart from the average percentage by more than 5 % and/or if the lower value does not satisfy the requirements of item 4.1, approval is refused.
- 4.3. Where the vertical position of the device influences the results obtained, the procedure described in items 3.1 and 3.4 must be repeated in the positions giving the highest and lowest percentage of water collected; the requirements of item 4.2 remain in force.
The requirements of item 4.1 remain in force in order to give the result of each test.

*Appendix 2***Test on spray-suppression devices of the air/water separator type****1. Principle**

This test is intended to determine the effectiveness of a porous material intended to retain the water with which it has been sprayed by means of a pressurized air/water pulverizer.

The equipment used for the test must simulate the conditions to which the material would be submitted, with regard to the volume and speed of the water sprays produced by the tyres, if it were fitted to a vehicle.

2. Equipment

- 2.1. The test assembly is as described in Figure 9.

3. Procedure

- 3.1. Secure a 305 × 100 mm sample vertically in the test assembly, check that there is no space between the sample and the upper curved plate and that the tray is properly in position. Fill the pulverizer tank with exactly one litre of water and place this as described in the diagram.

- 3.2. The pulverizer must be regulated as follows:

pressure (at pulverizer): 5 bar + 10% / - 0%

flowrate: 1 litre/minute ± 5 seconds

pulverization: circular, roughly 50 mm in diameter at 200 mm from the sample, nozzle 5 mm in diameter.

- 3.3. Pulverize until there is no more water mist and note the time taken. Let the water flow out of the sample on to the tray for 60 seconds and measure the volume of water collected. Measure the quantity of water left in the pulverizer tank. Calculate the percentage by volume of water collected versus the volume of water pulverized.
- 3.4. Repeat the test five times and calculate the average percentage of the quantity collected. Check before each test that the tray, pulverizer tank and measuring vessel are dry.
- 3.5. During the test the ambient temperature must be 21 (± 3) °C.

4. Results

- 4.1. The calculated average percentage of water collected at the end of five tests must not be less than 85 % of the quantity of water sprayed on to the device.

- 4.2. If the highest and lowest percentages of water collected vary by more than 5 % of the average percentage, the test is not valid and must be repeated.

If even in the second test the highest and lowest percentages of water recovered again depart from the average percentage by more than 5 %, and/or if the lower value does not satisfy the requirements of item 4.1, approval is refused.

- 4.3. Where the vertical position of the device influences the results obtained, the procedure described in items 3.1 and 3.4 must be repeated in the positions giving the highest and lowest percentages of water collected; the requirements of item 4.2 remain in force.

The requirement of item 4.1 remain in force in order to give the results of each test.

Appendix 3

Model for the EEC component type-approval mark

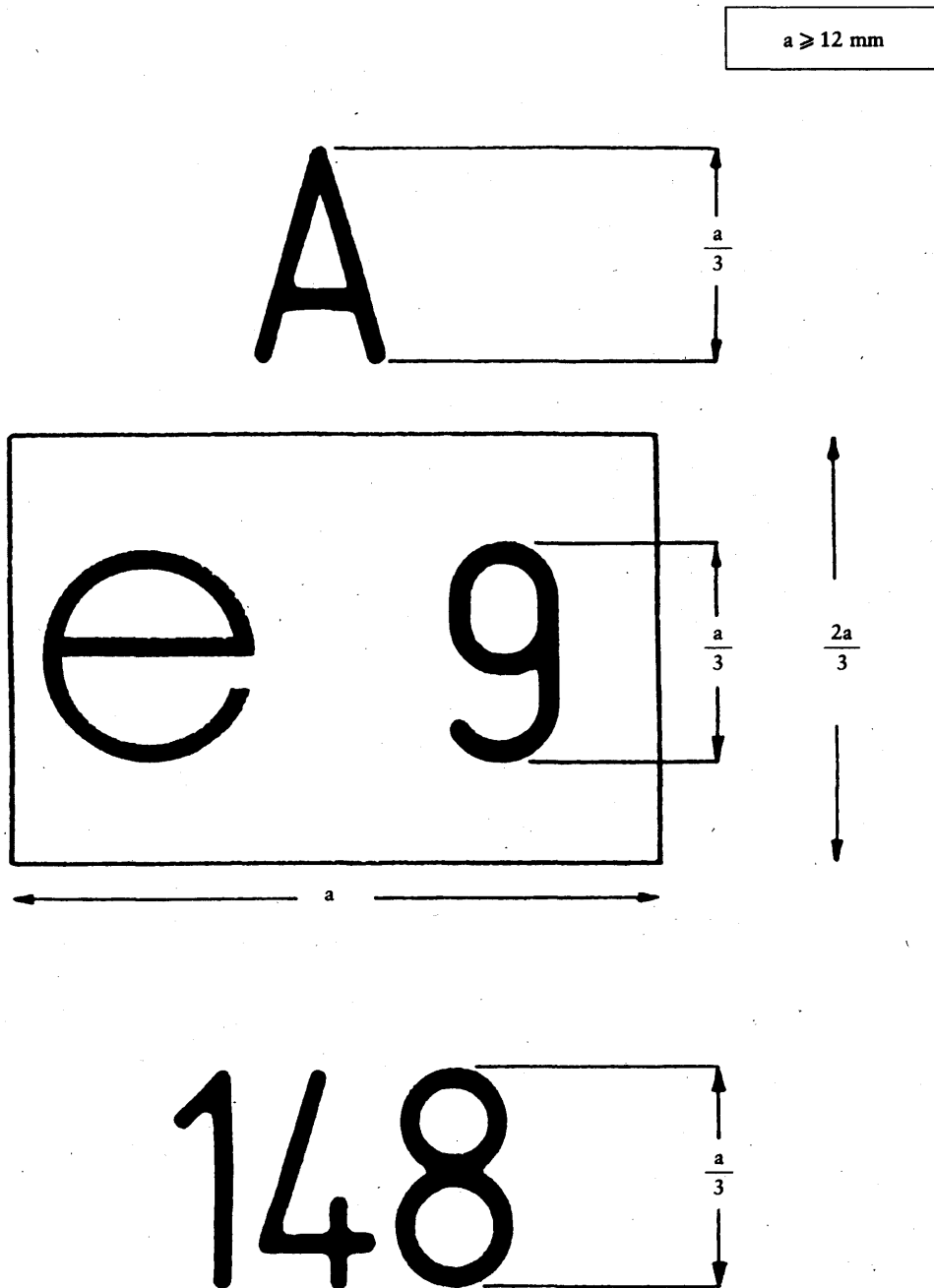

The spray-suppression device bearing the above EEC type-approval mark is a device of the energy-absorption type (A), which has been approved in Spain (e 9) under number 148.

The figures used are only indicative.

Appendix 4

MODEL FOR THE EEC COMPONENT TYPE-APPROVAL CERTIFICATE

(Maximum format: A4 (210 x 297 mm))

e . . .

Name of Administration

Communication concerning the granting, refusal, withdrawal or extension of EEC component type-approval in respect of a type of spray-suppression device

EEC component type-approval No: Extension No:

- 1. Trade mark of device:
- 2. Type and trade description of device:
- 3. Operating principle of device: energy-absorption/ air/ water separator (*):
- 4. Name and address of manufacturer:
- 5. Name and address of manufacturer's authorized representative (if any):
- 6. Characteristics of spray-suppression devices (brief description, trade mark or name, number(s):
- 7. Date on which submitted for EEC component type-approval:
- 8. Technical service responsible for the component type-approval tests:
- 9. Date and number of test report issued by the technical service:
- 10. Date on which EEC component type-approval was granted/refused/withdrawn/extended (*)
- 11. Reason(s) for the extension of EEC component type-approval (where applicable):
- 12. Place:
- 13. Date:
- 14. Signature:
- 15. Annexed: the documents making up the EEC component type-approval file, and a list thereof, deposited with the competent authorities which granted that approval; a copy of some or all of the documents can be obtained on request.
- 16. Remarks (if any):

(*) Delete as appropriate.

ANNEX III

REQUIREMENTS RELATING TO THE EEC TYPE-APPROVAL OF A TYPE OF VEHICLE WITH REGARD TO THE FITTING OF SPRAY-SUPPRESSION SYSTEMS

SCOPE

- 0.1. All category N₂ vehicles of a maximum mass exceeding 7,5 tonnes, and all category N₃, O₃ and O₄ vehicles must be constructed and/or fitted with spray-suppression devices in such a way as to meet the requirements below.
- 0.2. The requirements laid down above relating to spray-suppression devices as defined in section 4 of Annex I are not mandatory in the case of chassis/cab vehicles, unbodied vehicles, 'off-road' vehicles as defined in Directive 70/156/EEC, or vehicles in which the presence of spray-suppression devices is incompatible with their use. However, if such devices are fitted to these vehicles, they must conform to the requirements of this Directive.

APPLICATION FOR EEC TYPE-APPROVAL

- 1.1. The application for EEC type-approval of a vehicle type with regard to the fitting of a spray-suppression system must be submitted by the vehicle manufacturer or by his authorized representative.
- 1.2. It must be accompanied by the following documents in triplicate, and by the following particulars:
 - 1.2.1. a technical description of the spray-suppression system and one or more sufficiently detailed drawings on a scale suitable for identification.
- 1.3. A vehicle representative of the vehicle type to be approved, fitted with its spray-suppression system, must be submitted to the technical service conducting the approval tests.

EEC TYPE-APPROVAL

2. A certificate conforming to the model shown in the Appendix must be attached to the EEC type-approval certificate.

GENERAL REQUIREMENTS

3. **Axles**
 - 3.1. *Lifting axles*

Where a vehicle is fitted with one or more lifting axles, the spray-suppression system must cover all the wheels when the axle is lowered and the wheels in contact with the ground when the axle is raised.
 - 3.2. *Self-tracking axles*

Where a vehicle is fitted with a self-tracking axle, the spray-suppression system must satisfy the conditions applicable to non-steered wheels if mounted on the pivoting part. If not mounted on that part it must satisfy the conditions that are applicable to steered wheels.
4. **Position of outer valance**
 - 4.1. In the case of non-steered wheels distance 'c' between the longitudinal plane tangential to the outer tyre wall, apart from any tyre bulge near the ground, and the inner edge of the valance must not exceed 75 mm unless the radius of the inner edge of the valance, as defined in items 7.2, 8.2 and 9.2, is less than 1,0 R, in which case it must not exceed 100 mm (Figure 1).
 - 4.2. In the case of steered and self-steered wheels, distance 'c' must not exceed 100 mm.

5. State of vehicle

For the checking of compliance with this Directive the vehicle must be in the following state:

- (a) it must be unladen and with the wheels in the straight-ahead position;
- (b) in the case of semi-trailers, the loading surfaces must be horizontal;
- (c) the tyres must be inflated to their normal pressure.

6. Spray-suppression systems

- 6.1. The spray-suppression system must meet the specifications set out in item 7 or 9.
- 6.2. The spray-suppression system for non-steered or self-steered wheels that are covered by the bodywork floor, or by the lower part of the load platform, must meet either the specifications set out in item 7 or 9 or else those in item 8.

SPECIFIC REQUIREMENTS

7. Requirements concerning energy-absorption spray-suppression systems for axles fitted with steered or self-steering or non-steered wheels

7.1. *Mudguards*

- 7.1.1. The mudguards must cover the zone immediately above, ahead and behind the tyre or tyres in the following manner:

- (a) in the case of a single or multiple axle where distance 'd' (Figure 4) between the tyres fitted to the adjacent axles exceeds 300 mm, the forward edge (C) must extend forwards to reach a line O—Z where $F15u(\theta) = \text{no more than } 30^\circ$ above the horizontal for axles fitted with steering or self-steering wheels, and no more than 20° for axles fitted with non-steered wheels.

The rearmost edge (Figure 2) must extend downwards in such a way as not to be more than 100 mm above a horizontal line passing through the centre of the wheel;

- (b) in the case of multiple axles where the distance 'd' between the tyres fitted to the adjacent axles does not exceed 300 mm, the mudguard must be as shown in Figure 4a;
- (c) the mudguard must possess a total width 'q' (Figure 1) at least adequate to cover the entire width of the tyre 'b' or the entire width of two tyres 't' in the case of twin wheels, account being taken of the extremes for the tyre/wheel unit specified by the manufacturer. Dimensions 'b' and 't' shall be measured at hub height, excluding any markings, ribs, protective bands, etc., on the tyre walls.

- 7.1.2. The front side of the rear part of the mudguard must be fitted with a spray-reduction device complying with the specifications set out in Appendix 1 to Annex II. This material must cover the inside of the mudguard up to a height determined by a straight line running from the centre of the wheel and forming an angle of at least 30° with the horizontal (Figure 3).

- 7.1.3. If the mudguards are made up of several components when fitted, they must not incorporate any aperture enabling spray to exit while the vehicle is in motion.

7.2. *Outer valances*

- 7.2.1. In the case of single axles, or multiple axles where distance 'd' between the tyres on adjacent axles exceeds 300 mm, the lower edge of the outer valance may not be situated beyond the following distances and radii, as measured from the centre of the wheel (Figure 2).

- | | | |
|--|---|-------------------|
| <ul style="list-style-type: none"> (a) Axles fitted with steered wheels or self-steering wheels: <ul style="list-style-type: none"> From the front edge (towards the front of the vehicle)
(tip C at 30°) To the rear edge (towards the rear of the vehicle)
(tip A at 100 mm) | } | $R_v \leq 1,5 R$ |
| <ul style="list-style-type: none"> (b) Axles fitted with non-steered wheels: <ul style="list-style-type: none"> From the front edge (tip C at 20°) To the rear edge (tip A at 100 mm) | } | $R_v \leq 1,25 R$ |

where R is the radius of the tyre fitted to the vehicle, and R_v the distance, expressed as a radius, at which the lower edge of the outer valance is situated.

- 7.2.2. In the case of multiple axles where distance 'd' between the tyres on adjacent axles does not exceed 300 mm, the outer valances located in the space between the axles must be located at the distances set out in item 7.2.1 and must extend downwards in such a way as not to be more than 150 mm above a horizontal line passing through the centre of the wheels, or in such a way that the horizontal distance between their lower extremities does not exceed 60 mm (Figure 4a).
- 7.2.3. The depth of the outer valance must extend to not less than 45 mm, at all points behind a vertical line passing through the centre of the wheel. The depth of the valances may be gradually reduced in front of this line.
- 7.2.4. No openings enabling spray to emerge when the vehicle is moving are allowed in the outer valances or between the outer valances and the other parts of the mudguards.
- 7.3. *Rain flaps*
- 7.3.1. The width of the flap must fulfil the requirement for 'q' in item 7.1.1 (c), except where the flap is within the mudguards, in which case it must be at least equal in width to the tread of the tyre.
- 7.3.2. The orientation of the flap must be basically vertical.
- 7.3.3. The maximum height of the bottom edge must not exceed 200 mm (Figure 3).
This distance is increased to 300 mm in the case of the last axle where the radial distance of the lower edge of the outer valancing, R_v , does not exceed the dimensions of the radius of the tyres fitted to the wheels on that axle.
- 7.3.4. The rain flap must not be more than 300 mm from the rearmost edge of the tyre, measured horizontally.
- 7.3.5. In the case of multiple axles where distance 'd' between the tyres on adjacent axles is less than 250 mm, only the rear set of wheels must be fitted with rain flaps. There must be a rain flap behind each wheel when distance 'd' between the tyres on adjacent axles is at least 250 mm (Figure 4b).
- 7.3.6. Rain flaps must not be deflected by more than 100 mm towards the rear under a force of 3 N per 100 mm of flap width, applied to a point located 50 mm above the lower edge of the flaps.
- 7.3.7. The whole of the front face of the part of the rain flap having the minimum dimensions required must be fitted with a spray-suppression device that meets the specifications set out in Annex II, Appendix 1.
- 7.3.8. No openings enabling spray to emerge are allowed between the lower rear edge of the mudguard and the rain flaps.
- 7.3.9. Where the spray-suppression device meets the specifications relating to rain flaps (item 7.3), no additional rain flap is required.
8. **Requirements relating to spray-suppression systems fitted with energy-absorption spray-suppression devices for certain axles that are fitted with non-steered or self-steering wheels (see item 6.2)**
- 8.1. *Mudguards*
- 8.1.1. Mudguards must cover the zone immediately above the tyre or tyres. Their front and rear extremities must extend at least to the horizontal plane that is tangent to the upper edge of the tyre or tyres (Figure 5). However, the rear extremity may be replaced by the rain flap, in which case this must extend to the upper part of the mudguard (or equivalent component).
- 8.1.2. All of the inner rear part of the mudguard must be fitted with a spray-suppression device that meets the requirements set out in Annex II, Appendix 1.
- 8.2. *Outer valances*
- 8.2.1. In the case of single or multiple axles where the distance between the adjacent tyres is at least 250 mm, the outer valance must cover the surface extending from the lower to the upper part of the mudguard up to a straight line formed by the tangent to the upper edge of the tyre or tyres and lying between the vertical plane formed by the tangent to the front of the tyre and the mudguard or rain flap located behind the wheel or wheels (Figure 5b).
In the case of multiple axles an outer valance must be located by each wheel.
- 8.2.2. No openings enabling spray to emerge are allowed between the outer valance and the inner part of the mudguard.

- 8.2.3. Where rain flaps are not fitted behind each wheel (see item 7.3.5), the outer valance must be unbroken between the outer edge of the rain flap to the vertical plane that is tangent to the point furthest to the front of the tyre (Figure 5a) of the first axle.
- 8.2.4. The entire inner surface of the outer valance, the height of which must not be less than 100 mm, must be fitted with an energy-absorption spray-suppression device complying with the requirements of Annex II.
- 8.3. *Rain flaps*
- These flaps must extend to the lower part of the mudguard and comply with items 7.3.1 to 7.3.9.
9. **Requirements concerning spray-suppression systems fitted with air/water separator spray-suppression devices for axles with steered and non-steered wheels**
- 9.1. *Mudguards*
- 9.1.1. Mudguards must comply with the requirements of item 7.1.1 (c).
- 9.1.2. Mudguards for single or multiple axles where the distance between the tyres on adjacent axles exceeds 300 mm must also comply with item 7.1.1 (a).
- 9.1.3. In the case of multiple axles where the distance between the tyres on adjacent axles does not exceed 300 mm the mudguards must also conform to the model shown in Figure 7.
- 9.2. *Outer valances*
- 9.2.1. The lower edges of the outer valances must be fitted with air/water separator spray-suppression devices complying with the requirements of Annex II.
- 9.2.2. In the case of single or multiple axles where the distance between the tyres on adjacent axles exceeds 300 mm, the lower edge of the spray-suppression device fitted to the outer valance must have the following maximum dimensions and radii, starting from the centre of the wheel (Figures 6 and 7):
- | | | |
|---|---|-------------------|
| (a) Axles fitted with steered wheels or self-steering wheels: | } | $R_v \leq 1,05 R$ |
| from the front edge (towards the front of the vehicle) (tip C at 30°)
to the rear edge (towards the rear of the vehicle) (tip A at 100 mm) | | |
| (b) Axles fitted with non-steered wheels: | } | $R_v \leq 1,00 R$ |
| from the front edge (tip C at 20°)
to the rear edge (tip A at 100 mm) | | |
- where R = is the radius of tyre fitted to the vehicle;
 R_v = the radial distance from the lowest edge of the outer valance to the centre of the wheel.
- 9.2.3. In the case of multiple axles where the distance between the tyres on adjacent axles does not exceed 300 mm, the outer valances located in the inter-axle spaces must follow the path specified in item 9.1.3, and must extend downwards in such a way as not to be more than 100 mm above a horizontal straight line passing through the wheel centres (Figure 7).
- 9.2.4. The depth of the outer valance must extend to not less than 45 mm, at all points behind a vertical line passing through the centre of the wheel. This depth may be gradually reduced in front of this line.
- 9.2.5. No openings enabling spray to emerge are allowed in the outer valances or between the outer valances and the mudguards.
- 9.3. *Rain flaps*
- 9.3.1. Rain flaps must:
- (a) comply with item 7.3 (Figure 3); or
- (b) comply with items 7.3.1, 7.3.2, 7.3.5, 7.3.8 and 9.3.2 (Figure 6).
- 9.3.2. Spray suppression equipment complying with the specifications set out in Annex II, Appendix 2, must be fitted to the rain flaps referred to in item 9.3.1 (b), at least along the full edge.

- 9.3.2.1. The lower edge of the spray-suppression device must be not more than 200 mm from the ground.
- 9.3.2.2. The spray-suppression device must be at least 100 mm deep.
- 9.3.2.3. Apart from the lower part, which includes the spray-suppression device, the rain flap as referred to in item 9.3.1 (b) must not bend by more than 100 mm towards the rear under the effect of a force of 3 N per 100 mm of width of the rain flap measured at the intersection of the rain flap with the spray-suppression device in its working position, applied at a distance of 50 mm above the lower edge of the rain flap.
- 9.3.3. The rain flap must not be more than 200 mm from the rearmost edge of the tyre, measured horizontally.

Appendix

MODEL

(Maximum format: A4 (210 mm x 297 mm))

ANNEX TO THE EEC TYPE-APPROVAL CERTIFICATE IN RESPECT OF A TYPE OF VEHICLE WITH REGARD TO THE FITTING OF SPRAY-SUPPRESSION SYSTEMS

(Articles 4 (2) and 10 of Council Directive 70/156/EEC of 6 February 1970 on the approximation of the laws of the Member States relating to the type-approval of motor vehicles and their trailers)

e . . .

Name of Administration

EEC type-approval No: Extension No:

- 1. Trade mark or name of vehicle:
- 2. Type and trade description of vehicle:
- 3. Means of identifying type, if indicated on the vehicle:
- 3.1. Position of marking in question:
- 4. Category of vehicle:
- 5. Name and address of manufacturer:
- 6. Name and address of manufacturer's authorized representative (if any):
- 7. Characteristics of the spray-suppression devices (type, brief description, trade mark or name, component type-approval number(s):
- 8. Date vehicle submitted for EEC type-approval tests:
- 9. Technical service responsible for the EEC type-approval tests:
- 10. Date of test report issued by the technical service:
- 11. Number of test report issued by the technical service:
- 12. Reason(s) for the extension of EEC type-approval (where applicable):
- 13. EEC type-approval in respect of the fitting of spray-suppression systems has been granted/refused (1)
- 14. Place:
- 15. Date:
- 16. Signature:
- 17. Annexed: the documents making up the EEC type-approval file, and a list thereof, deposited with the competent authorities which granted that approval; a copy of some or all of the documents can be obtained on request.
- 18. Remarks (if any):

(1) Delete as appropriate.

ANNEX IV

CONFORMITY OF PRODUCTION

CESSATION OF PRODUCTION

1. Conformity of production

1.1. Any spray-suppression device bearing the EEC component type-approval mark must conform to the type that has been approved. The authority issuing the EEC type-approval mark keeps one sample which, together with the EEC component type-approval certificate, may be used to establish whether the devices marketed which bear the EEC component type-approval mark meet the stated requirements.

1.2. A type of device is defined by the model and descriptive documents lodged at the time of application for EEC component type-approval. Devices whose characteristics are identical to those of the pattern device and whose other components do not differ from those of the pattern device except for variants not affecting the properties referred to in this Annex may be considered as belonging to the same type.

1.3. The manufacturer carries out routine checks in order to guarantee the conformity of production of the type that has been approved.

To this end the manufacturer must:

- either have available a laboratory which is sufficiently well-equipped for the execution of the essential tests, or
- have the production-conformity tests carried out by an approved laboratory.

The results of the production conformity checks are made available for inspection by the competent authorities for at least one year.

1.4. The competent authorities may also conduct spot checks.

1.5. Conformity of production with the type of device that has been approved must be checked under the conditions and in accordance with the methods provided for in Annex II.

At the request of the authorities which have granted component type-approval, manufacturers shall provide them with devices of the type previously type-approved for the purpose of tests or conformity checks.

1.6. Devices are deemed to conform if 9 out of 10 samples chosen at random satisfy the requirements of section 4 of Annex II, Appendices 1 and 2.

1.7. If the condition specified in item 1.6 is not satisfied, a further 10 samples chosen at random must be examined.

The average of all measurements taken must be in conformity with the specifications of item 4 of Annex II, Appendices 1 and 2, and no individual measurement must be less than 95 % of the value specified.

2. Cessation of production

An EEC component type-approval holder ceasing production must forthwith inform the competent authorities of that fact.

FIGURES

Figure 1

Width (q) of mudguard (a) and position of valance (j)

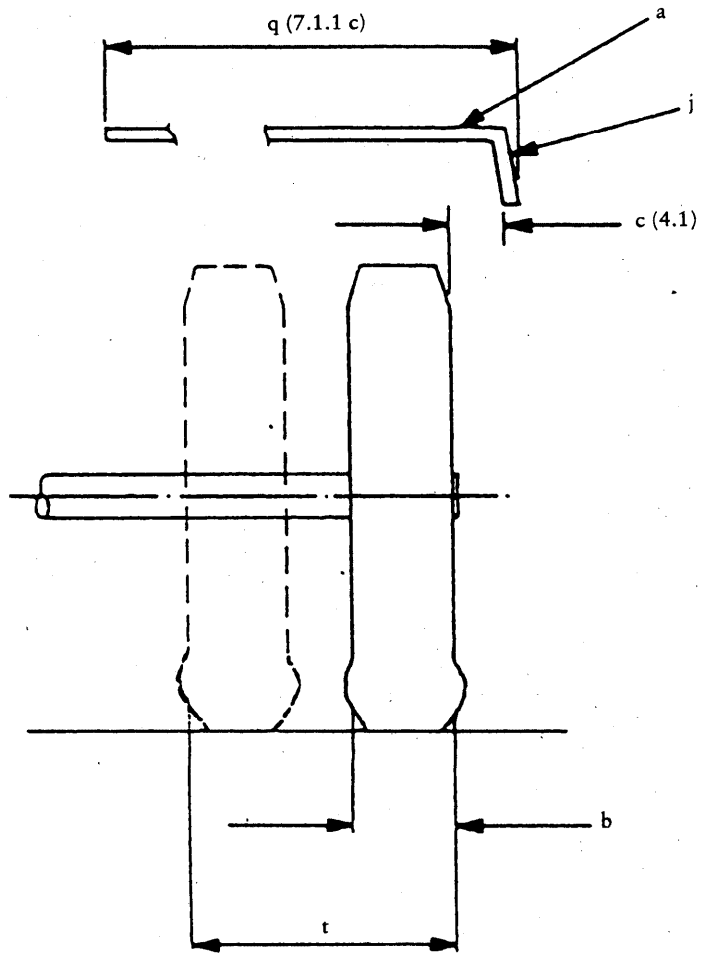

Note: The figures refer to the corresponding items in Annex III.

Figure 2

Dimensions of mudguard and outer valance

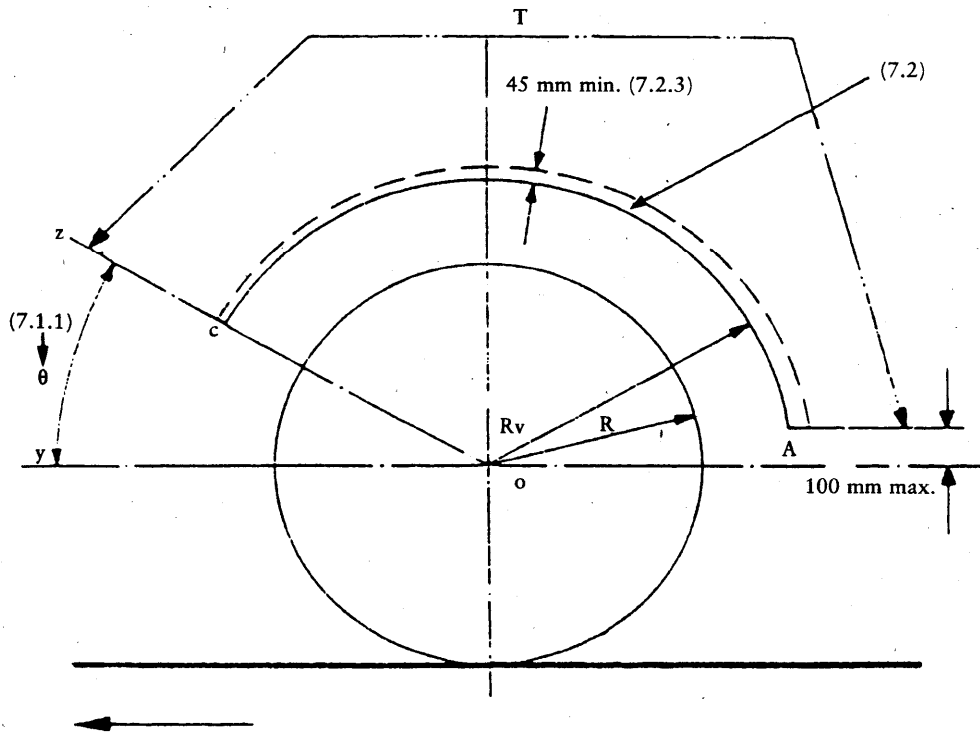

Note: 1. The figures quoted relate to the corresponding items in Annex III.
 2. T: extent of mudguard.

Figure 3

Position of mudguard and rain flap

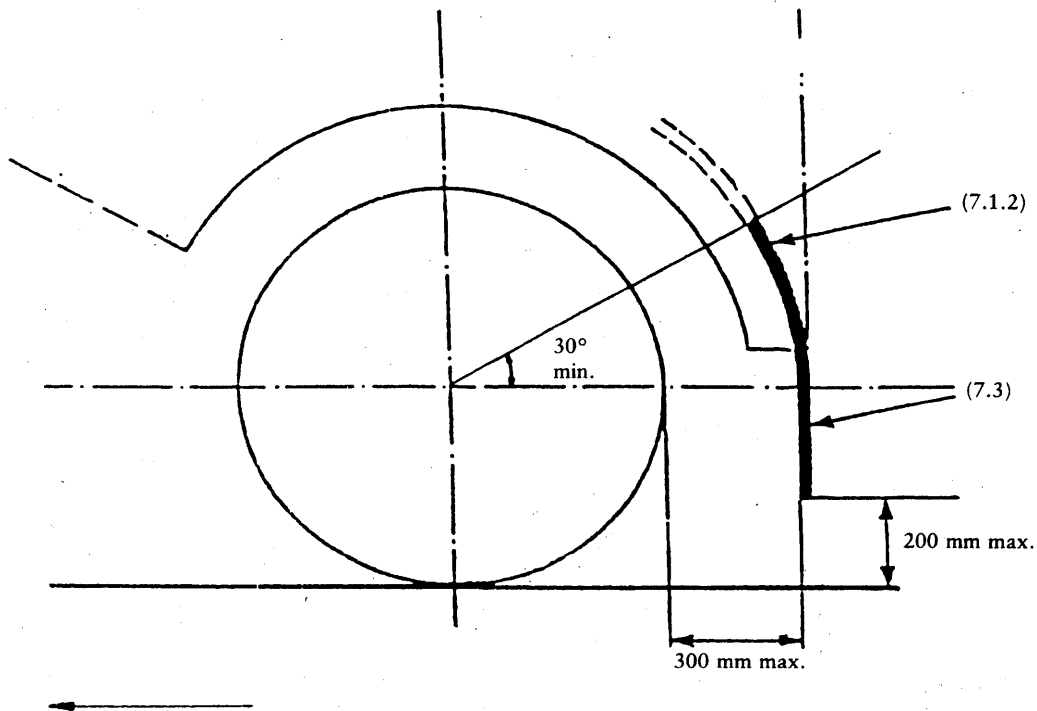

Note: The figures quoted relate to the corresponding items in Annex III.

Figure 4

Mudguards and outer valance for steered or self-steering or non-steered wheels

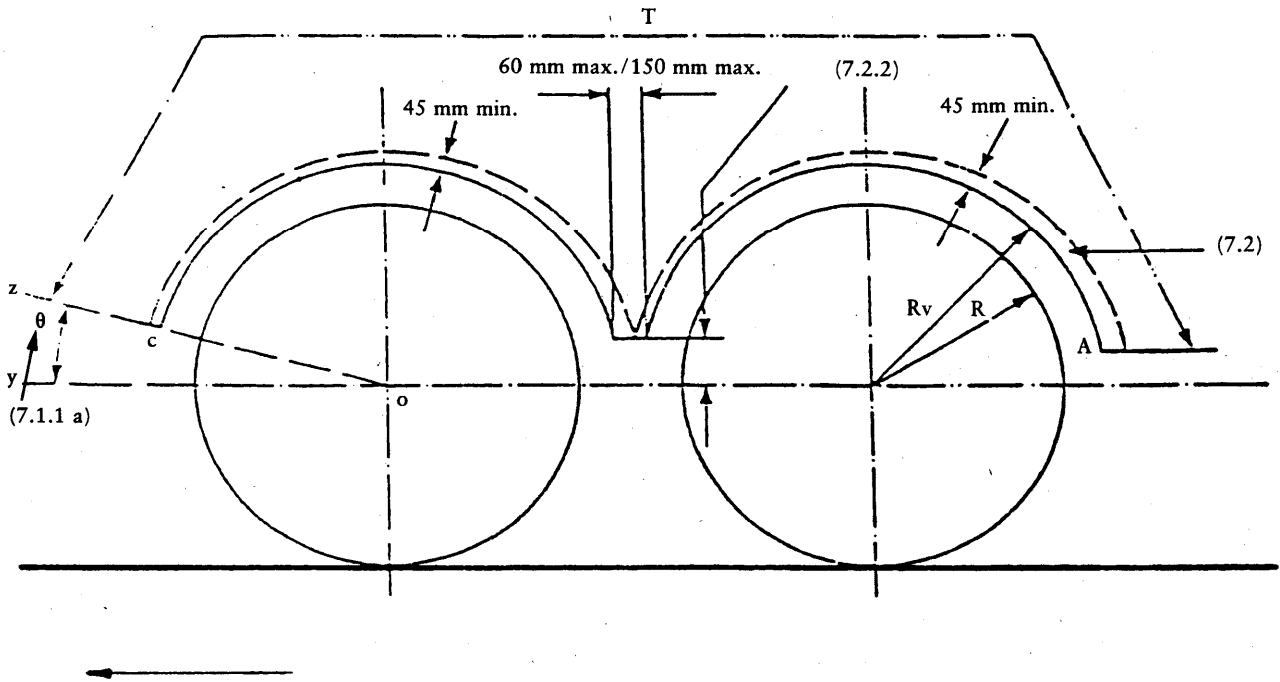

(a) Dimensions of mudguards and outer valances for multiple axles

- Note: 1. The figures quoted relate to the following items in Annex III.
 2. T: extent of mudguard.

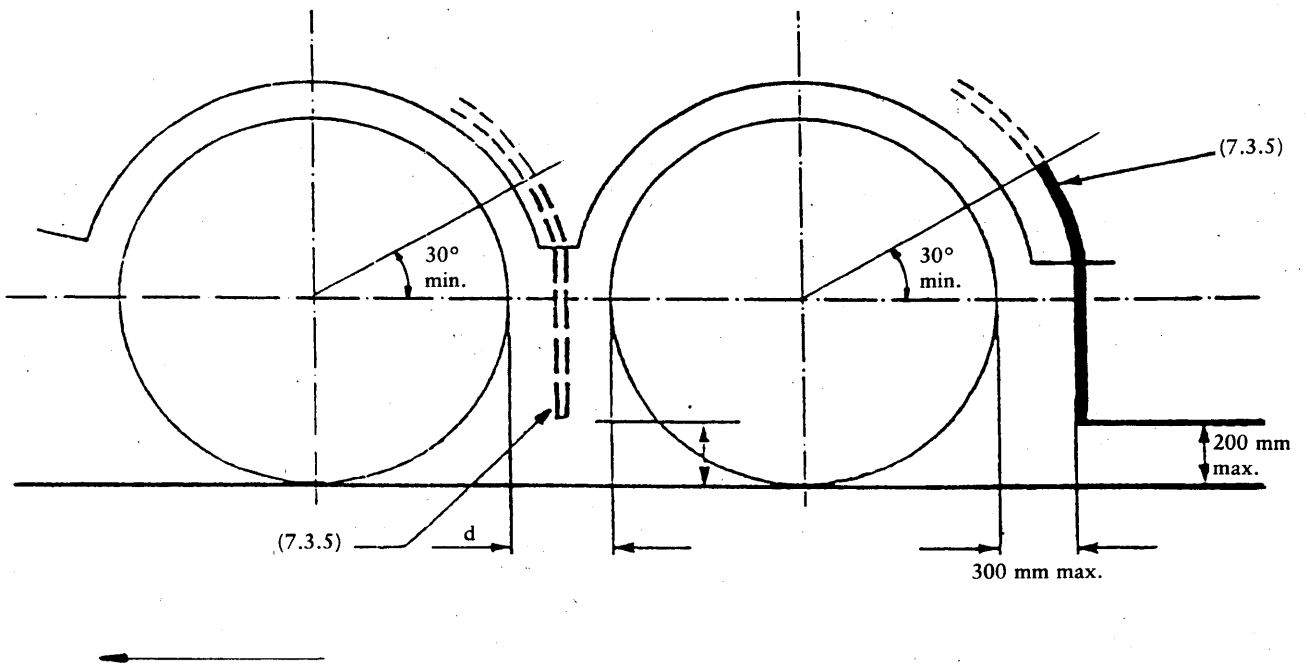

(b) Position of spray-suppression devices for multiple axles

- Note: The figures relate to the corresponding items in Annex III.

Figure 5

Diagram showing assembly of a spray-suppression system incorporating spray-suppression devices fitted with energy absorbers for axles fitted with non-steered or self-steering wheels

(Annex III — items 6.2 and 8)

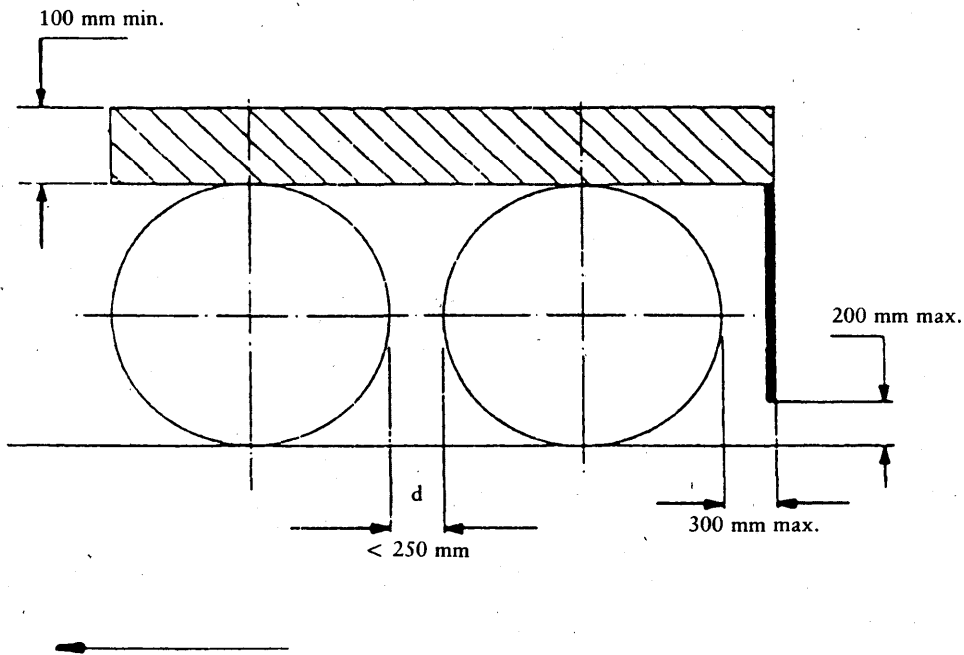

(a) Multiple axles where the distance between the tyres is less than 250 mm

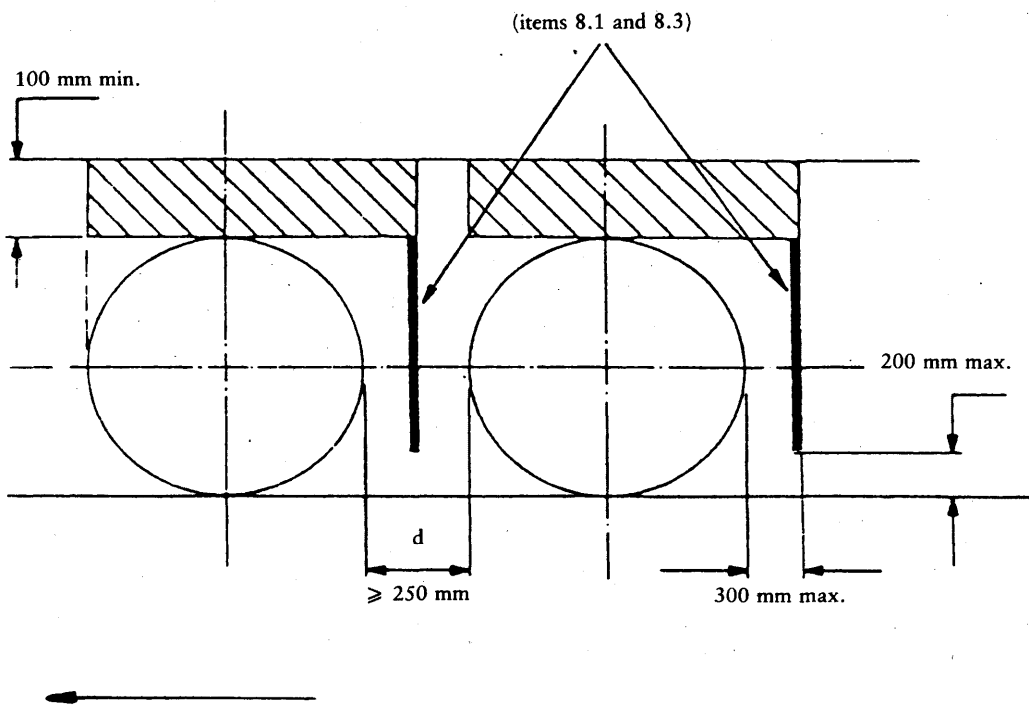

(b) Single axles or multiple axles where the distance between the tyres is not less than 250 mm

Figure 6

Diagram showing assembly of a spray-suppression system incorporating spray-suppression devices fitted with air/water separators for axles fitted with steered, self-steering or non-steered wheels

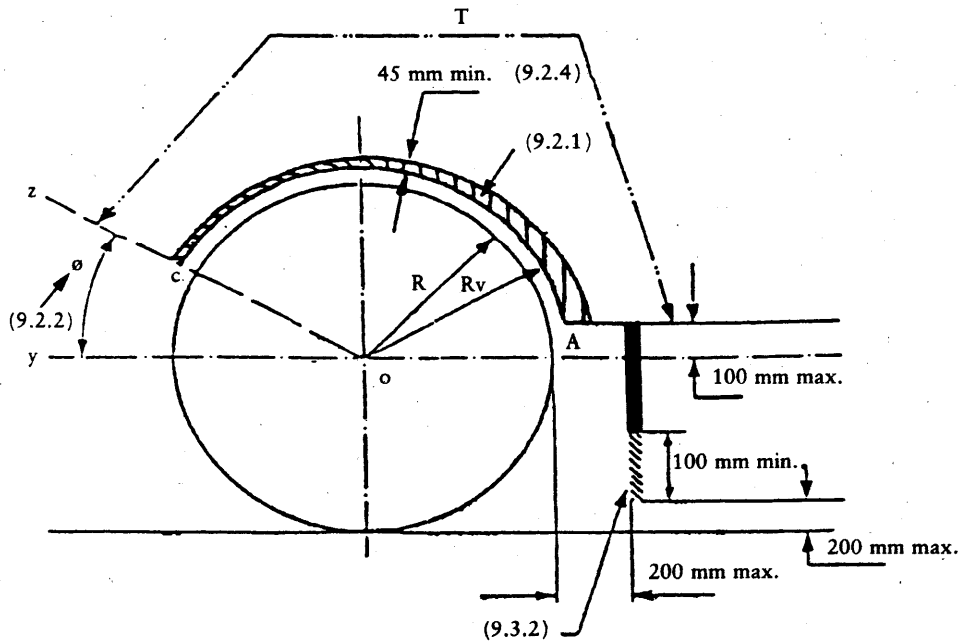

- Note: 1. The figures relate to the corresponding items in Annex III.
 2. T: extent of mudguard.

Figure 7

Diagram showing assembly of a spray-suppression system incorporating spray-suppression devices (mudguard, rain flap, outer valance) for multiple axles where the distance between the tyres does not exceed 300 mm

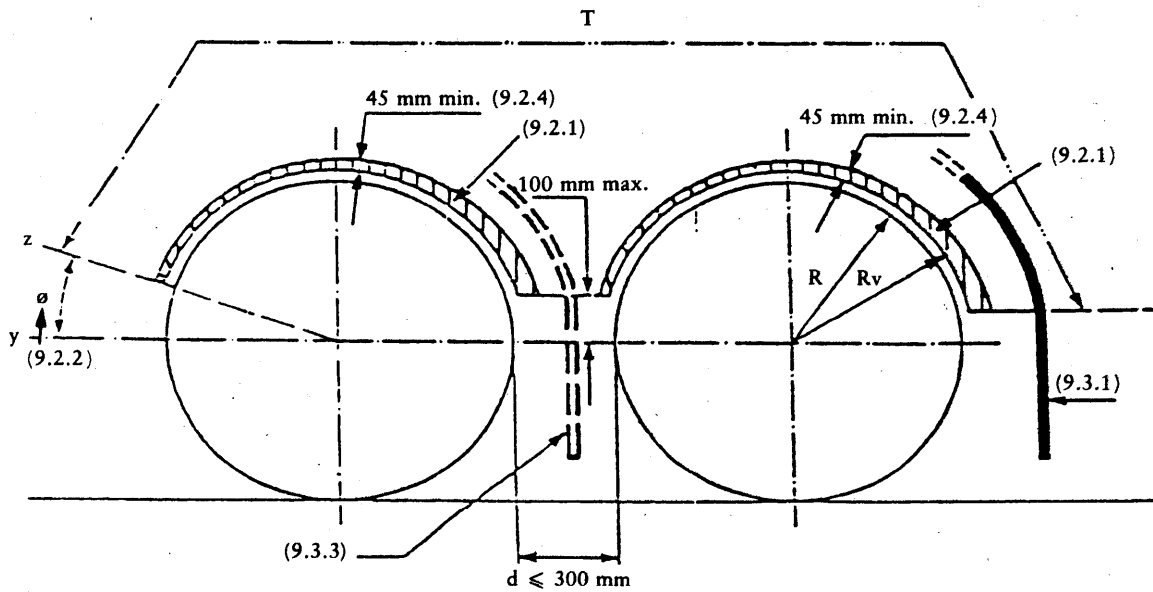

$d \geq 250$: rain flap required

- Note: 1. The figures relate to the corresponding items in Annex III.
 2. T: extent of mudguard.

Figure 8

Test assembly for energy absorption spray-suppression devices

(See Annex II, Appendix 1)

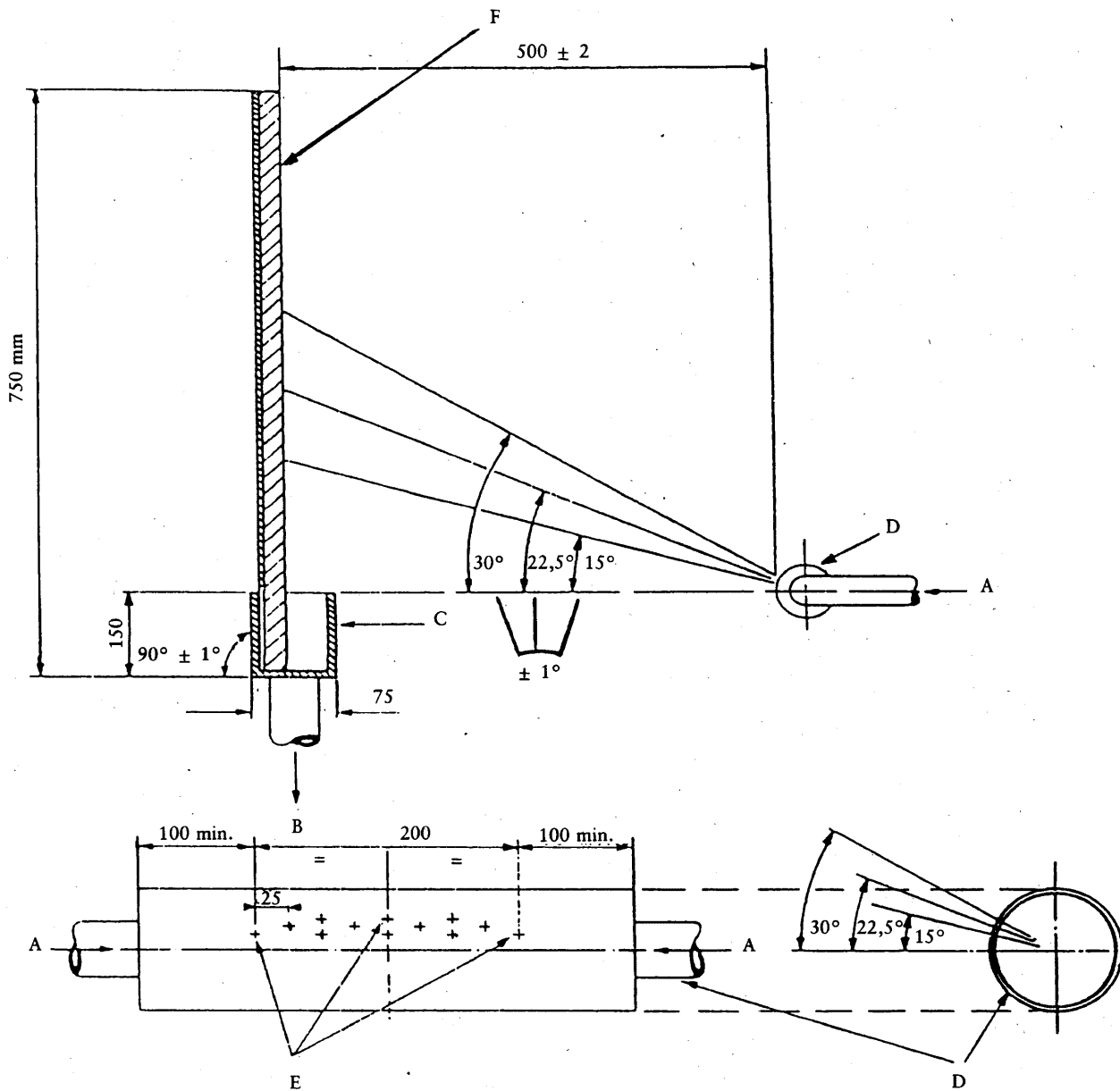

- Note: A = water supply from pump.
 B = flow towards collector tank.
 C = collector with inside dimension of $500 (+5/-0)$ mm length and $75 (+2/-0)$ mm width.
 D = thin-wall, 54 mm diameter pipe.
 E = 12 holes drilled radially as shown, diameter $1,68 (+0,025/-0)$ mm.
 F = $500 (+0/-5)$ mm-wide sample to be tested.

All linear dimensions are shown in millimetres.

Figure 9

Test assembly for air/water separator spray-suppression devices

(see Annex II, Appendix 2)

