

II

(Acts whose publication is not obligatory)

COUNCIL

COUNCIL DIRECTIVE

of 25 June 1987

on roll-over protection structures mounted in front of the driver's seat on narrow-track wheeled agricultural and forestry tractors

(87/402/EEC)

THE COUNCIL OF THE EUROPEAN COMMUNITIES,

Having regard to the Treaty establishing the European Economic Community, and in particular Article 100 thereof,

Having regard to the proposal from the Commission ⁽¹⁾,

Having regard to the opinion of the European Parliament ⁽²⁾,

Having regard to the opinion of the Economic and Social Committee ⁽³⁾,

Whereas Council Directive 74/150/EEC of 4 March 1984 on the approximation of the laws of the Member States relating to the type-approval of wheeled agricultural or forestry tractors ⁽⁴⁾, as last amended by the Act of Accession of Spain and Portugal, lays down that the necessary provisions for the implementation of the EEC type-approval procedure in respect of individual tractor parts or characteristics should be specified in special directives; whereas the provisions relating to roll-over protection structures and their attachments to tractors were laid down by Directives 77/536/EEC ⁽⁵⁾ and 79/622/EEC ⁽⁶⁾, as last amended by the Act of Accession

of Spain and Portugal; whereas these two Directives cover respectively dynamic and static testing procedures — either of which may be employed by manufacturers for the present — and relate to standard tractors, that is, tractors having a maximum ground clearance of 1 000 mm and a fixed or adjustable track width of one of the driving axles of not less than 1 150 mm and weighing between 1,5 and 4,5 tonnes in the case of tractors covered by the 'dynamic testing' directive and not less than 800 kilograms in the case of tractors covered by the 'static testing' directive;

Whereas the tractors covered by this Directive have a maximum ground clearance of 600 mm, affixed or adjustable minimum track width with one of the axles less than 1 150 mm fitted with tyres of a larger size and a mass greater than 600 but less than 3 000 kilograms; whereas the roll-over protection structures of these tractors, which are used for specific activities, can be made subject to specific requirement or requirements other than those of Directive 77/536/EEC and 79/622/EEC;

Whereas the technical requirements with which such 'narrow track' tractors must comply pursuant to national laws relate, *inter alia*, to roll-over protection structures and to their attachment to the tractor; whereas those requirements differ from one Member State to another; whereas it is therefore necessary that all Member States adopt the same requirements either in addition to, or in place of, their existing rules in order, in particular, to allow the EEC type-approval procedure which was the subject of Directive 74/150/EEC to be introduced in respect of each type of tractor;

⁽¹⁾ OJ No C 222, 2. 9. 1985, p. 1.

⁽²⁾ OJ No C 190, 20. 7. 1987.

⁽³⁾ OJ No C 169, 8. 7. 1985, p. 5.

⁽⁴⁾ OJ No L 84, 28. 3. 1974, p. 10.

⁽⁵⁾ OJ No L 220, 29. 8. 1977, p. 1.

⁽⁶⁾ OJ No L 179, 17. 7. 1979, p. 1.

Whereas this Directive covers roll-over protection structures of the dual-pillar type mounted in front of the driver's seat and characterized by a reduced zone of clearance attributable to the tractor silhouette, thus rendering it inadvisable, under any circumstances, to impede access to the driving position but worthwhile retaining these structures (fold-down or not) in view of their undoubted ease of use; whereas rear mounted roll-over protection structures of narrow track wheeled agricultural and forestry tractors have been the subject of Directive 86/298/EEC⁽¹⁾;

Whereas a harmonized component type-approval procedure for roll-over protection structures and their attachment to the tractor makes it possible for each Member State to check compliance with the common construction and testing requirements and to inform the other Member States of its findings by sending them copies of the component type-approval certificate completed for each type of roll-over protection structure and its attachment to the tractor; whereas the placing of an EEC component type-approval mark on all structures manufactured in conformity with the approved type obviates any need for technical checks on those structures in the other Member States; whereas common requirements concerning other elements and characteristics of the roll-over protection structure will be laid down at a later date;

Whereas the harmonized requirements are intended principally to ensure safety at work and safety on the road throughout the Community; whereas, for this reason, it is necessary to introduce the obligation for tractors covered by this Directive to be fitted with roll-over protection structures;

Whereas the approximation of the national laws relating to these tractors entails reciprocal recognition by Member States of the checks carried out by each of them on the basis of the common requirements,

HAS ADOPTED THIS DIRECTIVE,

Article 1

This Directive shall apply to tractors as defined in Article 1 of Directive 74/150/EEC having the following characteristics:

- ground clearance of not more than 600 mm beneath the lowest points of the front and rear axles, allowing for the differential,
- fixed or adjustable minimum track width with one of the axles less than 1 150 mm fitted with tyres of a

larger size. It is assumed that the axle mounted with the wider tyres is set at a track width of not more than 1 150 mm. It must be possible to set the track width of the other axle in such a way that the outer edges of the narrower tyres do not go beyond the outer edges of the tyres of the other axle. Where the two axles are fitted with rims and tyres of the same size, the fixed or adjustable track width of the two axles must be less than 1 150 mm,

- mass of 600 and 3 000 kilograms, corresponding to the unladen weight of the tractor as defined in section 2.4 of Annex I to Directive 74/150/EEC, including the roll-over protection structure fitted in compliance with this Directive and tyres of the largest size recommended by the manufacturer.

Article 2

1. Each Member State shall grant component type-approval for any type of roll-over protection structure and its tractor attachment which satisfies the construction and testing requirements laid down in Annexes I to IV.

2. A Member State which has granted EEC component type-approval shall take the measures required to verify, in so far as is necessary and if need be in cooperation with the competent authorities in the other Member States, that production models conform to the approved type. Such verification shall be limited to spot checks.

Article 3

Member States shall, for each type of roll-over protection structure and its tractor attachment which they approve pursuant to Article 2, issue to the manufacturer of the tractor or of the roll-over protection structure, or to his authorized representative, an EEC component type-approval mark conforming to the model shown in Annex VII.

Member States shall take all appropriate measures to prevent the use of marks liable to create confusion between roll-over protection structures which have been component type-approved pursuant to Article 2 and other devices.

Article 4

1. No Member State may prohibit the placing on the market of roll-over protection structures or their tractor attachments on grounds relating to their construction if they bear the EEC component type-approval mark.

2. Nevertheless, a Member State may prohibit the placing on the market of roll-over protection structures bearing the

⁽¹⁾ OJ No L 186, 8. 7. 1986, p. 26.

EEC component type-approval mark which fail to conform to the approved type.

That State shall forthwith inform the other Member States and the Commission of the measures taken, specifying the reasons for its decision.

Article 5

The competent authorities of each Member State shall within one month send to the competent authorities of the other Member States copies of the component type-approval certificates, an example of which is given in Annex VIII, completed for each type of roll-over protection structure which they approve or refuse to approve.

Article 6

1. If the Member State which has granted EEC component type-approval finds that a number of roll-over protection structures and their tractor attachments bearing the same EEC component type-approval mark do not conform to the type which it has approved, it shall take the necessary measures to ensure that production models conform to the approved type. The competent authorities of that State shall advise those of the other Member States of the measures taken which may, where there is serious and repeated failure to conform, extend to withdrawal of EEC component type-approval. The said authorities shall take the same measures if they are informed by the competent authorities of another Member State of such failure to conform.

2. The competent authorities of the Member States shall within one month inform each other of any withdrawal of EEC component type-approval and of the reasons for any such measure.

Article 7

Any decision taken pursuant to the provisions adopted in implementation of this Directive to refuse or withdraw component type-approval for roll-over protection structures and their tractor attachments, or to prohibit their placing on the market or their use, shall set out in detail the reasons on which it is based. Such decision shall be notified to the party concerned, who shall at the same time be informed of the remedies available to him under the laws in force in the Member States and of the time limits allowed for the exercise of such remedies.

Article 8

No Member State may refuse to grant EEC type-approval or national type-approval in respect of a tractor on grounds relating to the roll-over protection structure or its tractor

attachment if these bear the EEC component type-approval mark and if the requirements laid down in Annex IX have been satisfied.

Article 9

1. No Member State may refuse or prohibit the sale, registration, entry into service or use of any tractor on grounds relating to the roll-over protection structure and its tractor attachment if these bear the EEC component type-approval mark and if the requirements laid down in Annex IX have been met.

However, Member States may, in compliance with the Treaty, impose restrictions on the use of tractors referred to in this Directive in certain areas where safety so dictates, owing to the specific nature of certain terrains or crops. Member States shall inform the Commission of any such restrictions before they are implemented and of the reasons for their adoption.

2. This Directive shall not affect the right of Member States to specify — in due compliance with the Treaty — the requirements they deem necessary to ensure that workers are protected when using the tractors in question, provided this does not mean that the protection structures are modified in a way unspecified in this Directive.

Article 10

1. In connection with EEC type-approval, any tractor to which Article 1 refers must be fitted with a roll-over protection structure.

2. The structure, referred to in paragraph 1, unless it is a rear-mounted protection structure, must comply with the requirements laid down in Annexes I to V to this Directive, or in Directives 77/536/EEC or 79/622/EEC.

Article 11

Any amendments which are necessary in order to adapt the requirements of the Annexes to this Directive so as to take account of technical progress shall be adopted in accordance with the procedure laid down in Article 13 of Directive 74/150/EEC.

Article 12

Within 18 months following notification of this Directive, the Council, acting on a proposal from the Commission, on the basis of the provisions of the Treaty, shall adopt a Directive supplementing this Directive with provisions introducing additional impact tests into the dynamic test procedure.

Article 13

1. Member States shall bring into force the provisions necessary to comply with this Directive within 24 months of its notification⁽¹⁾ and shall forthwith inform the Commission thereof.

2. Member States shall communicate to the Commission the texts of the main provisions of national law which they adopt in the field covered by this Directive.

Article 14

This Directive is addressed to the Member States.

Done at Luxembourg, 25 June 1987.

For the Council

The President

H. DE CROO

⁽¹⁾ This Directive was notified to the Member States on 26 June 1987.

ANNEX I

CONDITIONS FOR EEC COMPONENT TYPE-APPROVAL

1. DEFINITION

- 1.1. 'Roll-over protection structure', hereinafter called 'protection structure', means the structure on a tractor the essential purpose of which is to avoid or limit risks to the driver resulting from roll-over of the tractor during normal use.
- 1.2. The structures mentioned in 1.1 display the following characteristics:
- the principal structures are mounted in front of the centre of the steering wheel,
 - the structures have a zone of clearance as defined in Annex IV-A, section 2.

2. GENERAL REQUIREMENTS

- 2.1. Every protection structure and its attachment to a tractor must be so designed and constructed as to fulfil the essential purpose laid down in section 1.1.
- 2.2. This condition is considered to be fulfilled if the requirements of Annexes II, III and IV are complied with.

3. APPLICATION FOR EEC COMPONENT TYPE-APPROVAL

- 3.1. The application for EEC component type-approval with regard to the strength of a protection structure and the strength of its attachment to a tractor must be submitted by the tractor manufacturer or by the manufacturer of the protection structure or by their authorized representatives.
- 3.2. The application must be accompanied by the undermentioned documents in triplicate and by the following particulars:
- a drawing, either to scale or with indication of the principal dimensions, showing the general arrangement of the protection structure. This drawing must, in particular, show details of the mounting components,
 - photographs from side and front showing mounting details,
 - a brief description of the protection structure, including type of construction, method of mounting on the tractor and, where necessary, details of cladding and interior padding,
 - details of materials used in the structure and in the roll-over protection structure mountings (see Annex VI).
- 3.3. A tractor representative of the tractor type for which the protection structure to be approved is intended must be submitted to the technical service responsible for conducting the component type-approval tests. This tractor must be equipped with the protection structure.

Furthermore, the manufacturer must indicate the sizes of tyres fitting or able to fit the front and rear axles.

- 3.4. The holder of EEC component type-approval may request its extension to other tractor types. The competent authority which has granted the original EEC component type-approval must grant the extension if the approved protection structure and the type(s) of tractor for which the extension is requested comply with the following conditions:
- the mass of the unballasted tractor, as defined in section 1.4 of Annex III, does not exceed by more than 5 % the reference mass used in the test;
 - the method of attachment and the points of attachment to the tractor are identical,

- any components such as mudguards and bonnet which may provide support for the protection structure have identical strength and are identically situated with respect to the protection structure,
- the critical dimensions and the position of the seat and steering wheel relative to the protection structure, and the position relative to the protection structure of the points deemed rigid and taken into consideration for the purpose of verifying that the zone of clearance is protected, are such that the zone of clearance continues to be protected by the structure after the latter has undergone the deformation resulting from the various tests.

4. MARKINGS

- 4.1. Every protection structure conforming to the approved type must bear the following markings:
 - 4.1.1. The trade mark or name;
 - 4.1.2. A component type-approval mark conforming to the model in Annex VII;
 - 4.1.3. Serial number of the protection structure;
 - 4.1.4. Make and type(s) of tractor(s) for which the protection structure is intended.
- 4.2. All these particulars must appear on a small plate.
- 4.3. These markings must be visible, legible and indelible.

ANNEX II

PRIOR CONDITIONS FOR THE STRENGTH TESTS LAID DOWN IN ANNEXES III AND IV

1. PREPARATION FOR THE PRELIMINARY TEST

The tractor must be equipped with the protection structure in its safety position. The tractor must be fitted with tyres having the greatest diameter indicated by the manufacturer and the smallest cross-section for tyres of that diameter. The tyres must not be liquid-ballasted and must be inflated to the pressure recommended for field work.

The rear wheels must be set to the narrowest track width; the front wheels must be set as closely as possible to the same track width. If it is possible to have two front track settings which differ equally from the narrowest rear track setting, the wider of these two front track settings must be selected.

All the tractor's tanks must be filled or the liquids must be replaced by an equivalent mass in the corresponding position.

2. LATERAL STABILITY TEST

Place the tractor, prepared as specified above, on a horizontal plane so that the tractor front-axle pivot point or, in the case of an articulated tractor, the horizontal pivot point between the two axles can move freely.

Using any appropriate means, such as a jack or a hoist, tilt the part of the tractor which is rigidly connected to the axle that bears more than 50 % of the tractor's weight, while constantly measuring the angle of inclination. This angle must be at least 38° at the moment when the tractor is resting in a state of unstable equilibrium on the wheels touching the ground.

Perform the test once with the steering wheel turned to full right lock and once with the steering wheel turned to full left lock.

3. NON-CONTINUOUS ROLLING TEST

3.1. General remarks

This test is intended to check whether a structure fitted to the tractor for the protection of the driver can satisfactorily prevent continuous roll-over of the tractor in the event of its overturning laterally on a slope with a gradient of 1 in 1,5.

Evidence of non-continuous rolling can be provided in accordance with one of the two methods described in 3.2 and 3.3 below.

3.2. Demonstration of non-continuous rolling behaviour by means of the overturning test

The overturning test must be carried out on a test slope at least four metres long (see Annex V, Figure 1). The surface must be covered with an 18 cm layer of a material which — measured in accordance with ASAE Recommendation No R 313, section 1 has a cone penetration index of A (235 ± 20) or B (335 ± 20).

The tractor is tilted laterally with zero initial speed; for this purpose it is placed at the start of the test slope in such a way that the wheels on the downhill side rest on the slope and the tractor's medium plane is parallel with the contour lines.

After striking the surface of the test slope, the tractor may lift itself from the surface by pivoting about the upper corner of the protection structure, but it must not roll over. It must fall back on the side which it first struck.

3.3. Demonstration of non-continuous rolling behaviour by calculation

3.3.1. For the purpose of verifying non-continuous rolling behaviour by calculation, the following characteristic tractor data must be ascertained (see Figure in Appendix 2):

H 1 (m): Height of centre of gravity.

L 3 (m): Horizontal distance between the centre of gravity and rear axle.

L 2 (m):	Horizontal distance between the centre of gravity and the front axle.
D 3 (m):	Height of rear tyres.
D 2 (m):	Height of front tyres.
H 6 (m):	Overall height (point-of-impact height).
L 6 (m):	Horizontal distance between the centre of gravity and the leading point of intersection of the protection structure (to be preceded by a minus sign if this point lies in front of the plane of the centre of gravity).
B 6 (m):	Width of protection structure.
H 7 (m):	Height of engine bonnet.
B 7 (m):	Width of engine bonnet.
L 7 (m):	Horizontal distance between the centre of gravity and the front corner of the engine bonnet.
H 0 (m):	Height of the front-axle pivot point.
S (m):	Rear track width.
B 0 (m):	Rear tyre width.
D 0 (rad):	Front-axle swing angle (from zero position to end of travel).
M (kg):	Tractor mass.
Q (kgm ²):	Moment of inertia about the longitudinal axis through the centre of gravity.

The sum of the track width S and tyre B 0 must be greater than the width B 6 of the protection structure.

3.3.2. For the purposes of calculation, the following simplifying assumptions can be made:

- the stationary tractor overturns on a slope with a 1 in 1,5 gradient with a balanced front axle, as soon as the centre of gravity is vertically above the axis of rotation,
- the axis of rotation is parallel to the tractor's longitudinal axis and passes through the centre of the contact surfaces of the downhill front and rear wheel,
- the tractor does not slide downhill,
- impact on the slope is partly elastic, with a coefficient of elasticity of $U = 0,2$,
- the depth of penetration into the slope and the deformation of the protection structure together amount to $T = 0,2$ m,
- no other components of the tractor penetrate into the slope.

4. CONDITIONS GOVERNING STRENGTH TESTS

The protection structure may only be subjected to the strength tests described in Annexes III and IV if both of the tests described in sections 2 and 3 of the present Annex have been satisfactorily completed.

Appendix 1

Flow diagram for determining the continuous roll-over behaviour of a laterally overturning tractor with a front, centre or rear-mounted roll-over protection structure (ROPS)

Version B1: Point of impact of ROPS behind longitudinally unstable equilibrium point

Version B2: Point of impact of ROPS near longitudinally unstable equilibrium point

Version B3: Point of impact of ROPS in front of longitudinally unstable equilibrium point

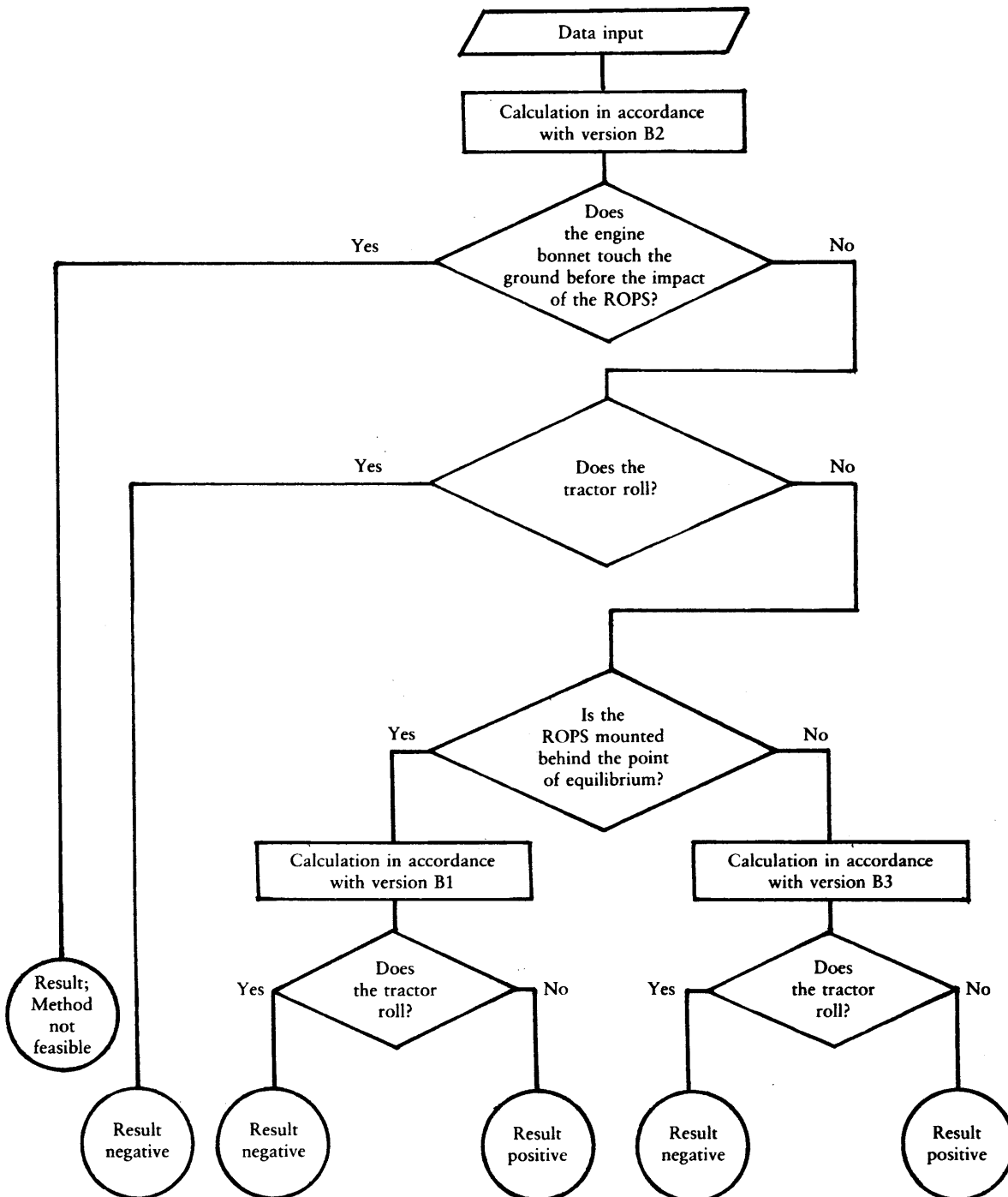

Appendix 2

Figures relating to non-continuous roll-over

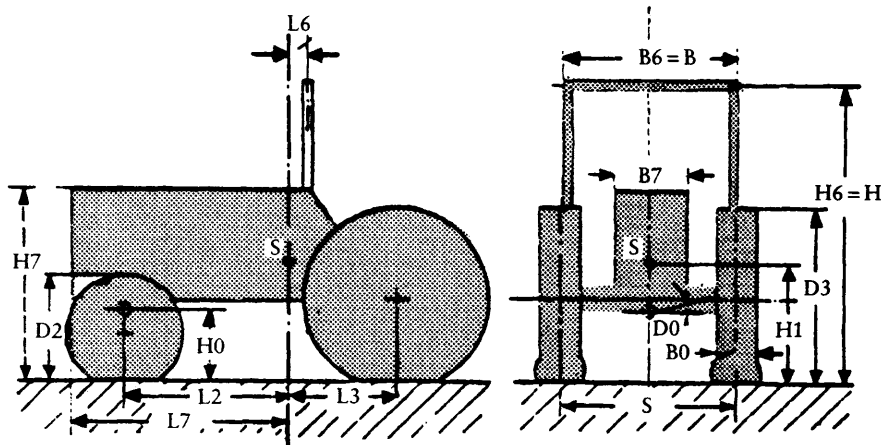

Mass M kg
Front tyres v
Rear tyres h
Moment of inertia Q kgm ²

Data required for calculating the overturn of a tractor with triaxial rolling behaviour.

ANNEX III

CONDITIONS FOR TESTING THE STRENGTH OF PROTECTION STRUCTURES AND OF THEIR ATTACHMENT TO TRACTORS

1. GENERAL REQUIREMENTS

1.1. Test purposes

Tests made using special rigs are intended to simulate such loads as are imposed on a protection structure, when the tractor overturns. These tests, described in Annex IV, enable observations to be made on the strength of the protection structure and any brackets attaching it to the tractor and any parts of the tractor which transmit the test load.

1.2. Test methods

Tests may be performed in accordance with the dynamic procedure (see Annexes III A and IV A) or the static procedure (see Annexes III B and IV B), the choice being left to the manufacturer.

The two methods are equivalent.

1.3. General rules governing preparation for tests

1.3.1. The protection structure must conform to the series production specifications. It must be attached in accordance with the manufacturer's recommended method to one of the tractors for which it is designed.

A complete tractor is not required for the static strength test; however, the protection structure and parts of the tractor to which it is attached represent an operating installation, hereinafter referred to as 'the assembly'.

1.3.2. For both the static test and the dynamic test the tractor as assembled must be fitted with all series production components which may affect the strength of the protection structure or which may be necessary for the strength test.

Components which may create a hazard in the zone of clearance must also be fitted so that they may be examined to see whether the requirements of 3.1 and 3.2 of this Annex have been fulfilled.

All components of the tractor or the protection structure including weather protection must be supplied or described on drawings.

1.3.3. For the strength test, all panels and detachable non-structural components must be removed so that they may not contribute to the strengthening of the protection structure.

1.3.4. Track width

The track width must be adjusted so that the protection structure will as far as possible not be supported by the tyres during the strength tests. If these tests are conducted in accordance with the static procedure, it must be possible to remove the wheels.

1.4. Tractor reference mass

The reference mass m_r , used in the formulae (see Annexes IV A and IV B) to calculate the height of the fall of the pendulum block, the loading energies and the crushing forces, must be at least that defined in section 2.4 of Annex I to Council Directive 74/150/EEC (i.e., excluding optional accessories but including coolant, oils, fuel, tools and driver) plus the protection structure and less 75 kilograms. Not included are optional front or rear weights, tyre ballast, mounted implements, mounted equipment or any specialized components.

2. TESTS

2.1. Sequence of tests

The sequence of tests is as follows, without prejudice to the additional tests mentioned in sections 1.6 of Annex IV A and 1.6/1.7 of Annex IV B:

- 2.1.1. Impact (dynamic tests) or loading (static test) at the rear of the structure (see section 1.1 of Annexes IV A and IV B).
- 2.1.2. Rear crushing test (dynamic or static tests) (see section 1.4 of Annexes IV A and IV B).
- 2.1.3. Impact (dynamic tests) or loading (static tests) at the front of the structure (see section 1.2 of Annexes IV A and IV B).
- 2.1.4. Impact (dynamic tests) or loading (static tests) at the side of the structure (see section 1.3 of Annexes IV A and IV B).
- 2.1.5. Crushing at the front of the structure (dynamic or static tests) (see section 1.5 of Annexes IV A and IV B).
- 2.2. **General requirements**
 - 2.2.1. If, during the test, any part of the restraining equipment breaks or moves, the test must be restarted.
 - 2.2.2. No repairs or adjustments of the tractor or protection structure may be carried out during the tests.
 - 2.2.3. The tractor gear box must be in neutral and the brakes off during the tests.
 - 2.2.4. If the tractor is fitted with a suspension system, between the tractor body and the wheels, it must be blocked during the tests.
 - 2.2.5. The side chosen for application of the first impact on the rear of the structure (in the case of dynamic tests) or the first load on the rear of the structure (in the case of static tests) must be that which, in the opinion of the testing authorities, will result in the application of the series of impacts or loads under the most unfavourable conditions for the structure. The side impact or load and the rear impact or load must be applied on both sides of the median longitudinal plane of the protection structure. The front impact or load must be applied on the same side of the median longitudinal plane of the protection structure as the side impact or load.
- 2.3. **Measurement tolerances**
 - 2.3.1. Linear dimensions: ± 3 mm
except for:
 - tyre deflection: ± 1 mm,
 - structure deflection during horizontal loadings: ± 1 mm,
 - each of the two measurements for the height of fall of the pendulum block: ± 1 mm
 - 2.3.2. Masses: ± 1 %
 - 2.3.3. Forces: ± 2 %
 - 2.3.4. Angles: ± 2 degrees.
3. **ACCEPTANCE CONDITIONS**
 - 3.1. A protection structure submitted for EEC component type-approval is regarded as having satisfied the strength requirements if it fulfils the following conditions:
 - 3.1.1. After each part-test it must be free from cracks or tears within the meaning of section 3.1 of Annexes IV A and IV B. If, during one of the tests, significant cracks or tears appear, an additional test, in accordance with Annex IV A or Annex IV B must be applied immediately.

- 3.1.2. During the tests, no part of the protection structure must enter the zone of clearance as defined in section 2 of Annexes IV A and IV B.
- 3.1.3. During the tests no part of the zone of clearance must be outside the protection of the structure, in accordance with section 3.2 of Annexes IV A and IV B.
- 3.1.4. The elastic deflection, measured in accordance with section 3.3 of Annexes IV and IV B, must be less than 250 mm.
- 3.2. There must be no accessories presenting a hazard for the driver. There must be no projecting accessory or part which is liable to injure the driver should the tractor overturn, or any accessory or part which is liable to trap him — for example by the leg or the foot — as a result of the deflections of the structure.

4. TEST REPORT

- 4.1. The test report is attached to the EEC component type-approval certificate referred to in Annex VIII.

The presentation of the report is as shown in Annex VI.

The report must include:

- 4.1.1. A general description of the protection structure's shape and construction (normally at least a scale of 1:20 for the general drawings and 1:2,5 for drawing of the attachments). The main dimensions must figure on the drawings; external dimensions of tractor with protection structure fitted; main interior dimensions and details of provisions for normal entry and exit and for escape where appropriate; and details of heating and ventilation system, where appropriate.
- 4.1.3. A brief description of any interior padding.
- 4.2. The report must identify clearly the tractor type (make, type, trade-name, etc.) used for testing and the types for which the protection structure is intended.
- 4.3. If EEC component type-approval is being extended to other tractor types, the report must include the exact reference of the report of the original EEC component type-approval as well as precise indications regarding the requirements laid down in section 3.4 of Annex I.

A. Apparatus and equipment for dynamic tests

1. PENDULUM BLOCK

- 1.1. A pendulum block must be suspended by two chains or wire ropes from pivot points not less than six metres above the ground. Means must be provided for adjusting independently the suspended height of the block and the angle between the block and the supporting chains or wire ropes.
- 1.2. The mass must be $2\,000 \pm 20$ kilograms excluding the mass of the chains or wire ropes which themselves must not exceed 100 kilograms. The length of the sides of the impact face must be 680 ± 20 mm (see Figure 4, of Annex V). The block must be filled in such a way that the position of its centre of gravity is constant and coincides with the geometrical centre of the parallelepiped.
- 1.3. The parallelepiped must be connected to the system which pulls it backwards by an instantaneous release mechanism which is so designed and located as to enable the pendulum block to be released without causing the parallelepiped to oscillate about its horizontal axis perpendicular to the pendulum's plane of oscillation.

2. PENDULUM SUPPORTS

The pendulum pivot points must be rigidly fixed so that their displacement in any direction does not exceed 1 % of the height of fall.

3. LASHINGS

- 3.1. Anchoring rails with the requisite track width and covering the necessary area for lashing the tractor in all the cases illustrated (see Figures 5, 6, and 7, Annex V) must be rigidly attached to a non-yielding base beneath the pendulum.
- 3.2. The tractor must be lashed to the rails by means of wire rope with round strand, fibre core, construction 6 × 19 in accordance with ISO 2408 and a nominal diameter of 13 mm. The metal strands must have an ultimate tensile strength of 1 770 MPa.
- 3.3. The central pivot of an articulated tractor must be supported and lashed down as appropriate for all tests. For the side impact test, the pivot must also be propped from the side opposite the impact. The front and rear wheels need not be in line if this facilitates the attachment of the wire ropes in the appropriate manner.

4. WHEEL PROP AND BEAM

- 4.1. A softwood beam of 150 mm square must be used as a prop for the wheels during the impact tests (see Figures 5, 6 and 7, Annex V).
- 4.2. A softwood beam must be clamped to the floor to brace the rim of the wheel opposite the side impact as shown in Figure 7, Annex V.

5. PROPS AND LASHINGS FOR ARTICULATED TRACTORS

- 5.1. Additional props and lashings must be used for articulated tractors. Their purpose is to ensure that the section of the tractor on which the protection structure is fitted is as rigid as that of a rigid tractor.
- 5.2. Additional specific details are given in Annex IV A for the impact and crushing tests.

6. TYRE PRESSURES AND DEFLECTIONS

- 6.1. The tractor tyres must not be liquid-ballasted and must be inflated to the pressures prescribed by the tractor manufacturer for field work.
- 6.2. The lashings must be tensioned in each particular case that the tyres undergo a deflection equal to 12 % of the tyre wall height before tensioning.

7. CRUSHING RIG

A rig as shown in Figure 8, Annex V, must be capable of exerting a downward force on a protection structure through a rigid beam approximately 250 mm wide connected to the load-applying mechanism by means of universal joints. Suitable axle stands must be provided so that the tractor tyres do not bear the crushing force.

8. MEASURING APPARATUS

- 8.1. A device such as that illustrated in Annex V, Figure 9, for measuring the elastic deflection (the difference between the maximum momentary deflection and the permanent deflection).
- 8.2. A device for checking that the protection structure has not entered the zone of clearance and that the latter has remained within the structure's protection during the test (see section 3.2 of Annex IVA).

B. Apparatus and equipment for static tests**1. STATIC TESTING RIG**

- 1.1. The static testing rig must be designed in such a way as to permit thrusts or 'loads' to be applied to the protection structure.
- 1.2. Provision must be made so that the load can be uniformly distributed normal to the direction of loading and along a flange having a length of one of the exact multiples of 50 between 250 and 700 mm. The stiff flange must have a vertical face dimension of 150 mm. The edges of the flange in contact with the protection structure must be curved with a maximum radius of 50 mm.
- 1.3. The pad must be capable of being adjusted to any angle in relation to the load direction, in order to be able to follow the angular variations of the structure's load-bearing surface as the structure deflects.
- 1.4. Direction of loading (deviation from horizontal and from vertical):
 - at start of test, under zero load: $\pm 2^\circ$
 - during test, under load: 10° above and 20° below the horizontal.These variations must be kept to a minimum.
- 1.5. The deflection rate must be sufficiently slow (less than 5 mm/s) for the load at all moments to be considered as 'static'.

2. APPARATUS FOR MEASURING THE ENERGY ABSORBED BY THE STRUCTURE

- 2.1. The 'force versus deflection' curve must be plotted in order to determine the energy absorbed by the structure. There is no need to measure the force and deflection at the point where the load is applied to the structure; however, 'force' and 'deflection' must be measured simultaneously and co-linearly.
- 2.2. The point of origin of deflection measurements must be selected so as to take account only of the energy absorbed by the structure and/or by the deflection of certain parts of the tractor. The energy absorbed by the deflection and/or the slipping of the anchoring must be ignored.

3. MEANS OF ANCHORING THE TRACTOR TO THE GROUND

- 3.1. Anchoring rails with the requisite track width and covering the necessary area for anchoring the tractor in all the cases illustrated must be rigidly attached to a non-yielding base near the testing rig.
- 3.2. The tractor must be anchored to the rails by any suitable means (plates, wedges, wire ropes, jacks, etc.) so that it cannot move during the tests. This requirement must be checked during the test, by means of the usual devices for measuring length.

If the tractor moves, the entire test must be repeated, unless the system for measuring the deflections taken into account for plotting the 'force versus deflection' curve is connected to the tractor.

4. CRUSHING RIG

- 4.1. A rig as shown in Figure 8 of Annex V must be capable of exerting a downward force on a protection structure through a rigid beam approximately 250 mm wide connected to the load-applying mechanism by means of universal joints. Suitable axle stand must be provided so that the tractor tyres do not bear crushing force.

5. OTHER MEASURING APPARATUS

- 5.1. A device such as that illustrated in Figure 9 of Annex V, for measuring the elastic deflection (the difference between the maximum momentary deflection and the permanent deflection).
- 5.2. A device for checking that the protection structure has not entered the zone of clearance and that the latter has remained within the structure's protection during the test (see section 3.2 of Annex IV B).

C. Symbols

m_1 (kg):	tractor reference mass, as defined in section 1.4 of this Annex.
$D_{(mm)}$:	deflection of the structure at the point of impact (dynamic tests) or at the point of, and in line with, the load application (static tests).
$H_{(mm)}$:	falling height of the pendulum block.
F (N) (Newton):	static load force.
F_{max} :	maximum static load force occurring during loading, (N) with the exception of the overload.
F' (N):	loading force corresponding to E'_i
F-D:	force/deflection diagram.
E_{is} (J) (Joule):	energy input to be absorbed during side loading.
E_{ii} (J):	energy input to be absorbed during longitudinal loading.
F_v (N):	vertical crushing force.
E_i (J):	strain energy absorbed. Area under F-D curve (see Figure 10a, Annex V).
E'_i (J):	strain energy absorbed after additional loading following a crack or tear (see Figures 10b and 10c, Annex V).
E_a (J):	strain energy absorbed at point when load is removed. Area contained within F-D curve (see Figure 10b, Annex V).
E''_i (J):	strain energy absorbed in overload test in the event of the load having been removed before starting this overload test. Area under F-D curve (see Figure 10c, Annex V).

ANNEX IV

TEST PROCEDURES

A. Dynamic tests

1. IMPACT AND CRUSHING TESTS

1.1. Impact at the rear

- 1.1.1. The tractor must be so placed in relation to the pendulum block that the block will strike the protection structure when the impact face of the block and the supporting chains or wire ropes are at an angle with the vertical plane equal to $m_1/100$ with a 20° maximum, unless, during deflection, the protection structure at the point of contact forms a greater angle to the vertical. In this case the impact face of the block must be adjusted by means of an additional support so that it is parallel to the protection structure at the point of impact at the moment of maximum deflection, the supporting chains or wire ropes remaining at the angle defined above.

The suspended height of the block must be adjusted and necessary steps taken so as to prevent the block from turning about the point of impact.

The point of impact is that part of the protection structure likely to hit the ground first in a rearward overturning accident, normally the upper edge. The position of the centre of gravity of the block is one-sixth of the width of the top of the protection structure inwards from a vertical plane parallel to the median plane of the tractor touching the outside extremity of the top of the protection structure.

If the structure is curved or protruding at this point, wedges enabling the impact to be applied thereon must be added, without thereby reinforcing the structure.

- 1.1.2. The tractor must be lashed to the ground by means of four wire ropes, one at each end of both axles, arranged as indicated in Figure 5 of Annex V. The spacing between the front and rear lashing points must be such that the wire ropes make an angle of less than 30° with the ground. The rear lashings must in addition be so arranged that the point of convergence of the two wire ropes is located in the vertical plane in which the centre of gravity of the block travels.

The wire ropes must be tensioned so that the tyres undergo the deflections given in section 6.2 of Annex III A.

With the wire ropes tensioned, the wedging beam must be placed in front of and tight against the rear wheels and then fixed to the ground.

- 1.1.3. If the tractor is of the articulated type, the point of articulation must in addition be supported by a wooden block at least 100 mm square and firmly lashed to the ground.

- 1.1.4. The pendulum block must be pulled back so that the height of its centre of gravity above that at the point of impact is given by one of the following two formulae, to be chosen according to the reference mass of the assembly subjected to the tests:

$$H = 25 + 0,07 m_1 \text{ for assemblies with a reference mass of less than 2 000 kilograms,}$$

$$H = 125 + 0,02 m_1 \text{ for assemblies with a reference mass of more than 2 000 kilograms.}$$

The block is then released and strikes the protection structure.

1.2. Impact at the front

- 1.2.1. The tractor must be so placed in relation to the pendulum block that the block will strike the protection structure when the impact face of the block and the supporting chains or wire ropes are at an angle with the vertical plane equal to $m_1/100$ with a 20° maximum, unless, during deflection, the protection structure at the point of contact forms a greater angle to the vertical. In this case the

impact face of the block must be adjusted by means of an additional support so that it is parallel to the protection structure at the point of impact at the moment of maximum deflection, the supporting chains or wire ropes remaining at the angle defined above.

The suspended height of the pendulum block must be adjusted and the necessary steps taken so as to prevent the block from turning about the point of impact.

The point of impact is that part of the protection structure likely to hit the ground first if the tractor overturned sideways while travelling forward, normally the upper edge. The position of the centre of gravity of the weight is one-sixth of the width of the top of the protection structure inwards from a vertical plane parallel to the median plane of the tractor touching the outside extremity of the top of the protection structure.

If the structure is curved or protruding at this point, wedges enabling the impact to be applied thereon must be added, without thereby reinforcing the structure.

- 1.2.2. The tractor must be lashed to the ground by means of four wire ropes, one at each end of both axles, arranged as indicated in Figure 6 of Annex V. The spacing between the front and rear lashing points must be such that the wire ropes make an angle of less than 30° with the ground. The rear lashings must in addition be so arranged that the point of convergence of the two wire ropes is located in the vertical plane in which the centre of gravity of the pendulum blocks travels. The wire ropes must be tensioned so that the tyres undergo the deflections given in section 6.2 of Annex III A. With the wire ropes tensioned, the wedging beam must be placed behind and tight against the rear wheels and then fixed to the ground.

- 1.2.3. If the tractor is of the articulated type, the point of articulation must in addition be supported by a wooden block at least 100 mm square and firmly lashed to the ground.

- 1.2.4. The pendulum block must be pulled back so that the height of its centre of gravity above that at the point of impact is given by one of the following two formulae, to be chosen according to the reference mass of the assembly subjected to the tests:

$$H = 25 + 0,07 m_r \text{ for assemblies with a reference mass of less than 2 000 kilograms,}$$

$$H = 125 + 0,02 m_r \text{ for assemblies with a reference mass of more than 2 000 kilograms.}$$

The pendulum block is then released and strikes the protection structure.

1.3. Impact from the side

- 1.3.1. The tractor must be so placed in relation to the pendulum block that the block will strike the protection structure when the impact face of the weight and the supporting chains or wire ropes are vertical unless, during deflection, the protection structure at the point of contact forms an angle of less than 20° to the vertical.

In this case the impact face of the block must be adjusted by means of an additional support so that it is parallel to the protection structure at the point of impact at the moment of maximum deflection, the supporting chains or wire ropes remaining vertical on impact.

The suspended height of the pendulum block must be adjusted and necessary steps taken so as to prevent the block from turning about the point of impact.

The point of impact must be that part of the protection structure likely to hit the ground first in a sideways overturning accident.

- 1.3.2. The tractor wheels on the side which is to receive the impact must be lashed to the ground by means of wire ropes passing over the corresponding ends of the front and rear axles. The wire ropes must be tensioned to produce the tyre deflection values given in section 6.2 of Annex III A.

With the wire ropes tensioned, the wedging beam must be placed on the ground, pushed tight against the tyres on the side opposite that which is to receive the impact and then fixed to the ground. It may be necessary to use two beams or wedges if the outer sides of the front and rear tyres are not in the same vertical plane.

The prop must then be placed as indicated in Figure 7 of Annex V, against the rim of the most heavily loaded wheel opposite to the point of impact, pushed firmly against the rim and then fixed at its base.

The length of the prop must be such that it makes an angle of $30 \pm 3^\circ$ with the ground when in position against the rim. In addition, its length must, if possible, be between 20 and 25 times greater than its thickness and its thickness between two and three times less than its width. The props must be shaped at both ends as shown in the details on Figure 7 of Annex V.

- 1.3.3. If the tractor is of the articulated type, the point of articulation must in addition be supported by a wooden block at least 100 mm square and laterally supported by a device similar to the prop pushed against the rear wheel. The point of articulation must then be lashed firmly to the ground.

- 1.3.4. The weight must be pulled back so that the height of its centre of gravity above that at the point of impact is given by one of the following two formulae, to be chosen according to the reference mass of the assembly subjected to the tests:

$$H = (25 + 0,20 m_t) \cdot \frac{B_h + B}{2B} \text{ for assemblies with a reference mass of less than 2 000 kilograms,}$$

$$H = (125 + 0,15 m_t) \cdot \frac{B_h + B}{2B} \text{ for assemblies with a reference mass of more than 2 000 kilograms,}$$

where B_h is the maximum outer width of the protection structure, and B is the minimum overall width of the tractor.

1.4. Crushing at the rear

The beam must be positioned over the rear uppermost structural member(s) and the resultant of crushing forces must be located in the tractor's median plane.

A force $F_v = 20 m_t$ must be applied.

Where the rear part of the protection structure roof will not sustain the full crushing force, the force must be applied until the roof is deflected to coincide with the place joining the upper part of the protection structure with that part of the rear of the tractor capable of supporting the vehicle's mass when overturned. The force must then be removed, and the tractor or loading force repositioned so that the beam is over that point of the protection structure which would then support the tractor when completely overturned.

The force F_v is then applied. The force is applied for a minimum of five seconds following the cessation of any visually detectable deflection.

1.5. Crushing at the front

The beam must be positioned across the front uppermost structural member(s) and the resultant of crushing forces must be located in the tractor's median plane.

A force $F_v = 20 m_t$ must be applied.

Where the front part of the protection structure roof will not sustain the full crushing force, the force must be applied until the roof is deflected to coincide with the plane joining the upper part of the protection structure with that part of the front of the tractor capable of supporting the vehicle's mass when overturned. The force must then be removed, and the tractor or loading force repositioned so that the beam is over that point of the protection structure which would then support the tractor when completely overturned.

The force F_v is then applied. The force is applied for a minimum of five seconds following the cessation of any visually detectable deflection.

1.6. Additional test

If cracks or tears which cannot be considered negligible appear during a crushing test, a second similar crushing test, but with a force of $1,2 F_v$, must be applied immediately after the crushing test, which caused the cracks or tears to appear.

2. ZONE OF CLEARANCE

2.1. The zone of clearance is shown in Annex V, Figures 2a, 2b, 2c, 2d and 2e.

The zone of clearance is defined on the basis of:

- 2.1.1. A vertical reference plane, generally longitudinal to the tractor and passing through the seat reference point and the centre of the steering wheel; this plane must be able to move horizontally with the seat and steering wheel during impacts but to remain perpendicular to the floor of the tractor or of the protection structure if this is resiliently mounted.
- 2.1.2. A reference line contained in the reference plane, which passes through the seat reference point and the first point on the steering wheel rim that it intersects when brought to the horizontal.
- 2.2. The zone of clearance is bounded by the following planes, the tractor being on a horizontal surface and, where the steering wheel is adjustable, its position adjusted for the middle position for driving.
 - 2.2.1. Two vertical planes 250 mm on either side of the reference plane, these vertical planes extending 300 mm upwards from the horizontal plane passing through the seat reference point and longitudinally at least 550 mm in front of the vertical plane perpendicular to the reference plane passing 350 mm in front of the seat reference point.
 - 2.2.2. Two vertical planes 200 mm on either side of the reference plane, these vertical planes extending 300 mm upwards from the horizontal plane passing through the seat reference point and longitudinally from the surface defined in 2.2.11 to the vertical plane perpendicular to the reference plane passing 350 mm in front of the seat reference point.
 - 2.2.3. An oblique plane perpendicular to the reference plane, parallel with and 400 mm above the reference line, extending backwards to the point where it intersects the vertical plane which is perpendicular to the reference plane and which passes through the seat reference point.
 - 2.2.4. An oblique plane, perpendicular to the reference plane and resting on the top of the seat backrest, which meets the previous plane at its rearmost edge.
 - 2.2.5. A vertical plane perpendicular to the reference plane, passing at least 40 mm forward of the steering wheel and at least 900 mm forward of the seat reference point.
 - 2.2.6. A curvilinear surface with its axis perpendicular to the reference plane, having a radius of 150 mm and meeting the planes defined in 2.2.3 and 2.2.5 at a tangent.
 - 2.2.7. Two parallel oblique planes passing through the upper edges of the planes defined in 2.2.1, with the oblique plane on the side where the impact is applied no closer than 100 mm to the reference plane above the zone of clearance,
 - 2.2.8. A horizontal plane passing through the seat reference point.
 - 2.2.9. Two portions of the vertical plane perpendicular to the reference plane passing 350 mm forward of the seat reference point, both these part planes joining respectively the rearmost limits of the planes defined in 2.2.1 to the foremost limits of the planes defined in 2.2.2.
 - 2.2.10. Two portions of the horizontal plane passing 300 mm above the seat reference point, both these part planes joining respectively the uppermost limits of the vertical planes defined in 2.2.2 to the lowermost limits of the oblique planes defined in 2.2.7.
 - 2.2.11. A curvilinear surface whose generating line is perpendicular to the reference plane and rests on the back of the seat backrest.

2.3. **Seat location and seat reference point**

2.3.1. *Seat reference point*

2.3.1.1. The reference point must be established by means of the apparatus illustrated in Figures 3a and 3b of Annex V. The apparatus consists of a seat pan board and backrest boards. The lower backrest board is jointed in the region of the ischium humps (A) and loin (B), the joint (B) being adjustable in height.

2.3.1.2. The reference point is defined as the point in the median longitudinal plane of the seat where the tangential plane of the lower backrest and a horizontal plane intersect. This horizontal plane cuts the lower surface of the seat pan board 150 mm in front of the abovementioned tangent.

2.3.1.3. The apparatus is positioned on the seat. It is then loaded with a force of 550 N at a point 50 mm in front of joint (A), and the two parts of the backrest board lightly pressed tangentially against the backrest.

2.3.1.4. If it is not possible to determine definite tangents to each area of the backrest (above and below the lumbar region) the following steps must be taken:

2.3.1.4.1. Where no definite tangent to the lower area is possible, the lower part of the backrest board is pressed against the backrest vertically.

2.3.1.4.2. Where no definite tangent to the upper area is possible, the joint (B) is fixed at a height of 230 mm above the lower surface of the seat pan board, the backrest board being perpendicular to the seat pan board. Then the two parts of the backrest board are lightly pressed against the backrest tangentially

2.3.2. *Seat position and adjustment for determining the location of the seat reference point*

2.3.2.1. Where the seat position is adjustable, the seat must be adjusted to its rear uppermost position.

2.3.2.2. Where the inclination of the backrest and seat pan is adjustable, these must be adjusted so that the reference point is in its rear uppermost position.

2.3.2.3. Where the seat is equipped with suspension, the latter must be blocked at mid-travel, unless this is contrary to the instructions clearly laid down by the seat manufacturer. If such instructions exist, they must be complied with.

3. **MEASUREMENTS TO BE MADE**

3.1. **Fractures and cracks**

After each test all structural members, joints and fastening systems shall be visually examined for fractures or cracks, any small cracks in unimportant parts being ignored.

Any tears caused by the edges of the pendulum weight are to be ignored.

3.2. **Zone of clearance**

3.2.1. During each test the protection structure must be examined to see whether any part of the protection structure has entered a zone of clearance round the driving seat as defined in section 2 of this Annex.

3.2.2. In addition, the protection structure must be examined to determine whether any part of the zone of clearance is outside the protection of the structure. For this purpose it is considered to be outside the protection of the roll-over protection structure if any part of it would have come in contact with the ground plane if the tractor had overturned in the direction from which the impact came. For this purpose the front and rear tyres and track setting are assumed to be the smallest specified by the manufacturer. Moreover, if the tractor is fitted with a rigid section, a housing or other hard fixture

placed behind the driver's seat, this fixture shall be regarded as a protection point, in the event of sideways or rear overturning. However, the height of this rear structure over the seat reference point must be less than 500 mm (see Annex V, figure 2 f).

In addition, it must be sufficiently rigid and firmly attached to the rear of the tractor. This structure mounted on the tractor should withstand, without breaking, a load which will be defined six months before implementation of the Directive, together with any detailed instructions for the testing to be carried out, under the procedure for adaptation to technical progress; this load will be applied horizontally at the point likely to hit the ground first if the tractor up-ends.

3.3. Elastic deflection

The elastic deflection is measured 900 mm above the reference point, in the vertical plane passing through the point of impact. For this measurement, apparatus similar to that illustrated in Figure 9, Annex V, must be used.

3.4. Permanent deflection

After the final crushing test the permanent deflection of the protection structure is recorded. For this purpose, before the start of the test, the position of the main roll-over protection structure members in relation to the seat reference point must be recorded.

B. Static tests

1. LOADING AND CRUSHING TESTS

1.1. Loading at the rear

1.1.1. The load is applied horizontally, in a vertical plane parallel to the tractor's median plane.

The load application point is that part of the roll-over protection structure likely to hit the ground first in a rearward overturning accident, normally the upper edge. The vertical plane in which the load is applied is located at a distance of one-third of the external width of the upper part of the structure from the median plane.

If the structure is curved or protruding at this point, wedges enabling the load to be applied thereon must be added, without thereby reinforcing the structure.

1.1.2. The assembly is lashed to the ground as described in section 3 of Annex III B.

1.1.3. The energy absorbed by the protection structure during the test must be at least

$$E_{il} = 500 + 0,5 m_t.$$

1.2. Loading at the front

1.2.1. The load is applied horizontally, in a vertical plane parallel to the tractor's median plane and located at a distance of one-third of the external width of the upper part of the structure therefrom.

The load application point is that part of the roll-over protection structure likely to hit the ground first if the tractor overturned sideways while travelling forward, normally the upper edge.

If the structure is curved or protruding at this point, wedges enabling the load to be applied thereon must be added, without thereby reinforcing the structure.

1.2.2. The assembly is lashed to the ground as described in section 3 of Annex III B.

- 1.2.3. The energy absorbed by the protection structure during the test must be at least

$$E_{ij} = 500 + 0,5 m_t.$$

1.3. **Loading from the side**

- 1.3.1. The side loading is applied horizontally, in a vertical plane perpendicular to the tractor's median plane.

The load application point is that part of the roll-over protection structure likely to hit the ground first in a sideways overturning accident, normally the upper edge.

- 1.3.2. The assembly must be lashed to the ground as described in section 3 of Annex III B.

- 1.3.3. The energy absorbed by the protection structure during the test must be at least

$$E_{is} = 1,75 m_t \frac{B_b + B}{2B}$$

where B_b is the maximum external width of the protection structure and B is the minimum overall width of the tractor.

1.4. **Crushing at the rear**

All provisions identical to those given in section 1.4 of Annex IV A.

1.5. **Crushing at the front**

All provisions identical to those given in section 1.5 of Annex IV A.

1.6. **Overload test (additional test)**

- 1.6.1. An overload test must be carried out in all cases where the force decreases by more than 3 % during the last 5 % of the deflection reached when the energy required is absorbed by the structure (see Figure 10b).

- 1.6.2. The overload test involves the gradual increase of the horizontal load by increments of 5 % of the initial energy requirement up to a maximum of 20 % of energy added (see Figure 10c).

- 1.6.2.1. The overload test is satisfactory if, after each increase by 5, 10, or 15 % in the energy required, the force decreases by less than 3 % for a 5 % increment and remains more than $0,8 F_{max}$.

- 1.6.2.2. The overload test is satisfactory if, after the structure has absorbed 20 % of the added energy, the force exceeds $0,8 F_{max}$.

- 1.6.2.3. Additional cracks or tears and/or entry into or lack of protection of the zone of clearance due to elastic deflection are permitted during the overload test. However, after the removal of the load, the structure must not enter the zone of clearance, which must be completely protected.

1.7. **Crushing test**

If cracks or tears which cannot be considered as negligible appear during a crushing test, a second, similar crushing, but with a force of $1,2 F_v$, must be applied immediately after the crushing test which caused the cracks or tears to appear.

2. **ZONE OF CLEARANCE**

Identical to the zone of clearance described in section 2 of Annex IV A, except that the word 'impact' is to be replaced by 'load' in the third line of section 2.2.7.

3. MEASUREMENTS TO BE MADE

3.1. Fractures and cracks

After each test all structural members, joints and attachment systems must be visually examined for fractures or cracks, any small cracks in unimportant parts being ignored.

3.2. Zone of clearance

3.2.1. During each test the protection structure must be examined to see whether any part of the protection structure has entered a zone of clearance as defined in section 2 above.

3.2.2. In addition, the protection structure must be examined to determine whether any part of the zone of clearance is outside the protection of the structure. For this purpose it is considered to be outside the protection of the roll-over protection structure if any part of it would have come in contact with the ground plane if the tractor had overturned in the direction from which the impact came. For this purpose the front and rear tyres and track setting are assumed to be the smallest specified by the manufacturer. Moreover, if the tractor is fitted with a rigid section, a housing or other hard fixture placed behind the driver's seat, this fixture shall be regarded as a protection point, in the event of sideways or rear overturning. However, the height of this rear structure over the seat reference point must be less than 500 mm (see Annex V, Figure 2f).

In addition, it must be sufficiently rigid and firmly attached to the rear of the tractor. This structure mounted on the tractor should withstand, without breaking, a load which will be defined six months before implementation of the Directive, together with any detailed instructions for the testing to be carried out, under the procedure for adaptation to technical progress; this load will be applied horizontally at the point likely to hit the ground first if the tractor up-ends.

3.3. Elastic deflection (under side loading)

The elastic deflection is measured 900 mm above the seat reference point, in the vertical plane in which the load is applied. For this measurement, any apparatus similar to that illustrated in Annex V, Figure 9 may be used.

3.4. Permanent deflections

After the final crushing test the permanent deflection of the protection structure is recorded. For this purpose, before the start of the test, the position of the main roll-over protection structure members in relation to the seat reference point must be recorded.

ANNEX V

FIGURES

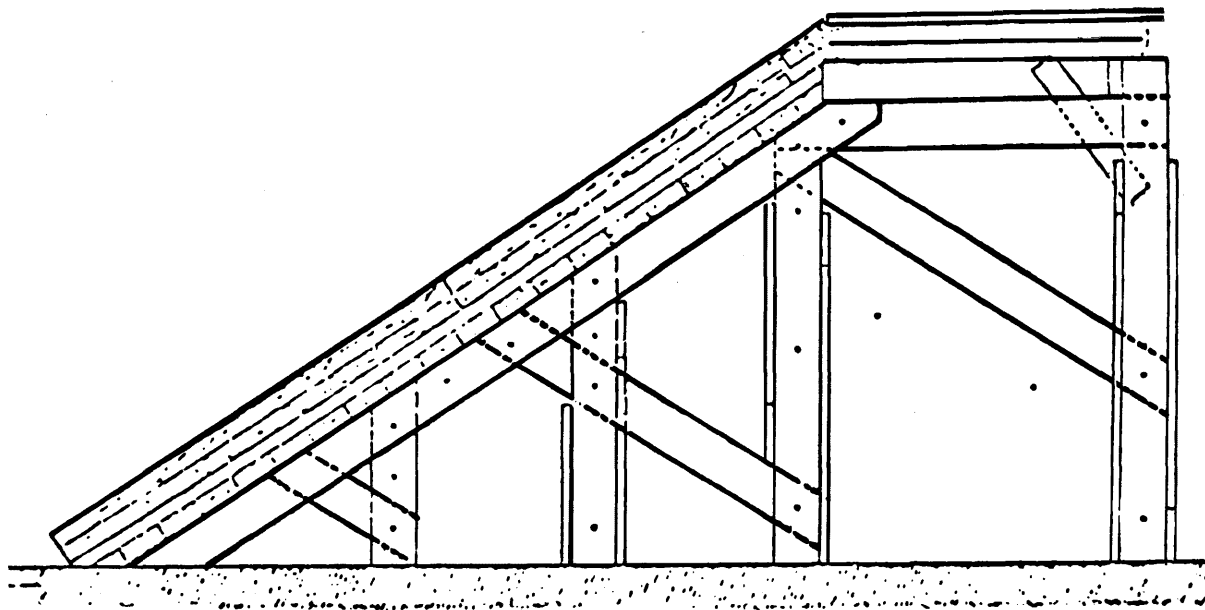

Figure 1

Rig for testing anti-roll properties on 1 in 1,5 gradient

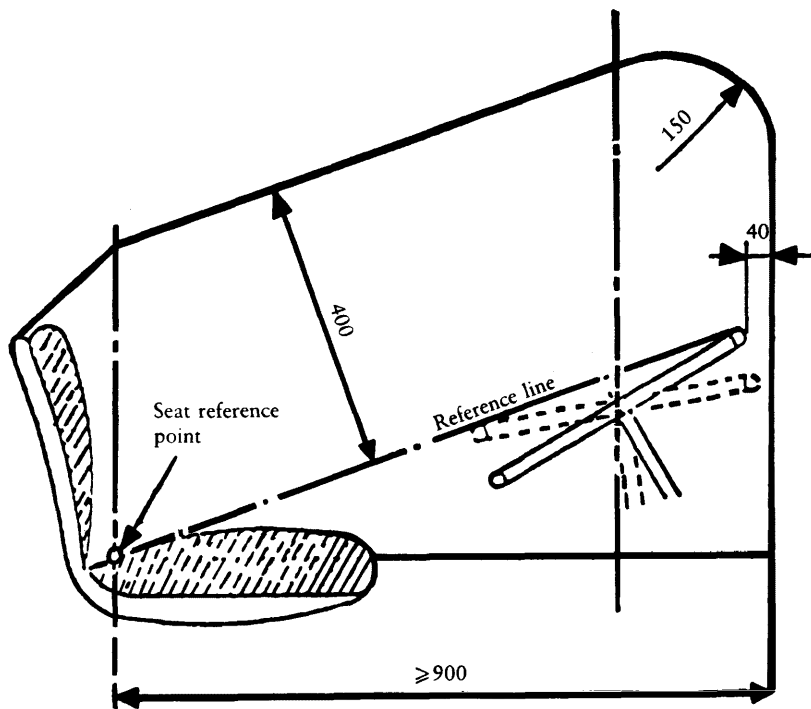

Figure 2a

Zone of clearance — Cross-section through the reference plane

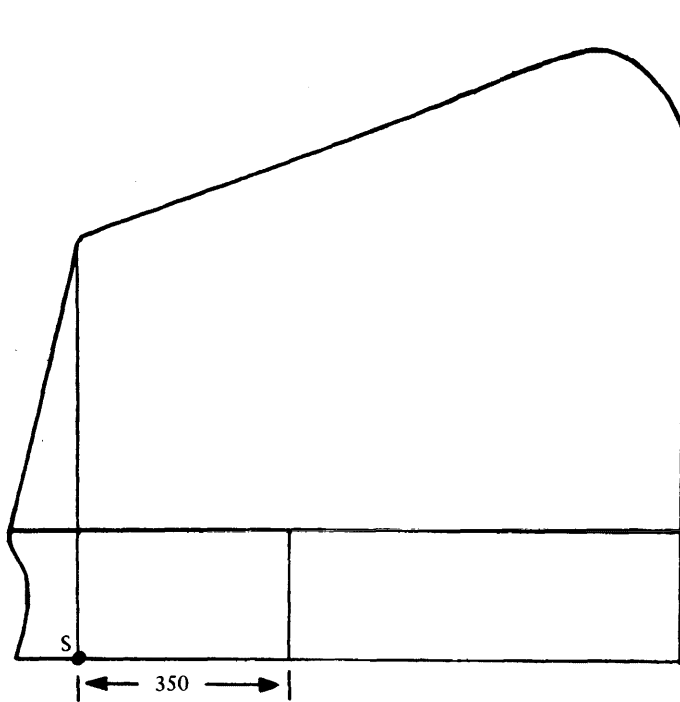

Figure 2b
Zone of clearance — Side view

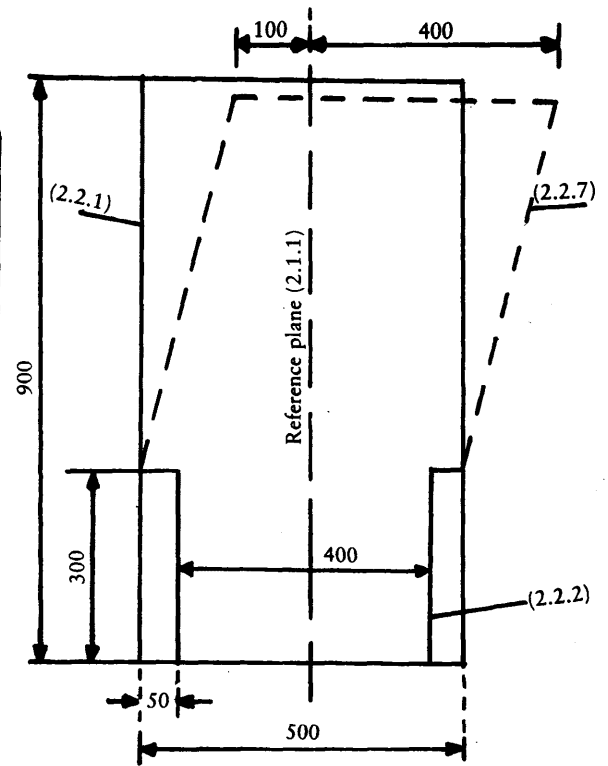

Figure 2c
Zone of clearance — Rear view

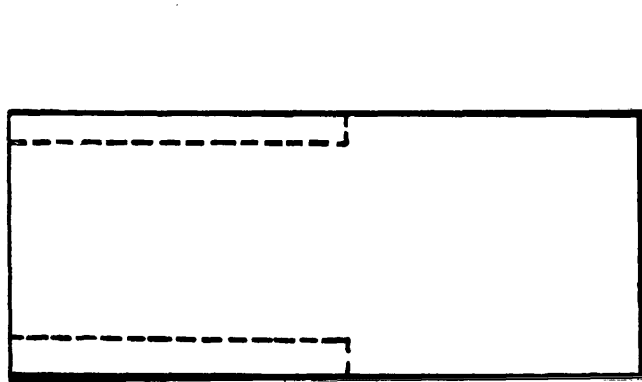

Figure 2d
Zone of clearance — seen from above

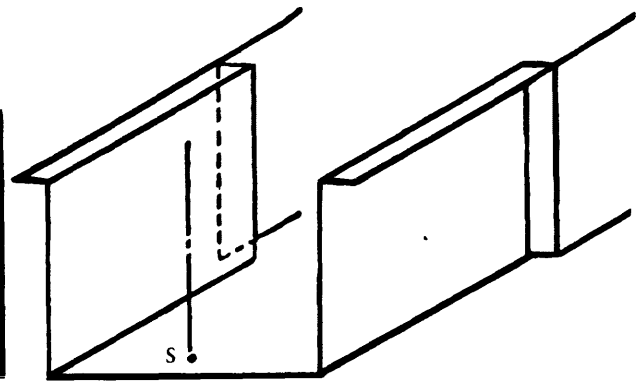

Figure 2e
Lower part of the zone of clearance 3/4 rear view

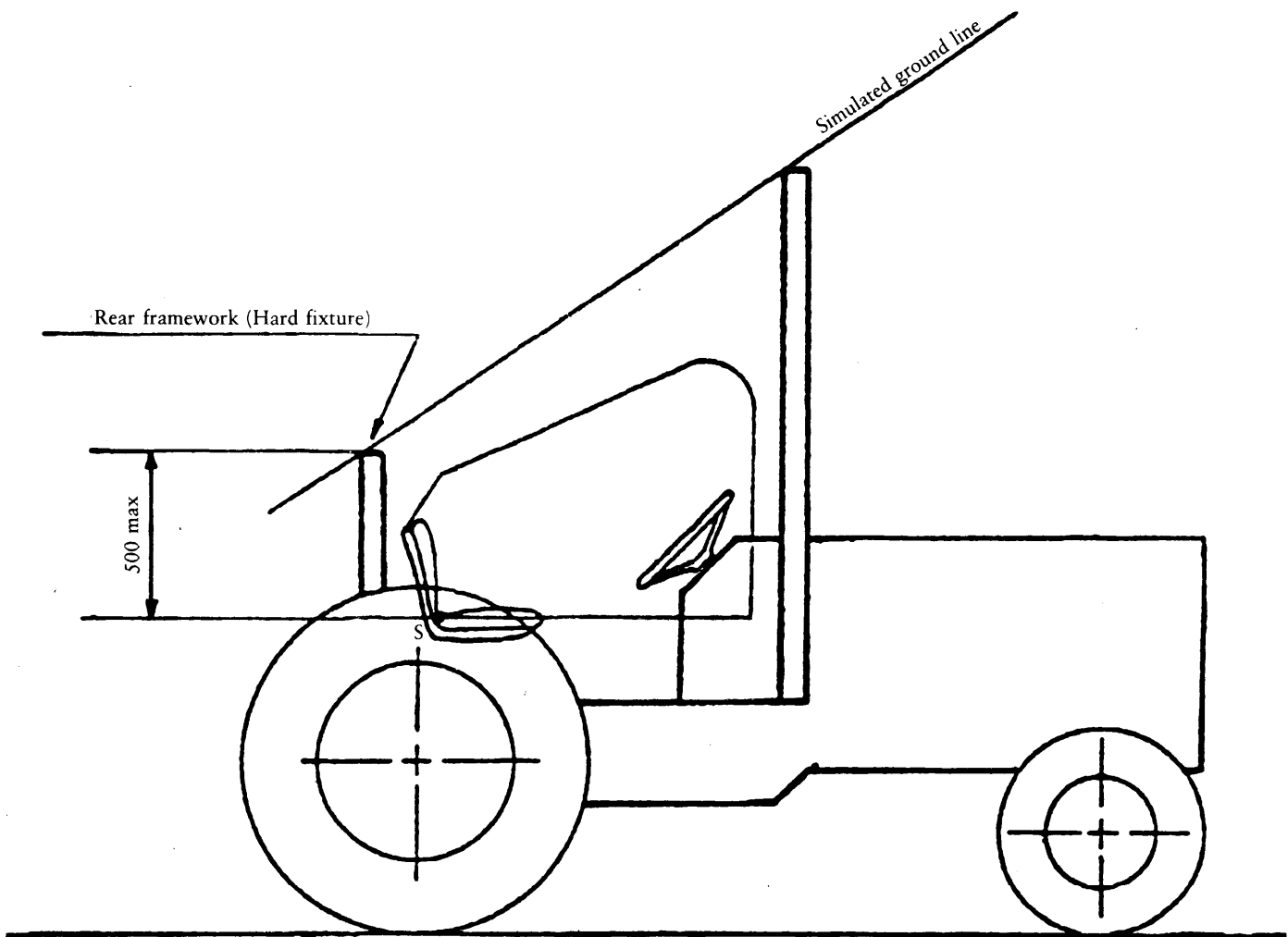

Figure 2f

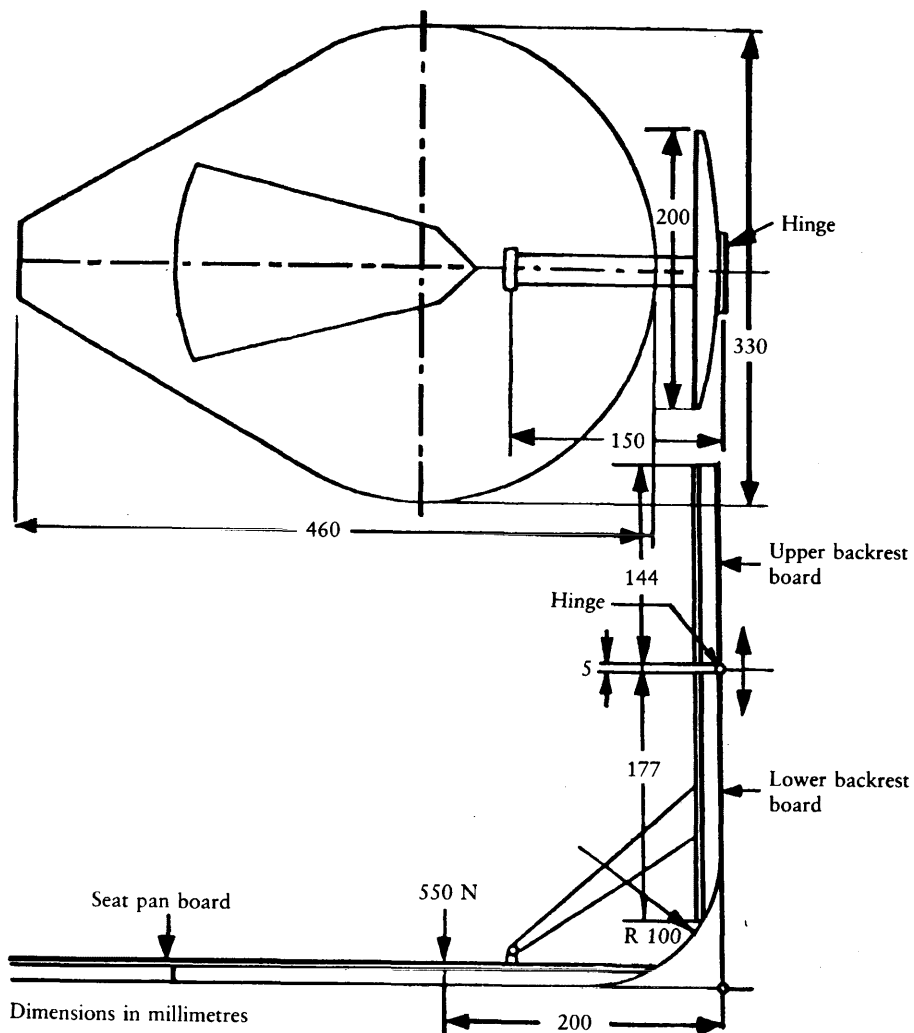

Figure 3a

Apparatus for determination of seat reference point

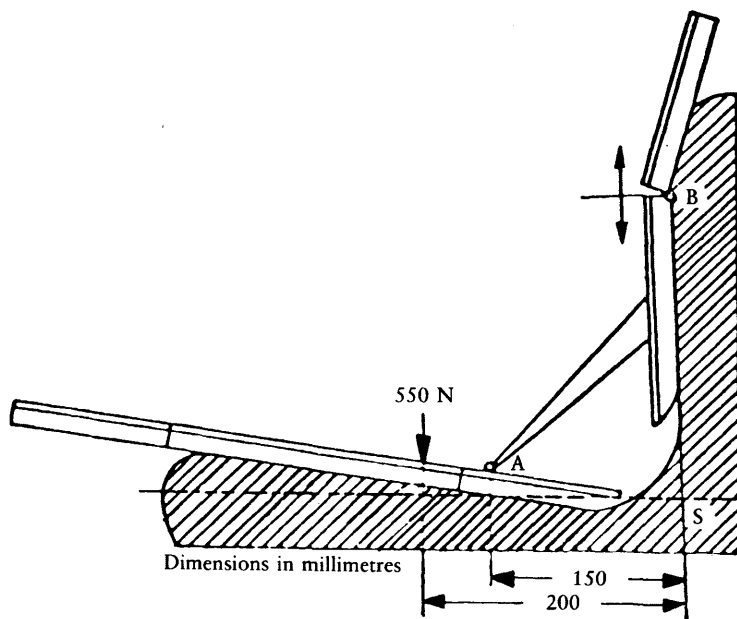

Figure 3b

Method of determining seat reference point

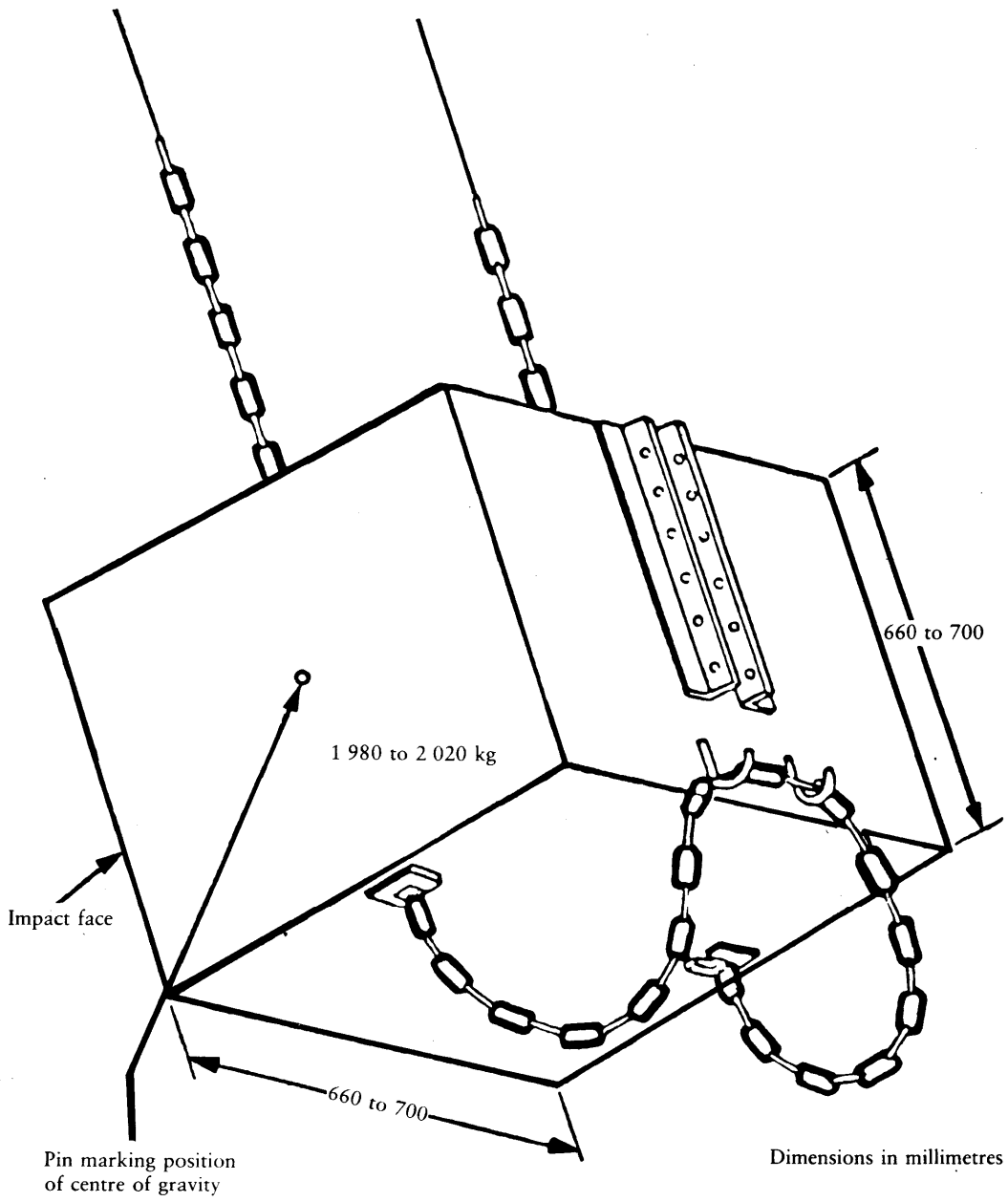

Figure 4

Pendulum block and its suspending chains or wire ropes

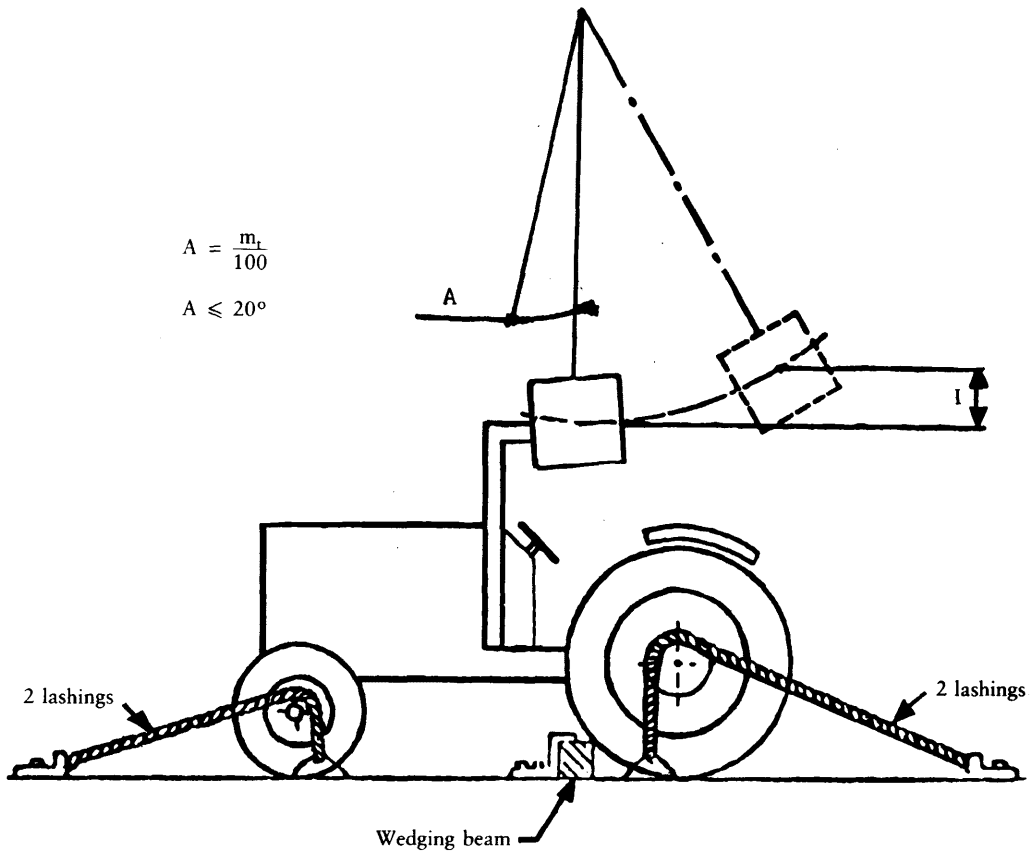

Figure 5

Example of tractor lashing — Rear impact

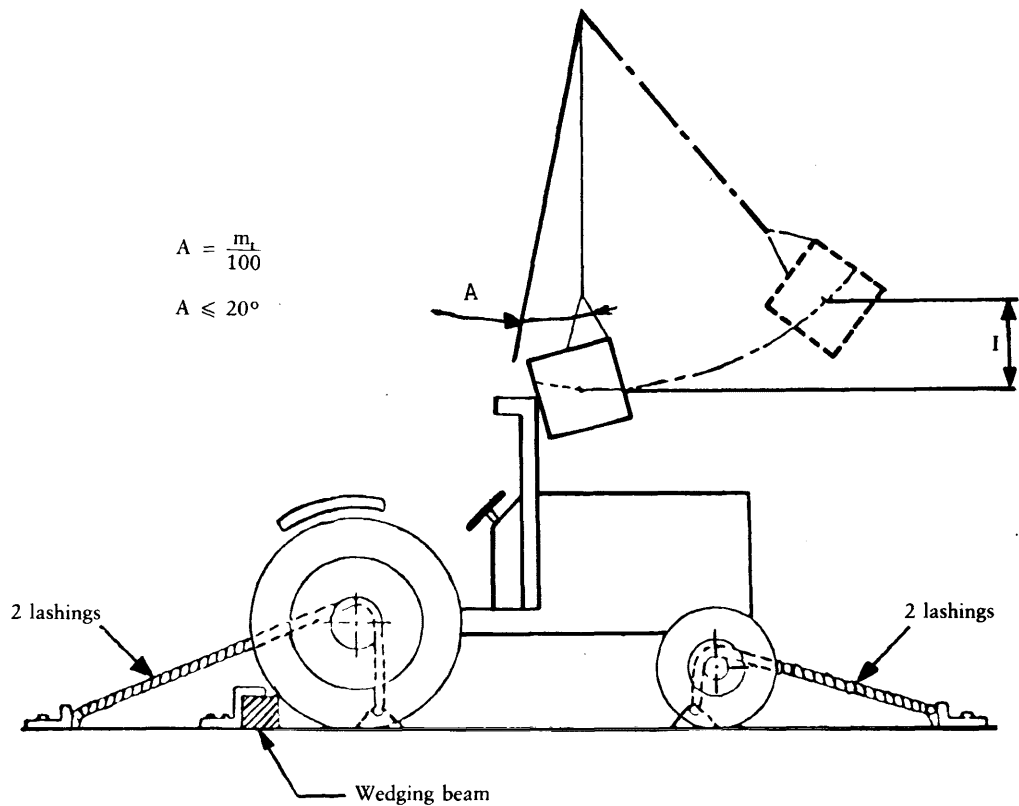

Figure 6

Example of tractor lashing — Front impact

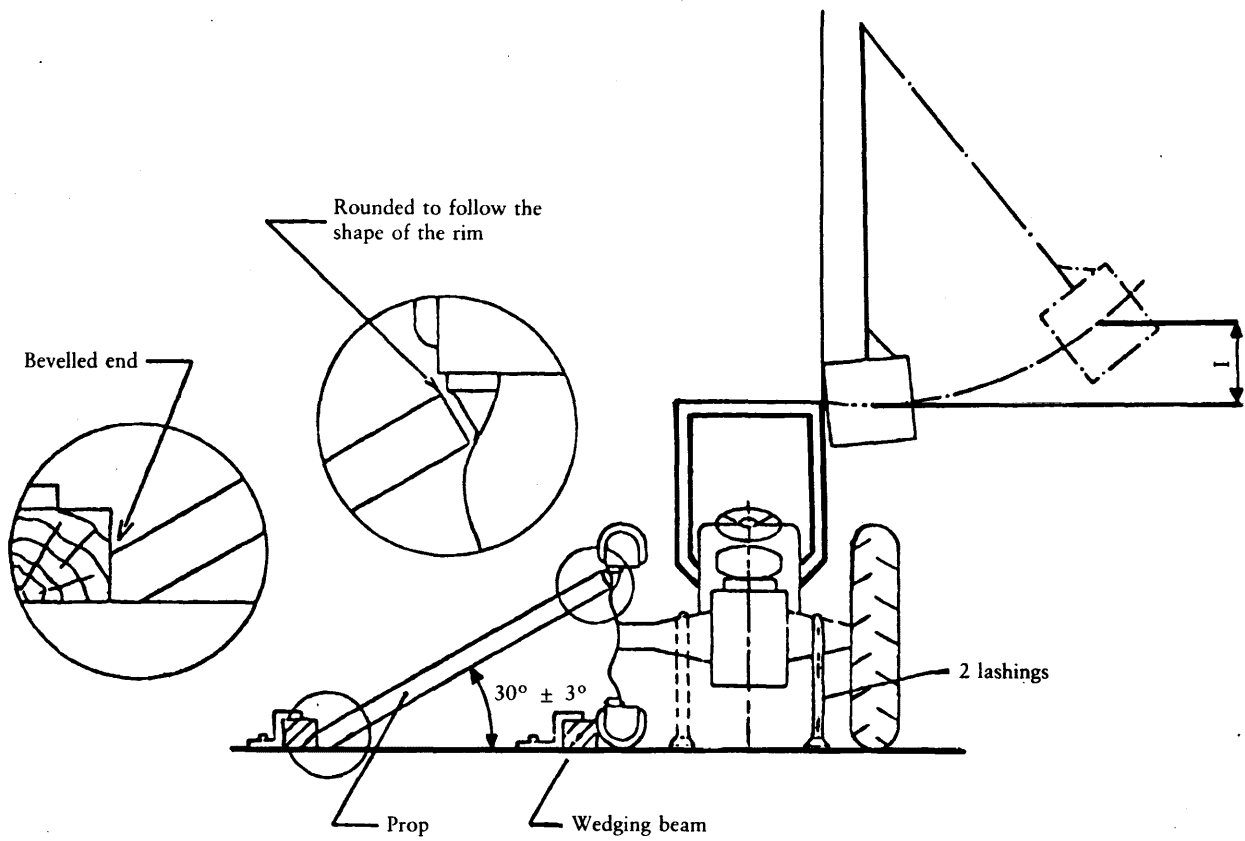

Figure 7

Example of tractor anchorage — Side impact

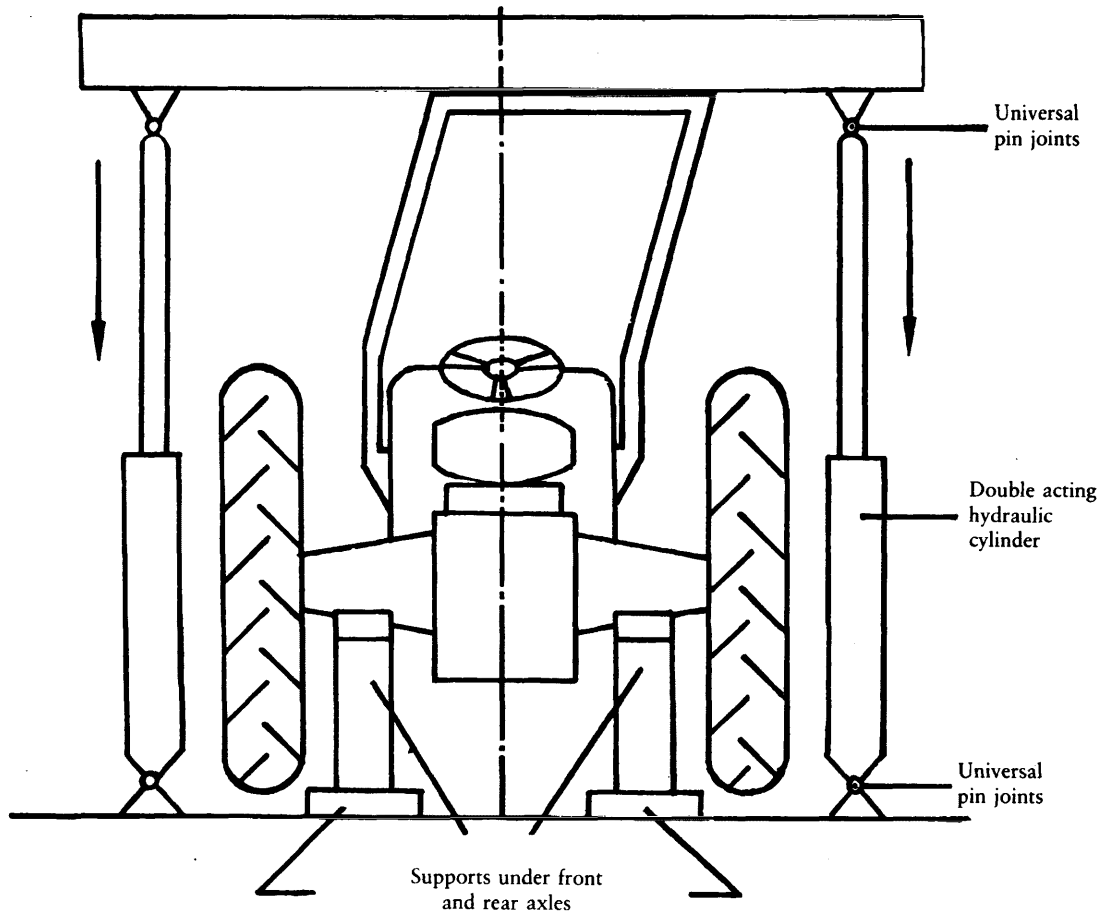
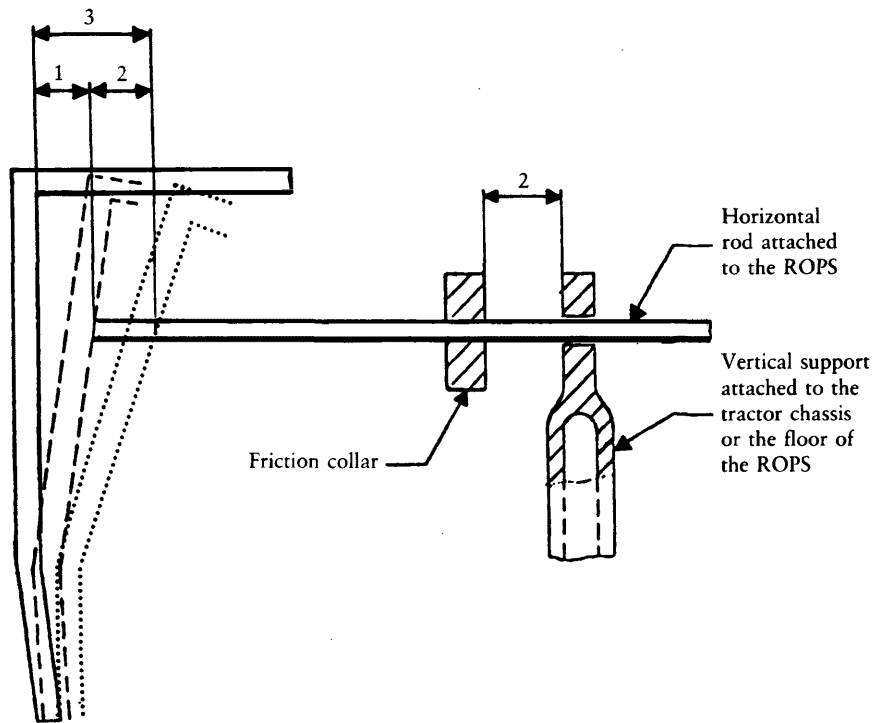

Figure 8
Crushing rig

Note: The configuration of the roll-over protection structure shown is solely for the purpose of illustration and for dimensional reference. It does not purport to denote design requirements.



- 1 — Permanent deflection
- 2 — Elastic deflection
- 3 — Total deflection
(permanent + elastic deflection)

Figure 9

Example of apparatus for measuring elastic deflection

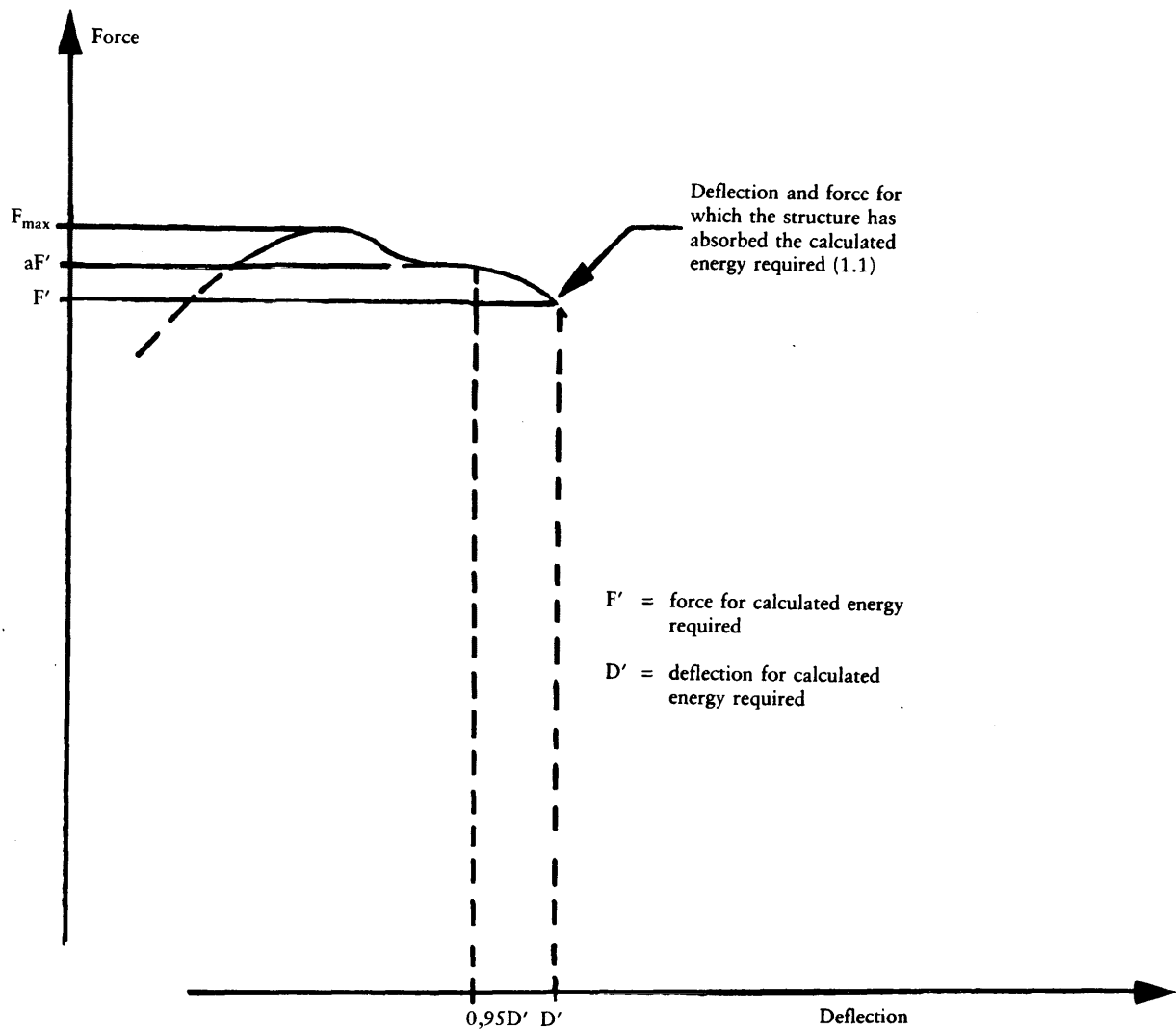

1. Reference aF' corresponding to $0,95 D'$.
- 1.1. Overload test not necessary since $aF' < 1,03 F'$.

Figure 10a

Force/Deflection curve

Overload test not necessary

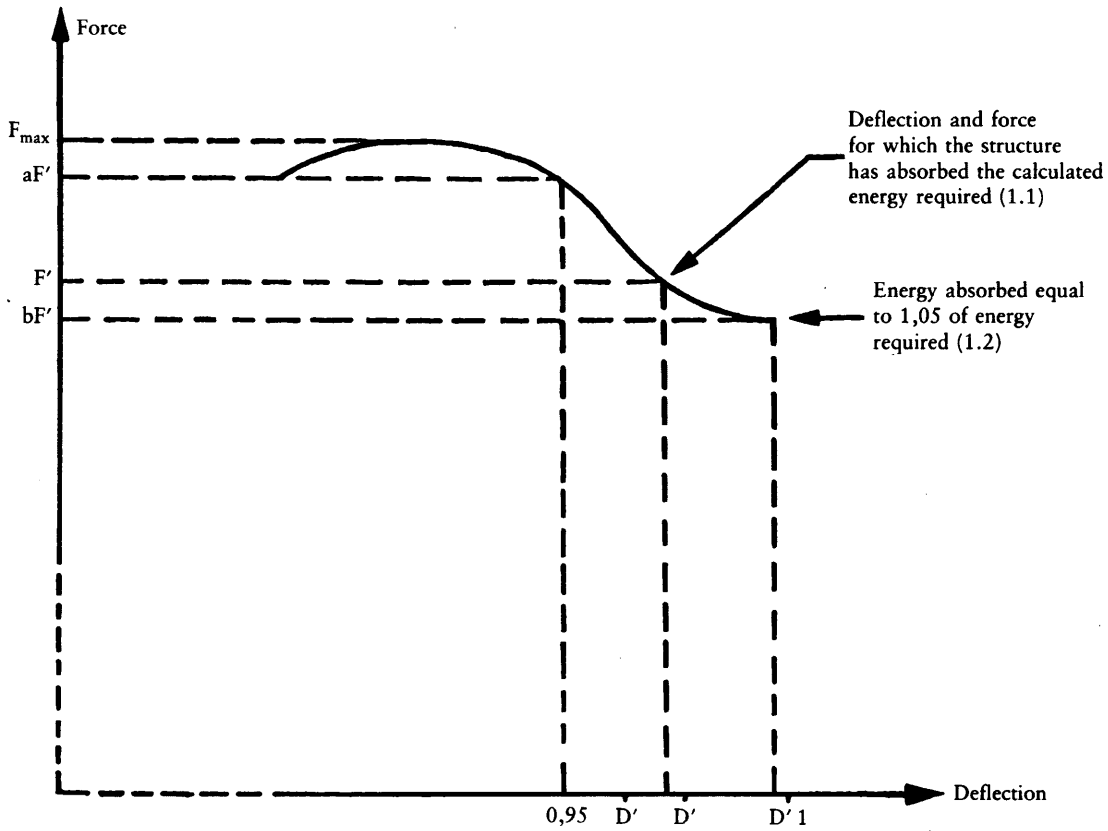

1. Reference aF' corresponding to $0,95 D'$.
- 1.1. Overload test necessary since $aF' > 1,03 F'$.
- 1.2. Overload test satisfactory since $bF' > 0,97 F'$ and $bF' > 0,8 F_{max}$.

Figure 10b

Force/Deflection curve
 Overload test necessary

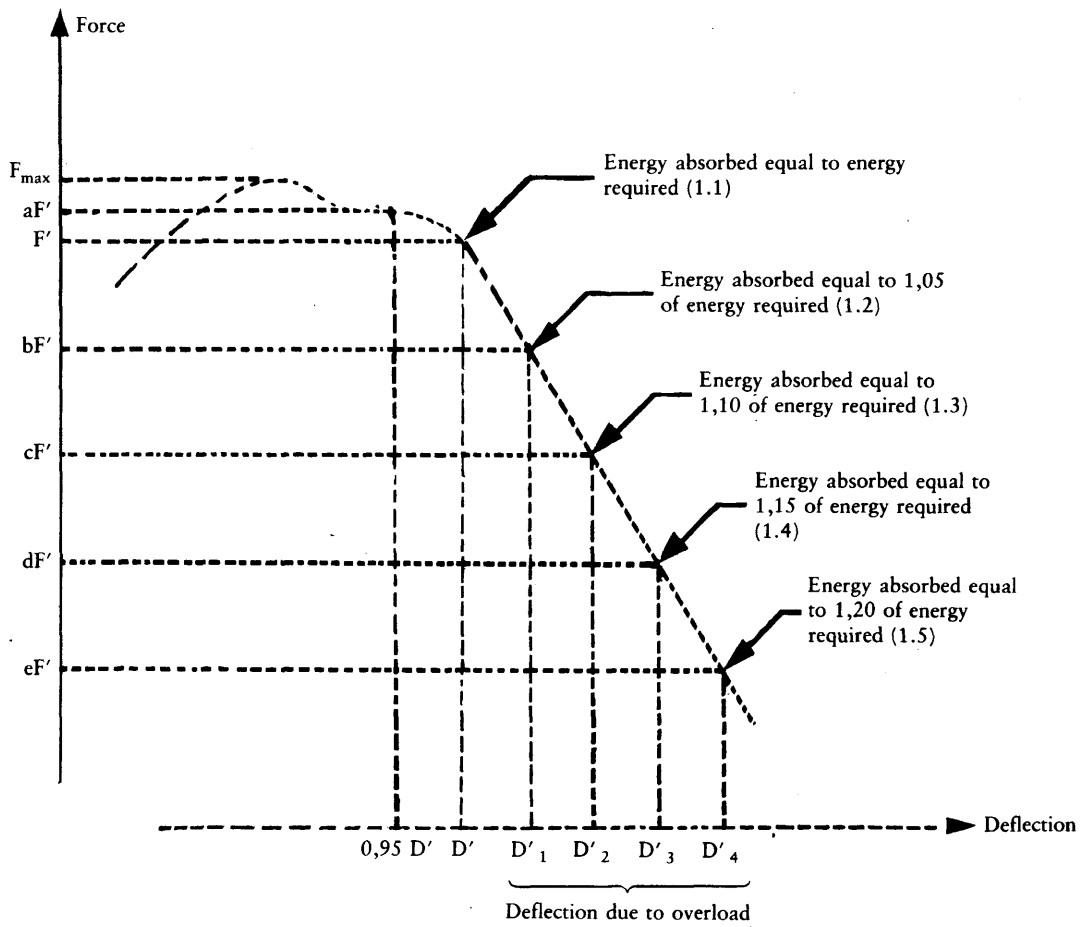

1. Reference aF' corresponding to $0,95 D'$.
- 1.1. Overload test necessary since $aF' > 1,03 F'$.
- 1.2. Since $bF' < 0,97 F'$, overload test to be continued.
- 1.3. Since $cF' < 0,97 bF'$, overload test to be continued.
- 1.4. Since $dF' < 0,97 cF'$, overload test to be continued.
- 1.5. Overload test satisfactory since $eF' > 0,8 F_{max}$.

Note: If at any moment F falls below $0,8 F_{max}$ the structure will be refused.

Figure 10 c
 Force/Deflection curve
 Overload test to be continued

ANNEX VI

MODEL

REPORT RELATING TO THE EEC COMPONENT TYPE-APPROVAL TEST OF A PROTECTION STRUCTURE (FRONT-MOUNTED BAR) WITH REGARD TO ITS STRENGTH AS WELL AS TO THE STRENGTH OF ITS ATTACHMENT TO THE TRACTOR

Protection structure	
Make	
Type	
Tractor make	
Tractor type	
Test method	I/II ⁽¹⁾

Identification of test station

EEC component type-approval No:

1. Trade mark or name of protection structure:

2. Name and address of manufacturer of tractor or protection structure:

3. If applicable, name and address of tractor or protection structure manufacturer's authorized representative:

4. Specifications of tractor on which the tests are carried out

4.1. Trade mark or name:

4.2. Type:

4.3. Serial number:

4.4. Wheelbase/moment of inertia ⁽¹⁾ mm/kgm² ⁽¹⁾

4.5. Tyre sizes: front: rear:

5. Extension of EEC component type-approval to other tractor types

5.1. Trade mark or name:

5.2. Type:

5.3. Mass of unballasted tractor, with roll-over protection structure fitted, without driver: kg

⁽¹⁾ Delete where inapplicable.

- 5.4. Tyre sizes: front
rear

- 6. Specifications of protection structure
 - 6.1. General arrangement drawing of both the protection structure and its attachment to the tractor
 - 6.2. Photographs showing mounting details
 - 6.3. Brief description of roll-over protection structure including type of construction, details of mounting on the tractor, details of cladding, means of access and escape, details of interior padding and features to prevent continuous rolling
 - 6.4. Dimensions
 - 6.4.1. Height of roof members above the loaded tractor seat/above the seat reference point ⁽¹⁾ ... mm
 - 6.4.2. Height of roof members above the tractor platform mm
 - 6.4.3. Minimum distance from the steering wheel rim to the protection structure mm
 - 6.4.4. Overall height of the tractor with the protection structure fitted mm
 - 6.4.5. Overall width of the protection structure: mm
 - 6.5. Details and quality of materials used, standards used:
 - Main frame: (material and dimensions)
 - Mountings: (material and dimensions)
 - Roof: (material and dimensions)
 - Interior padding: (material and dimensions)
 - Assembly and mounting bolts: (grade and dimensions)

- 7. Test results
 - 7.1. Impact/load ⁽¹⁾ and crushing tests

Impact/load tests were made to the left/right-hand ⁽²⁾ rear and to the right/left-hand ⁽²⁾ front and right/left-hand side ⁽²⁾. The reference mass used for calculating impact energies and crushing forces was

The test requirements concerning fractures or cracks, maximum instantaneous deflection and the zone of clearance were/were not ⁽²⁾ satisfactorily fulfilled.
 - 7.2. Deflection measured after the tests

Permanent deflection:

 - rear: left-hand: mm
 - right-hand: mm
 - front: left-hand: mm
 - right-hand: mm

⁽¹⁾ Delete where inapplicable, according to the test method used.

⁽²⁾ Delete where inapplicable.

side sideways:

front: mm

rear: mm

top downwards:

front: mm

rear: mm

Difference between maximum momentary and residual deflection during sideways impact test:

..... mm

8. Report number:

9. Report date:

10. Signature:

ANNEX VII

MARKS

The EEC component type-approval mark consists of:

- a rectangle surrounding the lower-case letter 'e' followed by the distinguishing letter(s) or number of the Member State which has granted the component type-approval:
 - 1 for Germany,
 - 2 for France,
 - 3 for Italy,
 - 4 for the Netherlands,
 - 6 for Belgium,
 - 9 for Spain,
 - 11 for the United Kingdom,
 - 13 for Luxembourg,
 - 18 for Denmark,
 - IRL for Ireland,
 - EL for Greece,
 - P for Portugal,
- the EEC component type-approval number which corresponds to the number of the EEC component type-approval certificate issued with regard to the strength of the type of protection structure and its attachment to the tractor placed under and in the vicinity of the rectangle,
- the letters V or SV, depending on whether a dynamic (V) or static (SV) test was conducted, followed by the number 2, indicating that this is a protection structure within the meaning of the Directive.

EXAMPLE OF AN EEC COMPONENT TYPE-APPROVAL MARK

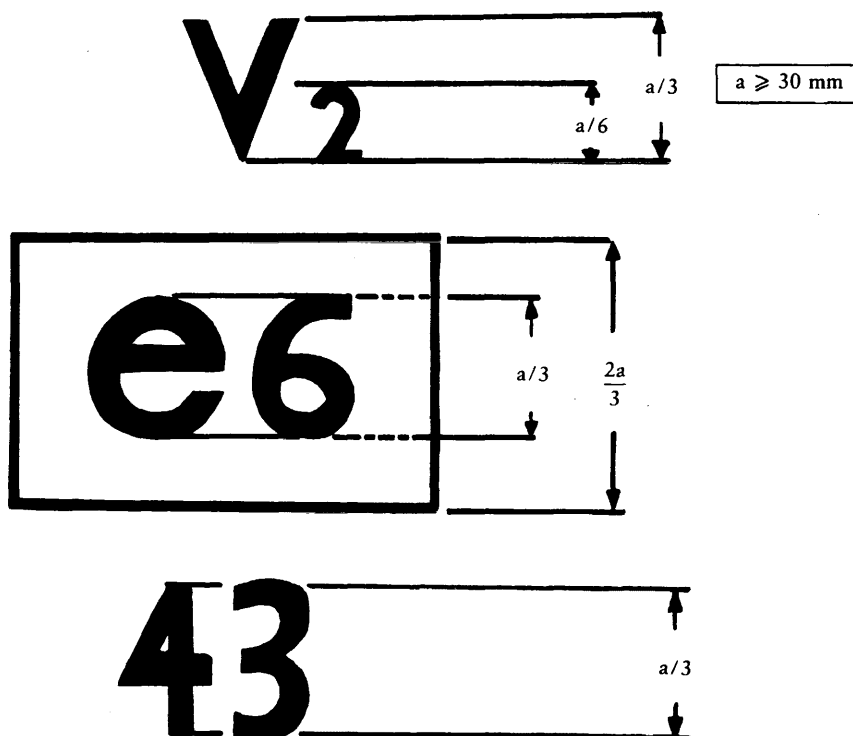

Legend: The protection structure bearing the EEC component type-approval mark shown above is a structure of the bar type subjected to a dynamic test with two front-mounted uprights intended for a narrow-track tractor (V2), for which EEC component type-approval was granted in Belgium (e6) under the number 43.

ANNEX VIII

MODEL EEC COMPONENT TYPE-APPROVAL CERTIFICATE

Name of competent authority

NOTIFICATION CONCERNING THE GRANTING, REFUSAL, WITHDRAWAL OR EXTENSION OF EEC COMPONENT TYPE-APPROVAL WITH REGARD TO THE STRENGTH OF A PROTECTION STRUCTURE (FRONT-MOUNTED BAR) AND TO THE STRENGTH OF ITS ATTACHMENT TO THE TRACTOR

- EEC component type-approval No: extension ⁽¹⁾
1. Trade name or mark and type of protection structure:
 2. Name and address of manufacturer of protection structure:
 3. If applicable, name and address of authorized representative of manufacturer of protection structure:
 4. Trade mark or name and type of tractor for which protection structure is intended:
 5. Extension of EEC component type-approval for the following tractor type(s):
 - 5.1. The mass of the unballasted tractor, as defined in 1.4 of Annex III, exceeds/does not exceed ⁽²⁾ the reference mass used for the test by more than 5 %
 - 5.2. The method of attachment and points of attachment are/not ⁽²⁾ identical
 - 5.3. All the components likely to serve as supports for the protection structure are/are not ⁽²⁾ identical
 6. Date of submission for EEC component type-approval:
 7. Test station:
 8. Date and number of the report of the test station:
 9. Date of granting/refusal/withdrawal of EEC component type-approval ⁽²⁾:
 10. Date of granting/refusal/withdrawal of the extension of EEC component type-approval ⁽²⁾:
 11. Place:
 12. Date:
 13. The following documents, bearing the component type-approval number shown above, are annexed to this certificate (e.g. report of the test station):
 14. Remarks, if any:
 15. Signature:

⁽¹⁾ If applicable, state whether this is the first, second, etc. extension of the original EEC component type-approval.

⁽²⁾ Delete where inapplicable.

ANNEX IX

CONDITIONS FOR EEC TYPE-APPROVAL

1. The application for EEC type-approval of a tractor with regard to the strength of a protection structure and the strength of its attachment to the tractor is submitted by the tractor manufacturer or by his authorized representative.
2. A tractor representative of the tractor type to be approved, on which a protection structure and its attachment, duly approved, are mounted, must be submitted to the technical services responsible for conducting the type-approval tests.
3. The technical service responsible for conducting the type-approval tests checks whether the approved type of protection structure is intended to be mounted on the type of tractor for which the type-approval is requested. In particular, it must ascertain that the attachment of the protection structure corresponds to that which was used when the EEC component type-approval was granted.
4. The holder of the EEC type-approval may ask for its extension for other types of protection structures.
5. The competent authorities grant such extension on the following conditions:
 - 5.1. The new type of protection structure and its tractor attachment must have received EEC component type-approval.
 - 5.2. It is designed to be mounted on the type of tractor for which the extension of the EEC type-approval is requested.
 - 5.3. The attachment of the protection structure to the tractor must correspond to that which was tested when EEC component type-approval was granted.
6. A certificate, of which a model is shown in Annex X, is annexed to the EEC type-approval certificate for each type-approval or type-approval extension which has been granted or refused.
7. If the application for EEC type-approval for a type of tractor is introduced at the same time as the request for EEC component type-approval for a type of roll-over protection structure intended to be mounted on the type of tractor for which EEC type-approval is requested, the checks laid down in 2 and 3 are not applicable.

ANNEX X

MODEL

Name of competent authority

ANNEX TO THE EEC TYPE-APPROVAL CERTIFICATE FOR A TRACTOR TYPE WITH REGARD TO THE STRENGTH OF PROTECTION STRUCTURES (FRONT-MOUNTED BAR) AND THE STRENGTH OF THEIR ATTACHMENT TO THE TRACTOR

(Articles 4 (2) and 10 of Council Directive 74/150/EEC of 4 March 1974 on the approximation of the laws of the Member States relating to the type-approval of wheeled agricultural or forestry tractors)

EEC type-approval No: extension (1)

- 1. Trade name or mark of tractor:
2. Tractor type:
3. Name and address of tractor manufacturer:
4. If applicable, name and address of manufacturer's authorized representative:
5. Trade name or mark of protection structure:
6. Extension of EEC-approval for the following type(s) of protection structure:
7. Date tractor submitted for EEC type-approval:
8. Technical service responsible for EEC type-approval conformity control:
9. Date of report issued by that service:
10. Number of report issued by that service:
11. EEC type-approval with regard to the strength of the protection structures and the strength of their attachment to the tractor has been granted/refused (2)
12. The extension of EEC type-approval with regard to the strength of the protection structures and the strength of their attachment to the tractor has been granted/refused (2)
13. Place:
14. Date:
15. Signature:

(1) If applicable, state whether this is the first, second, etc. extension of the original EEC type-approval.
(2) Delete where inapplicable.