





**COMMISSION DELEGATED REGULATION (EU) 2019/2015**

**of 11 March 2019**

**supplementing Regulation (EU) 2017/1369 of the European Parliament and of the Council with regard to energy labelling of light sources and repealing Commission Delegated Regulation (EU) No 874/2012**

(Text with EEA relevance)

*Article 1*

**Subject matter and scope**

1. This Regulation establishes requirements for the labelling of, and the provision of supplementary product information on, light sources with or without integrated control gear. The requirements also apply to light sources placed on the market in a containing product.
2. This Regulation shall not apply to light sources specified in points 1 and 2 of Annex IV.
3. Light sources specified in point 3 of Annex IV shall comply only with the requirements in point 4 of Annex V.

*Article 2*

**Definitions**

For the purposes of this Regulation, the following definitions shall apply:

- (1) ‘light source’ means an electrically operated product intended to emit, or, in the case of a non-incandescent light source, intended to be possibly tuned to emit, light, or both, with all of the following optical characteristics:
  - (a) chromaticity coordinates  $x$  and  $y$  in the range:
 
$$0,270 < x < 0,530; \text{ and}$$

$$- 2,3172 x^2 + 2,3653 x - 0,2199 < y < - 2,3172 x^2 + 2,3653 x - 0,1595;$$
  - (b) a luminous flux  $< 500$  lumen per  $\text{mm}^2$  of projected light-emitting surface area as defined in Annex I;
  - (c) a luminous flux between 60 and 82 000 lumen;
  - (d) a colour rendering index (CRI)  $> 0$ ;

using incandescence, fluorescence, high-intensity discharge, inorganic light emitting diodes (LED) or organic light emitting diodes (OLED), or their combinations as lighting technology, and that can be verified as a light source according to the procedure of Annex IX.

**▼ B**

High-pressure sodium (HPS) light sources that do not fulfil condition (a) are considered light sources for the purposes of this Regulation.

Light sources do not include:

- (a) LED dies or LED chips;
  - (b) LED packages;
  - (c) products containing light source(s) from which these light source(s) can be removed for verification;
  - (d) light-emitting parts contained in a light source from which these parts cannot be removed for verification as a light source.
- (2) ‘control gear’ means one or more devices that may or may not be physically integrated in a light source, intended to prepare the mains for the electric format required by one or more specific light sources within boundary conditions set by electric safety and electromagnetic compatibility. It may include transforming the supply and starting voltage, limiting operational and preheating current, preventing cold starting, correcting the power factor and/or reducing radio interference

The term ‘control gear’ does not include power supplies within the scope of Commission Regulation (EC) No 278/2009 <sup>(1)</sup>. The term also does not include lighting control parts and non-lighting parts (as defined in Annex I), although such parts may be physically integrated with a control gear or marketed together as a single product.

A Power over Ethernet (PoE) switch is not a control gear in the sense of this Regulation. ‘Power-over-Ethernet switch’ or ‘PoE switch’ means equipment for power-supply and data-handling that is installed between the mains and office equipment and/or light sources for the purpose of data transfer and power supply;

**▼ M1**

- (3) ‘containing product’ means a product containing one or more light sources, or separate control gears, or both, including, but not limited to, luminaires that can be taken apart to allow separate verification of the contained light source(s), household appliances containing light source(s), furniture (shelves, mirrors, display cabinets) containing light source(s);

**▼ B**

- (4) ‘light’ means electromagnetic radiation with a wavelength between 380 nm and 780 nm;
- (5) ‘mains’ or ‘mains voltage’ (MV) means the electricity supply of 230 (± 10 %) volt of alternating current at 50 Hz;

<sup>(1)</sup> Commission Regulation (EC) No 278/2009 of 6 April 2009 implementing Directive 2005/32/EC of the European Parliament and of the Council with regard to ecodesign requirements for no-load condition electric power consumption and average active efficiency of external power supplies (OJ L 93, 7.4.2009, p. 3).

**▼ B**

- (6) ‘LED die’ or ‘LED chip’ means a small block of light-emitting semiconducting material on which a functional LED circuit is fabricated;
- (7) ‘LED package’ means a single electric part comprising principally at least one LED die. It does not include a control gear or parts of it, a cap or active electronic components and is not connected directly to the mains voltage. It can include one or more of the following: optical elements, light converters (phosphors), thermal, mechanical and electric interfaces or parts to address electrostatic discharge concerns. Any similar light-emitting devices that are intended to be used directly in an LED luminaire, are considered to be light sources;
- (8) ‘chromaticity’ means the property of a colour stimulus defined by its chromaticity coordinates (x and y);
- (9) ‘luminous flux’ or ‘flux’ ( $\Phi$ ), expressed in lumen (lm), means the quantity derived from radiant flux (radiant power) by evaluating the electromagnetic radiation in accordance with the spectral sensitivity of the human eye. It refers to the total flux emitted by a light source in a solid angle of  $4\pi$  steradians under conditions (e.g. current, voltage, temperature) specified in applicable standards. It refers to the initial flux for the undimmed light source after a short operating period, unless it is clearly specified that the flux in a dimmed condition or the flux after a given period of operation is intended. For light sources that can be tuned to emit different light spectra and/or different maximum light intensities, it refers to the flux in the ‘reference control settings’ as defined in Annex I;
- (10) ‘colour rendering index’ (CRI) means a metric quantifying the effect of an illuminant on the colour appearance of objects by conscious or subconscious comparison with their colour appearance under the reference illuminant and is the average Ra of the colour rendering for the first 8 test colours (R1-R8) defined in standards;
- (11) ‘incandescence’ means the phenomenon where light is produced from heat, in light sources typically produced through a threadlike conductor (‘filament’) which is heated by the passage of an electric current;
- (12) ‘halogen light source’ means an incandescent light source with a threadlike conductor made from tungsten surrounded by gas containing halogens or halogen compounds;
- (13) ‘fluorescence’ or ‘fluorescent light source’ (FL) means the phenomenon or a light source using an electric gas discharge of the low-pressure mercury type in which most of the light is emitted by one or more layers of phosphors excited by the ultra-violet radiation from the discharge. Fluorescent light sources may have one (‘single-capped’) or two (‘double-capped’) connections (‘caps’) to their electricity supply. For the purposes of this Regulation, magnetic induction light sources are also considered as fluorescent light sources;
- (14) ‘high intensity discharge’ (HID) means an electric gas discharge in which the light-producing arc is stabilised by wall temperature and the arc chamber has a bulb wall loading in excess of 3 watts per square centimetre. HID light sources are limited to metal halide, high-pressure sodium and mercury vapour types as defined in Annex I;

**▼B**

- (15) ‘gas discharge’ means a phenomenon where light is produced, directly or indirectly, by an electric discharge through a gas, plasma, metal vapour or mixture of gases and vapours;
- (16) ‘inorganic light emitting diode’ (LED) means a technology in which light is produced from a solid state device embodying a p-n junction of inorganic material. The junction emits optical radiation when excited by an electric current;
- (17) ‘organic light emitting diode’ (OLED) means a technology in which light is produced from a solid state device embodying a p-n junction of organic material. The junction emits optical radiation when excited by an electric current;
- (18) ‘high-pressure sodium light source’ (HPS) means a high intensity discharge light source in which the light is produced mainly by radiation from sodium vapour operating at a partial pressure of the order of 10 kilopascals. HPS light sources may have one (‘single-ended’) or two (‘double-ended’) connectors to their electricity supply;
- (19) ‘point of sale’ means a physical location where the product is displayed or offered for sale, hire or hire-purchase to the customer.

For the purposes of the Annexes, additional definitions are set out in Annex I.

*Article 3***Obligations of suppliers**

- 1. Suppliers of light sources shall ensure that:
  - (a) each light source which is placed on the market as an independent product (i.e. not in a containing product) and in packaging, is supplied with a label, printed on the packaging, in the format as set out in Annex III;

**▼M1**

- (b) the values of the parameters included in the product information sheet, as set out in Annex V, are entered into the public part of the product database;

**▼B**

- (c) if specifically requested by the dealer, the product information sheet shall be made available in printed form;
- (d) the content of the technical documentation, as set out in Annex VI, is entered into the product database;
- (e) any visual advertisement for a specific model of light source contains the energy efficiency class of that model and the range of energy efficiency classes available on the label, in accordance with Annex VII and Annex VIII;
- (f) any technical promotional material concerning a specific model of light source, including technical promotional material on the internet, which describes its specific technical parameters, includes the energy efficiency class of that model and the range of energy efficiency classes available on the label, in accordance with Annex VII;
- (g) an electronic label in the format and containing the information, as set out in Annex III, is made available to dealers for each light source model;
- (h) an electronic product information sheet, as set out in Annex V, is made available to dealers for each light source model;

**▼ M1**

- (i) by way of derogation from Article 11(13)(b) of Regulation (EU) 2017/1369, upon request by dealers and in accordance with Article 4(e), printed labels to rescale products are provided as a sticker, of the same size as the one which already exists.

1a. By way of derogation from Article 11(13)(a) of Regulation (EU) 2017/1369, the supplier shall, when placing a light source on the market, provide it with the existing label until 31 August 2021 and with the rescaled label from 1 September 2021. The supplier may choose to already provide light sources placed on the market during the period from 1 July to 31 August 2021 with the rescaled label, if no light sources belonging to the same model or equivalent models were placed on the market before 1 July 2021. In that case, the dealer shall not offer those light sources for sale before 1 September 2021. The supplier shall notify the dealer concerned of that consequence as soon as possible, including when it includes such light sources in its offers to dealers.

**▼ B**

- 2. Suppliers of containing products shall:
  - (a) provide information on the contained light source(s), as specified in point 2 of Annex V;
  - (b) upon request by market surveillance authorities, provide information on how light sources can be removed for verification without permanent damage to the light source.
- 3. The energy efficiency class shall be calculated in accordance with Annex II.

*Article 4***Obligations of dealers**

Dealers shall ensure that:

- (a) At the point of sale, each light source which is not in a containing product bears the label provided by suppliers in accordance with point 1(a) of Article 3, with the label or the energy class being displayed in such a way as to be clearly visible, in accordance with Annex III;
- (b) in the event of distance selling, the label and product information sheet are provided, in accordance with Annexes VII and VIII;
- (c) any visual advertisement for a specific model of light source, including on the internet, contains the energy efficiency class of that model and the range of energy efficiency classes available on the label, in accordance with Annex VII;
- (d) any technical promotional material concerning a specific model of light source, including technical promotional material on the internet, which describes its specific technical parameters includes the energy efficiency class of that model and the range of energy efficiency classes available on the label, in accordance with Annex VII;

**▼ M1**

- (e) by way of derogation from Article 11(13) of Regulation (EU) 2017/1369, existing labels on light sources at points of sale are replaced by the rescaled labels in such a way as to cover the existing label, including when printed on or attached to the package, within eighteen months after the date of application of this Regulation, and rescaled labels are not displayed before that date.

**▼B***Article 5***Obligations of internet hosting platforms**

Where a hosting service provider as referred to in Article 14 of Directive 2000/31/EC allows the selling of light sources through its internet site, the service provider shall enable the showing of the electronic label and electronic product information sheet provided by the dealer on the display mechanism in accordance with the provisions of Annex VIII and shall inform the dealer of the obligation to display them.

*Article 6***Measurement methods**

The information to be provided pursuant to Articles 3 and 4 shall be obtained by reliable, accurate and reproducible measurement and calculation methods, which take into account the recognised state-of-the-art measurement and calculation method, as set out in Annex II.

*Article 7***Verification procedure for market surveillance purposes**

Member States shall apply the verification procedure laid down in Annex IX when performing the market surveillance checks referred to in paragraph 3 of Article 8 of Regulation (EU) 2017/1369.

*Article 8***Review**

The Commission shall review this Regulation in the light of technological progress and present the results of this review, including, if appropriate, a draft revision proposal, to the Consultation Forum no later than 25 December 2024. The review shall among other matters assess the energy efficiency classes, methods to address the energy efficiency of light sources in containing products and the possibility to address circular economy aspects.

*Article 9***Repeal**

Delegated Regulation (EU) No 874/2012 is repealed with effect from 1 September 2021, with the exception of paragraph 2 of Article 3 and paragraph 2 of Article 4 which are repealed with effect from 25 December 2019.

*Article 10***Entry into force and application**

This Regulation shall enter into force on the twentieth day following that of its publication in the *Official Journal of the European Union*.

**▼M1**

It shall apply from 1 September 2021. However, point 1(b) of Article 3 shall apply from 1 May 2021, and point 2(a) of Article 3 shall apply from 1 March 2022.

**▼B**

This Regulation shall be binding in its entirety and directly applicable in all Member States.



## ANNEX I

**Definitions applicable for the Annexes**

The following definitions shall apply:

- (1) ‘mains light source’ (MLS) means a light source that can be operated directly on the mains electricity supply. Light sources that operate directly on the mains, and can also operate indirectly on the mains using a separate control gear, shall be considered to be mains light sources;
- (2) ‘non-mains light source’ (NMLS) means a light source that requires a separate control gear to operate on the mains;
- (3) ‘separate control gear’ means a control gear that is not physically integrated with a light source and is placed on the market as a separate product or as part of a containing product;
- (4) ‘directional light source’ (DLS) means a light source having at least 80 % of total luminous flux within a solid angle of  $\pi$  sr (corresponding to a cone with angle of 120°);
- (5) ‘non-directional light source’ (NDLS) means a light source that is not a directional light source;
- (6) ‘connected light source’ (CLS) means a light source including data-connection parts that are physically or functionally inseparable from the light emitting parts to maintain the ‘reference control settings’. The light source can have physically integrated data-connection parts in a single inseparable housing, or the light source can be combined with physically separate data-connection parts placed on the market together with the light source as a single product;
- (7) ‘data-connection parts’ means parts that perform any one of the following functions:
  - (a) reception or transmission of wired or wireless data signals and the processing thereof (used to control the light emission function and possibly otherwise);
  - (b) sensing and processing of the sensed signals (used to control the light emission function and possibly otherwise);
  - (c) a combination of these;
- (8) ‘colour-tuneable light source’ (CTLS) means a light source that can be set to emit light with a large variety of colours outside the range defined in Article 2 but can also be set to emit white light inside the range defined in Article 2 for which the light source is within the scope of this Regulation.

Tuneable-white light sources that can only be set to emit light with different correlated colour temperatures, within the range defined in Article 2, and dim-to-warm light sources that shift their white light output to lower correlated colour temperature when dimmed, simulating the behaviour of incandescent light sources, are not considered CTLS;



**▼B**

- (9) ‘excitation purity’ means a percentage computed for a CTLS set to emit light of a certain colour, using a procedure further defined in standards, by drawing a straight line on an (x and y) colour space graph from a point with colour coordinates  $x = 0,333$  and  $y = 0,333$  (achromatic stimulus; point (1), going through the point representing the (x and y) colour coordinates of the light source (point (2), and ending on the outer border of the colour space (locus; point (3). The excitation purity is computed as the distance between points 1 and 2 divided by the distance between points 1 and 3. The full length of the line represents 100 % colour purity (point on the locus). The achromatic stimulus point represents 0 % colour purity (white light);
- (10) ‘high-luminance light source’ (HLLS) means a LED light source with an average luminance greater than  $30 \text{ cd/mm}^2$  in the direction of peak intensity;
- (11) ‘luminance’ (in a given direction, at a given point of a real or imaginary surface) means the luminous flux transmitted by an elementary beam passing through the given point and propagating in the solid angle containing the given direction divided by the area of a section of that beam containing the given point ( $\text{cd/m}^2$ );
- (12) ‘average luminance’ (Luminance-HLLS) for a LED light source means the average luminance over a light-emitting area where the luminance is more than 50 % of the peak luminance ( $\text{cd/mm}^2$ );
- (13) ‘lighting control parts’ means parts that are integrated in a light source, or physically separated but marketed together with a light source as a single product, that are not strictly necessary for the light source to emit light at full-load, but that enable manual — or automatic-, direct- or remote-, control of luminous intensity, chromaticity, correlated colour temperature, light spectrum and/or beam angle. Dimmers shall also be considered as lighting control parts.

The term also includes data-connection parts, but the term does not include devices within the scope of Commission Regulation (EC) No 1275/2008 <sup>(1)</sup>;

- (14) ‘non-lighting parts’ means parts that are integrated in a light source, or physically separated but marketed together with a light source as a single product, that are not necessary for the light source to emit light at full-load, and that are not ‘lighting control parts’. Examples include, but are not limited to: speakers (audio), cameras, repeaters for communication signals to extend the range (e.g. WiFi), parts supporting grid balance (switching to own internal batteries when necessary), battery charging, visual notification of events (mail arriving, door bell ringing, alert), use of Light Fidelity (Li-Fi, a bidirectional, high-speed and fully networked wireless communication technology).

The term also includes data-connection parts used for other functions than to control the light emission function;

- (15) ‘useful luminous flux’ ( $\Phi_{\text{use}}$ ) means the part of the luminous flux of a light source that is considered when determining its energy efficiency:
- for non-directional light sources it is the total flux emitted in a solid angle of  $4\pi \text{ sr}$  (corresponding to a  $360^\circ$  sphere);
  - for directional light sources with beam angle  $\geq 90^\circ$  it is the flux emitted in a solid angle of  $\pi \text{ sr}$  (corresponding to a cone with angle of  $120^\circ$ );
  - for directional light sources with beam angle  $< 90^\circ$  it is the flux emitted in a solid angle of  $0,586\pi \text{ sr}$  (corresponding to a cone with angle of  $90^\circ$ );

<sup>(1)</sup> Commission Regulation (EC) No 1275/2008 of 17 December 2008 implementing Directive 2005/32/EC of the European Parliament and of the Council with regard to ecodesign requirements for standby and off mode electric power consumption of electrical and electronic household and office equipment (OJ L 339, 18.12.2008, p. 45).

**▼ B**

- (16) ‘beam angle’ of a directional light source means the angle between two imaginary lines in a plane through the optical beam axis, such that these lines pass through the centre of the front face of the light source and through points at which the luminous intensity is 50 % of the centre beam intensity, where the centre beam intensity is the value of luminous intensity measured on the optical beam axis.

For light sources that have different beam angles in different planes, the largest beam angle shall be the one taken into account;

For light sources with user-controllable beam angle, the beam angle corresponding to the ‘reference control setting’ shall be the one taken into account;

- (17) ‘full-load’ means the condition of a light source, within the declared operating conditions, in which it emits the maximum (undimmed) luminous flux;
- (18) ‘standby mode’ means the condition of a light source, where it is connected to the power supply but the light source is intentionally not emitting light, and the light source is awaiting a control signal to return to a state with light emission. Lighting control parts enabling the standby function shall be in their control mode. Non-lighting parts shall be disconnected or switched off or their power consumption shall be minimised following manufacturer’s instructions;
- (19) ‘networked standby mode’ means the condition of a CLS where it is connected to the power supply but the light source is intentionally not emitting light and is awaiting a remotely initiated trigger to return to a state with light emission. Lighting control parts shall be in their control mode. Non-lighting parts shall be disconnected or switched off or their power consumption shall be minimised following the manufacturer’s instructions;
- (20) ‘control mode’ means the condition of lighting control parts where they are connected to the light source and performing their functions in such a way that a control signal can be internally generated or a remotely initiated trigger can be received, by wire or wireless, and processed to lead to a change in the light emission of the light source;
- (21) ‘remotely initiated trigger’ means a signal that comes from outside the light source via a network;
- (22) ‘control signal’ means an analogue or digital signal transmitted to the light source wirelessly or wired either via voltage modulation in separate control cables or via a modulated signal in the supply voltage. The signal transmission is not through a network but e.g. from an internal source or from a remote control delivered with the product;
- (23) ‘network’ means a communication infrastructure with a topology of links, an architecture, including the physical components, organisational principles, communication procedures and formats (protocols);
- (24) ‘on-mode power’ ( $P_{on}$ ) expressed in watt, means the electric power consumption of a light source in full-load with all lighting control parts and non-lighting parts disconnected. If these parts cannot be disconnected they shall be switched off or their power consumption shall be minimised following the manufacturer’s instructions. In case of a NMLS that requires a separate control gear to operate,  $P_{on}$  can be measured directly on the input to the light source, or  $P_{on}$  is determined using a control gear with known efficiency, whose electric power consumption is subsequently subtracted from the measured mains power input value;
- (25) ‘standby power’ ( $P_{sb}$ ) expressed in watt, is the electric power consumption of a light source in standby mode;

**▼ B**

- (26) ‘networked standby power’ ( $P_{\text{net}}$ ) expressed in watt, is the electric power consumption of a CLS in networked standby mode;
- (27) ‘reference control settings’ (RCS) means a control setting or a combination of control settings that is used to verify compliance of a light source with this Regulation. These settings are relevant for light sources that allow the end-user to control, manually or automatically, directly or remotely, the luminous intensity, colour, correlated colour temperature, spectrum, and/or beam angle of the emitted light.

In principle, the reference control settings shall be those predefined by the manufacturer as factory default values, and encountered by the user at first installation (out-of-the-box values). If the installation procedure provides for an automatic software update during first installation, or if the user has the option to perform such an update, the resulting change in settings (if any) shall be taken into account.

If the out-of-the-box value is deliberately set differently to the reference control setting (e.g. at low power for safety purposes), the manufacturer shall indicate in the technical documentation how to recall the reference control settings for compliance verification and provide a technical justification why the out-of-the-box value is set differently to the reference control setting.

The light source manufacturer shall define the reference control settings such that:

- the light source is within the scope of this Regulation according to Article 1 and none of the conditions for exemption applies;
- lighting control parts and non-lighting parts are disconnected or switched-off, or, in case this is not possible, the power consumption of these parts is minimal;
- the full-load condition is obtained;
- when the end-user opts to reset factory defaults, the reference control settings are obtained.

For light sources that allow the manufacturer of a containing product to make implementation choices that influence light source characteristics (e.g. definition of the operating current(s); thermal design), and that cannot be controlled by the end-user, the reference control settings need not be defined. In that case the nominal test conditions as defined by the light source manufacturer apply;

- (28) ‘high-pressure mercury light source’ means a high intensity discharge light source in which the major portion of light is produced, directly or indirectly, by radiation from predominantly vaporised mercury operating at a partial pressure in excess of 100 kilopascals;
- (29) ‘metal halide light source’ (MH) means a high intensity discharge light source in which the light is produced by radiation from a mixture of metallic vapour, metal halides and the products of the dissociation of metal halides. MH light sources may have one (‘single-ended’) or two (‘double-ended’) connectors to their electricity supply. The material for the arc tube of MH light sources can be quartz (QMH) or ceramic (CMH);
- (30) ‘compact fluorescent light source’ (CFL) means a single-capped fluorescent light source with a bent-tube construction designed to fit in small spaces. CFLs may be primarily spiral-shaped (i.e. curly forms) or primarily shaped as connected multiple parallel tubes, with or without a second bulb-like envelope. CFLs are available with (CFLi) or without (CFLni) physically integrated control gear;

**▼ B**

- (31) ‘T2’, ‘T5’, ‘T8’, ‘T9’ and ‘T12’ means a tubular light source with diameter of approximately 7, 16, 26, 29 and 38 mm respectively, as defined in standards. The tube can be straight (linear) or bent (e.g. U-shaped, circular);
- (32) ‘LFL T5-HE’ means a high-efficiency linear fluorescent T5 light source with driving current lower than 0,2 A;
- (33) ‘LFL T5-HO’ means a high-output linear fluorescent T5 light source with driving current higher than or equal to 0,2 A;
- (34) ‘HL R7s’ means a mains-voltage, double-capped, linear halogen light source with a cap diameter of 7 mm;
- (35) ‘battery-operated’ means a product that operates only on direct current (DC) supplied from a source contained in the same product, without being connected directly or indirectly to the mains electricity supply;
- (36) ‘second envelope’ means a second outer envelope on a HID light source that is not required for the production of light, such as an external sleeve for preventing mercury and glass release into the environment in case of lamp breakage. In determining the presence of a second envelope, the HID arc tubes shall not count as an envelope;
- (37) ‘non-clear envelope’ for a HID light source means a non-transparent outer envelope or outer tube in which the light producing arc tube is not visible;
- (38) ‘anti-glare shield’ means a mechanical or optical reflective or non-reflective impervious baffle designed to block direct visible radiation emitted from the light emitter in a directional light source, in order to avoid temporary partial blindness (disability glare) if viewed directly by an observer. It does not include surface coating of the light emitter in the directional light source;
- (39) ‘flicker’ means the perception of visual unsteadiness induced by a light stimulus, the luminance or spectral distribution of which fluctuates with time, for a static observer in a static environment. The fluctuations can be periodic and non-periodic and may be induced by the light source itself, the power source or other influencing factors.

The metric for flicker used in this Regulation is the parameter ‘Pst LM’, where ‘st’ stands for short term and ‘LM’ for light flickermeter method, as defined in standards. A value Pst LM = 1 means that the average observer has a 50 % probability of detecting flicker;

- (40) ‘stroboscopic effect’ means a change in motion perception induced by a light stimulus the luminance or spectral distribution of which fluctuates with time, for a static observer in a non-static environment. The fluctuations can be periodic and non-periodic and may be induced by the light source itself, the power source or other influencing factors.

The metric for the stroboscopic effect used in this Regulation is ‘SVM’ (stroboscopic visibility measure), as defined in standards. SVM = 1 represents the visibility threshold for an average observer;

- (41) ‘R9’ means the colour rendering index for a red coloured object as defined in standards;

**▼ M1**

- (42) ‘declared values’ means the values provided by the supplier for the stated, calculated or measured technical parameters, pursuant to Article 3(3) of Regulation (EU) 2017/1369 and in accordance with Article 3(1)(d) and Annex VI of this Regulation, for the verification of compliance by the Member State authorities;

**▼ B**

- (43) ‘luminous intensity’ (candela or cd) means the quotient of the luminous flux leaving the source and propagated in the element of solid angle containing a given direction, by the element of solid angle;

**▼ B**

- (44) ‘correlated colour temperature’ (CCT [K]) means the temperature of a Planckian (black body) radiator whose perceived colour most closely resembles that of a given stimulus at the same brightness and under specified viewing conditions;
- (45) ‘colour consistency’ means the maximum deviation of the initial (after a short period of time), spatially averaged chromaticity coordinates (x and y) of a single light source from the chromaticity centre point (cx and cy) declared by the manufacturer or the importer, expressed as the size (in steps) of the MacAdam ellipse formed around the chromaticity centre point (cx and cy);
- (46) ‘displacement factor (cos  $\phi_1$ )’ means the cosine of the phase angle  $\phi_1$  between the fundamental harmonic of the mains supply voltage and the fundamental harmonic of the mains current. It is used for mains light sources using LED- or OLED-technology. The displacement factor is measured at full-load, for the reference control settings where applicable, with any lighting control parts in control mode and non-lighting parts disconnected, switched off or set to minimum power consumption according to the manufacturer’s instructions;
- (47) ‘lumen maintenance factor’ ( $X_{LMF}$ ) means the ratio of the luminous flux emitted by a light source at a given time in its life to the initial luminous flux;
- (48) ‘survival factor’ (SF) means the defined fraction of the total number of light sources that continue to operate at a given time under defined conditions and switching frequency;
- (49) ‘lifetime’ for LED and OLED light sources means the time in hours between the start of their use and the moment when for 50 % of a population of light sources the light output has gradually degraded to a value below 70 % of the initial luminous flux. This is also referred to as the  $L_{70B_{50}}$  lifetime;
- (50) ‘display mechanism’ means any screen, including tactile screen, or other visual technology used for displaying internet content to users;
- (51) ‘tactile screen’ means a screen responding to touch, such as that of a tablet computer, slate computer or a smartphone;
- (52) ‘nested display’ means visual interface where an image or data set is accessed by a mouse click, mouse roll-over or tactile screen expansion of another image or data set;
- (53) ‘alternative text’ means text provided as an alternative to a graphic allowing information to be presented in non- graphical form where display devices cannot render the graphic or as an aid to accessibility such as input to voice synthesis applications;
- (54) ‘projected light-emitting surface area’ (A) is the surface area in  $\text{mm}^2$  (square millimetres) of the view in an orthographic projection of the light-emitting surface from the direction with the highest light intensity, where the light-emitting surface area is the surface area of the light source that emits light with the declared optical characteristics, such as the approximately spherical surface of an arc (a), cylindrical surface of a filament coil (b) or a gas discharge lamp (c, d), flat or semi-spherical envelope of a light-emitting diode (e).

For light sources with a non-clear envelope or with anti-glare shield, the light-emitting surface area is the entire area through which light leaves the light source.

For light sources containing more than one light emitter, the projection of the smallest gross volume enveloping all emitters shall be taken as the light-emitting surface.

▼ B

For HID light sources definition (a) applies, unless the dimensions defined in (d) apply with  $L > D$ , where  $L$  is the distance between the electrode tips and  $D$  the inner diameter of the arc tube.

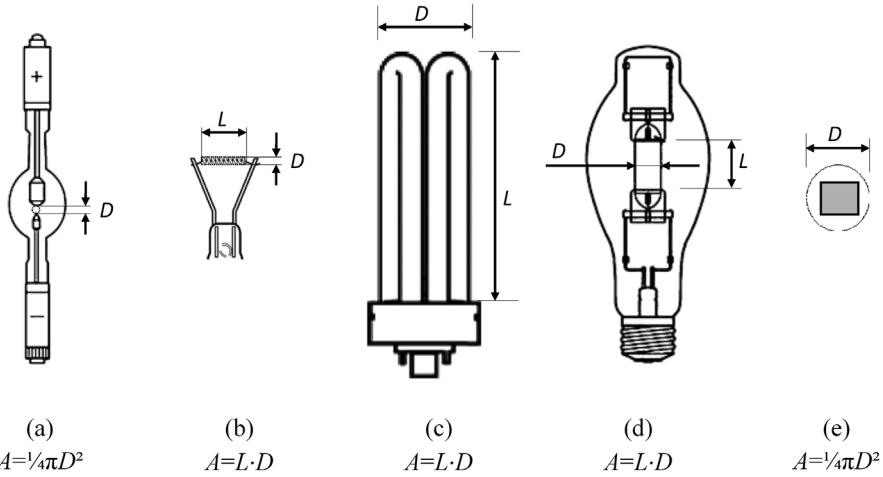

- (55) 'quick response' (QR) code means a matrix barcode included on the energy label of a product model that links to that model's information in the public part of the product database.



## ANNEX II

## Energy efficiency classes and calculation method

The energy efficiency class of light sources shall be determined as set out in Table 1, on the basis of the total mains efficacy  $\eta_{TM}$ , which is calculated by dividing the declared useful luminous flux  $\Phi_{use}$  (expressed in  $lm$ ) by the declared on-mode power consumption  $P_{on}$  (expressed in  $W$ ) and multiplying by the applicable factor  $F_{TM}$  of Table 2, as follows:

$$\eta_{TM} = (\Phi_{use}/P_{on}) \times F_{TM} \text{ (lm/W)}.$$

Table 1

## Energy efficiency classes of light sources

Energy efficiency class	Total mains efficacy $\eta_{TM}$ (lm/W)
A	$210 \leq \eta_{TM}$
B	$185 \leq \eta_{TM} < 210$
C	$160 \leq \eta_{TM} < 185$
D	$135 \leq \eta_{TM} < 160$
E	$110 \leq \eta_{TM} < 135$
F	$85 \leq \eta_{TM} < 110$
G	$\eta_{TM} < 85$

Table 2

Factors  $F_{TM}$  by light source type

Light source type	Factor $F_{TM}$
Non-directional (NDLS) operating on mains (MLS)	1,000
Non-directional (NDLS) not operating on mains (NMLS)	0,926
Directional (DLS) operating on mains (MLS)	1,176
Directional (DLS) not operating on mains (NMLS)	1,089

**▼B***ANNEX III***Label for light sources**

## 1. LABEL

If the light source is intended to be marketed through a point of sale, a label produced in the format and containing information as set out in this Annex is printed on the individual packaging.

Suppliers shall choose a label format between point 1.1 and point 1.2 of this Annex.

**▼M1**

The label shall be:

- for the standard-sized label, at least 36 mm wide and 72 mm high,
- for the small-sized label (width less than 36 mm), at least 20 mm wide and 54 mm high.

**▼B**

The packaging shall not be smaller than 20 mm wide and 54 mm high.

Where the label is printed in a larger format, its content shall nevertheless remain proportionate to the specifications above. The small-sized label shall not be used on packaging with a width of 36 mm or more.

The label and the arrow indicating the energy efficiency class may be printed in monochrome as specified in points 1.1 and 1.2, only if all other information, including graphics, on the packaging is printed in monochrome.

If the label is not printed on the part of the packaging meant to face the prospective customer, an arrow containing the letter of the energy efficiency class shall be displayed as hereafter, with the colour of the arrow matching the letter and the colour of the energy class. The size shall be such that the label is clearly visible and legible. The letter in the energy efficiency class arrow shall be Calibri Bold and positioned in the centre of the rectangular part of the arrow, with a border of 0,5 pt in 100 % black placed around the arrow and the letter of the efficiency class.

*Figure 1*

**Coloured/monochrome left/right arrow for the part of the packaging facing the prospective customer**



In the case referred to in point (e) of Article 4 the rescaled label shall have a format and size that permits it to cover and adhere to the old label.



▼ **B**

## 1.1. Standard-sized label:

The label shall be:

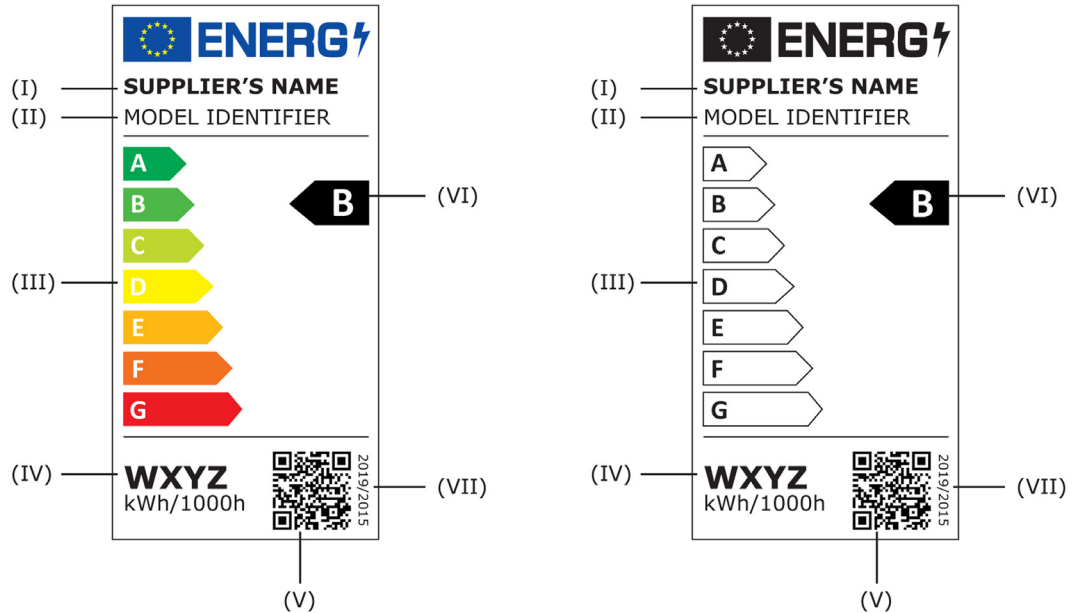

## 1.2. Small-sized label:

The label shall be:

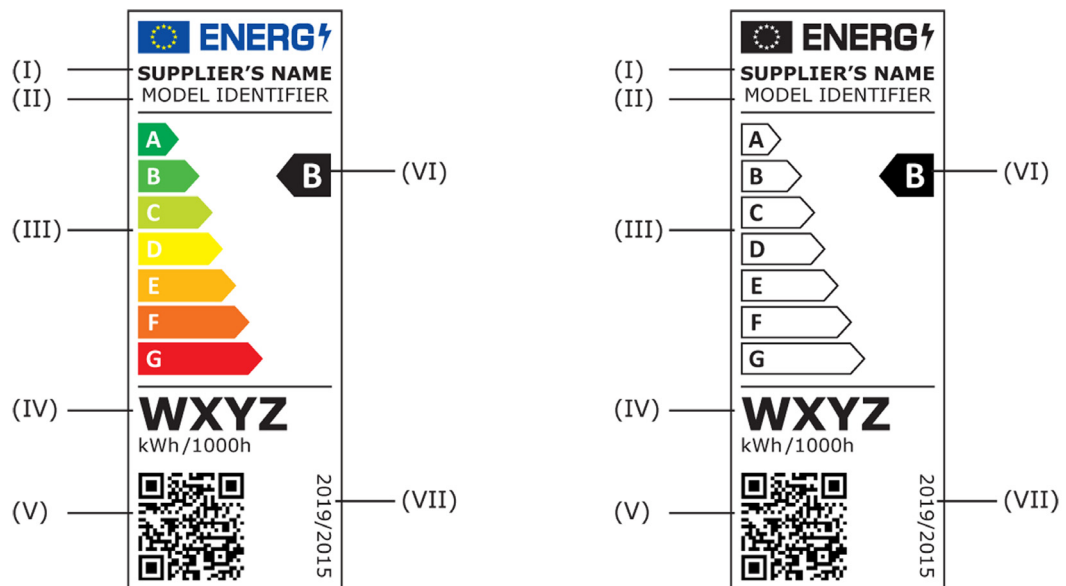

## 1.3. The following information shall be included in the label for light sources:

- I. supplier's name or trade mark;
- II. supplier's model identifier;
- III. scale of energy efficiency classes from A to G;
- IV. the energy consumption, expressed in kWh of electricity consumption per 1 000 hours, of the light source in on-mode;
- V. QR-code;
- VI. the energy efficiency class in accordance with Annex II;
- VII. the number of this Regulation that is '2019/2015'.

**▼ B**

2. LABEL DESIGNS

2.1. Standard-sized label:

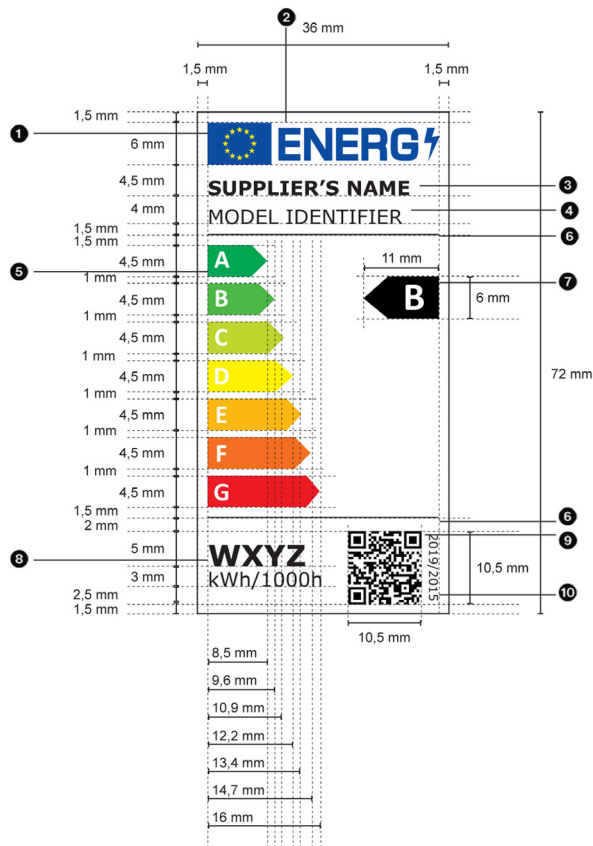

2.2. Small-sized label:

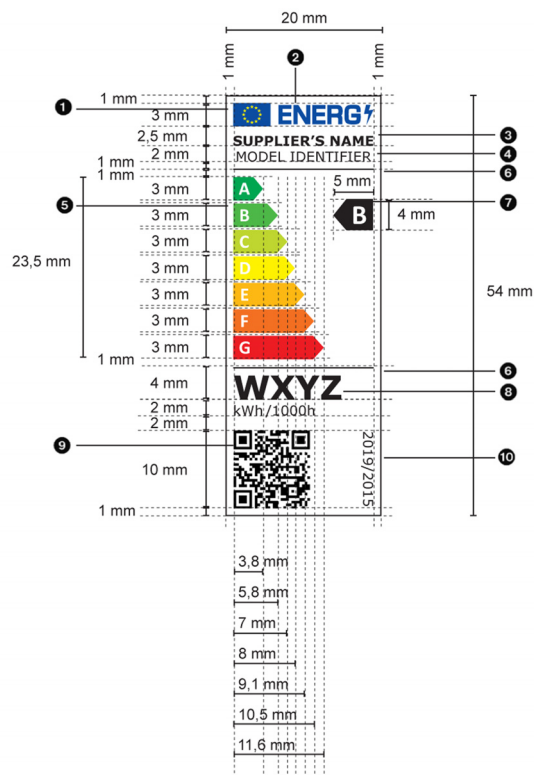

**▼ B**

## 2.3. Whereby:

- (a) The dimensions and specifications of the elements constituting the labels shall be as indicated in paragraph 1 of Annex III and in the label designs for standard-sized and small sized labels for light sources.
- (b) The background of the label shall be 100 % white.
- (c) The typefaces shall be Verdana and Calibri.
- (d) Colours shall be CMYK – cyan, magenta, yellow and black, following this example: 0-70-100-0: 0 % cyan, 70 % magenta, 100 % yellow, 0 % black.
- (e) The labels shall fulfil all the following requirements (numbers refer to the figures above):
  - ① the colours of the EU logo shall be as follows:
    - the background: 100,80,0,0;
    - the stars: 0,0,100,0;
  - ② the colour of the energy logo shall be: 100,80,0,0;
  - ③ the supplier's name shall be 100 % black and in Verdana Bold 8 pt – 5 pt (standard-sized – small-sized label);
  - ④ the model identifier shall be 100 % black and in Verdana Regular 8 pt – 5 pt (standard-sized – small-sized label);
  - ⑤ the A to G scale shall be as follows:
    - the letters of the energy efficiency scale shall be 100 % white and in Calibri Bold 10,5 pt – 7 pt (standard-sized – small-sized label); the letters shall be centred on an axis at 2 mm - 1,5 mm (standard-sized – small-sized label) from the left side of the arrows;
    - the colours of A to G scale arrows shall be as follows:
      - A-class: 100,0,100,0;
      - B-class: 70,0,100,0;
      - C-class: 30,0,100,0;
      - D-class: 0,0,100,0;
      - E-class: 0,30,100,0;
      - F-class: 0,70,100,0;
      - G-class: 0,100,100,0;

**▼ M1**

- ⑥ the rectangular border of the label and the internal dividers shall have a weight of 0,5 pt and the colour shall be 100 % black;

**▼ B**

- ⑦ the letter of the energy efficiency class shall be 100 % white and in Calibri Bold 16 pt – 10 pt (standard-sized – small-sized label). The energy efficiency class arrow and the corresponding arrow in the A to G scale shall be positioned in such a way that their tips are aligned. The letter in the energy efficiency class arrow shall be positioned in the centre of the rectangular part of the arrow which shall be 100 % black;

**▼ B**

- ⑧ the energy consumption value shall be in Verdana Bold 12 pt; 'kWh/1 000h' shall be in Verdana Regular 8 pt – 5 pt (standard-sized – small-sized label), 100 % black;
- ⑨ the QR code shall be 100 % black;
- ⑩ the number of the regulation shall be 100 % black and in Verdana Regular 5 pt.

**▼B***ANNEX IV***Exemptions**

1. This Regulation shall not apply to light sources specifically tested and approved to operate:

**▼MI**

(a) in radiological and nuclear medicine installations that are subject to radiation safety standards as set out in Council Directive 2013/59/Euratom <sup>(1)</sup>;

**▼B**

(b) for emergency use;

(c) in or on military or civil defence establishments, equipment, ground vehicles, marine equipment or aircraft as set out in Member States' regulations or in documents issued by the European Defence Agency;

(d) in or on motor vehicles, their trailers and systems, interchangeable towed equipment, components and separate technical units, as set out in Regulation (EC) No 661/2009 of the European Parliament and of the Council <sup>(2)</sup>, Regulation (EU) No 167/2013 of the European Parliament and of the Council <sup>(3)</sup> and Regulation (EU) No 168/2013 of the European Parliament and of the Council <sup>(4)</sup>;

(e) in or on non-road mobile machinery as set out in Regulation (EU) 2016/1628 of the European Parliament and of the Council <sup>(5)</sup> and in or on their trailers;

(f) in or on interchangeable equipment as set out in Directive 2006/42/EC of the European Parliament and of the Council <sup>(6)</sup> intended to be towed or to be mounted and fully raised from the ground or that cannot articulate around a vertical axis when the vehicle to which it is attached is in use on a road by vehicles as set out in Regulation (EU) No 167/2013;

(g) in or on civil aviation aircraft as set out in Commission Regulation (EU) No 748/2012 <sup>(7)</sup>;

(h) in railway vehicle lighting as set out in Directive 2008/57/EC of the European Parliament and of the Council <sup>(8)</sup>;

(i) in marine equipment as set out in Directive 2014/90/EU of the European Parliament and of the Council <sup>(9)</sup>;

<sup>(1)</sup> Council Directive 2013/59/Euratom of 5 December 2013 laying down basic safety standards for protection against the dangers arising from exposure to ionising radiation (OJ L 13, 17.1.2014, p. 1).

<sup>(2)</sup> Regulation (EC) No 661/2009 of the European Parliament and of the Council of 13 July 2009 concerning type-approval requirements for the general safety of motor vehicles, their trailers and systems, components and separate technical units intended therefor (OJ L 200, 31.7.2009, p. 1).

<sup>(3)</sup> Regulation (EU) No 167/2013 of the European Parliament and of the Council of 5 February 2013 on the approval and market surveillance of agricultural and forestry vehicles (OJ L 60, 2.3.2013, p. 1).

<sup>(4)</sup> Regulation (EU) No 168/2013 of the European Parliament and of the Council of 15 January 2013 on the approval and market surveillance of two- or three-wheel vehicles and quadricycles (OJ L 60, 2.3.2013, p. 52).

<sup>(5)</sup> Regulation (EU) 2016/1628 of the European Parliament and of the Council of 14 September 2016 on requirements relating to gaseous and particulate pollutant emission limits and type-approval for internal combustion engines for non-road mobile machinery, amending Regulations (EU) No 1024/2012 and (EU) No 167/2013, and amending and repealing Directive 97/68/EC (OJ L 252, 16.9.2016, p. 53).

<sup>(6)</sup> Directive 2006/42/EC of the European Parliament and of the Council of 17 May 2006 on machinery, and amending Directive 95/16/EC (recast) (OJ L 157, 9.6.2006, p. 24).

<sup>(7)</sup> Commission Regulation (EU) No 748/2012 of 3 August 2012 laying down implementing rules for the airworthiness and environmental certification of aircraft and related products, parts and appliances, as well as for the certification of design and production organisations (OJ L 224, 21.8.2012, p. 1).

<sup>(8)</sup> Directive 2008/57/EC of the European Parliament and of the Council of 17 June 2008 on the interoperability of the rail system within the Community (Recast) (OJ L 191, 18.7.2008, p. 1).

<sup>(9)</sup> Directive 2014/90/EU of the European Parliament and of the Council of 23 July 2014 on marine equipment and repealing Council Directive 96/98/EC (OJ L 257, 28.8.2014, p. 146).

**▼ B**

- (j) in medical devices as set out in Council Directive 93/42/EEC<sup>(10)</sup> or Regulation (EU) 2017/745 of the European Parliament and of the Council<sup>(11)</sup> and in vitro medical devices as set out in Directive 98/79/EC of the European Parliament and of the Council<sup>(12)</sup>.

For the purpose of this point, ‘specifically tested and approved’ means that the light source:

- has been specifically tested for the mentioned operating condition or application, according to the European legislation mentioned or related implementing measures, or relevant European or international standards or, in the absence of these, according to relevant Member States legislation; and
- is accompanied by evidence, to be included in the technical documentation, in the form of a certificate, a type approval mark, a test report, that the product has been specifically approved for the mentioned operating condition or application; and
- is placed on the market specifically for the mentioned operating condition or application, as evidenced at least by the technical documentation, and except for point (d), information on the packaging and any advertising or marketing materials.

2. In addition, this Regulation shall not apply to:

- (a) electronic displays (e.g. televisions, computer monitors, notebooks, tablets, mobile phones, e-readers, game consoles), including but not limited to displays within the scope of Commission Regulation (EU) 2019/2021<sup>(13)</sup> and of Commission Regulation (EU) No 617/2013<sup>(14)</sup>;
- (b) light sources in range hoods within the scope of Commission Delegated Regulation (EU) No 65/2014<sup>(15)</sup>;
- (c) light sources in battery-operated products, including but not limited to e.g. torches, mobile phones with an integrated torch light, toys including light sources, desk lamps operating only on batteries, armband lamps for cyclists, solar-powered garden lamps;
- (d) light sources on bicycles and other non-motorised vehicles;
- (e) light sources for spectroscopy and photometric applications, such as for example UV-VIS spectroscopy, molecular spectroscopy, atomic absorption spectroscopy, nondispersive infrared (NDIR), fourier-transform infrared (FTIR), medical analysis, ellipsometry, layer thickness measurement, process monitoring or environmental monitoring.

<sup>(10)</sup> Council Directive 93/42/EEC of 14 June 1993 concerning medical devices (OJ L 169, 12.7.1993, p. 1).

<sup>(11)</sup> Regulation (EU) 2017/745 of the European Parliament and of the Council of 5 April 2017 on medical devices, amending Directive 2001/83/EC, Regulation (EC) No 178/2002 and Regulation (EC) No 1223/2009 and repealing Council Directives 90/385/EEC and 93/42/EEC (OJ L 117, 5.5.2017, p. 1).

<sup>(12)</sup> Directive 98/79/EC of the European Parliament and of the Council of 27 October 1998 on in vitro diagnostic medical devices (OJ L 331, 7.12.1998, p. 1).

<sup>(13)</sup> Commission Regulation (EU) 2019/2021 of 1 October 2019 laying down ecodesign requirements for electronic displays pursuant to Directive 2009/125/EC of the European Parliament and of the Council, amending Commission Regulation (EC) No 1275/2008 and repealing Commission Regulation (EC) 642/2009 (see page 241 of this Official Journal).

<sup>(14)</sup> Commission Regulation (EU) No 617/2013 of 26 June 2013 implementing Directive 2009/125/EC of the European Parliament and of the Council with regard to ecodesign requirements for computers and computer servers (OJ L 175, 27.6.2013, p. 13).

<sup>(15)</sup> Commission Delegated Regulation (EU) No 65/2014 of 1 October 2013 supplementing Directive 2010/30/EU of the European Parliament and of the Council with regard to the energy labelling of domestic ovens and range hoods (OJ L 29, 31.1.2014, p. 1).

**▼ B**

3. Any light source within the scope of this Delegated Regulation shall be exempt from the requirements of this Regulation, with the exception of the requirements set out in point 4 of Annex V, if it is specifically designed and marketed for its intended use in at least one of the following applications:
- (a) signalling (including, but not limited to, road-, railway-, marine- or air traffic- signalling, traffic control or airfield lamps);
  - (b) image capture and image projection (including, but not limited to, photocopying, printing (directly or in pre-processing), lithography, film and video projection, holography);
  - (c) light sources with specific effective ultraviolet power > 2 mW/klm and intended for use in applications requiring high UV-content;
  - (d) light sources with a peak radiation around 253,7 nm and intended for germicidal use (destruction of DNA);
  - (e) light sources emitting 5 % or more of total radiation power of the range 250-800 nm in the range of 250-315 nm and/or 20 % or more of total radiation power of the range 250-800 nm in the range of 315-400 nm, and intended for disinfection or fly trapping;
  - (f) light sources having the primary purpose to emit radiation around 185,1 nm and intended to be used for the generation of ozone;
  - (g) light sources emitting 40 % or more of total radiation power of the range 250-800 nm in the range of 400-480 nm, and intended for coral zooxanthellae symbioses;
  - (h) FL light sources emitting 80 % or more of total radiation power of the range 250-800 nm in the range of 250-400 nm, and intended for sun-tanning;
  - (i) HID light sources emitting 40 % or more of total radiation power of the range 250-800 nm in the range of 250-400 nm, and intended for sun-tanning;
  - (j) light sources with a photosynthetic efficacy > 1,2 µmol/J, and/or emitting 25 % or more of total radiation power of the range 250-800 nm in the range of 700-800 nm, and intended for use in horticulture;
  - (k) LED or OLED light sources, complying with the definition of ‘original works of art’ as defined in Directive 2001/84/EC of the European Parliament and of the Council<sup>(16)</sup>, made by the artist him/herself in a limited number below 10 pieces;

**▼ M1**

- (l) Incandescent light sources with blade contact-, metal lug-, cable-, litz wire-, metric thread-, pin base- or non-standard customised electrical interface, encasing made from quartz-glass tubes, specifically designed and exclusively marketed for industrial or professional electro-heating equipment (e.g. stretch blow-moulding process in PET-Industry, 3D-printing, photovoltaic and electronic manufacturing processes, drying or hardening of adhesives, inks, paints or coatings).
4. Light sources specifically designed and exclusively marketed for products in the scope of Commission Regulations (EU) 2019/2023, (EU) 2019/2022, (EU) No 932/2012 and (EU) 2019/2019, shall be exempt from the requirements of points 1(e)(7b), 1(e)(7c) and 1(e)(7d) of Annex VI to this Regulation.

<sup>(16)</sup> Directive 2001/84/EC of the European Parliament and of the Council of 27 September 2001 on the resale right for the benefit of the author of an original work of art (OJ L 272, 13.10.2001, p. 32).

**▼ B***ANNEX V***Product information****1. Product information sheet**

- 1.1. Pursuant to point 1(b) of Article 3, the supplier shall enter into the product database the information as set out in Table 3, including when the light source is a part in a containing product.

**▼ M1***Table 3***Product information sheet**

<b>Supplier's name or trade mark</b> <sup>(a)</sup> <sup>(c)</sup> :			
<b>Supplier's address</b> <sup>(a)</sup> <sup>(c)</sup> :			
<b>Model identifier</b> <sup>(c)</sup> :			
<b>Type of light source:</b>			
Lighting technology used:	[HL/LFL T5 HE/LFL T5 HO/CFLni/other FL/HPS/MH/ other HID/LED/ OLED/mixed/ other]	Non-directional or directional:	[NDLS/DLS]
Light source cap-type (or other electric interface)	[free text]		
Mains or non-mains:	[MLS/NMLS]	Connected light source (CLS):	[yes/no]
Colour-tuneable light source:	[yes/no]	Envelope:	[no/second/non-clear]
High luminance light source:	[yes/no]		
Anti-glare shield:	[yes/no]	Dimmable:	[yes/only with specific dimmers/no]
<b>Product parameters</b>			
Parameter	Value	Parameter	Value
<i>General product parameters:</i>			
Energy consumption in on-mode (kWh/1 000 h), <b>rounded up to the nearest integer</b>	x	Energy efficiency class	[A/B/C/D/E/F/G] <sup>(b)</sup>
Useful luminous flux ( $\Phi_{use}$ ), indicating if it refers to the flux in a sphere (360°), in a wide cone (120°) or in a narrow cone (90°)	x in [sphere/ wide cone/ narrow cone]	Correlated colour temperature, rounded to the nearest 100 K, or the range of correlated colour temperatures, rounded to the nearest 100 K, that can be set	[x/x...x/x or x (or x...)]



▼ **M1**

On-mode power ( $P_{on}$ ), expressed in W		x,x	Standby power ( $P_{sb}$ ), expressed in W and rounded to the second decimal	x,xx
Networked standby power ( $P_{net}$ ) for CLS, expressed in W and rounded to the second decimal		x,xx	Colour rendering index, rounded to the nearest integer, or the range of CRI-values that can be set	[x/x...x]
Outer dimensions <sup>(a)</sup> <sup>(e)</sup> without separate control gear, lighting control parts and non-lighting control parts, if any (millimetre)	Height	x	Spectral power distribution in the range 250 nm to 800 nm, at full-load	[graphic]
	Width	x		
	Depth	x		
Claim of equivalent power <sup>(c)</sup>		[yes/-]	If yes, equivalent power (W)	x
			Chromaticity coordinates (x and y)	0,xxx 0,xxx

**Parameters for directional light sources:**

Peak luminous intensity (cd)	x	Beam angle in degrees, or the range of beam angles that can be set	[x/x...x]
------------------------------	---	--	-----------

**Parameters for LED and OLED light sources:**

R9 colour rendering index value	x	Survival factor	x,xx
the lumen maintenance factor	x,xx		

**Parameters for LED and OLED mains light sources:**

displacement factor ( $\cos \phi_1$ )	x,xx	Colour consistency in McAdam ellipses	x
Claims that an LED light source replaces a fluorescent light source without integrated ballast of a particular wattage.	[yes/-] <sup>(d)</sup>	If yes then replacement claim (W)	x

▼ **M1**

Flicker metric (Pst LM)	x,x	Stroboscopic effect metric (SVM)	x,x
-------------------------	-----	----------------------------------	-----

(e) changes to these items shall not be considered relevant for the purposes of point 4 of Article 4 of Regulation (EU) 2017/1369.

(b) if the product database automatically generates the definitive content of this cell the supplier shall not enter these data.

(c) '-': not applicable;

'yes': an equivalence claim involving the power of a replaced light source type may be given only:

- for directional light sources, if the light source type is listed in Table 4 and if the luminous flux of the light source in a 90° cone ( $\Phi_{90^\circ}$ ) is not lower than the corresponding reference luminous flux in Table 4. The reference luminous flux shall be multiplied by the correction factor in Table 5. For LED light sources, it shall be in addition multiplied by the correction factor in Table 6,
- for non-directional light sources, the claimed equivalent incandescent light source power (in watt, rounded to the integer) shall be that corresponding in Table 7 to the luminous flux of the light source.

The intermediate values of both the luminous flux and the claimed equivalent light source power (in watt, rounded to the integer) shall be calculated by linear interpolation between the two adjacent values.

(d) '-': not applicable;

'yes': Claim that a LED light source replaces a fluorescent light source without integrated ballast of a particular wattage. This claim may be made only if:

- the luminous intensity in any direction around the tube axis does not deviate by more than 25 % from the average luminous intensity around the tube, and
  - the luminous flux of the LED light source is not lower than the luminous flux of the fluorescent light source of the claimed wattage. The luminous flux of the fluorescent light source shall be obtained by multiplying the claimed wattage with the minimum luminous efficacy value corresponding to the fluorescent light source in Table 8, and
  - the wattage of the LED light source is not higher than the wattage of the fluorescent light source it is claimed to replace.
- The technical documentation file shall provide the data to support such claims.

(e) this item shall not be considered relevant for the purpose of Article 2(6) of Regulation (EU) 2017/1369.



*Table 4*  
**Reference luminous flux for equivalence claims**

Extra-low voltage reflector type		
Type	Power (W)	Reference $\Phi_{90^\circ}$ (lm)
MR11 GU4	20	160
	35	300
MR16 GU 5.3	20	180
	35	300
	50	540
AR111	35	250
	50	390
	75	640
	100	785
Mains-voltage blown glass reflector type		
Type	Power (W)	Reference $\Phi_{90^\circ}$ (lm)
R50/NR50	25	90
	40	170
R63/NR63	40	180
	60	300
R80/NR80	60	300
	75	350
	100	580
R95/NR95	75	350
	100	540
R125	100	580
	150	1 000
Mains-voltage pressed glass reflector type		
Type	Power (W)	Reference $\Phi_{90^\circ}$ (lm)
PAR16	20	90
	25	125
	35	200
	50	300
PAR20	35	200
	50	300
	75	500
PAR25	50	350
	75	550
PAR30S	50	350
	75	550
	100	750
PAR36	50	350

**▼ B**

	75	550
	100	720
PAR38	60	400
	75	555
	80	600
	100	760
	120	900

Table 5

**Multiplication factors for lumen maintenance**

Light source type	Luminous flux multiplication factor
Halogen light sources	1
Fluorescent light sources	1,08
LED light sources	$1 + 0,5 \times (1 - \text{LLMF})$ where LLMF is the lumen maintenance factor at the end of the declared lifetime

Table 6

**Multiplication factors for LED light sources**

LED light source beam angle	Luminous flux multiplication factor
$20^\circ \leq \text{beam angle}$	1
$15^\circ \leq \text{beam angle} < 20^\circ$	0,9
$10^\circ \leq \text{beam angle} < 15^\circ$	0,85
beam angle $< 10^\circ$	0,80

**▼ M1**

Table 7

**Equivalence claims for non-directional light sources**

Light source luminous flux $\Phi$ (lm)	Claimed equivalent incandescent light source power (W)
136	15
249	25
470	40
806	60
1 055	75
1 521	100
2 452	150
3 452	200



Table 8

## Minimum efficacy values for T8 and T5 light sources

T8 (26 mm Ø)		T5 (16 mm Ø) High Efficiency		T5 (16 mm Ø) High Output	
Claimed equivalent power (W)	Minimum luminous efficacy (lm/W)	Claimed equivalent power (W)	Minimum luminous efficacy (lm/W)	Claimed equivalent power (W)	Minimum luminous efficacy (lm/W)
15	63	14	86	24	73
18	75	21	90	39	79
25	76	28	93	49	88
30	80	35	94	54	82
36	93			80	77
38	87				
58	90				
70	89				

For light sources that can be tuned to emit light at full-load with different characteristics, the values of parameters that vary with these characteristics shall be reported at the reference control settings.

If the light source is no longer placed on the EU market, the supplier shall put in the product database the date (month, year) when the placing on the EU market stopped.

**2. Information to be displayed in the documentation for a containing product**

If a light source is placed on the market as a part in a containing product, the technical documentation for the containing product shall clearly identify the contained light source(s), including the energy efficiency class.

If a light source is placed on the market as a part in a containing product, the following text shall be displayed, clearly legible, in the user manual or booklet of instructions:

‘This product contains a light source of energy efficiency class <X>’,

where <X> shall be replaced by the energy efficiency class of the contained light source.

If the product contains more than one light source, the sentence can be in the plural, or repeated per light source, as suitable.

**3. Information to be displayed on the supplier’s free access website:**

- (a) The reference control settings, and instructions on how they can be implemented, where applicable;
- (b) Instructions on how to remove lighting control parts and/or non-lighting parts, if any, or how to switch them off or minimize their power consumption;
- (c) If the light source is dimmable: a list of dimmers it is compatible with, and the light source — dimmer compatibility standard(s) it is compliant with, if any;
- (d) If the light source contains mercury: instructions on how to clean up the debris in case of accidental breakage;
- (e) Recommendations on how to dispose of the light source at the end of its life in line with Directive 2012/19/EU of the European Parliament and of the Council <sup>(1)</sup>.

<sup>(1)</sup> Directive 2012/19/EU of the European Parliament and of the Council of 4 July 2012 on waste electrical and electronic equipment (WEEE) (OJ L 197, 24.7.2012, p. 38).

**▼B****4. Information for products specified in point 3 of Annex IV**

For the light sources specified in point 3 of Annex IV, their intended use shall be stated on all forms of packaging, product information and advertisement, together with a clear indication that the light source is not intended for use in other applications.

The technical documentation file drawn up for the purposes of conformity assessment, in accordance with paragraph 3 of Article 3 of Regulation (EU) 2017/1369 shall list the technical parameters that make the product design specific to qualify for the exemption.

**▼B***ANNEX VI***Technical documentation**

1. The technical documentation referred to in point 1(d) of Article 3 shall include:

- (a) the name and address of the supplier;
- (b) supplier's model identifier;
- (c) the model identifier of all equivalent models already placed on the market;
- (d) identification and signature of the person empowered to bind the supplier;

**▼M1**

(e) the declared values for the following technical parameters; these values are considered as the declared values for the purpose of the verification procedure in Annex IX:

- (1) useful luminous flux ( $\Phi_{\text{use}}$ ) in lm;
- (2) colour rendering index (CRI);
- (3) on-mode power ( $P_{\text{on}}$ ) in W;
- (4) beam angle in degrees for directional light sources (DLS);
- (4a) peak luminous intensity in cd for directional light sources (DLS);
- (5) correlated colour temperature (CCT) in K;
- (6) standby power ( $P_{\text{sb}}$ ) in W, including when it is zero;
- (7) networked standby power ( $P_{\text{net}}$ ) in W for connected light sources (CLS);
- (7a) R9 colour rendering index value for LED and OLED light sources;
- (7b) survival factor for LED and OLED light sources;
- (7c) lumen maintenance factor for LED and OLED light sources;
- (7d) indicative lifetime L70B50 for LED and OLED light sources;
- (8) displacement factor ( $\cos \phi_1$ ) for LED and OLED mains light sources;
- (9) colour consistency in MacAdam ellipse steps for LED and OLED light sources;
- (10) luminance-HLLS in  $\text{cd}/\text{mm}^2$  (only for HLLS)
- (11) flicker metric (PstLM) for ►**M2** LED and OLED mains light sources ◄;
- (12) stroboscopic effect metric (SVM) for ►**M2** LED and OLED mains light sources ◄;
- (13) excitation purity, only for CTLS, for the following colours and dominant wavelength within the given range:

Colour	Dominant wave-length range
--------	----------------------------

Blue	440 nm – 490 nm
------	-----------------

Green	520 nm – 570 nm
-------	-----------------

Red	610 nm – 670 nm;
-----	------------------

**▼B**

- (f) the calculations performed with the parameters, including the determination of the energy efficiency class;
- (g) references to the harmonised standards applied or other standards used;
- (h) testing conditions if not described sufficiently in point (g);

**▼ B**

- (i) the reference control settings, and instructions on how they can be implemented, where applicable;
- (j) instructions on how to remove lighting control parts and/or non-lighting parts, if any, or how to switch them off or minimise their power consumption during light source testing;
- (k) specific precautions that shall be taken when the model is assembled, installed, maintained or tested.

**▼ M1**

2. The elements listed under point 1 shall also constitute the mandatory specific parts of the technical documentation that the supplier shall enter into the database, pursuant to point 5 of Article 12 of Regulation (EU) 2017/1369.





*ANNEX VII*

**Information to be provided in visual advertisements, in technical promotional material and in distance selling, except distance selling on the internet**

1. In visual advertisements, for the purposes of ensuring conformity with the requirements laid down in point 1(e) of Article 3 and point 1(c) of Article 4, the energy class and the range of efficiency classes available on the label shall be shown as set out in point 4 of this Annex.
2. In technical promotional material, for the purposes of ensuring conformity with the requirements laid down in point 1(f) of Article 3 and point 1(d) of Article 4, the energy class and the range of efficiency classes available on the label shall be shown as set out in point 4 of this Annex.
3. Any paper-based distance selling must show the energy class and the range of efficiency classes available on the label as set out in point 4 of this Annex.
4. The energy efficiency class and the range of energy efficiency classes shall be shown, as indicated in Figure 2, with:
  - (a) an arrow, containing the letter of the energy efficiency class in 100 % white, Calibri Bold and in a font size at least equivalent to that of the price, when the price is shown;
  - (b) the colour of the arrow matching the colour of the energy efficiency class;
  - (c) the range of available energy efficiency classes in 100 % black; and,
  - (d) the size shall be such that the arrow is clearly visible and legible. The letter in the energy efficiency class arrow shall be positioned in the centre of the rectangular part of the arrow, with a border of 0,5 pt in 100 % black placed around the arrow and the letter of the energy efficiency class.

By way of derogation, if the visual advertisement, technical promotional material or paper-based distance selling is printed in monochrome, the arrow can be in monochrome in that visual advertisement, technical promotional material or paper-based distance selling.

*Figure 2*

**Coloured/monochrome left/right arrow, with range of energy efficiency classes indicated**



5. Telemarketing-based distance selling must specifically inform the customer of the energy efficiency class of the product and of the range of energy efficiency classes available on the label, and that the customer can access the full label and the product information sheet through a free access website, or by requesting a printed copy.
6. For all the situations mentioned in points 1 to 3 and 5, it must be possible for the customer to access the label and the product information sheet through a link to the product database website, or to request a printed copy.

**▼B***ANNEX VIII***Information to be provided in the case of distance selling on the internet**

1. The appropriate label made available by suppliers in accordance with point 1(g) Article 3 shall be shown on the display mechanism in proximity to the price of the product. The size shall be such that the label is clearly visible and legible and shall be proportionate to the size specified for the standard label in Annex III.

The label may be displayed using a nested display, in which case the image used for accessing the label shall comply with the specifications laid down in point 3 of this Annex. If nested display is applied, the label shall appear on the first mouse click, mouse roll-over or tactile screen expansion on the image.

2. The image used for accessing the label in the case of nested display, as indicated in Figure 3, shall:
  - (a) be an arrow in the colour corresponding to the energy efficiency class of the product on the label;
  - (b) indicate the energy efficiency class of the product on the arrow in 100 % white, Calibri Bold and in a font size equivalent to that of the price;
  - (c) have the range of available energy efficiency classes in 100 % black; and,
  - (d) have one of the following two formats, and its size shall be such that the arrow is clearly visible and legible. The letter in the energy efficiency class arrow shall be positioned in the centre of the rectangular part of the arrow, with a visible border in 100 % black placed around the arrow and the letter of the energy efficiency class:

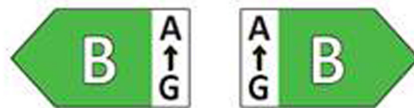
*Figure 3***Coloured left/right arrow, with range of energy efficiency classes indicated**

3. In the case of nested display, the sequence of display of the label shall be as follows:
  - (a) the image referred to in point 2 of this Annex shall be shown on the display mechanism in proximity to the price of the product;
  - (b) the image shall link to the label set out in Annex III;
  - (c) the label shall be displayed after a mouse click, mouse roll-over or tactile screen expansion on the image;
  - (d) the label shall be displayed by pop up, new tab, new page or inset screen display;
  - (e) for magnification of the label on tactile screens, the device conventions for tactile magnification shall apply;
  - (f) the label shall cease to be displayed by means of a close option or other standard-closing mechanism;
  - (g) the alternative text for the graphic, to be displayed upon failure to display the label, shall be the energy efficiency class of the product in a font size equivalent to that of the price.

**▼B**

4. The appropriate product information sheet made available by suppliers in accordance with point 1(h) of Article 3 shall be shown on the display mechanism in proximity to the price of the product. The size shall be such that the product information sheet is clearly visible and legible. The product information sheet may be displayed using a nested display or by referring to the product database, in which case the link used for accessing the product information sheet shall clearly and legibly indicate 'Product information sheet'. If nested display is used, the product information sheet shall appear on the first mouse click, mouse roll-over or tactile screen expansion on the link.

**▼ B***ANNEX IX***Verification procedure for market surveillance purposes****▼ M1**

The verification tolerances defined in this Annex relate only to the verification by Member State authorities of the declared values and shall not be used by the supplier as an allowed tolerance to establish the values in the technical documentation or in interpreting these values with a view to achieving compliance or to communicate better performance by any means. The values and classes published on the label or in the product information sheet shall not be more favourable for the supplier than the values declared in the technical documentation.

Where a model has been designed to be able to detect it is being tested (e.g. by recognising the test conditions or test cycle), and to react specifically by automatically altering its performance during the test with the objective of reaching a more favourable level for any of the parameters specified in this Regulation or included in the technical documentation or included in any of the documentation provided, the model and all equivalent models shall be considered not compliant.

► **M1** As part of verifying ◀ the compliance of a product model with the requirements laid down in this Delegated Regulation, the authorities of the Member States shall apply the following procedure:

1. The Member State authorities shall verify one single unit of the model for points 2(a) and 2(b) of this Annex.

The Member State authorities shall verify 10 units of the light source model for point 2(c) of this Annex. The verification tolerances are laid down in Table 9 of this Annex.

**▼ B**

2. The model shall be considered to comply with the applicable requirements if:
  - (a) the values given in the technical documentation pursuant to point 3 of Article 3 of Regulation (EU) 2017/1369 (declared values), and, where applicable, the values used to calculate these values, are not more favourable for the supplier than the corresponding values given in the test reports; and
  - (b) the values published on the label and in the product information sheet are not more favourable for the supplier than the declared values, and the indicated energy efficiency class is not more favourable for the supplier than the class determined by the declared values; and
  - (c) when the Member State authorities test the units of the model, the determined values comply with the respective verification tolerances as given in Table 9, where ‘determined value’ means the arithmetical mean over the tested units of the measured values for a given parameter or the arithmetical mean of parameter values calculated from other measured values.

**▼ M1**

3. If the results referred to in point 2(a), (b) or (c) are not achieved, the model and all equivalent models shall be considered not to comply with this Regulation.

**▼ B**

4. The Member State authorities shall provide all relevant information to the authorities of the other Member States and to the Commission without delay after a decision is taken on the non-compliance of the model in accordance with point 3 of this Annex.

The Member State authorities shall only apply the verification tolerances that are set out in Table 9 and shall use only the procedure described in this Annex. For the parameters in Table 9, no other tolerances, such as those set out in harmonised standards or in any other measurement method, shall be applied.

▼ **M1**

Table 9  
Verification tolerances

Parameter	Sample size	Verification tolerances
<b>Full-load on-mode power <math>P_{on}</math> [W]:</b>		
$P_{on} \leq 2W$	10	The determined value shall not exceed the declared value by more than 0,20 W.
$2W < P_{on} \leq 5W$	10	The determined value shall not exceed the declared value by more than 10 %.
$5W < P_{on} \leq 25W$	10	The determined value shall not exceed the declared value by more than 5 %.
$25W < P_{on} \leq 100W$	10	The determined value shall not exceed the declared value by more than 5 %.
$100W < P_{on}$	10	The determined value shall not exceed the declared value by more than 2,5 %.
<b>Displacement factor <math>[\theta-I]</math></b>	10	The determined value shall not be less than the declared value minus 0,1 units.
<b>Useful luminous flux <math>\Phi_{use}</math> [lm]</b>	10	The determined value shall not be less than the declared value minus 10 %.
<b>Standby power <math>P_{sb}</math> and networked standby power <math>P_{net}</math> [W]</b>	10	The determined value shall not exceed the declared value by more than 0,10 W.
<b>► <u>M2</u> CRI <math>[0-100]</math> and R9 ◀</b>	10	The determined value shall not be less than the declared value by more than 2,0 units.
<b>Flicker <math>[Pst LM]</math> and stroboscopic effect <math>[SVM]</math></b>	10	The determined value shall not exceed the declared value by more than 0,1 or by more than 10 % if the declared value is more than 1,0
<b>Colour consistency <math>[MacAdam ellips steps]</math></b>	10	The determined number of steps shall not exceed the declared number of steps. The centre of the MacAdam ellipse shall be the centre declared by the supplier with a tolerance of 0,005 units.
<b>Beam angle (degrees)</b>	10	The determined value shall not deviate from the declared value by more than 25 %.
<b>Total mains efficacy <math>\eta_{TM}</math> [lm/W]</b>	10	The determined value (quotient) shall not be less than the declared value minus 5 %.
<b>Lumen maintenance factor (for LED and OLED)</b>	10	The determined $X_{LMF}$ % of the sample shall not be less than $X_{LMF, MIN}$ % according to the text in Annex V of Commission Regulation (EU) 2019/2020 (1).

▼ **M1**

Parameter	Sample size	Verification tolerances
<b>Survival factor (for LED and OLED)</b>	10	At least 9 light sources of the test sample must be operational after completing the endurance test in Annex V of Regulation (EU) 2019/2020.
<b>Excitation purity [%]</b>	10	The determined value shall not be less than the declared value minus 5 %.
<b>Correlated colour temperature [K]</b>	10	The determined value shall not deviate from the declared value by more than 10 %.
<b>Peak luminous intensity [cd]</b>	10	The determined value shall not deviate from the declared value by more than 25 %.

<sup>(1)</sup> Commission Regulation (EU) 2019/2020 of 1 October 2019 laying down ecodesign requirements for light sources and separate control gears pursuant to Directive 2009/125/EC of the European Parliament and of the Council and repealing Commission Regulations (EC) No 244/2009, (EC) No 245/2009 and (EU) No 1194/2012 (see page 209 of this Official Journal).

For light sources with linear geometry which are scalable but of very long length, such as LED strips or strings, verification testing of market surveillance authorities shall consider a length of 50 cm, or, if the light source is not scalable there, the nearest value to 50 cm. The light source supplier shall indicate which control gear is suitable for this length.

When verifying if a product is a light source, market surveillance authorities shall compare the measured values for chromaticity coordinates (x and y), luminous flux, luminous flux density, and colour rendering index directly with the limit values set out in the definition for light source of Article 2 of this Regulation, without applying any tolerances. If any of the 10 units in the sample satisfies the conditions for being a light source, the product model shall be considered to be a light source.

Light sources that allow the end-user to control, manually or automatically, directly or remotely, the luminous intensity, colour, correlated colour temperature, spectrum, and/or beam angle of the emitted light shall be evaluated using the reference control setting.