

COMMISSION DIRECTIVE

of 10 December 1991

adapting to technical progress Council Directive 76/756/EEC relating to the installation of lighting and light-signalling devices on motor vehicles and their trailers

(91/663/EEC)

THE COMMISSION OF THE EUROPEAN COMMUNITIES,

Having regard to the Treaty establishing the European Economic Community, and in particular Article 100A thereof,

Having regard to Council Directive 70/156/EEC of 6 February 1970 relating to the type-approval of motor vehicles and their trailers ⁽¹⁾, as last amended by Directive 87/403/EEC of 25 June 1987 ⁽²⁾, and in particular Article 11 thereof,

Having regard to Council Directive 76/756/EEC of 27 July 1976 relating to the installation of lighting and light-signalling devices on motor vehicles and their trailers ⁽³⁾, as amended by Directives: 80/233/EEC of 21 November 1979 ⁽⁴⁾, 82/244/EEC of 17 March 1982 ⁽⁵⁾, 83/276/EEC of 26 May 1983 ⁽⁶⁾, 84/8/EEC of 14 December 1983 ⁽⁷⁾ and 89/278/EEC of 28 March 1989 ⁽⁸⁾,

Whereas for clarity it is now necessary to produce a consolidation of these Directives;

Whereas in the light of technical progress it is now possible to introduce further amendments, namely the colour of headlights will be required to be white only, side-marker lamps will be specified for certain vehicles and the requirement for lamps on movable components and other matters of detailed drafting can be clarified;

Whereas the measures provided for in this Directive are in accordance with the opinion of the Committee for the Adaptation to Technical Progress of Directives on the Removal of Technical Barriers to Trade in the Motor Vehicles Sector,

HAS ADOPTED THIS DIRECTIVE:

Article 1

Directive 76/756/EEC is amended as follows:

⁽¹⁾ OJ No L 42, 23. 2. 1970, p. 1.⁽²⁾ OJ No L 220, 8. 8. 1987, p. 44.⁽³⁾ OJ No L 262, 27. 9. 1976, p. 1.⁽⁴⁾ OJ No L 51, 25. 2. 1980, p. 8.⁽⁵⁾ OJ No L 109, 22. 4. 1982, p. 31.⁽⁶⁾ OJ No L 151, 9. 6. 1983, p. 47.⁽⁷⁾ OJ No L 9, 12. 1. 1984, p. 24.⁽⁸⁾ OJ No L 109, 20. 4. 1989, p. 38.

1. the Articles are replaced by the following Articles to this Directive;

2. the Annexes are replaced by the Annexes to this Directive.

Article 2

For the purposes of this Directive, 'vehicle' means any vehicle to which Council Directive 70/156/EEC applies.

Article 3

1. With effect from 1 January 1993, no Member State may:

— refuse, in respect of a type of vehicle, to grant EC type-approval, to issue the document referred to in the last indent of Article 10 (1) of Directive 70/156/EEC, or to grant national type-approval, or

— prohibit the entry into service of vehicles

on grounds relating to the installation of the lighting and light-signalling devices on this type of vehicle or on these vehicles if these devices are installed in accordance with the requirements of this Directive.

2. With effect from 1 October 1993, Member States:

— shall no longer issue the document referred to in the last indent of Article 10 (1) of Directive 70/156/EEC, and

— may refuse to grant national type-approval

in respect of a type of vehicle on which the installation of the lighting and light-signalling devices is not in accordance with the requirements of this Directive.

3. With effect from 1 October 1994, Member States may prohibit the first entry into service of vehicles on which the installation of these devices is not in accordance with the requirements of this Directive.

Article 4

A Member State which has granted EC type-approval shall take the necessary measures to ensure that it is informed of any modification to any parts or characteristics referred to in item 1.1 of Annex I. The competent authorities of that Member State shall determine whether further tests should be

carried out on the modified vehicle type and a fresh report drawn up. Where such tests reveal failure to comply with the requirements of this Directive, the modification shall not be approved.

Article 5

Any amendments necessary in order to adapt the content of the Annexes to this Directive to take account of technical progress shall be adopted in accordance with the procedure laid down in Article 13 of Directive 70/156/EEC.

Article 6

1. Member States shall bring into force the legislative, regulatory and administrative provisions necessary in order to comply with this Directive before 1 January 1993 and shall forthwith inform the Commission thereof.

2. When the Member States adopt these provisions they shall make a reference to this Directive in their official

publication. The form of this reference shall be determined by the Member States.

3. Member States shall ensure that the terms of the main provisions of national law which they adopt in the field covered by this Directive are communicated to the Commission.

Article 7

This Directive is addressed to the Member States.

Done at Brussels, 10 December 1991.

For the Commission
Martin BANGEMANN
Vice-President

ANNEX I

INSTALLATION OF LIGHTING AND LIGHT-SIGNALLING DEVICES

1. DEFINITIONS

For the purposes of this Directive:

1.1. 'Vehicle type with regard to the installation of lighting and light-signalling devices'

means vehicles which do not differ in the essential respects mentioned in items 1.1.1 to 1.1.4.

The following are likewise considered not to be 'vehicles of a different type': vehicles which differ within the meaning of items 1.1.1 to 1.1.4, but not in such a way as to entail a change in the kind, number, positioning and geometric visibility of the lamps and the inclination of the dipped beam prescribed for the vehicle type in question, and vehicles on which optional lamps are fitted or are absent;

1.1.1. the dimensions and the external shape of the vehicle;

1.1.2. the number and positioning of the devices;

1.1.3. the headlamp-levelling system;

1.1.4. the suspension system.

1.2. 'Transverse plane'

means a vertical plane perpendicular to the median longitudinal plane of the vehicle.

1.3. 'Unladen vehicle'

means the vehicle in running order, as defined in item 2.6 of Annex I, model information document, to Directive 70/156/EEC, but without driver.

1.4. 'Laden vehicle'

means the vehicle loaded to its technically permissible maximum mass, as stated by the manufacturer, who shall also fix the distribution of this mass between the axles in accordance with the method described in Appendix 1.

1.5. 'Device'

means an element or an assembly of elements used to perform one or more functions.

1.6. 'Light source with regard to filament lamps'

means the filament itself. (Where a lamp has several filaments, each one shall constitute a light source).

1.7. 'Lamp'

means a device designed to illuminate the road or to emit a light signal. Rear registration plate lamps and retro reflectors are likewise regarded as lamps.

1.7.1. 'Equivalent lamps'

means lamps having the same function and authorized in the country in which the vehicle is registered; such lamps may have different characteristics from those installed on the vehicle when it is approved on condition that they satisfy the requirements of this Annex.

1.7.2. 'Single-function lamp'

means a part of a device which performs a single lighting or light-signalling function.

1.7.3. 'Independent lamps' ⁽¹⁾

means devices having separate illuminating surfaces, separate light sources and separate lamp bodies.

⁽¹⁾ In the case of lighting devices for the rear number plate and the direction indicators (category 5), replace 'illuminating surface' by 'light-emitting surface' in the absence of an illuminating surface.

- 1.7.4. *'Grouped lamps'* ⁽¹⁾
means devices having separate illuminating surfaces and separate light sources, but a common lamp body.
- 1.7.5. *'Combined lamps'* ⁽¹⁾
means devices having separate illuminating surfaces, but a common light source and a common lamp body.
- 1.7.6. *'Reciprocally incorporated lamps'* ⁽¹⁾
Means devices having separate light sources or a single light source operating under different conditions (e.g. optical, mechanical or electrical differences), totally or partially common illuminating surfaces and a common lamp body.
- 1.7.7. *'Concealable lamp'*
means a lamp capable of being partly or completely hidden when not in use. This result may be achieved by means of a movable cover, by displacement of the lamp or by any other suitable means. The term 'retractable' is used more particularly to describe a concealable lamp, the displacement of which enables it to be inserted within the bodywork.
- 1.7.8. *'Main-beam headlamp'*
means the lamp used to illuminate the road over a long distance ahead of the vehicle.
- 1.7.9. *'Dipped-beam headlamp'*
means the lamp used to illuminate the road ahead of the vehicle without causing undue dazzle or discomfort to oncoming drivers and other road-users.
- 1.7.10. *'Front fog lamp'*
means the lamp used to improve the illumination of the road in case of fog, snowfall, rainstorms or dust clouds.
- 1.7.11. *'Reversing lamp'*
means the lamp used to illuminate the road to the rear of the vehicle and to warn other road-users that the vehicle is reversing or about to reverse.
- 1.7.12. *'Direction indicator lamp'*
means the lamp used to indicate to other road-users that the driver intends to change direction to the right or to the left.
- 1.7.13. *'Hazard warning signal'*
means the simultaneous operation of all of a vehicle's direction indicator lamps to draw attention to the fact that the vehicle temporarily constitutes a special danger to other road-users.
- 1.7.14. *'Stop lamp'*
means the lamp used to indicate to other road-users to the rear of the vehicle that the latter's driver is applying the service brake.
- 1.7.15. *'Rear registration plate lamp'*
means the device used to illuminate the space intended to accommodate the rear registration plate; it may consist of different optical elements.
- 1.7.16. *'Front position lamp'*
means the lamp used to indicate the presence and the width of the vehicle when viewed from the front.
- 1.7.17. *'Rear position lamp'*
means the lamp used to indicate the presence and the width of the vehicle when viewed from the rear.
- 1.7.18. *'Rear fog lamp'*
means the lamp used to render the vehicle more readily visible from the rear in dense fog.

⁽¹⁾ In the case of lighting devices for the rear number plate and the direction indicators (category 5), replace 'illuminating surface' by 'light-emitting surface' in the absence of an illuminating surface.

- 1.7.19. **'Parking lamp'**
means the lamp used to draw attention to the presence of a stationary vehicle in a built-up area. In such circumstances it replaces the front and rear position lamps.
- 1.7.20. **'End-outline marker lamp'**
means the lamp fitted to the extreme outer edge as close as possible to the top of the vehicle and intended clearly to indicate the vehicle's overall width. This lamp is intended, for certain vehicles and trailers, to complement the vehicle's front and rear position lamps by drawing particular attention to its bulk.
- 1.7.21. **'Side-marker lamp'**
means a lamp used to indicate the presence of the vehicle when viewed from the side.
- 1.7.22. **'Retro reflector'**
means a device used to indicate the presence of a vehicle by the reflection of light emanating from a light source not connected to the vehicle, the observer being situated near the source.
For the purposes of this Directive the following are not considered as retro reflectors:
- retro-reflecting number plates,
 - the retro-reflecting signals mentioned in the ADR (European Agreement concerning the international carriage of dangerous goods by road),
 - other retro-reflecting plates and signals which must be used to comply with a Member State's specifications for use as regards certain categories of vehicles or certain modes of operation.
- 1.8. **'Light-emitting surface'**
means all or part of the exterior surface of the translucent material which helps to confer on the light its particular photometric and colorimetric properties. When only part of the exterior surface emits light, the light-emitting surface shall, in case of doubt, be specified by the competent authority after consultation with the vehicle and/or component manufacturer.
- 1.9. **Illuminating surfaces**
- 1.9.1. **'Illuminating surface of a lighting device'** (Item 1.7.8 to 1.7.11)
means the orthogonal projection of the full aperture of the reflector in a transverse plane. If the lighting device has no reflector, the definition of item 1.9.2 shall be applied. If the light-emitting surface of the lamp extends over a part only of the full aperture of the reflector, then the projection of that part only is taken into account.
In the case of a dipped-beam headlamp, the illuminating surface is limited by the apparent trace of the cut-off on to the lens. If the reflector and lens are adjustable relative to one another, the mean adjustment should be used.
- 1.9.2. **'Illuminating surface of a signalling lamp other than a retro reflector'** (Items 1.7.12 to 1.7.21)
means the orthogonal projection of the lamp in a plane perpendicular to its axis of reference and in contact with the exterior light-emitting surface of the lamp, this projection being bounded by the edges of the screens situated in this plane, each allowing only 98 % of the total luminous intensity of the light to persist in the direction of the axis of reference.
To determine the lower, upper and lateral limits of the illuminating surface, only screens with horizontal or vertical edges shall be used.
- 1.9.3. **'Illuminating surface of a retro reflector'** (Items 1.7.22)
means the illuminating surface of a retro reflector in a plane perpendicular to the axis of reference and bounded by planes touching the outer edges of the light projection surface of the retro reflector and parallel to this axis. To determine the lower, upper and lateral limits of the illuminating surface, only vertical and horizontal planes shall be used.
- 1.10. **'Apparent surface'**
for a defined direction of observation, means the orthogonal projection of the light-emitting surface in a plane perpendicular to the direction of observation (see drawing in Appendix 2) and tangential to the most exterior point of the lens.

1.11. 'Axis of reference'

means the characteristic axis of the light signal, determined by the manufacturer for use as the direction of reference ($H = 0^\circ$, $V = 0^\circ$) for angles of field for photometric measurements and when fitting the lamp on the vehicle.

1.12. 'Centre of reference'

means the intersection of the axis of reference with the light-emitting surface. This centre of reference is to be specified by the manufacturer of the lamp.

1.13. 'Angles of geometric visibility'

means the angles which determine the field of the minimum solid angle in which the apparent surface of the lamp must be visible. That field of the solid angle is determined by the segments of the sphere of which the centre coincides with the centre of reference of the lamp and the equator is parallel with the ground. These segments are determined in relation to the axis of reference. The horizontal angles β correspond to the longitude and the vertical angles α to the latitude.

There must be no obstacle on the inside of the angles of geometric visibility to the propagation of light from any part of the apparent surface of the lamp observed from infinity.

If measurements are taken closer to the lamp, there must be a parallel shift in the direction of observation to achieve the same accuracy.

No account shall be taken of obstacles on the inside of the angles of geometric visibility, if they were already present when the lamp was type-approved.

If, when the lamp is installed, any part of the apparent surface of the lamp is hidden by any further parts of the vehicle, proof shall be furnished that the part of the lamp not hidden by obstacles still conforms to the photometric values prescribed for the approval of the device as an optical unit (see figure below).

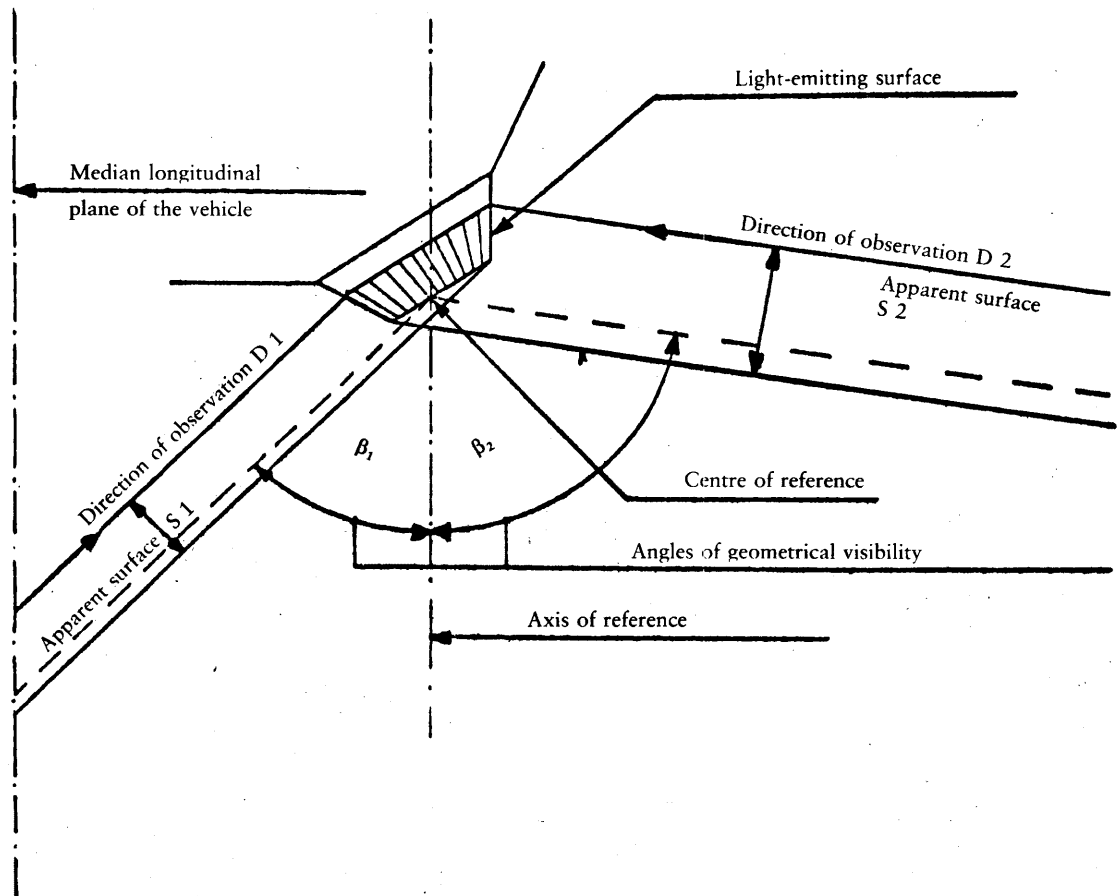

- 1.14. **'Extreme outer edge'**
on either side of the vehicle means the plane parallel to the median longitudinal plane of the vehicle and touching its lateral outer edge, disregarding the projection:
- 1.14.1. of tyres near their point of contact with the ground and connections for tyre pressure gauges;
 - 1.14.2. of anti-skid devices which may be mounted on the wheels;
 - 1.14.3. of rear-view mirrors;
 - 1.14.4. of side direction indicator lamps, end-outline marker lamps, front and rear position lamps, parking lamps, retro reflectors and side-marker lamps;
 - 1.14.5. of customs seals affixed to the vehicle and devices for securing and protecting such seals.
- 1.15. **'Overall width'**
means the distance between the two vertical planes defined in item 1.14.
- 1.16. **A 'single lamp'**
means a device or part of a device, having one function and one illuminating surface and one or more light sources. For the purpose of installation on a vehicle, a 'single lamp' also means any assembly of two independent or grouped lamps, whether identical or not, having the same function, if they are installed such that the projections of the illuminating surfaces of the lamps on a given transverse plane occupy not less than 60 % of the smallest rectangle circumscribing the projections of the said illuminating surfaces.

In such a case, each of these lamps shall, where approval is required, be approved as a type 'D' lamp. This possible combination does not apply to main-beam headlamps, dipped-beam headlamps and front fog lamps.
- 1.17. **'Two lamps or an even number of lamps'**
means a single light-emitting surface in the shape of a band if placed symmetrically in relation to the median longitudinal plane of the vehicle and extending on both sides to within not less than 400 mm of the extreme outer edge of the vehicle, and being not less than 800 mm long. The illumination of such a surface shall be provided by not less than two light sources placed as close as possible to its ends. The light-emitting surface may be constituted by a number of juxtaposed elements on condition that the projections of the several individual light-emitting surfaces on the same transverse plane occupy not less than 60 % of the area of the smallest rectangle circumscribing the projections of those individual light-emitting surfaces.
- 1.18. **'Distance between two lamps'**
which face in the same direction means the shortest distance between the orthogonal projections in a plane perpendicular to the axes of reference of the outlines of the two illuminating surfaces as defined according to the case mentioned in item 1.9. The distance between two lamps may, however, be measured without determining the outlines of the illuminating surfaces exactly, where the distance is clearly in excess of the minimum requirements of the Directive.
- 1.19. **'Optional lamp'**
means a lamp the presence of which is left to the discretion of the vehicle manufacturer.
- 1.20. **'Operational tell-tale'**
means a light or auditory device showing whether a device that has been actuated is operating correctly or not.
- 1.21. **'Circuit-closed tell-tale'**
means a light showing that a device has been switched on but not showing whether it is operating correctly or not.
- 1.22. **'Ground'**
means the surface on which the vehicle stands, which should be substantially horizontal.
- 1.23. **'Movable components'**
of the vehicle means those body panels or other vehicle parts, the position of which can be changed by tilting, rotating or sliding without the use of tools. They do not include tiltable driver cabs.

- 1.24. **'Normal position of use of a movable component'**
means the position(s) of a movable component specified by the vehicle manufacturer for the normal condition of use and the park condition of the vehicle.
- 1.25. **'Normal condition of use of a vehicle'**
means:
- 1.25.1. for a motor vehicle, when the vehicle is ready to move with its propulsion engine running and its movable components in the normal position(s) as defined in item 1.24;
- 1.25.2. and for a trailer, when the trailer is connected to a drawing vehicle in the condition as described in item 1.25.1 and its movable components are in the normal position(s) as defined in item 1.24.
- 1.26. **'Park condition of a vehicle'**
means:
- 1.26.1. for a motor vehicle, when the vehicle is at a standstill and its propulsion engine is not running and its movable components are in the normal position(s) as defined in item 1.24;
- 1.26.2. and for a trailer, when the trailer is connected to a drawing vehicle in the condition as described in item 1.26.1 and its movable components are in the normal position(s) as defined in item 1.24.
2. **APPLICATION FOR EC TYPE-APPROVAL**
- 2.1. The application for EC approval of a vehicle type with regard to the installation of its lighting and light-signalling devices shall be submitted by the vehicle manufacturer or his representative.
- 2.2. It shall be accompanied by the following documents in triplicate, and by the following particulars:
- 2.2.1. a description of the vehicle type in accordance with the points listed in 1.1, together with the restrictions on loading, particularly the maximum permissible load in the boot;
- 2.2.2. a list of devices prescribed by the manufacturer for the lighting and light-signalling assembly. The list may include several types of device for each operation. Each type must be duly identified (component type-approval mark, name of manufacturer, etc.);
- 2.2.3. layout drawing of the lighting and light-signalling equipment as a whole, showing the position of the various lamps on the vehicle;
- 2.2.4. if necessary, in order to verify conformity to the requirements of the present Directive, layout drawing(s) for each individual lamp showing the illuminating surface as defined in items 1.9.1, 1.9.2 and 1.9.3, the light-emitting surface as defined in item 1.8, the axis of reference as defined in item 1.11 and the centre of reference as defined in item 1.12. This information is not necessary in the case of the rear registration plate lamp (item 1.7.15).
- 2.3. An unladen vehicle fitted with lighting and light-signalling equipment as described in item 2.2.2 and representative of the vehicle type to be approved, must be submitted to the technical authority conducting approval tests.
- 2.4. The document provided for in Annex II shall be attached to the type-approval document.
3. **GENERAL SPECIFICATIONS**
- 3.1. Without prejudice to the provisions of this Annex, solely the installation of the lighting and light-signalling devices defined in items 1.7.8 to 1.7.22 shall be permitted. The installation of any other lighting or light-signalling device is consequently prohibited.
- 3.2. The lighting and light-signalling devices must be so fitted that under normal conditions of use as defined in items 1.25, 1.25.1 and 1.25.2, and notwithstanding any vibration to which they may be subjected, they retain the characteristics laid down in this Annex and enable the vehicle to comply with the requirements of this Annex. In particular, it shall not be possible for the adjustment of the lamps to be inadvertently disturbed.
- 3.3. The illuminating lamps described in items 1.7.8, 1.7.9 and 1.7.10 must be so fitted that a correct setting of their alignment can easily be performed.

- 3.4. For all light-signalling devices, including those mounted on the side panels, the reference axis of the lamp when fitted to the vehicle must be parallel to the bearing plane of the vehicle on the road; in addition it must be perpendicular to the median longitudinal plane of the vehicle in the case of side retro reflectors and of side-marker lamps and parallel to that plane in the case of all other signalling devices. In each direction a tolerance of $\pm 3^\circ$ shall be allowed. In addition, any specific instructions as regards fitting laid down by the manufacturer must be complied with.
- 3.5. In the absence of specific requirements, the height and alignment of the lamps shall be checked with the unladen vehicle placed on a flat, horizontal surface under the conditions defined in items 1.25, 1.25.1 and 1.25.2.
- 3.6. In the absence of specific requirements, lamps constituting a pair shall:
- 3.6.1. be fitted to the vehicle symmetrically in relation to the median longitudinal plane (this estimate to be based on the exterior geometrical form of the lamp and not on the edge of its illuminating surface referred to in items 1.9.1, 1.9.2 and 1.9.3);
- 3.6.2. be symmetrical to one another in relation to the median longitudinal plane; this requirement is not valid with regard to the interior structure of the lamp;
- 3.6.3. satisfy the same colorimetric characteristics;
- 3.6.4. have substantially identical photometric characteristics.
- 3.7. On vehicles whose external shape is asymmetrical, the above requirements shall be satisfied as far as possible.
- 3.8. Lamps having different functions may be independent or be grouped, combined or reciprocally incorporated in one device, provided that each such lamp complies with the requirements applicable to it.
- 3.9. The maximum height above ground shall be measured from the highest point and the minimum height from the lowest point of the illuminating surface.
- In the case of dipped headlamps, the minimum height in relation to the ground is measured from the lowest edge of the reflector.
- 3.9.1. The position, as regards width, shall be determined from the edge of the illuminating surface which is the furthest from the median longitudinal plane of the vehicle when referred to the overall width, and from the inner edges of the illuminating surfaces when referred to the distance between the lamps.
- 3.10. In the absence of specific requirements no lamps other than direction indicator lamps and the hazard warning signal may emit a flashing light.
- 3.11. No red light which could give rise to confusion shall be emitted from a lamp as defined in item 1.7 in a forward direction and no white light which could give rise to confusion, other than from the reversing lamp, shall be emitted from a lamp as defined in item 1.7 in a rearward direction. No account shall be taken of lighting devices fitted in the interior of the vehicle. In case of doubt, this requirement shall be verified as follows:
- 3.11.1. for the visibility of red light towards the front: there must be no direct visibility of the light-emitting surface of a red lamp if viewed by an observer moving within Zone 1 in a transverse plane situated 25 m in front of the vehicle (see Appendix 3, Figure 1);
- 3.11.2. for the visibility of white light towards the rear: there must be no direct visibility of the light-emitting surface of a white lamp if viewed by an observer moving within Zone 2 in a transverse plane situated 25 m behind the vehicle (see Appendix 3, Figure 2).
- 3.11.3. Zones 1 and 2, as seen by the observer, are limited in their respective planes as follows:
- 3.11.3.1. as regards height, by two horizontal planes which are 1 and 2.2 m respectively above the ground;
- 3.11.3.2. as regards width, by two vertical planes which make an angle of 15° towards the front and rear respectively, and outside the vehicle by reference to the median plane of the vehicle, passing through the point (or points) of contacts of vertical planes which are parallel to the median longitudinal plane of the vehicle, and limiting the overall width of the vehicle.
- If there are several points of contact, the one which is furthest forward shall correspond to the front plane and the one furthest rearward shall correspond to the rear plane.
- 3.12. The electrical connections must be such that the front and rear position lamps, the end-outline marker lamps, where fitted, the side-marker lamps, where fitted, and the rear registration plate lamp can only be switched on and off simultaneously.

This requirement shall not apply when using front and rear position lamps, as well as side-marker lamps combined or reciprocally incorporated with said lamps, as parking lamps.

- 3.13. The electrical connections must be such that the main-beam and dipped-beam headlamps and the front fog lamps cannot be switched on unless the lamps referred to in item 3.12 are also switched on. This requirement shall not apply, however, to main-beam or dipped-beam headlamps when their luminous warnings consist of the intermittent lighting up at short intervals of the main-beam headlamp or the intermittent lighting up at short intervals of the dipped-beam headlamp or the alternate lighting up at short intervals of the main-beam and dipped-beam headlamps.
- 3.14. The colours of the light emitted by the lamps are the following:
- | | |
|--|--|
| — main-beam headlamp: | white |
| — dipped-beam headlamp: | white |
| — front fog lamp: | white or yellow |
| — reversing lamp: | white |
| — direction indicator lamp: | amber |
| — hazard warning signal: | amber |
| — stop lamp: | red |
| — rear registration plate lamp: | white |
| — front position lamp: | white |
| — rear position lamp: | red |
| — rear fog lamp: | red |
| — parking lamp: | white in front, red at the rear, amber if incorporated in the side direction indicator lamps or in the side-marker lamps |
| — side-marker lamp: | amber; however, it may be red if the rearmost side-marker lamp is grouped or combined or reciprocally incorporated with the rear position lamp, the rear end-outline marker lamp, the rear fog lamp, the stop lamp or is grouped or has part of the light-emitting surface in common with the rear retro reflector |
| — end-outline marker lamp: | white in front, red at the rear |
| — rear retro reflector, non-triangular: | red |
| — rear retro reflector, triangular: | red |
| — front retro reflector, non-triangular ⁽¹⁾ : | identical to incident light |
| — side retro reflector, non-triangular | amber; however, it may be red if the rearmost side retro reflector is grouped or has part of the light-emitting surface in common with the rear position lamp, the rear end-outline marker lamp, the rear fog lamp, the stop lamp or the red rearmost side-marker lamp. |
- 3.15. The function of the circuit-closed tell-tales may be fulfilled by operational tell-tales.
- 3.16. **Concealable lamps**
- 3.16.1. The concealment of lamps shall be prohibited, with the exception of the main-beam headlamp, the dipped-beam headlamp and the front fog lamp, which may be concealed when not in use.
- 3.16.2. In the event of any failure affecting the operations of the concealment device(s) the lamps shall remain in the position of use, if already in use, or shall be capable of being moved into the position of use without the aid of tools.
- 3.16.3. It must be possible to move the lamps into the position of use and to switch them on by means of a single control, without excluding the possibility of moving them into the position of use without switching them on.
- However, in the case of grouped main-beam and dipped-beam headlamps, the control referred to above is required only to activate the dipped-beam headlamps.

⁽¹⁾ Also known as 'white' or 'colourless' reflector.

- 3.16.4. It must not be possible deliberately, from the driver's seat, to stop the movement of switched-on lamps before they reach the position of use. If there is a danger of dazzling other road users by the movement of the lamps, they may light up only when they have reached their position of use.
- 3.16.5. At temperatures of -30 to $+50$ °C a lamp must be capable of reaching the position of use within three seconds of initial operation of the control.
- 3.17. **Number of lamps**
- The number of lamps mounted on the vehicle shall be equal to the number(s) specified in subitem 2 of items 4.1 to 4.18.
- 3.18. Except as provided by items 3.19, 3.20 and 3.22, lamps may be installed on movable components.
- 3.19. Rear position lamps, rear direction indicator lamps and rear retro reflectors, triangular as well as non-triangular, must not be installed on movable components. Should the above functions be obtained by an assembly of two lamps marked 'D' (see item 1.16), only one of these lamps need be installed on the non-movable part of the vehicle.
- 3.20. There must not be any movable component, with or without a light signalling device installed on it, which in any fixed position hides more than 50 % of the apparent surface of front and rear position lamps, front and rear direction indicator lamps and retro reflectors when viewed in a direction parallel to the longitudinal axis of the vehicle.
- If this is not practicable:
- 3.20.1. a remark in item 16 of the document in Annex II shall inform other administrations that more than 50 % of the apparent surface can be hidden by the movable components;
- 3.20.2. in the case of item 3.20.1 a notice in the vehicle shall inform the user that in certain position(s) of the movable components other road users shall be warned of the presence of the vehicle on the road; for example by means of a warning triangle or other devices according to national requirements for use on the road.
- 3.21. When the movable components are in a position other than a 'normal position' as defined in item 1.24 the devices installed on them shall not cause undue discomfort to road users.
- 3.22. When a lamp is installed on a movable component and the movable component is in the normal position(s) of use (see item 1.24), the lamp must always return to the position(s) specified by the manufacturer in accordance with this Annex. In the case of dipped-beam headlamps and front fog lamps, this requirement shall be considered satisfied if, when the movable components are moved and returned to the normal position 10 times, no value of the angle inclination of these lamps, relative to its support, measured after each operation of the movable component, differs by more than 0,15 % from the average of the 10 measured values.
- 3.23. Lamps may be grouped, combined or reciprocally incorporated with one another provided that all requirements regarding colour, position, alignment, geometric visibility, electrical connections and 'other requirements', if any, for each lamp, are fulfilled.
- 3.24. With the exception of retro reflectors, a lamp even bearing an approval mark shall be deemed not to be present when it cannot be made to operate by the sole installation of a filament lamp.
4. **INDIVIDUAL SPECIFICATIONS**
- 4.1. **Main-beam headlamps**
- 4.1.1. *Presence*
- Mandatory on motor vehicles.
- Prohibited on trailers.

- 4.1.2. *Number*
Two or four.
Where a vehicle is fitted with four concealable main-beam headlamps the installation of two additional main-beam headlamps shall only be authorized for the purpose of light signalling (as defined in item 3.13) in daylight.
- 4.1.3. *Arrangement*
No individual specifications.
- 4.1.4. *Position*
- 4.1.4.1. *Width:*
the outer edges of the illuminating surface must in no case be closer to the extreme outer edge of the vehicle than the outer edges of the illuminating surface of the dipped-beam headlamps.
- 4.1.4.2. *Height:*
no individual specifications.
- 4.1.4.3. *Length:*
at the front of the vehicle and fitted in such a way that the light emitted does not cause discomfort to the driver either directly or indirectly through the rear-view mirrors and/or other reflecting surfaces of the vehicles.
- 4.1.5. *Geometric visibility*
The visibility of the illuminating surface, including its visibility in areas which do not appear to be illuminated in the direction of observation considered, must be ensured within a divergent space defined by generating lines based on the perimeter of the illuminating surface and forming an angle of not less than 5° with the axis of reference of the headlamp. The origin of the angles of geometric visibility is the perimeter of the projection of the illuminating surface on a transverse plane tangent to the foremost part of the lens of the headlamp.
- 4.1.6. *Alignment*
Towards the front.
Apart from the devices necessary to maintain correct adjustment, and when there are two pairs of headlamps, one pair, consisting of headlamps functioning as main-beam headlamps only may swivel, according to the angle of lock of the steering, about an axis very near the vertical.
- 4.1.7. *Electrical connections*
- 4.1.7.1. The main-beam headlamps may be switched on either simultaneously or in pairs. For changing over from the dipped to the main beam at least one pair of main beams must be switched on. For changing over from the main to the dipped beam all main-beam headlamps must be switched off simultaneously.
- 4.1.7.2. The dipped beams may remain switched on at the same time as the main beams.
- 4.1.7.3. Where four concealable main-beam headlamps are fitted their raised position must prevent the simultaneous operation of any additional main-beam headlamps fitted, if these are intended to provide light signals (as defined in item 3.13) in daylight.
- 4.1.8. *Circuit-closed tell-tale*
Mandatory.
- 4.1.9. *Other requirements*
- 4.1.9.1. The aggregate maximum intensity of the headlamp beams which can be switched on simultaneously must not exceed 225 000 cd.
- 4.1.9.2. This maximum intensity shall be obtained by adding together the individual maximum intensities measured at the time of component type-approval and shown on the relevant approval certificates.
- 4.2. *Dipped-beam headlamps*
- 4.2.1. *Presence*
Mandatory on motor vehicles.
Prohibited on trailers.
- 4.2.2. *Number*
Two.

4.2.3. *Arrangement*

No individual specifications.

4.2.4. *Position*4.2.4.1. *Width:*

the edge of the illuminating surface which is farthest from the vehicle's median longitudinal plane must be not more than 400 mm from the extreme outer edge of the vehicle.

The inner edges of the illuminating surfaces must not be less than 600 mm apart.

This distance may be reduced to 400 mm where the overall width of the vehicle is less than 1 300 mm.

4.2.4.2. *Height:*

above the ground: not less than 500 mm and not more than 1 200 mm.

4.2.4.3. *Length:*

at the front of the vehicle; this requirement shall be regarded as satisfied if the light emitted does not cause discomfort to the driver either directly, or indirectly through the rear-view mirrors and/or other reflecting surfaces of the vehicle.

4.2.5. *Geometric visibility*

Defined by angles α and β as specified in item 1.13.

α = 15° upwards and 10° downwards,

β = 45° outwards and 10° inwards.

Since the photometric values required for dipped-beam headlamps do not cover the full geometric field of vision, a minimum value of 1 cd in the space remaining is required for type-approval purposes. The presence of panels or other items of equipment near the light must not give rise to secondary effects causing discomfort to other road users.

4.2.6. *Alignment*

4.2.6.1. After adjustment of the initial inclination, the vertical inclination of the dipped beam, expressed in percent, shall be measured in static conditions under all the loading conditions defined in Appendix 1.

The initial downward inclination of the cut-off of the dipped beam to be set in the unladen vehicle state with one person in the driver's seat shall be specified to within 0,1% by the vehicle manufacturer and indicated in a clearly legible and indelible manner on each vehicle close to either headlamps or the manufacturer's plate by the symbol shown in Appendix 6.

The value of this indicated downward inclination is defined in item 4.2.6.1.1.

4.2.6.1.1. Depending on the mounting height in meters (h) of the lower edge of the illuminating surface of the dipped-beam headlamp, measured on the unladen vehicle, the vertical inclination of the cut-off of the dipped beam shall, under all the static conditions of Appendix 1, remain between the following limits and the initial aiming shall have the following values:

$h < 0,80$

limits:	between -0,5% and -2,5%
initial aiming:	between -1,0% and -1,5%;

$0,80 \leq h \leq 0,90$

limits:	between -0,5% and -2,5%
initial aiming:	between -1,0% and -1,5%,

or, at the discretion of the vehicle manufacturer

limits:	between -1,0% and -3,0%
initial aiming:	between -1,5% and -2,0%;

the application for EC vehicle type-approval shall, in this case, contain information as to which of the two alternatives is to be used;

$h > 0,90$

limits:	between -1,0% and -3,0%
initial aiming:	between -1,5% and -2,0%.

The above limits and the initial aiming values are summarized in the diagram below.

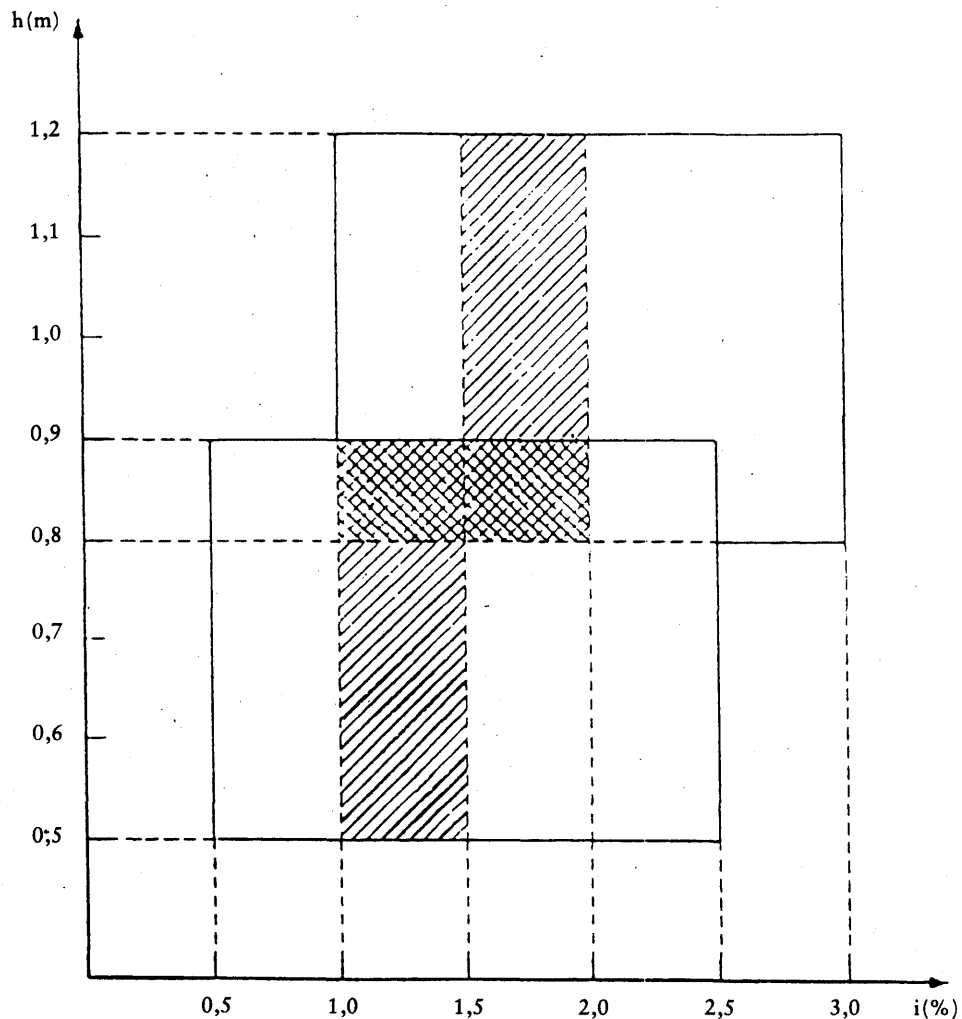

4.2.6.2. The preceding condition may be satisfied by means of a device acting on the relative position of the headlamp and the vehicle. In the case of this device failing the beam must not return to a position less inclined downwards than its position at the time of failure of the device.

4.2.6.2.1. The device mentioned in item 4.2.6.2 must be automatic.

4.2.6.2.2. Devices which are adjusted manually, either continuously or non-continuously, shall nevertheless be permitted, provided they have a stop position at which the lamps can be returned to the initial inclination defined in item 4.2.6.1 by means of the usual adjusting screws. These manually adjustable devices must be operable from the driving seat. Continually adjustable devices must have reference marks indicating the loading conditions that require adjustment of the dipped beam.

The number of positions on devices which are not continuously adjustable must be such as to ensure compliance with the range of values specified in item 4.2.6.1.1 in all the loading conditions defined in Appendix 1.

For these devices also, the loading conditions of Appendix 1 that require adjustment of the dipped beam shall be clearly marked near the control of the device (see Appendix 7).

4.2.6.2.3. The measurement of the variation of dipped-beam inclination as a function of load must be carried out in accordance with the test procedure set out in Appendix 5.

4.2.7. *Electrical connections*

The control for changing over to the dipped beam must switch off all main-beam headlamps simultaneously.

The dipped beams may remain switched on at the same time as the main beams.

4.2.8. *Circuit-closed tell-tale*

Optional.

- 4.2.9. *Other requirements*
The requirements of item 3.6.2 shall not apply to dipped-beam headlamps.
Dipped-beam headlamps shall not swivel according to the angle of lock of the steering.
- 4.3. **Front fog lamps**
- 4.3.1. *Presence*
Optional on motor vehicles.
Prohibited on trailers.
- 4.3.2. *Number*
Two.
- 4.3.3. *Arrangement*
No individual specifications.
- 4.3.4. *Position*
- 4.3.4.1. *Width:*
the point on the illuminating surface which is farthest from the vehicle's median longitudinal plane must be not more than 400 mm from the extreme outer edge of the vehicle.
- 4.3.4.2. *Height:*
not less than 250 mm above the ground.
No point on the illuminating surface must be higher than the highest point on the illuminating surface of the dipped-beam headlamp.
- 4.3.4.3. *Length:*
at the front of the vehicle: this requirement shall be considered to be satisfied if the light emitted does not cause discomfort to the driver either directly or indirectly through the rear-view mirrors and/or other reflecting surfaces of the vehicle.
- 4.3.5. *Geometric visibility*
Defined by angles α and β as specified in item 1.13.
 $\alpha = 5^\circ$ upwards and downwards,
 $\beta = 45^\circ$ outwards and 10° inwards.
- 4.3.6. *Alignment*
The alignment of the front fog lamps must not vary according to the angle of lock of the steering.
They must be directed forwards without causing undue dazzle or discomfort to oncoming drivers and other road users.
- 4.3.7. *Electrical connections*
It must be possible to switch the front fog lamps on and off independently of the main-beam headlamps, the dipped-beam headlamps or any combination of main- and dipped-beam headlamps.
- 4.3.8. *Circuit-closed tell-tale*
Optional.
- 4.4. **Reversing lamps**
- 4.4.1. *Presence*
Mandatory on motor vehicles.
Optional on trailers.
- 4.4.2. *Number*
One or two.
- 4.4.3. *Arrangement*
No individual specifications.
- 4.4.4. *Position*
- 4.4.4.1. *Width:*
no individual specifications.

- 4.4.4.2. **Height:**
not less than 250 mm and not more than 1 200 mm above the ground.
- 4.4.4.3. **Length:**
at the back of the vehicle.
- 4.4.5. **Geometric visibility**
Defined by angles α and β as specified in item 1.13.
 $\alpha = 15^\circ$ upwards and 5° downwards,
 $\beta = 45^\circ$ to right and left if there is only one lamp,
 $\beta = 45^\circ$ outwards and 30° inwards if there are two.
- 4.4.6. **Alignment**
Rearwards.
- 4.4.7. **Electrical connections**
Reversing lamps may only light up if the reverse gear is engaged and if the device which controls the starting or stopping of the engine is in such a position that operation of the engine is possible.
They must not light up or remain lit up if either of the above conditions is not satisfied.
- 4.4.8. **Circuit-closed tell-tale**
Optional.
- 4.5. **Direction indicator lamps**
- 4.5.1. **Presence** (see Appendix 4)
Mandatory. Types of direction indicator lamps fall into categories (1, 1 a, 1 b, 2 a, 2 b and 5), the assembly of which on one vehicle constitutes an arrangement ('A' and 'B').
Arrangement 'A' shall apply to all motor vehicles.
Arrangement 'B' shall apply to trailers only.
- 4.5.2. **Number**
The number of devices shall be such that they can emit signals which correspond to one of the arrangements referred to in item 4.5.3.
- 4.5.3. **Arrangement**
A: two front direction indicator lamps of the following categories:
— 1 or 1 a or 1 b,
if the distance between the edge of the illuminating surface of this lamp and that of the illuminating surface of the dipped-beam headlamp and/or the front fog lamp, where fitted, is at least 40 mm,
— 1 a or 1 b,
if the distance between the edge of the illuminating surface of this lamp and that of the illuminating surface of the dipped-beam headlamp and/or the front fog lamp, where fitted, is greater than 20 mm and less than 40 mm,
— 1 b,
if the distance between the edge of the illuminating surface of this lamp and that of the illuminating surface of the dipped-beam headlamp and/or the front fog lamp, where fitted, is less than or equal to 20 mm;
two rear direction indicator lamps (category 2 a or 2 b);
two side direction indicator lamps (category 5).
Where any device combining the functions of a front indicator lamp (category 1, 1 a, and 1 b) and a side indicator lamp (category 5) has been installed, two additional side direction indicator lamps (category 5) may be installed to meet the visibility requirements of item 4.5.5.
- B: two rear direction indicator lamps (category 2 a or 2 b).

- 4.5.4. *Position*
- 4.5.4.1. *Width:*
- the edge of the illuminating surface furthest from the median longitudinal plane of the vehicle must not be more than 400 mm from the extreme outer edge of the vehicle.
- The distance between the inner edges of the two illuminating surfaces shall not be less than 600 mm.
- This distance may be reduced to 400 mm where the overall width of the vehicle is less than 1 300 mm.
- 4.5.4.2. *Height above the ground:*
- 4.5.4.2.1. the height of the light-emitting surface of the side direction indicator lamps (category 5) must not be less than 500 mm measured from the lowest point or more than 1 500 mm measured from the highest point.
- 4.5.4.2.2. The height of the direction indicator lamps of category 1, 1 a, 1 b, 2 a and 2 b, measured in accordance with item 3.8, shall not be less than 350 mm or more than 1 500 mm.
- 4.5.4.2.3. If the structure of the vehicle does not permit these upper limits, measured as specified above, to be respected, they may be increased to 2 300 mm for side direction indicator lamps of category 5 and to 2 100 mm for the direction indicator lamps of categories 1, 1 a, 1 b, 2 a and 2 b.
- 4.5.4.3. *Length:*
- the distance between the light-emitting surface of the side direction indicator lamp (category 5) and the transverse plane which marks the forward boundary of the vehicle's overall length, shall not exceed 1 800 mm.
- If the structure of the vehicle makes it impossible to comply with the minimum angles of visibility, this distance may be increased to 2 500 mm.
- 4.5.5. *Geometric visibility*
- Horizontal angles: see Appendix 4.
- Vertical angles: 15° above and below the horizontal.
- The vertical angle below the horizontal may be reduced to 5° if the lamps are less than 750 mm above the ground.
- 4.5.6. *Alignment*
- If individual specifications for installation are laid down by the manufacturer they must be observed.
- 4.5.7. *Electrical connections*
- Direction indicator lamps shall switch on independently of the other lamps. All direction indicator lamps on one side of a vehicle shall be switched on and off by means of one control and must flash in phase.
- 4.5.8. *Operational tell-tale*
- Mandatory for front and rear direction indicator lamps. It may be optical or auditory or both.
- If it is optical, it shall be a flashing light which, at least in the event of the malfunction of any of the front or rear direction indicator lamps, is either extinguished, or remains alight without flashing, or shows a marked change of frequency.
- If it is entirely auditory it shall be clearly audible and shall show a marked change of frequency, at least in the event of the malfunction of any of the front or rear direction indicator lamps.
- If a motor vehicle is equipped to draw a trailer, it must be fitted with a special optical operational tell-tale for the direction indicator lamps on the trailer unless the tell-tale of the drawing vehicle allows the failure of any one of the direction indicator lamps on the vehicle combination thus formed to be detected.
- 4.5.9. *Other requirements*
- The light shall be a flashing light flashing 90 ± 30 times per minute.
- Operation of the light-signal control shall be followed within not more than one second by the emission of light and within not more than one and one-half seconds by its first extinction. If a motor vehicle is equipped to draw a trailer, the control of the direction indicator lamps on the drawing vehicle shall also operate the indicator lamps of the trailer.
- In the event of failure, other than a short circuit, of one direction indicator lamp, the others must continue to flash but the frequency under this condition may be different from that specified.

- 4.6. **Hazard warning signal**
- 4.6.1. *Presence*
Presence
Mandatory.
- 4.6.2. *Number*
- 4.6.3. *Arrangement*
- 4.6.4. *Position*
- 4.6.4.1. *Width*
- 4.6.4.2. *Height*
- 4.6.4.3. *Length*
- 4.6.5. *Geometric visibility*
- 4.6.6. *Alignment*
- 4.6.7. *Electrical connections*
The signal shall be operated by means of a separate control enabling all the direction indicator lamps to flash in phase.
- 4.6.8. *Circuit-closed tell-tale*
Mandatory. Flashing warning light, which can operate in conjunction with the tell-tale(s) specified in item 4.5.8.
- 4.6.9. *Other requirements*
As specified in item 4.5.9. If a motor vehicle is equipped to draw a trailer the hazard warning signal control must also be capable of bringing the direction indicator lamps on the trailer into action. The hazard warning signal must be able to function even if the device which starts and stops the engine is in a position which makes it impossible to start the engine.
- 4.7. **Stop lamps**
- 4.7.1. *Presence*
Mandatory.
- 4.7.2. *Number*
Two.
- 4.7.3. *Arrangement*
No individual specifications.
- 4.7.4. *Position*
- 4.7.4.1. *Width:*
Not less than 600 mm apart. This distance may be reduced to 400 mm if the overall width of the vehicle is less than 1 300 mm.
- 4.7.4.2. *Height:*
Above the ground: not less than 350 mm, not more than 1 500 mm or not more than 2 100 mm if the shape of bodywork makes it impossible to keep within 1 500 mm.
- 4.7.4.3. *Length:*
At rear of vehicle.
- 4.7.5. *Geometric visibility*
Horizontal angle: 45° outwards and inwards.
Vertical angle: 15° above and below the horizontal.
The vertical angle below the horizontal may be reduced to 5° in the case of lamps less than 750 mm above the ground.
- 4.7.6. *Alignment*
Towards the rear of the vehicle.
- 4.7.7. *Electrical connections*
Stop lamps must light up when the service brake is applied. They need not function if the device which starts and/or stops the engine is in a position which makes it impossible for the engine to operate.

As specified in the corresponding headings of item 4.5.

- 4.7.8. *Operational tell-tale*
Optional. Where fitted, this tell-tale must be an operational tell-tale consisting of a non-flashing warning light which comes on in the event of the malfunctioning of the stop lamps.
- 4.8. **Rear registration plate lamp**
- 4.8.1. *Presence*
Mandatory.
- 4.8.2. *Number*
- 4.8.3. *Arrangement*
- 4.8.4. *Position*
- 4.8.4.1. *Width*
- 4.8.4.2. *Height*
- 4.8.4.3. *Length*
- 4.8.5. *Geometric visibility*
- 4.8.6. *Alignment*
- 4.8.7. *Electrical connections*
No individual specifications.
- 4.8.8. *Circuit-closed tell-tale*
Optional. If it exists, its function must be carried out by the tell-tale required for the front and rear position lamps.
- 4.8.9. *Other requirements*
When the rear registration plate lamp is combined with the rear position lamp reciprocally incorporated in the stop lamp or in the rear fog lamp, the photometric characteristics of the rear registration plate lamp may be modified during the operation of the stop lamp or the rear fog lamp.
- 4.9. **Front position lamps**
- 4.9.1. *Presence*
Mandatory on all motor vehicles.
Mandatory on trailers over 1 600 mm wide.
Optional on trailers which are not more than 1 600 mm wide.
- 4.9.2. *Number*
Two.
- 4.9.3. *Arrangement*
No individual specifications.
- 4.9.4. *Position*
- 4.9.4.1. *Width:*
the point on the illuminating surface which is farthest from the vehicle's median longitudinal plane must be not more than 400 mm from the extreme outer edge of the vehicle.
In the case of a trailer, the point on the illuminating surface which is farthest from the median longitudinal plane must be not more than 150 mm from the extreme outer edge of the vehicle. The clearance between the respective inner edges of the two illuminating surfaces must not be less than 600 mm.
This distance may be reduced to 400 mm where the overall width of the vehicle is less than 1 300 mm.
- 4.9.4.2. *Height:*
above the ground: not less than 350 mm, not more than 1 500 mm or not more than 2 100 mm if the shape of the bodywork makes it impossible to keep within 1 500 mm.
- 4.9.4.3. *Length:*
no individual specifications.

Such that the device is capable of illuminating the space for the registration plate.

- 4.9.4.4. Where the front position lamp and another lamp are mutually incorporated, the illuminating surface of the other lamp must be used to verify compliance with the positioning requirements (items 4.9.4.1 to 4.9.4.3).
- 4.9.5. *Geometric visibility*
Horizontal angle for the two front position lamps:
45° inwards and 80° outwards.
In the case of trailers, the angle inwards may be reduced to 5°.
Vertical angle:
15° above and below the horizontal. The vertical angle below the horizontal may be reduced to 5° in the case of lamps less than 750 mm above the ground.
- 4.9.6. *Alignment*
Towards the front.
- 4.9.7. *Electrical connections*
No individual specifications.
- 4.9.8. *Circuit-closed tell-tale*
Mandatory. This tell-tale shall be non-flashing and shall not be required if the instrument panel lighting can only be turned on simultaneously with the front position lamps.
- 4.10. **Rear position lamps**
- 4.10.1. *Presence*
Mandatory.
- 4.10.2. *Number*
Two.
- 4.10.3. *Arrangement*
No individual specifications.
- 4.10.4. *Position*
- 4.10.4.1. *Width:*
the point on the illuminating surface which is farthest from the vehicle's median longitudinal plane must be not more than 400 mm from the extreme outer edge of the vehicle.
The distance between the inner edges of the two illuminating surfaces shall be not less than 600 mm. This distance may be reduced to 400 mm where the overall width of the vehicle is less than 1 300 mm.
- 4.10.4.2. *Height:*
above the ground: not less than 350 mm, not more than 1 500 mm or not more than 2 100 mm if the shape of the bodywork makes it impossible to keep within 1 500 mm.
- 4.10.4.3. *Length:*
at rear of vehicle.
- 4.10.5. *Geometric visibility*
Horizontal angle: 45° inwards and 80° outwards.
Vertical angle: 15° above and below the horizontal.
The vertical angle below the horizontal may be reduced to 5° in the case of lamps less than 750 mm above the ground.
- 4.10.6. *Alignment*
Towards the rear.
- 4.10.7. *Electrical connections*
No individual specifications.
- 4.10.8. *Circuit-closed tell-tale*
Mandatory. It must be combined with that of the front position lamps.
- 4.11. **Rear fog lamp**
- 4.11.1. *Presence*
Mandatory.

- 4.11.2. *Number*
One, a second being optional.
- 4.11.3. *Arrangement*
No individual specifications.
- 4.11.4. *Position*
- 4.11.4.1. *Width:*
if there is only one rear fog lamp, it must be on the opposite side of the median longitudinal plane of the vehicle to the direction of traffic prescribed in the country of registration; the centre of reference may also be situated on the median longitudinal plane of the vehicle.
- 4.11.4.2. *Height:*
between 250 and 1 000 mm above the ground.
- 4.11.4.3. *Length:*
at rear of vehicle.
- 4.11.5. *Geometric visibility*
Horizontal angle: 25° inwards and outwards.
Vertical angle: 5° above and below the horizontal.
- 4.11.6. *Alignment*
Towards the rear.
- 4.11.7. *Electrical connections*
These must be such that the rear fog lamp can operate only when the dipped beam or main beam headlamps or the front fog lamps or a combination of these are switched on. They must be such that when the rear fog lamp is switched on it is capable of operating together with the main beam, the dipped beam and the front fog lamps.
When the rear fog lamp is on, switching from the main-beam to the dipped-beam mode and vice-versa shall not extinguish the rear fog lamp.
If the front fog lamps exist, the extinguishing of the rear fog lamp must be possible independently from that of the front fog lamps.
- 4.11.8. *Circuit-closed tell-tale*
Mandatory. An independent non-flashing warning light.
- 4.11.9. *Other requirements*
In all cases, the distance between the rear fog lamp and each stop lamp must be greater than 100 mm.
- 4.12. **Parking lamp**
- 4.12.1. *Presence*
On motor vehicles not exceeding 6 m in length and not exceeding 2 m in width: optional;
On all other vehicles: prohibited.
- 4.12.2. *Number*
Dependent upon the arrangement.
- 4.12.3. *Arrangement*
— either two front lamps and two rear lamps,
— or one lamp on each side.
- 4.12.4. *Position*
- 4.12.4.1. *Width:*
the point on the illuminating surface which is farthest from the median longitudinal plane of the vehicle must be not more than 400 mm from the extreme outer edge of the vehicle.
Furthermore, in the case of a pair of lamps, the lamps must be on the sides of the vehicle.
- 4.12.4.2. *Height:*
above the ground: not less than 350 mm;
not more than 1 500 mm, or 2 100 mm if the shape of the bodywork makes it impossible to keep within 1 500 mm.

- 4.12.4.3. **Length**
no individual specifications.
- 4.12.5. **Geometric visibility**
Horizontal angle: 45° outwards, towards the front and towards the rear.
Vertical angle: 15° above and below the horizontal. The vertical angle below the horizontal may be reduced to 5° in the case of lamps less than 750 mm above the ground.
- 4.12.6. **Alignment**
Such that the lamps meet the specified conditions concerning visibility towards the front and towards the rear.
- 4.12.7. **Electrical connections**
The connection must allow the parking lamp(s) on the same side of the vehicle to be lit independently of any other lamps.
The parking lamp(s) must be able to function even if the device which starts and/or stops the engine is in a position which makes it impossible for the engine to operate.
- 4.12.8. **Circuit-closed tell-tale**
Optional. If there is one, it must not be possible to confuse it with the tell-tale for the front and rear position lamps.
- 4.12.9. **Other requirements**
The function of this lamp may also be performed by simultaneously switching on the front and rear position lamps on the same side of the vehicle.
- 4.13. **End-outline marker lamp**
- 4.13.1. **Presence**
Mandatory on vehicles exceeding 2,10 m in width.
Optional on vehicles between 1,80 and 2,10 m wide.
The rear end-outline marker lamp is optional on chassis cabs.
- 4.13.2. **Number**
Two visible from the front and two visible from the rear.
- 4.13.3. **Arrangement**
No individual specifications.
- 4.13.4. **Position**
- 4.13.4.1. **Width:**
Front and rear: as close as possible to the extreme outer edge of the vehicle. This condition is deemed to have been met when the point on the illuminating surface which is farthest from the vehicle's median longitudinal plane is not more than 400 mm from the extreme outer edge of the vehicle.
- 4.13.4.2. **Height:**
Front: Motor vehicles: the horizontal plane tangential to the upper edge of the illuminating surface of the device must not be lower than the horizontal plane tangential to the upper edge of the transparent zone of the windscreen.
Trailers and semi-trailers: at the maximum height compatible with the requirements relating to the width, design and operational requirements of the vehicle and to the symmetry of the lamps.
Rear: at the maximum height compatible with the requirements relating to the width, design and operational requirements of the vehicle and to the symmetry of the lamps.
- 4.13.4.3. **Length:**
no individual specifications.
- 4.13.5. **Geometric visibility:**
Horizontal angle: 80° outwards.
Vertical angle: 5° above and 20° below the horizontal.
- 4.13.6. **Alignment**
Such that the lamps meet the visibility requirements towards the front and towards the rear.

- 4.13.7. *Electrical connections*
No individual specifications.
- 4.13.8. *Circuit-closed tell-tale*
Optional. If it exists, its function shall be carried out by the tell-tale required for the front and rear position lamps.
- 4.13.9. *Other requirements*
Subject to all other conditions being met, the lamp visible from the front and the lamp visible from the rear, on the same side of the vehicle, may be combined in one device.
The position of an end-outline marker lamp in relation to the corresponding position lamp shall be such that the distance between the projections on a transverse vertical plane of the points nearest to the illuminating surfaces of the two lamps considered is not less than 200 mm.
- 4.14. **Rear retro reflector, non-triangular**
- 4.14.1. *Presence*
Mandatory on motor vehicles.
Optional on trailers, provided that they are grouped together with the other rear light-signalling devices.
- 4.14.2. *Number*
Two.
Additional retro reflecting devices and materials are permitted provided they do not impair the effectiveness of the mandatory lighting and light-signalling devices.
- 4.14.3. *Arrangement*
No individual specifications.
- 4.14.4. *Position*
- 4.14.4.1. *Width:*
the point on the illuminating surface which is farthest from the vehicle's median longitudinal plane must be not more than 400 mm from the extreme outer edge of the vehicle.
The distance between the inner edges of the retro reflectors shall not be less than 600 mm. This distance may be reduced to 400 mm if the overall width of the vehicle is less than 1 300 mm.
- 4.14.4.2. *Height:*
above the ground: not less than 350 mm and not more than 900 mm.
- 4.14.4.3. *Length:*
At rear of vehicle.
- 4.14.5. *Geometric visibility*
Horizontal angle: 30° inwards and outwards.
Vertical angle: 15° above and below the horizontal. The vertical angle below the horizontal may be reduced to 5° in the case of a retro reflector less than 750 mm above the ground.
- 4.14.6. *Alignment*
To the rear.
- 4.14.7. *Other requirements*
The illuminating surface of the retro reflector may have parts in common with the illuminating surface of any other rear lamp.
- 4.15. **Rear retro reflector, triangular**
- 4.15.1. *Presence*
Mandatory on trailers.
Prohibited on motor vehicles.
- 4.15.2. *Number*
Two.
Additional retro reflecting devices and materials are permitted provided they do not impair the effectiveness of the mandatory lighting and light signalling devices.

- 4.15.3. *Arrangement*
The apex of the triangle must be uppermost.
- 4.15.4. *Position*
- 4.15.4.1. *Width:*
the point of the illuminating surface which is furthest from the vehicle's median longitudinal plane must not be further than 400 mm from the extreme outer edge of the vehicle.
The distance between the inner edges of the retro reflectors shall not be less than 600 mm. This distance may be reduced to 400 mm if the overall width of the vehicle is less than 1 300 mm.
- 4.15.4.2. *Height:*
above the ground: not less than 350 mm and not more than 900 mm.
- 4.15.4.3. *Length:*
at rear of vehicle.
- 4.15.5. *Geometric visibility:*
Horizontal angle: 30° inwards and outwards.
Vertical angle: 15° above and below the horizontal. The vertical angle below the horizontal may be reduced to 5° in the case of a retro reflector less than 750 mm above the ground.
- 4.15.6. *Alignment*
To the rear.
- 4.15.7. *Other requirements*
No lamp may be placed within the triangle.
- 4.16. **Front retro reflector, non-triangular**
- 4.16.1. *Presence*
Mandatory on trailers.
Optional on motor vehicles.
- 4.16.2. *Number*
Two.
Additional retro reflecting devices and materials are permitted provided they do not impair the effectiveness of the mandatory lighting and light-signalling devices.
- 4.16.3. *Arrangement*
No individual specifications.
- 4.16.4. *Position*
- 4.16.4.1. *Width:*
the point of the illuminating surface which is furthest from the vehicle's median longitudinal plane must not be further than 400 mm from the extreme outer edge of the vehicle.
In the case of a trailer, the point of the illuminating surface which is furthest from the vehicle's median longitudinal plane must not be further than 150 mm from the extreme outer edge of the vehicle.
The distance between the inner edges of the retro reflectors shall not be less than 600 mm. This distance may be reduced to 400 mm if the overall width of the vehicle is less than 1 300 mm.
- 4.16.4.2. *Height:*
above the ground: not less than 350 mm and not more than 900 mm, or if 1 500 mm if the structure of the vehicle makes it impossible to keep within 900 mm.
- 4.16.4.3. *Length:*
at front of vehicle.
- 4.16.5. *Geometric visibility:*
Horizontal angle: 30° inwards and outwards.
If, on account of adjustable drawbars, it is not possible to satisfy the inward angle requirement of 30°, it may be reduced to 10°.
Vertical angle: 15° above and below the horizontal. The vertical angle below the horizontal may be reduced to 5° in the case of a retro reflector less than 750 mm above the ground.

- 4.16.6. *Alignment*
Towards the front.
- 4.16.7. *Other requirements*
The illuminating surface of the retro reflector may have parts in common with that of the front position lamp.
- 4.17. **Side retro reflector, non-triangular**
- 4.17.1. *Presence*
Mandatory:
— on all motor vehicles the length of which exceeds 6 m,
— on all trailers;
Optional:
— on motor vehicles the length of which does not exceed 6 m.
- 4.17.2. *Minimum number per side*
Such that the rules for longitudinal positioning are complied with.
Additional retro reflecting devices and materials are permitted provided they do not impair the effectiveness of the mandatory lighting and light signalling devices.
- 4.17.3. *Arrangement*
No individual specifications.
- 4.17.4. *Position*
- 4.17.4.1. *Width:*
no individual specifications.
- 4.17.4.2. *Height:*
above the ground: not less than 350 mm and not more than 900 mm. If the structure of the vehicle does not allow compliance with the maximum height, this limit may be raised to 1 500 mm.
- 4.17.4.3. *Length:*
at least one side retro reflector must be fitted to the middle third of the vehicle, the foremost side retro reflector being not further than 3 m from the front; in the case of trailers, account shall be taken of the length of the drawbar for the measurement of this distance.
The distance between two adjacent side retro reflectors shall not exceed 3 m.
If the structure of the vehicle makes it impossible to comply with such a requirement, this distance may be increased to 4 m. The distance between the rearmost side retro reflector and the rear of the vehicle shall not exceed 1 m.
However, for motor vehicles the length of which does not exceed 6 m, it is sufficient to have one side retro reflector fitted within the first third and/or one within the last third of the vehicle length.
- 4.17.5. *Geometric visibility*
Horizontal angle: 45° to the front and to the rear.
Vertical angle: 15° above and below the horizontal. The vertical angle below the horizontal may be reduced to 5° in the case of a retro reflector less than 750 mm above the ground.
- 4.17.6. *Alignment*
The reference axis of the retro reflector must be horizontal and perpendicular to the vehicle's median longitudinal plane and directed outwards.
- 4.17.7. *Other requirements*
The illuminating surface of the side retro reflector may have parts in common with the illuminating surface of any other side lamp.
- 4.18. **Side-marker lamp**
- 4.18.1. *Presence*
Mandatory:
— on all vehicles the length of which exceeds 6 m, except for chassis-cabs;

Optional:

— on vehicles the length of which does not exceed 6 m.

The length of trailers is calculated including the drawbar.

4.18.2. *Minimum number per side*

Such that the rules for longitudinal positioning are complied with.

4.18.3. *Arrangement*

No individual specifications.

4.18.4. *Position*

4.18.4.1. *Width:*

no individual specifications.

4.18.4.2. *Height:*

above the ground: not less than 350 mm and not more than 1 500 mm. If the structure of the vehicle does not allow of compliance with the maximum height, this limit may be raised to 2 100 mm.

4.18.4.3. *Length:*

at least one side-marker lamp must be fitted to the middle third of the vehicle, the foremost side-marker lamp being not further than 3 m from the front; in the case of trailers account shall be taken of the length of the drawbar for the measurement of this distance.

The distance between two adjacent side-marker lamps shall not exceed 3 m.

If the structure of the vehicle makes it impossible to comply with such a requirement, this distance may be increased to 4 m. The distance between the rearmost side-marker lamp and the rear of the vehicle shall not exceed 1 m. However, for vehicles the length of which does not exceed 6 m and for chassis-cabs, it is sufficient to have one side-marker lamp fitted within the first third and/or one within the last third of the vehicle length.

4.18.5. *Geometric visibility*

Horizontal angle: 45° to the front and to the rear; however, for vehicles on which the installation of the side-marker lamps is optional this value can be reduced to 30°.

Vertical angle: 10° above and below the horizontal. The vertical angle below the horizontal may be reduced to 5° in the case of a side-marker lamp less than 750 mm above the ground.

4.18.6. *Alignment*

Towards the side.

4.18.7. *Electrical connections*

No individual specifications.

4.18.8. *Circuit-closed tell-tale*

Optional. If it exists its function shall be carried out by the tell-tale required for the front and rear position lamps.

4.18.9. *Other requirements*

When the rearmost side-marker lamp is combined with the rear position lamp reciprocally incorporated with the rear fog lamp or it is reciprocally incorporated in this lamp, the photometric characteristics of the side-marker lamp may be modified during the operation of the rear fog lamp.

5. CONFORMITY OF PRODUCTION

5.1. Every series-produced vehicle must conform to the vehicle type which received type-approval as regards the installation of lighting and light-signalling devices and their characteristics as specified by this Directive.

Appendix 1

VEHICLE LOADING CONDITIONS REFERRED TO IN 4.2.6.1

1. For the following tests, the mass of the passengers shall be calculated on the basis of 75 kg per person.
2. Loading conditions for different kinds of vehicles:
 - 2.1. *Vehicles in category M₁.*
 - 2.1.1. The angle of the light beam of the dipped-beam headlamps shall be determined under the following load conditions:
 - 2.1.1.1. one person in the driver's seat;
 - 2.1.1.2. the driver, plus one passenger in the front seat farthest from the driver;
 - 2.1.1.3. the driver, one passenger in the front seat farthest from the driver, all the seats farthest to the rear occupied;
 - 2.1.1.4. all the seats occupied;
 - 2.1.1.5. all the seats occupied, plus an evenly distributed load in the luggage boot, in order to obtain the permissible load on the rear axle or on the front axle if the boot is at the front. If the vehicle has a front and a rear boot, the additional load must be appropriately distributed in order to obtain the permissible axle loads. However, if the maximum permissible laden mass is obtained before the permissible load on one of the axles, the loading of the boot(s) shall be limited to the figure which enables that mass to be reached;
 - 2.1.1.6. driver, plus an evenly distributed load in the boot, in order to obtain the permissible load on the corresponding axle.

However, if the maximum permissible laden mass is obtained before the permissible load on the axle, the loading of the boot(s) shall be limited to the figure which enables that mass to be reached.
 - 2.1.2. In determining the above loading conditions, account must be taken of any loading restrictions laid down by the manufacturer.
 - 2.2. *Vehicles in categories M₂ and M₃.*

The angle of the light beam from the dipped-beam headlamps must be determined under the following loading conditions:

 - 2.2.1. Vehicle unladen and one person in the driver's seat.
 - 2.2.2. Vehicles laden such that each axle carries its maximum technically permissible load or until the maximum permissible mass of the vehicle is attained by loading the front and rear axles proportionally to their maximum technically permissible loads, whichever occurs first.
 - 2.3. *Vehicles in category N with load surfaces.*
 - 2.3.1. The angle of the light beam from the dipped-beam headlamps must be determined under the following loading conditions:
 - 2.3.1.1. vehicle unladen and one person in the driver's seat,
 - 2.3.1.2. in the case of a load platform at the rear: driver, plus a load so distributed as to give the maximum technically permissible load on the rear axle or axles, or the maximum permissible mass of the vehicle, whichever occurs first, without exceeding a front axle load calculated as the sum of the front axle load of the unladen vehicle plus 25 % of the maximum permissible payload on the front axle. The same procedure shall apply, *mutatis mutandis*, when the load platform is at the front.
 - 2.4. *Vehicles in category N without load surface.*
 - 2.4.1. Drawing vehicles for semi-trailers:
 - 2.4.1.1. unladen vehicle without a load on the coupling attachment and one person in the driver's seat,
 - 2.4.1.2. one person in the driver's seat; technically permissible load on the coupling attachment in the position of the attachment corresponding to the highest load on the rear axle.
 - 2.4.2. Drawing vehicles for trailers:
 - 2.4.2.1. vehicle unladen and one person in the driver's seat;
 - 2.4.2.2. one person in the driver's seat, all the other places in the driving cabin being occupied.

Appendix 2

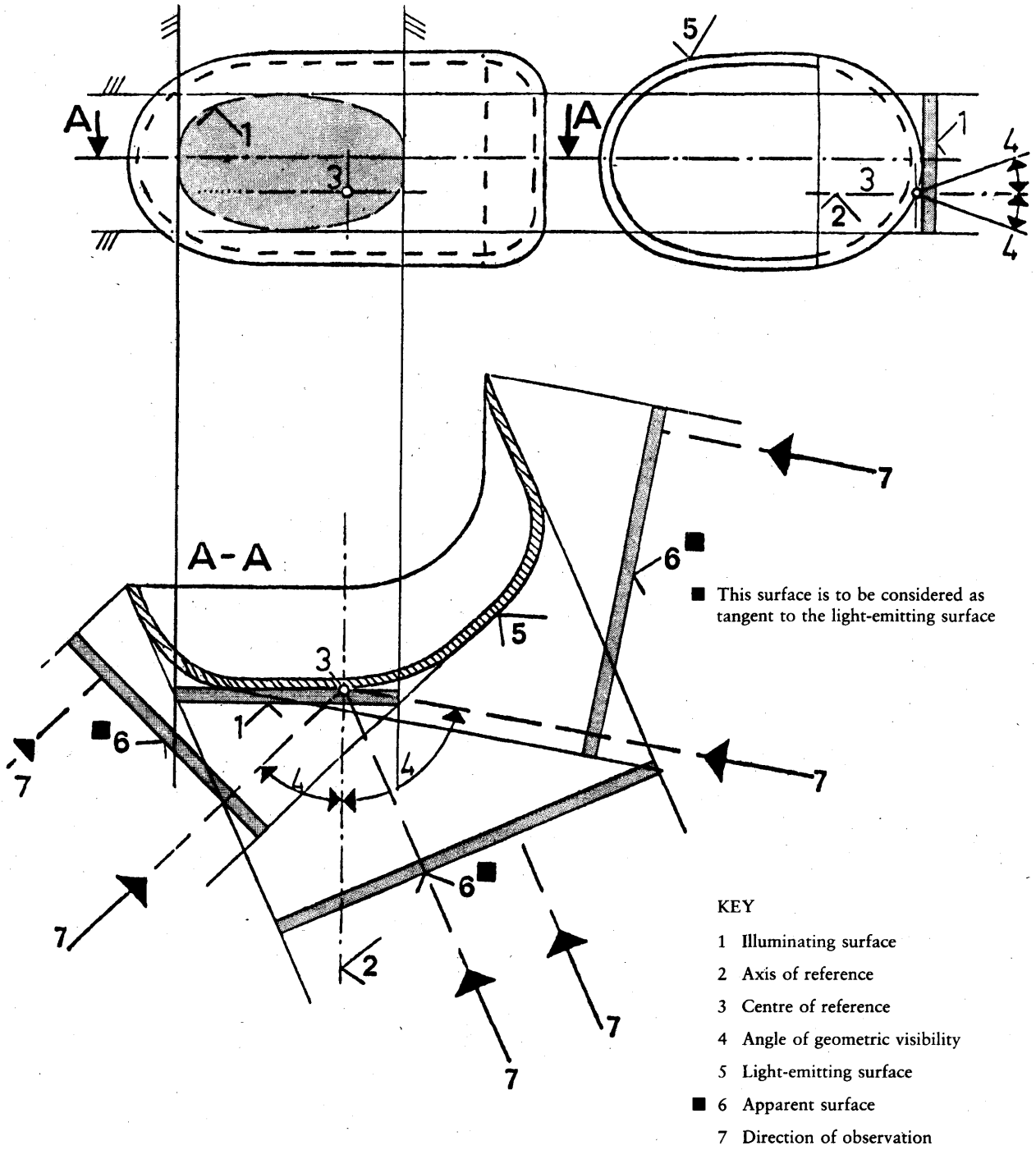

Appendix 3

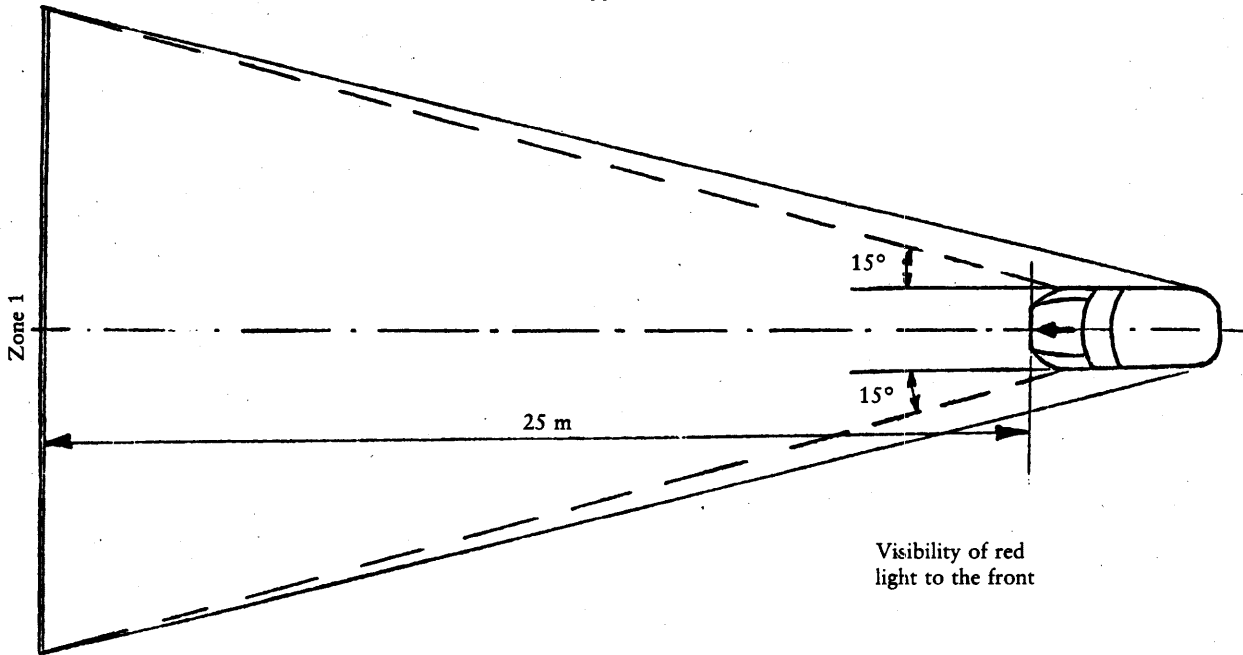

Figure 1

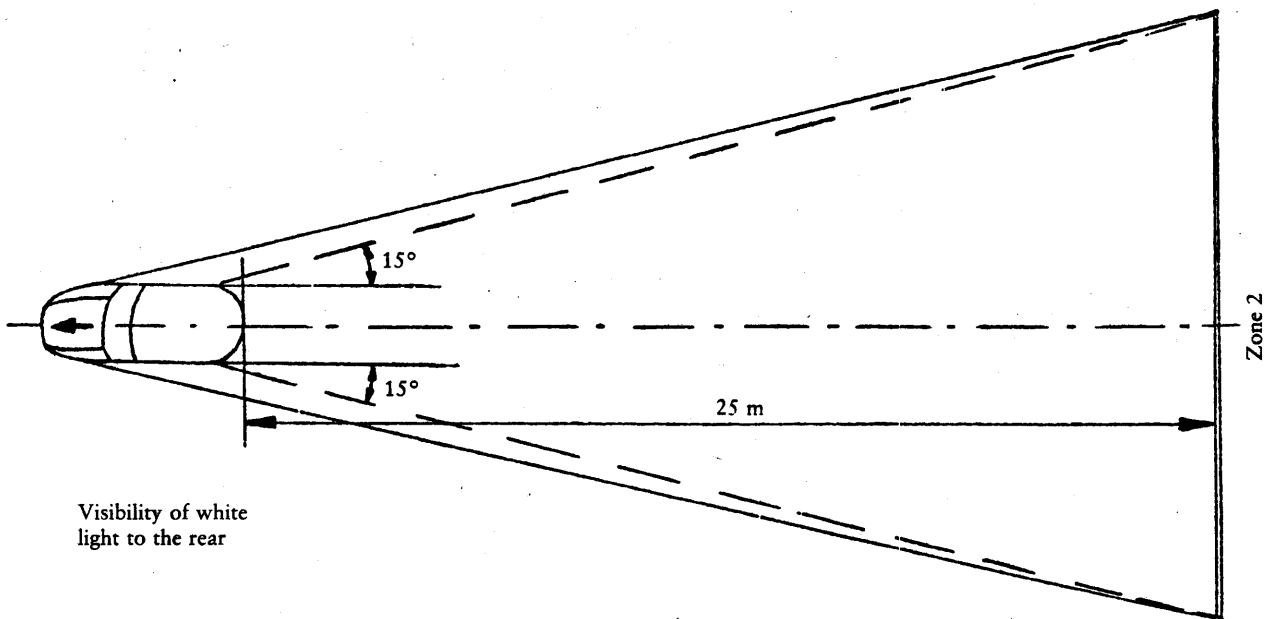
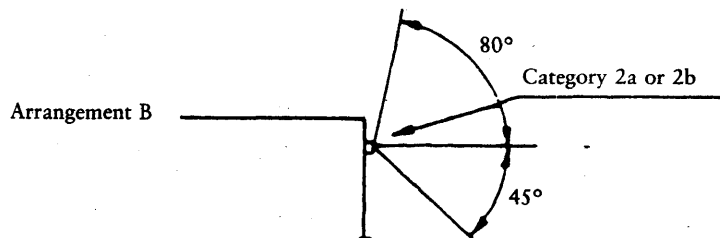
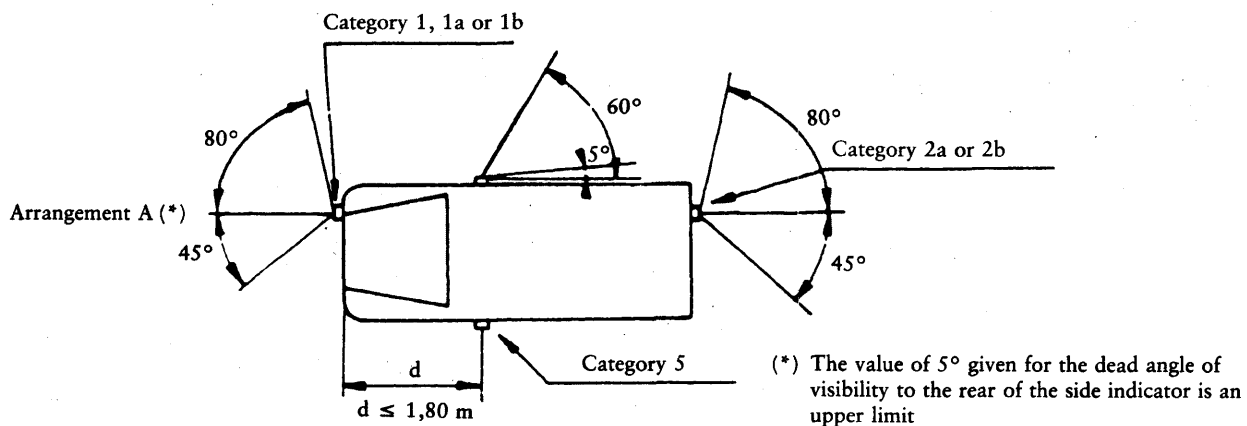

Figure 2

Appendix 4

DIRECTION INDICATOR LAMP

Angles of geometric visibility



Appendix 5

MEASUREMENT OF THE VARIATION OF DIPPED BEAM INCLINATION AS A FUNCTION OF LOAD

1. SCOPE

This Appendix specifies a method for measuring variations in motor vehicle dipped beam inclination, in relation to its initial inclination, caused by changes in vehicle attitude due to loading.

2. DEFINITIONS

2.1. Initial inclination

2.1.1. Stated initial inclination:

the value of the dipped beam initial inclination specified by the motor vehicle manufacturer serving as a reference value for the calculation of permissible variations.

2.1.2. Measured initial inclination:

the mean value of dipped beam inclination or vehicle inclination measured with the vehicle in condition No 1, as defined in Appendix 1, for the category of vehicle under test. It serves as a reference value for the assessment of variations in beam inclination as the load varies.

2.2. Dipped-beam inclination

It may be defined as follows:

- either as the angle, expressed in milliradians, between the direction of the beam towards a characteristic point on the horizontal part of the cut-off in the luminous distribution of the headlamp and the horizontal plane,
- or by the tangent of that angle, expressed in percentage inclination, since the angles are small (for these small angles, 1 % is equal to 10 mrad).

If the inclination is expressed in percentage inclination, it can be calculated by means of the following formula:

$$\frac{h_1 - h_2}{l} \times 100$$

where:

h_1 is the height above the ground, in millimetres, of the abovementioned characteristic point, measured on a vertical screen perpendicular to the vehicle longitudinal median plane, placed at a horizontal distance l ;

h_2 is the height above the ground, in millimetres, of the centre of reference (which is taken to be the nominal origin of the characteristic point chosen in h_1);

l is the distance, in millimetres, from the screen to the centre of reference.

Negative values denote downward inclination (see Figure 1).

Positive values denote upward inclination.

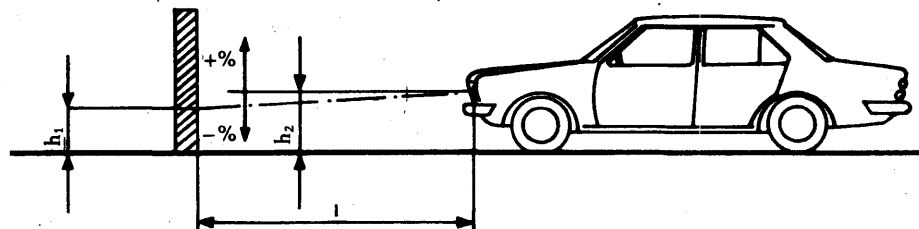

Figure 1

Notes:

1. This drawing represents a category M_1 vehicle, but the principle shown applies equally to vehicles of other categories.
2. Where the vehicle does not incorporate a headlamp levelling system, the variation in dipped beam inclination is identical with the variation in the inclination of the vehicle itself.

3. MEASUREMENT CONDITIONS

- 3.1. If a visual inspection of the dipped beam pattern on the screen or a photometric method is used, measurement shall be carried out in a dark environment (for example, a dark room) of sufficient area to allow the vehicle and the screen to be placed as shown in Figure 1. Headlamp centres of reference shall be at a distance I from the screen of at least 10 m.
- 3.2. The ground on which measurements are made shall be as flat and horizontal as possible, so that the reproducibility of measurement of dipped beam inclination can be assured with an accuracy of $\pm 0,5$ mrad ($\pm 0,05\%$ inclination).
- 3.3. If a screen is used, its marking, position and orientation in relation to the ground and to the median longitudinal plane of the vehicle, shall be such that the reproducibility of the measurement of the dipped beam inclination can be assured with an accuracy of $\pm 0,5$ mrad ($\pm 0,05\%$ inclination).
- 3.4. During measurements, the ambient temperature shall be between 10 and 30° C.

4. VEHICLE PREPARATION

- 4.1. Measurements shall be carried out on a vehicle which has travelled a distance of between 1 000 and 10 000 km, preferably 5 000 km.
- 4.2. Tyres shall be inflated to the full-load pressure specified by the vehicle manufacturer. The vehicle shall be fully replenished (fuel, water, oil) and equipped with all the accessories and tools specified by the manufacturer. Full fuel replenishment means that the fuel tank must be filled to not less than 90 % of its capacity as indicated in the information document, a model of which appears in Annex I to Directive 70/156/EEC.
- 4.3. The vehicle shall have the parking brake released and the gearbox in neutral.
- 4.4. The vehicle shall be conditioned for at least eight hours at the temperature specified in item 3.4.
- 4.5. If a photometric or visual method is used, headlamps with a well-defined dipped beam cut-off should preferably be installed on the vehicle under test in order to facilitate the measurements.
- Other means are allowed to obtain a more precise reading (for example, removal of the headlamp lens).

5. TEST PROCEDURE

5.1. General

The variations in either dipped beam or vehicle inclination, depending on the method chosen, shall be measured separately for each side of the vehicle. The results obtained from both left and right headlamps under all the load conditions specified in Appendix 1, shall be within the limits set out in item 5.5. The load shall be applied gradually without subjecting the vehicle to excessive shocks.

5.2. Determination of the measured initial inclination

The vehicle shall be prepared as specified in item 4 and laden as specified in Appendix 1 (first loading condition of the respective vehicle category).

Before each measurement, the vehicle shall be rocked as specified in item 5.4.

Measurement shall be made three times.

- 5.2.1. If none of the three measured results differs by more than 2 mrad (0,2% inclination) from the arithmetic mean of the results, that mean shall constitute the final result.
- 5.2.2. If any measurement differs from the arithmetic mean of the results by more than 2 mrad (0,2% inclination), a further series of 10 measurements shall be made, the arithmetic mean of which shall constitute the final result.

5.3. Measurement methods

Any method may be used to measure variations of inclination provided that the readings are accurate to within $\pm 0,2$ mrad ($\pm 0,02\%$ inclination).

5.4. Treatment of vehicle in each loading condition

The vehicle suspension and any other part likely to affect dipped beam inclination shall be activated according to the methods described below.

However, the technical authorities and manufacturers may jointly propose other methods (either experimental or based upon calculations), especially when the test poses particular problems, provided such calculations are clearly valid.

5.4.1. *M₁ category vehicles with conventional suspension*

With the vehicle standing on the measuring site and, if necessary, with the wheels resting on floating platforms (which must be used if their absence would lead to restriction of the suspension movement likely to affect the results of measurements), rock the vehicle continuously for at least three complete cycles; for each cycle, first the rear and then the front end of the vehicle is pushed down.

The rocking sequence shall end with the completion of a cycle. Before making the measurements, the vehicle shall be allowed to come to rest spontaneously.

Instead of using floating platforms, the same effect can be achieved by moving the vehicle backwards and forwards for at least a complete wheel revolution.

5.4.2. *M₂, M₃ and N category vehicles with conventional suspension*

5.4.2.1. If the treatment method for category M₁ vehicles described in item 5.4.1 is not possible, the method described in item 5.4.2.2 or 5.4.2.3 may be used.

5.4.2.2. With the vehicle standing on the measuring site and the wheels on the ground, rock the vehicle by temporarily varying the load.

5.4.2.3. With the vehicle standing on the measuring site and the wheels on the ground, activate the vehicle suspension and all other parts which may affect the dipped beam inclination by using a vibration rig. This can be a vibrating platform on which the wheels rest.

5.4.3. *Vehicles with non-conventional suspension, where the engine has to be running*

Before making any measurement wait until the vehicle has assumed its final attitude with the engine running.

5.5. **Measurements**

The variation of the inclination of the dipped beam shall be assessed for each of the different loading conditions in relation to the measured initial inclination determined in accordance with item 5.2.

If the vehicle is fitted with a manual headlamp-levelling system, the latter shall be adjusted to the positions specified by the manufacturer for given loading conditions (according to Appendix 1).

5.5.1. To begin with, a single measurement shall be made in each loading condition. Requirements have been met if, for all the loading conditions, the variation in inclination is within the calculated limits (for example, within the difference between the stated initial inclination and the lower and upper limits specified for approval) with a safety margin of 4 mrad (0,4% inclination).

5.5.2. If the result(s) of any measurement(s) does (do) not lie within the safety margin indicated in item 5.5.1 or exceed(s) the limit values, a further three measurements shall be made in the loading conditions corresponding to this (these) result(s) as specified in item 5.5.3.

5.5.3. *For each of the above loading conditions:*

5.5.3.1. If none of the three measured results differs by more than 2 mrad (0,2% inclination), from the arithmetic mean of the results, that mean shall constitute the final result.

5.5.3.2. If any measurement differs from the arithmetic mean of the results by more than 2 mrad (0,2% inclination), a further series of 10 measurements shall be made, the arithmetic mean of which shall constitute the final result.

5.5.3.3. If a vehicle is fitted with an automatic headlamp-levelling system which has an inherent hysteresis loop, average results at the top and bottom of the hysteresis loop shall be taken as significant values.

All these measurements shall be made in accordance with items 5.5.3.1 and 5.5.3.2.

5.5.4. Requirements have been met, if, under all loading conditions, the variation between the measured initial inclination determined in accordance with item 5.2 and the inclination measured under each loading condition is less than the values calculated in item 5.5.1 (without safety margin).

5.5.5. If only one of the calculated upper or lower limits of variation is exceeded, the manufacturer shall be permitted to choose a different value for the stated initial inclination, within the limits specified for approval.

Appendix 6

INDICATION OF THE STATED INITIAL ADJUSTMENT REFERRED TO IN ITEM 4.2.6.1 OF ANNEX I

Example

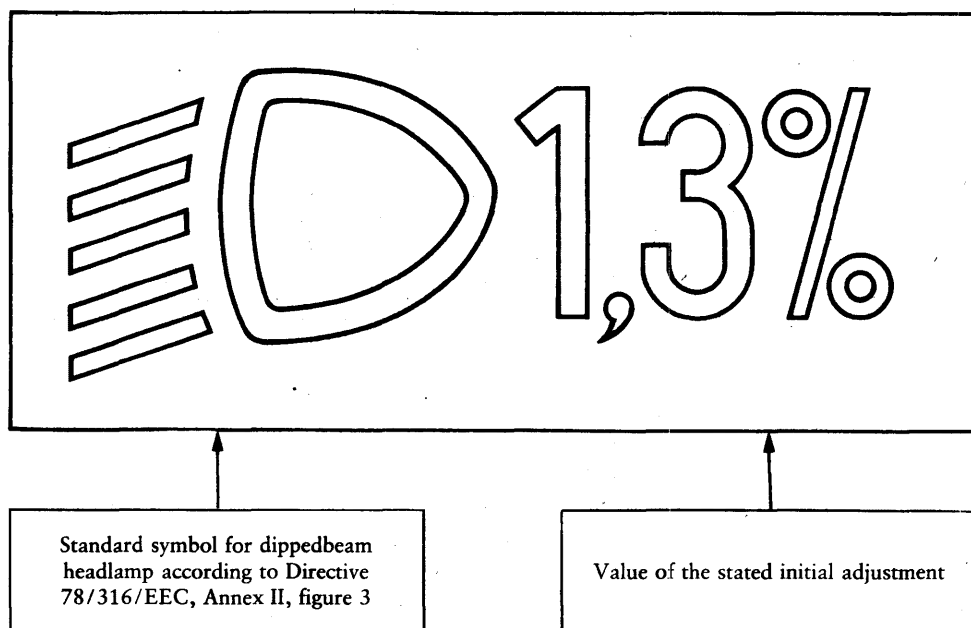

The size of the symbol and characters is left to the discretion of the manufacturer.

Appendix 7

THE CONTROLS FOR THE HEADLAMP-LEVELLING DEVICES REFERRED TO IN ITEMS 4.2.6.2.2 OF ANNEX I

1. SPECIFICATIONS

1.1. Downward inclination of the dipped beam must in all cases be produced in one of the following ways:

- (a) by moving a control downwards or to the left;
- (b) by rotating a control in a counter-clockwise direction;
- (c) by depressing a button (push-pull control).

If several buttons are used to adjust the beam, the button which gives the greatest downward inclination must be installed to the left or below the button(s) for other dipped-beam positions.

A rotary control which is installed edge-on, or with only the edge visible, should follow the operating principles of controls of types (a) or (c).

1.1.1. This control must carry symbols indicating clearly the movements corresponding to the downward and upward inclination of the dipped beam.

1.2. The '0' position corresponds to the initial inclination according to item 4.2.6.1 of Annex I.

1.3. The '0' position which, according to item 4.2.6.2.2 of Annex I, has to be a 'stop position', need not necessarily be at the end of the scale.

1.4. The marks used on the control must be explained in the owner's handbook.

1.5. Only the following symbols may be used to identify the controls:



Symbols employing four lines instead of five may also be used.

2. EXAMPLES

Example 1

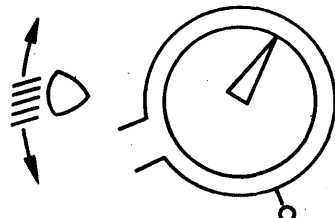

Example 2

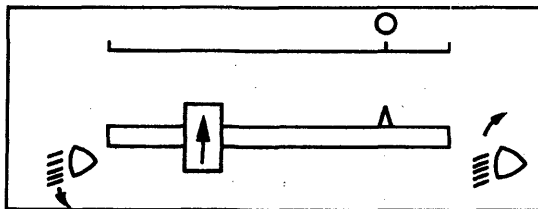

Example 3

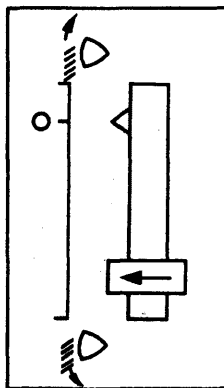

ANNEX II

MODEL

Name of administration

**ANNEX TO THE EC TYPE-APPROVAL CERTIFICATE FOR A VEHICLE TYPE WITH REGARD TO THE
INSTALLATION OF LIGHTING AND LIGHT-SIGNALLING DEVICES**

(Articles 4 (2) and 10 of Council Directive 70/156/EEC of 6 February 1970 on the approximation of the laws of
the Member States relating to the type-approval of motor vehicles and their trailers)

EC type-approval No

1. Make (trade name):
2. Vehicle type and trade name:
3. Manufacturer's name and address:
4. If applicable, name and address of manufacturer's representative:
5. Lighting equipment installed on the vehicle submitted for approval ⁽¹⁾:
 - 5.1. Main-beam headlamps: yes/no (*)
 - 5.2. Dipped-beam headlamps: yes/no (*)
 - 5.2.1. Headlamp levelling device: yes/no (*)
 - 5.3. Front fog lamps: yes/no (*)
 - 5.4. Reversing lamps: yes/no (*)
 - 5.5. Front direction indicator lamps: yes/no (*)
 - 5.6. Rear direction indicator lamps: yes/no (*)
 - 5.7. Side direction indicator lamps: yes/no (*)
 - 5.8. Hazard warning device: yes/no (*)
 - 5.9. Stop lamps: yes/no (*)
 - 5.10. Rear registration plate lamp: yes/no (*)
 - 5.11. Front position lamps: yes/no (*)
 - 5.12. Rear position lamps: yes/no (*)
 - 5.13. Rear fog lamps: yes/no (*)
 - 5.14. Parking lamps: yes/no (*)
 - 5.15. End-outline marker lamps: yes/no (*)

⁽¹⁾ Annex the lay-out drawings for the vehicle, as mentioned in item 2.2.3 of Annex I.

(*) Delete where inapplicable.

- 5.16. Rear retro reflectors, non-triangular: yes/no (*)
- 5.17. Rear retro reflectors, triangular: yes/no (*)
- 5.18. Front retro reflectors, non-triangular: yes/no (*)
- 5.19. Side retro reflectors, non-triangular: yes/no (*)
- 5.20. Side-marker lamps: yes/no (*)
- 5.21. Loading restrictions:
- 6. Equivalent lamps: yes/no (*) (see 15)
-
- 7. Vehicle submitted for approval on:
- 8. Technical service conducting the EC type-approval tests:
-
- 9. Date of report issued by that service:
- 10. Number of report issued by that service:
- 11. EC type-approval with regard to the lighting and light-signalling devices is granted/refused (*)
- 12. Place:
- 13. Date:
- 14. Signature:
- 15. The following documents, bearing the type-approval number indicated above, are annexed to this type-approval certificate:
.....
list(s) of devices foreseen by the manufacturer for lighting and light-signalling; for each device the manufacturer's mark and the component type-approval mark are indicated.
If expressly requested, these documents must be supplied to the competent authorities of the other Member States.
- 16. Remarks:
-
-
-
-

(*) Delete where inapplicable.