

# Official Journal of the European Union

L 285



English edition

Legislation

Volume 59

20 October 2016

Contents

II *Non-legislative acts*

ACTS ADOPTED BY BODIES CREATED BY INTERNATIONAL AGREEMENTS

- ★ **Regulation No 67 of the Economic Commission for Europe of the United Nations (UNECE) — Uniform provisions concerning the I. Approval of specific equipment of vehicles of category M and N using liquefied petroleum gases in their propulsion system; II. Approval of vehicles of category M and N fitted with specific equipment for the use of liquefied petroleum gases in their propulsion system with regard to the installation of such equipment [2016/1829] .....** 1

EN

Acts whose titles are printed in light type are those relating to day-to-day management of agricultural matters, and are generally valid for a limited period.

The titles of all other acts are printed in bold type and preceded by an asterisk.



## II

(Non-legislative acts)

## ACTS ADOPTED BY BODIES CREATED BY INTERNATIONAL AGREEMENTS

Only the original UN/ECE texts have legal effect under international public law. The status and date of entry into force of this Regulation should be checked in the latest version of the UN/ECE status document TRANS/WP.29/343, available at:

<http://www.unece.org/trans/main/wp29/wp29wgs/wp29gen/wp29fdocstts.html>

**Regulation No 67 of the Economic Commission for Europe of the United Nations (UNECE) — Uniform provisions concerning the I. Approval of specific equipment of vehicles of category M and N using liquefied petroleum gases in their propulsion system; II. Approval of vehicles of category M and N fitted with specific equipment for the use of liquefied petroleum gases in their propulsion system with regard to the installation of such equipment [2016/1829]**

Incorporating all valid text up to:

Supplement 14 to the 01 series of amendments — Date of entry into force: 9 October 2014

### CONTENTS

#### REGULATION

1. Scope
2. Definition and classification of components
  - Part I: Approval of specific equipment of vehicles of categories M and N using liquefied petroleum gases in their propulsion system
3. Application for approval
4. Markings
5. Approval
6. Specifications regarding the various components of the LPG equipment
7. Modifications of a type of LPG equipment and extension of approval
8. (Not allocated)
9. Conformity of production
10. Penalties for non-conformity of production
11. Transitional provisions regarding the various components of the LPG equipment
12. Production definitively discontinued
13. Names and addresses of Technical Services responsible for conducting approval tests, and of Type Approval Authorities

Part II: Approval of vehicles of categories M and N fitted with specific equipment for the use of liquefied petroleum gases in their propulsion system with regard to the installation of such equipment

14. Definitions
15. Application for approval
16. Approval
17. Requirements for the installation of specific equipment for the use of liquefied petroleum gases in the propulsion system of a vehicle
18. Conformity of production
19. Penalties for non-conformity of production
20. Modification and extension of approval of a vehicle type
21. Production definitively discontinued
22. Transitional provisions regarding the installation of various components of the LPG equipment and the type approval of a vehicle fitted with specific equipment for the use of liquefied petroleum gas in its propulsion system with regard to the installation of such equipment
23. Names and addresses of Technical Services responsible for conducting approval tests, and of Type Approval Authorities

ANNEXES

- 1 Essential characteristics of the vehicle, engine and LPG related equipment
- 2A Arrangement of the LPG equipment type approval mark
- 2B Communication concerning the approval or extension or refusal or withdrawal of approval or production definitively discontinued of a type of LPG equipment pursuant to Regulation No 67
- 2C Arrangement of approval marks
- 2D Communication concerning the approval or extension or refusal or withdrawal of approval or production definitively discontinued of a vehicle type with regard to the installation of LPG systems pursuant to Regulation No 67
- 3 Provisions regarding the approval of LPG container accessories
- 4 Provisions regarding the approval of the fuel pump
- 5 Provisions regarding the approval of the LPG filter unit
- 6 Provisions regarding the approval of the pressure regulator and the vaporiser
- 7 Provisions regarding the approval of the shut-off valve, the non-return valve, the gas-tube pressure relief valve and the service coupling
- 8 Provisions regarding the approval of flexible hoses with couplings
- 9 Provisions regarding the approval of the filling unit
- 10 Provisions regarding the approval of LPG containers
- 11 Provisions regarding the approval of gas injection devices, or gas mixing pieces, or injectors and the fuel rail
- 12 Provisions regarding the approval of the gas dosage unit when not combined with the gas injection device(s)
- 13 Provisions regarding the approval of the pressure and/or temperature sensor
- 14 Provisions regarding the approval of the electronic control unit

- 15 Test procedures
- 16 Provisions regarding LPG identification mark for M<sub>2</sub> and M<sub>3</sub> category vehicles
- 17 Provisions regarding identification mark for service coupling

1. SCOPE

This Regulation applies to:

- 1.1. Part I Approval of specific equipment of vehicles of category M and N <sup>(1)</sup> using liquefied petroleum gases in their propulsion system;
- 1.2. Part II Approval of vehicles of category M and N <sup>(1)</sup> fitted with specific equipment for the use of liquefied petroleum gases in their propulsion system with regard to the installation of such equipment.

2. DEFINITION AND CLASSIFICATION OF COMPONENTS

LPG components for use in vehicles shall be classified with regard to the maximum operating pressure and function, according to Figure 1.

Class 0 High pressure parts including tubes and fittings containing liquid LPG with a pressure > 3 000 kPa.

Class 1 High pressure parts including tubes and fittings containing liquid LPG at vapour pressure or increased vapour pressure up to 3 000 kPa.

Class 2 Low pressure parts including tubes and fittings containing vaporised LPG with a maximum operating pressure below 450 kPa and over 20 kPa above atmospheric pressure.

Class 2A Low pressure parts for a limited pressure range including tubes and fittings containing vaporised LPG with a maximum operating pressure below 120 kPa and over 20 kPa above atmospheric pressure.

Class 3 Shut-off valves and pressure relief valves, when operating in the liquid phase.

LPG components designed for a maximum operating pressure below 20 kPa above atmospheric pressure are not subjected to this Regulation.

A component can consist of several parts, each part classified in his own class with regard to maximum operating pressure and function.

---

<sup>(1)</sup> As defined in the Consolidated Resolution on the Construction of Vehicles (R.E.3.), document ECE/TRANS/WP.29/78/Rev.3, para. 2 — [www.unece.org/trans/main/wp29/wp29wgs/wp29gen/wp29resolutions.html](http://www.unece.org/trans/main/wp29/wp29wgs/wp29gen/wp29resolutions.html)

Figure 1

## Classification with regard to maximum operating pressure and function

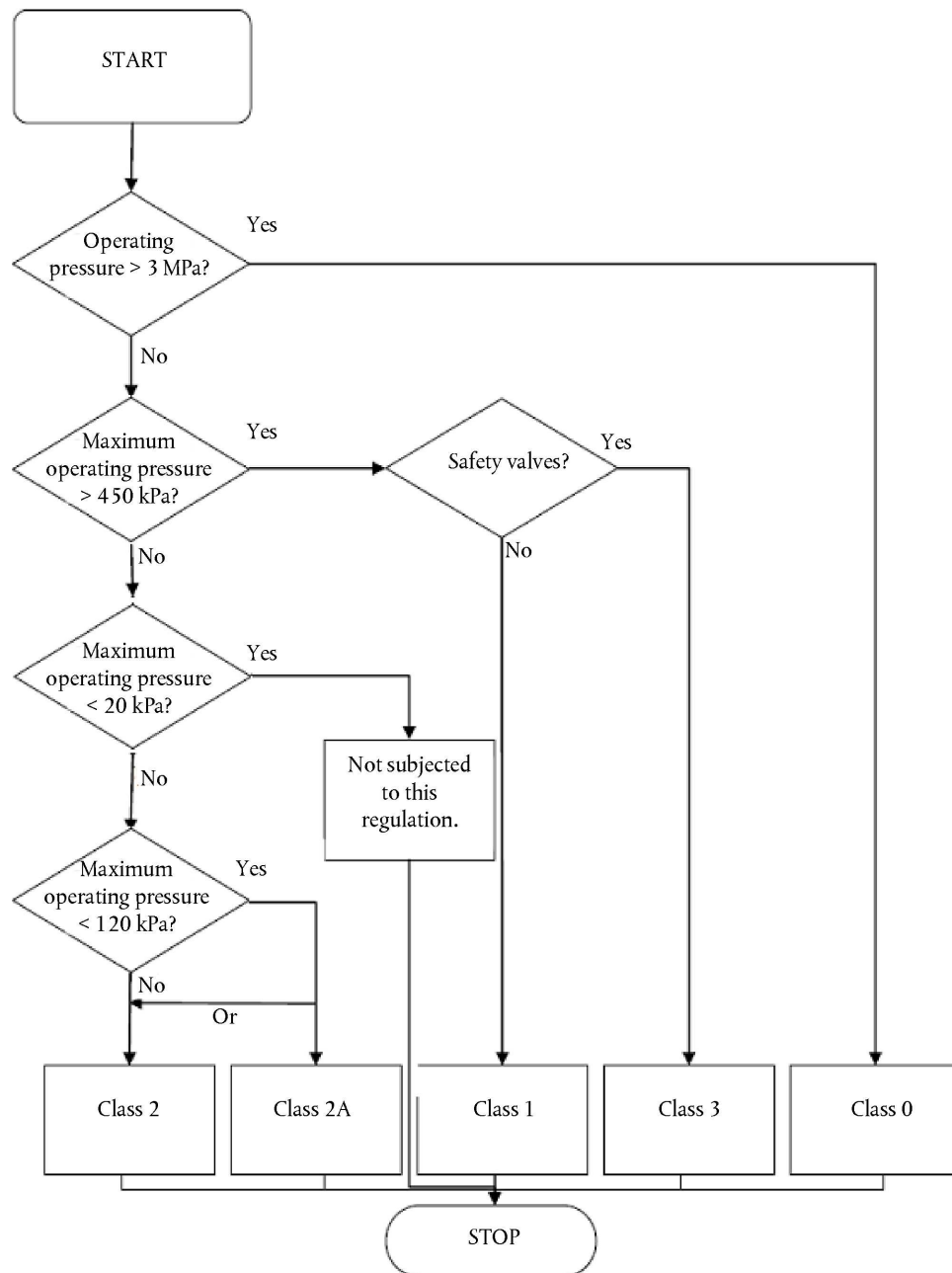

For the purposes of this Regulation:

- 2.1. 'Pressure' means relative pressure versus atmospheric pressure, unless otherwise stated.
- 2.1.1. 'Service pressure' means the settled pressure at a uniform gas temperature of 15 °C.
- 2.1.2. 'Test pressure' means the pressure to which the component is subjected during the approval test.
- 2.1.3. 'Working pressure (WP)' means the maximum pressure to which the component is designed to be subjected and on the basis of which its strength is determined.
- 2.1.4. 'Operating pressure' means the pressure under normal operating conditions.
- 2.1.5. 'Maximum operating pressure' means the maximum pressure in a component which might arise during operation.

- 2.1.6. 'Classification pressure' means the maximum allowable operating pressure in a component according to its classification.
- 2.2. 'Specific equipment' means:
- (a) The container;
  - (b) The accessories fitted to the container;
  - (c) The vapouriser/pressure regulator;
  - (d) The shut-off valve;
  - (e) The gas injection device or injector or gas mixing piece;
  - (f) The gas dosage unit either separate or combined with the gas injection device;
  - (g) Flexible hoses;
  - (h) Filling unit;
  - (i) Non-return valve;
  - (j) Gas-tube pressure relief valve;
  - (k) Filter unit;
  - (l) Pressure or temperature sensor;
  - (m) Fuel pump;
  - (n) Service coupling;
  - (o) Electronic control unit;
  - (p) Fuel rail;
  - (q) Pressure relief device;
  - (r) Multi-component.
- 2.3. 'Container' means any vessel used for the storage of liquefied petroleum gas.
- 2.3.1. A container can be:
- (a) A standard cylindrical container with a cylindrical shell, two dished ends either torispherical or elliptical and the required openings;
  - (b) A special container: other containers than standard cylindrical containers. The dimensional characteristics are given in Annex 10, Appendix 5.
- 2.3.2. 'All-composite container' means a container made only of composite materials with a non-metallic liner.
- 2.3.3. 'Batch of containers' means a maximum of 200 containers of the same type produced consecutively on the same production line.
- 2.4. 'Type of container' means containers which do not differ in respect to the following characteristics as specified in Annex 10:
- (a) The trade name(s) or trade mark(s);
  - (b) The shape (cylindrical, special shape);
  - (c) The openings (plate for accessories/metal ring);
  - (d) The material;
  - (e) The welding process (in case of metal containers);

- (f) The heat treatment (in case of metal containers);
  - (g) The production line;
  - (h) The nominal wall thickness;
  - (i) The diameter;
  - (j) The height (in case of special containers).
- 2.5. 'Accessories fitted to the container' means the following equipment which may be either separate or combined:
- (a) 80 per cent stop valve;
  - (b) Level indicator;
  - (c) Pressure relief valve;
  - (d) Remotely controlled service valve with excess flow valve;
  - (e) Fuel pump;
  - (f) Multivalve;
  - (g) Gas-tight housing;
  - (h) Power supply bushing;
  - (i) Non-return valve;
  - (j) Pressure relief device.
- 2.5.1. '80 per cent stop valve' means a device that limits the filling at maximum 80 per cent of the capacity of the container.
- 2.5.2. 'Level indicator' means a device to verify the level of liquid in the container.
- 2.5.3. 'Pressure relief valve (discharge valve)' means a device to limit the pressure build-up in the container.
- 2.5.3.1. 'Pressure relief device' means a device aimed to protect the container from burst which can occur in case of fire, by venting the LPG contained.
- 2.5.4. 'Remotely controlled service valve with excess flow valve' means a device which allows the establishment and interruption of LPG supply to the evaporator/pressure regulator; remotely controlled means that the service valve is controlled by the electronic control unit; when the engine of the vehicle is not running the valve is closed; an excess flow valve means a device to limit the flow of LPG.
- 2.5.5. 'Fuel pump' means a device to establish the supply of liquid LPG to the engine by increasing the pressure of the container with the fuel pump supply pressure.
- 2.5.6. 'Multivalve' means a device consisting of all or part of the accessories mentioned in paragraphs 2.5.1 to 2.5.3 and 2.5.8.
- 2.5.7. 'Gas-tight housing' means a device to protect the accessories and to vent any leakages to the open air.
- 2.5.8. Power supply bushing (fuel pump/actuators/fuel level sensor).
- 2.5.9. 'Non-return valve' means a device to allow the flow of liquid LPG in one direction and to prevent the flow of liquid LPG in the opposite direction.
- 2.6. 'Vaporiser' means a device intended to vaporise LPG from a liquid to a gaseous state.
- 2.7. 'Pressure regulator' means a device intended for reducing and regulating the pressure of liquefied petroleum gas.
- 2.8. 'Shut-off valve' means a device to cut off the flow of LPG.



- 2.9. 'Gas-tube pressure relief valve' means a device to prevent the pressure build up in the tubes above a pre-set value.
- 2.10. 'Gas injection device or injector or gas mixing piece' means a device which establishes the liquid or vaporised LPG to enter the engine.
- 2.11. 'Gas dosage unit' means a device which meters and/or distributes the gas flow to the engine and can be either combined with the gas injection device or separate.
- 2.12. 'Electronic control unit' means a device which controls the LPG demand of the engine and cuts off automatically the power to the shut-off valves of the LPG system in case of a broken fuel supply pipe caused by an accident, or by stalling of the engine.
- 2.13. 'Pressure or temperature sensor' means a device which measures pressure or temperature.
- 2.14. 'LPG filter unit' means a device which filters the LPG, the filter can be integrated in other components.
- 2.15. 'Flexible hoses' means hoses for conveying liquefied petroleum gas in either a liquid or vapour state at various pressures from one point to another.
- 2.16. 'Filling unit' means a device to allow filling of the container; the filling unit can be realised by integration in the 80 per cent stop valve of the container or by a remote filling unit at the outside of the vehicle.
- 2.17. 'Service coupling' means a coupling in the fuel line between the fuel container and the engine. If a mono-fuel vehicle is out of fuel the engine can be operated by means of a service fuel container which can be coupled to the service coupling.
- 2.18. 'Fuel rail' means a pipe or duct that connects the fuel injection devices.
- 2.19. 'Liquefied petroleum gas (LPG)' means any product essentially composed of the following hydrocarbons:  
Propane, propene (propylene), normal butane, isobutane, isobutylene, butene (butylene) and ethane.  
European Standard EN 589:1993 specifies requirements and methods of test for automotive LPG as marketed and delivered in the countries of the members of CEN (European Committee for Standardisation).
- 2.20. 'Hose assembly' means an assembly of a flexible hose and couplings.

## PART I

## APPROVAL OF SPECIFIC EQUIPMENT OF VEHICLES OF CATEGORIES M AND N USING LIQUEFIED PETROLEUM GASES IN THEIR PROPULSION SYSTEM

3. APPLICATION FOR APPROVAL
- 3.1. The application for approval of specific equipment shall be submitted by the holder of the trade name or mark or by his duly accredited representative.
- 3.2. It shall be accompanied by the under mentioned documents in triplicate and by the following particulars:
- 3.2.1. A detailed description of the type of the specific equipment (as specified in Annex 1),
- 3.2.2. A drawing of the specific equipment, sufficiently detailed and on an appropriate scale,
- 3.2.3. Verification of compliance with the specifications prescribed in paragraph 6 of this Regulation.
- 3.3. At the request of the Technical Service responsible for conducting approval tests, samples of the specific equipment shall be provided.

Supplementary samples shall be supplied upon request.

4. MARKINGS
- 4.1. All components submitted for approval shall bear the trade name or mark of the manufacturer and the type; and for non-metallic components also the manufacturing month and year; this marking shall be clearly legible and indelible.
- 4.2. All equipment shall have a space large enough to accommodate the approval mark including the classification of the component (see Annex 2A) and in case of components of Class 0 also the working pressure (WP); this space shall be shown on the drawings referred to in paragraph 3.2.2 above.
- 4.3. Every container shall also bear a marking plate, welded to it, with the following data clearly legible and indelible:
- (a) A serial number;
  - (b) The capacity in litres;
  - (c) The marking 'LPG';
  - (d) Test pressure [kPa];
  - (e) The wording: 'maximum degree of filling: 80 %';
  - (f) Year and month of approval (e.g. 99/01);
  - (g) Approval mark according to paragraph 5.4;
  - (h) The marking 'PUMP INSIDE' and a marking identifying the pump when a pump is mounted in the container.
- 4.4. In addition to provisions of paragraphs 4.1 and 4.2, one of the following additional marks shall be used for remotely controlled service valves and remotely controlled shut-off valves which comply respectively with paragraph 4.7 of Annex 3 or with paragraph 1.7 of Annex 7:
- (a) 'H<sub>1</sub>'
  - (b) 'H<sub>2</sub>'
  - (c) 'H<sub>3</sub>'
5. APPROVAL
- 5.1. If the equipment samples submitted for approval meet the requirements of paragraphs 6.1 to 6.13 of this Regulation, approval of the type of equipment shall be granted.
- 5.2. An approval number shall be assigned to each type of equipment approved. Its first two digits (at present 01 corresponding to the 01 series of amendments which entered into force on 13 November 1999) shall indicate the series of amendments incorporating the most recent major technical amendments made to the Regulation at the time of issue of the approval. The same Contracting Party shall not assign this alphanumeric code to another type of equipment.
- 5.3. Notice of approval or of refusal or of extension of approval of an LPG equipment type/part pursuant to this Regulation shall be communicated to the Parties to the Agreement applying this Regulation, by means of a form conforming to the model in Annex 2B to this Regulation. If it concerns a container, Annex 2B — Appendix shall be added.
- 5.4. There shall be affixed, conspicuously and in the space referred to in paragraph 4.2 above, to all equipment conforming to a type approved under this Regulation, in addition to the mark prescribed in paragraphs 4.1 and 4.3 above, an international approval mark consisting of:
- 5.4.1. A circle surrounding the letter 'E' followed by the distinguishing number of the country which has granted approval <sup>(1)</sup>.

<sup>(1)</sup> The distinguishing numbers of the Contracting Parties to the 1958 Agreement are reproduced in Annex 3 to the Consolidated Resolution on the Construction of Vehicles (R.E.3), document ECE/TRANS/WP.29/78/Rev. 3 — [www.unece.org/trans/main/wp29/wp29wgs/wp29gen/wp29resolutions.html](http://www.unece.org/trans/main/wp29/wp29wgs/wp29gen/wp29resolutions.html)

5.4.2. The number of this Regulation, followed by the letter 'R', a dash and the approval number to the right of the circle prescribed in paragraph 5.4.1 above. This approval number consists of the component type approval number which appears on the certificate completed for this type (see paragraph 5.2 above and Annex 2B) preceded by two figures indicating the sequence of the latest series of amendments to this Regulation.

5.5. The approval mark shall be clearly legible and be indelible.

5.6. Annex 2A to this Regulation gives examples of the arrangement of the aforesaid approval mark.

5.7. In case of a Class 0 component also the working pressure shall be marked in the vicinity of the approval mark mentioned in paragraph 5.4 above.

## 6. SPECIFICATIONS REGARDING THE VARIOUS COMPONENTS OF THE LPG EQUIPMENT

### 6.1. General provisions

The specific equipment of vehicles using LPG in their propulsion system shall function in a correct and safe way.

The materials of the equipment which are in contact with LPG shall be compatible with it.

Those parts of equipment whose correct and safe functioning is liable to be influenced by LPG, high pressure or vibrations has to be submitted to relevant test procedures described in the annexes to this Regulation. In particular the provisions of paragraphs 6.2 to 6.13 below are to be fulfilled.

The installation of LPG equipment approved by this Regulation shall comply with relevant electromagnetic compatibility (EMC) requirements according to Regulation No 10, 02 series of amendments, or equivalent.

### 6.2. Provisions regarding containers

The LPG containers shall be type approved pursuant to the provisions laid down in Annex 10 to this Regulation.

### 6.3. Provisions regarding accessories fitted to the container

6.3.1. The container shall be equipped with the following accessories, which may be either separate or combined (multivalve(s)):

6.3.1.1. 80 per cent stop valve;

6.3.1.2. Level indicator;

6.3.1.3. Pressure relief valve (discharge valve);

6.3.1.4. Remotely controlled service valve with excess flow valve.

6.3.2. The container may be equipped with a gas-tight housing, if necessary.

6.3.3. The container may be equipped with a power supply bushing for the sake of actuators/LPG fuel pump.

6.3.4. The container may be equipped with a LPG fuel pump inside the container.

6.3.5. The container may be equipped with a non-return valve.

6.3.6. The container shall be equipped with a pressure relief device (PRD). Devices or functions may be approved as PRD being:

(a) A fusible plug (temperature triggered) (fuse), or

- (b) A pressure relief valve provided that it complies to paragraph 6.15.8.3 below, or
- (c) A combination of the two above devices, or
- (d) Any other equivalent technical solution provided that it ensures the same degree of performance.

6.3.7. The accessories mentioned in paragraphs 6.3.1 to 6.3.6 above shall be type approved pursuant to the provisions laid down in:

- (a) Annex 3 to this Regulation for accessories mentioned in paragraphs 6.3.1, 6.3.2, 6.3.3 and 6.3.6 above;
- (b) Annex 4 to this Regulation for accessories mentioned in paragraph 6.3.4 above;
- (c) Annex 7 to this Regulation for accessories mentioned in paragraph 6.3.5 above.

6.4. - 6.14. Provisions regarding other components

The other components, which are shown in Table 1, shall be type approved pursuant to the provisions laid down in the annexes which can be determined from the table.

Table 1

Paragraph	Component	Annex
6.4.	Fuel pump	4
6.5.	Vaporiser <sup>(1)</sup> Pressure regulator <sup>(1)</sup>	6
6.6.	Shut-off valves Non-return valves Gas-tube pressure relief valves Service couplings	7
6.7.	Flexible hoses	8
6.8.	Filling unit	9
6.9.	Gas injection devices/Gas mixing piece <sup>(3)</sup> or Injectors	11
6.10.	Gas dosage units <sup>(2)</sup>	12
6.11.	Pressure sensors Temperature sensors	13
6.12.	Electronic control unit	14
6.13.	LPG filter units	5
6.14.	Pressure relief device	3

<sup>(1)</sup> Either combined or separate

<sup>(2)</sup> Only applicable when the gas dosage actuator is not integrated in the gas injection device.

<sup>(3)</sup> Applicable only when the operating pressure of the gas mixing piece exceeds 20 kPa (Class 2).

- 6.15. General design rules regarding components
- 6.15.1. Provisions regarding the 80 per cent stop valve
- 6.15.1.1. The connection between the float and the closing unit of the 80 per cent stop valve shall not be deformed under normal conditions of use.
- 6.15.1.2. If the 80 per cent stop valve of the container comprises a float, the latter shall withstand an outside pressure of 4 500 kPa.
- 6.15.1.3. The closing unit of the device that limits the filling at 80 per cent + 0/- 5 per cent of the capacity of the container, for which the 80 per cent stop valve is designed, shall withstand a pressure of 6 750 kPa. At the cut-off position, the filling rate at a differential pressure of 700 kPa shall not exceed 500 cm<sup>3</sup>/minute. The valve shall be tested with all the containers on which it is intended to be fitted or the manufacturer shall declare by calculation for which container types this valve is suitable.
- 6.15.1.4. When the 80 per cent stop valve does not comprise any float, it shall not be possible to continue filling, after closing-off, at a rate exceeding 500 cm<sup>3</sup>/minute.
- 6.15.1.5. The device shall bear a permanent marking, indicating the container-type for which it has been designed, diameter and angle, and if applicable mounting indication.
- 6.15.2. Electrical operated devices containing LPG shall, in order to prevent in case of fracture of the component electric sparks on the surface of fracture:
- (a) Be insulated in a manner that no current is lead through LPG containing parts;
  - (b) Have the electrical system of the device isolated:
    - (i) From the body;
    - (ii) From the container for the fuel pump.
- Isolation resistance shall be > 10 MΩ.
- 6.15.2.1. The electrical connections inside the boot and passengers compartment shall comply with protection degree class IP 40 according to IEC Standard 60529-1989+A1:1999.
- 6.15.2.2. All other electrical connections shall comply with protection degree class IP 54 according to IEC Standard 60529-1989+A1:1999.
- 6.15.2.3. The power supply bushing (fuel pump/actuators/fuel level sensor) to establish an isolated and tight electrical connection shall be of a hermetic sealed type.
- 6.15.3. Specific provisions on valves activated by an electric/external (hydraulic, pneumatic) power
- 6.15.3.1. In the case of valves activated by an electric/external power (e.g. 80 per cent stop valve, service valve, shut-off valves, non-return valves, gas tube pressure relief valve, service coupling), those valves shall be in 'closed' position when their power is switched off.
- 6.15.3.2. The power of the fuel pump shall be switched off when the electronic control unit becomes defective or loses power.
- 6.15.4. Heat exchange medium (compatibility and pressure requirements)
- 6.15.4.1. The materials constituting a device which are in contact with the heat exchange medium of a device when operating shall be compatible with that fluid and shall be designed to withstand a pressure of 200 kPa of the heat exchange medium. The material shall meet the prescriptions laid down in Annex 15, paragraph 17.

6.15.4.2. The compartment containing the heat exchange medium of the vaporiser/pressure regulator shall be leak proof at a pressure of 200 kPa.

6.15.5. A component consisting of both high pressure and low pressure parts shall be so designed to prevent a pressure build up in the low pressure part above 2,25 times the maximum working pressure for which it has been tested. Components connected directly to the tank pressure shall be designed for the classification pressure of 3 000 kPa. Venting to the motor compartment or outside of the vehicle is not allowed.

6.15.6. Specific provisions to prevent any gas flow

6.15.6.1. Pumps of Class 1 shall be so designed that the outlet pressure never exceeds 3 000 kPa, when there is e.g. blocking of the tubing or not opening of a shut-off valve. This can be realised by switching off the pump or by recirculating to the container.

Pumps of Class 0 shall be so designed that the outlet pressure never exceeds the WP of the components downstream of the pump, when there is, e.g. blocking of the tubing or not opening of a shut-off valve. This can be realised by switching off the pump or by recirculation to the container.

6.15.6.2. The pressure regulator/vaporiser shall be so designed as to prevent any gas flow when the regulator/vaporiser unit is supplied with LPG at a pressure  $\leq 4\,500$  kPa when the regulator is not operating.

6.15.7. Provisions regarding the gas tube relief valve

6.15.7.1. Gas-tube pressure relief valves of Class 1 shall be so designed as to open at a pressure of  $3\,200 \pm 100$  kPa.

Gas-tube pressure relief valves of Class 0 shall be so designed as to open at a pressure of 1,07 WP of the pipe  $\pm 100$  kPa (if needed).

6.15.7.2. Gas-tube pressure relief valves of Class 1 shall not have internal leakage up to 3 000 kPa.

Gas-tube pressure relief valves of Class 0 shall not have internal leakage up to WP of the pipe.

6.15.8. Provisions regarding the pressure relief valve (discharge valve)

6.15.8.1. The pressure relief valve shall be mounted inside the container or on the container, in the area where the fuel is in gaseous state.

6.15.8.2. The pressure relief valve shall be so designed as to open at a pressure of  $2\,700 \pm 100$  kPa.

6.15.8.3. The flow capacity of the pressure relief valve, determined with compressed air at a pressure which is 20 per cent higher than the normal operating-pressure shall be at least

$$Q \geq 10,66 \times A^{0,82}$$

In which:

Q = flow of air in standard m<sup>3</sup>/min. (100 kPa absolute and temperature of 15 °C)

A = exterior surface of the container in m<sup>2</sup>.

The flow test results shall be corrected to standard conditions:

Air pressure of 100 kPa absolute and temperature of 15 °C.

When the pressure relief valve is considered as a pressure relief device, the flow shall be at least 17,7 standard m<sup>3</sup>/min.

- 6.15.8.4. The pressure relief valve shall not have internal leakage up to 2 600 kPa.
- 6.15.8.5. The pressure relief device (fuse) shall be designed to open at a temperature of  $120 \pm 10$  °C.
- 6.15.8.6. The pressure relief device (fuse) shall be designed to have, when opened, a flow capacity of:
- $$Q \geq 2,73 \times A$$
- In which:
- Q = flow of air in standard m<sup>3</sup>/min. (100 kPa absolute and temperature of 15 °C)
- A = exterior surface of the container in m<sup>2</sup>.
- The flow test shall be carried out at an upstream air pressure of 200 kPa absolute, and at temperature of 15 °C.
- The flow test results shall be corrected to standard conditions:
- Air pressure of 100 kPa absolute, and temperature of 15 °C.
- 6.15.8.7. The pressure relief device shall be mounted on the container in the gaseous zone.
- 6.15.8.8. The pressure relief device shall be fitted to the container in such a manner that it can discharge into the gas tight housing, when its presence is prescribed.
- 6.15.8.9. The pressure relief device (fuse) shall be tested according to the provisions described in Annex 3, paragraph 7.
- 6.15.9. Power dissipation of the fuel pump
- At minimum fuel level whereby the engine is still operating the heat build-up by the fuel pump(s) should never cause the pressure relief valve to open.
- 6.15.10. Provisions regarding the filling unit
- 6.15.10.1. The filling unit shall be equipped with at least one soft-seated non-return valve, and it shall not be dismountable by design.
- 6.15.10.2. The filling unit shall be protected against contamination.
- 6.15.10.3. The design and dimensions of the connecting area of the filling unit shall comply with those in the figures in Annex 9.
- The filling unit shown in Figure 5 is only applicable for motor vehicles of categories M<sub>2</sub>, M<sub>3</sub>, N<sub>2</sub>, N<sub>3</sub> and M<sub>1</sub> having a maximum total mass > 3 500 kg.
- 6.15.10.4. The filling unit shown in Figure 4 may also apply for motor vehicles of categories M<sub>2</sub>, M<sub>3</sub>, N<sub>2</sub>, N<sub>3</sub> and M<sub>1</sub> having a maximum total mass > 3 500 kg <sup>(1)</sup>.
- 6.15.10.5. The outside filling unit is connected to the container by a hose or pipe.
- 6.15.10.6. Specific provisions regarding the light vehicle Euro filling unit (Annex 9 — Figure 3):
- 6.15.10.6.1. The dead volume between the front sealing surface and the front of the non-return valve shall not exceed 0,1 cm<sup>3</sup>;

<sup>(1)</sup> As defined in the Consolidated Resolution on the Construction of Vehicles (R.E.3.), document ECE/TRANS/WP.29/78/Rev.3, para. 2.

- 6.15.10.6.2. The flow through the connector at a pressure difference of 30 kPa shall be at least 60 litres/min., if tested with water.
- 6.15.10.7. Specific provisions regarding the heavy-duty vehicle Euro filling unit (Annex 9 — Figure 5):
- 6.15.10.7.1. The dead volume between the front sealing surface and the front of the non-return valve shall not exceed 0,5 cm<sup>3</sup>;
- 6.15.10.7.2. The flow through the filling unit, with the non-return valve mechanically opened, at a pressure difference of 50 kPa shall be at least 200 litres/min., when tested with water.
- 6.15.10.7.3. The Euro filling unit shall comply with the impact test as described in Annex 9, paragraph 7.4.
- 6.15.11. Provisions regarding the level indicator
- 6.15.11.1. The device to verify the level of liquid in the container shall be of an indirect type (for example magnetic) between the inside and outside of the container. If the device to verify the level of liquid in the container is of a direct type, the electric power connections should meet IP54 specifications according to IEC EN 60529:1997-06.
- 6.15.11.2. If the level indicator of the container comprises a float, the latter shall withstand an outside pressure of 3 000 kPa.
- 6.15.12. Provisions regarding the gas tight housing of the container.
- 6.15.12.1. The gas-tight housing outlet shall have a total free cross-section of at least 450 mm<sup>2</sup>.
- 6.15.12.2. The gas-tight housing shall be leak-proof at a pressure of 10 kPa with the aperture(s) closed off, maximum allowed leak rate of 100 cm<sup>3</sup>/h vapour and show no permanent deformation.
- 6.15.12.3. The gas-tight housing shall be designed to withstand a pressure of 50 kPa.
- 6.15.13. Provisions regarding the remotely controlled service valve with excess flow valve.
- 6.15.13.1. Provisions regarding the service valve
- 6.15.13.1.1. In case of the service valve is combined with a LPG fuel supply pump, identification of the pump shall be realised by the marking 'PUMP INSIDE' and the identification of the pump either on the marking plate of the LPG container or on the multivalve if present. Electrical connections inside the LPG container shall comply with protection degree class IP 40 according to IEC Standard 60529-1989+A1:1999.
- 6.15.13.1.2. Service valves of Class 1 shall withstand a pressure of 6 750 kPa in the open and closed position. Service valves of Class 0 shall withstand a pressure of 2,25 WP in the open and closed position.
- 6.15.13.1.3. The service valve shall not, at the shut-off position, allow an internal leak rate in the flow direction. There may be leak in the back flow direction.
- 6.15.13.2. Provisions regarding the excess flow valve
- 6.15.13.2.1. The excess flow valve shall be mounted inside the container.
- 6.15.13.2.2. The excess flow valve shall be designed with a bypass to allow for equalisation of pressures.



6.15.13.2.3. The excess flow valve shall cut off at a pressure difference over the valve of 90 kPa. At this pressure difference the flow shall not exceed 8 000 cm<sup>3</sup>/min.

6.15.13.2.4. When the excess flow valve is at cut-off position, the flow through the by-pass shall not exceed 500 cm<sup>3</sup>/min. at a differential pressure of 700 kPa.

## 7. MODIFICATIONS OF A TYPE OF LPG EQUIPMENT AND EXTENSION OF APPROVAL

7.1. Every modification of a type of LPG equipment shall be notified to the Type Approval Authority which granted the type approval. The Type Approval Authority may then either:

7.1.1. Consider that the modifications made are unlikely to have an appreciable adverse effect, and that the equipment still complies with the requirements; or

7.1.2. Consider whether retesting will be partial or complete.

7.2. Confirmation or refusal of approval, specifying the alterations, shall be communicated by the procedure specified in paragraph 5.3 above to the Parties to the Agreement which apply this Regulation.

7.3. The Type Approval Authority issuing the extension of approval shall assign a series number to each communication form drawn up for such an extension.

8. (NOT ALLOCATED)

## 9. CONFORMITY OF PRODUCTION

The conformity of production procedures shall comply with those set out in the Agreement, Appendix 2 (E/ECE/324-E/ECE/TRANS/505/Rev.2), with the following requirements:

9.1. All equipment approved under this Regulation shall be so manufactured as to conform to the type approved by meeting the requirements of paragraph 6 above.

9.2. In order to verify that the requirements of paragraph 9.1 are met, suitable controls of production shall be carried out.

9.3. The minimum requirements for conformity of production control tests set forth in Annexes 8, 10 and 15 to this Regulation shall be complied with.

9.4. The Type Approval Authority which has granted type approval may at any time verify the conformity control methods applied in each production facility. The normal frequency of these verifications shall be once every year.

9.5. Moreover, each container shall be tested at a minimum pressure of 3 000 kPa in conformity with the prescriptions of paragraph 2.3 of Annex 10 to this Regulation.

9.6. Every hose assembly which is applied in the high pressure class (Class 1) according to the classification as prescribed in paragraph 2 of this Regulation, shall, during half a minute, be subjected to a test with gas under a pressure of 3 000 kPa by the approval holder.

9.6.1. Every hose assembly which is applied in the high pressure class (Class 0) according to the classification as prescribed in paragraph 2 of this Regulation, shall, during half a minute, be subjected to a test with gas under a pressure of the declared WP by the approval holder.

9.7. For welded containers at least 1 per 200 containers and one of the remaining number has to be subjected to the radiographic examination according to Annex 10, paragraph 2.4.1.

9.8. During production 1 of 200 containers and 1 of the remaining number has to be subjected to the abovementioned mechanical tests as described in Annex 10, paragraph 2.1.2.

#### 10. PENALTIES FOR NON-CONFORMITY OF PRODUCTION

10.1. The approval granted in respect of a type of equipment pursuant to this Regulation may be withdrawn if the requirements laid down in paragraph 9 above are not complied with.

10.2. If a Party to the Agreement applying this Regulation withdraws an approval it has previously granted, it shall forthwith so notify the other Contracting Parties applying this Regulation, by means of a communication form conforming to the model in Annex 2B to this Regulation.

#### 11. TRANSITIONAL PROVISIONS REGARDING THE VARIOUS COMPONENTS OF THE LPG EQUIPMENT

11.1. As from the official date of entry into force of the 01 series of amendments to this Regulation, no Contracting Party applying this Regulation shall refuse to grant approval under this Regulation as amended by the 01 series of amendments.

11.2. As from 3 months after the official date of entry into force of the 01 series of amendments to this Regulation, Contracting Parties applying this Regulation shall grant approvals only if the type of component to be approved meets the requirements of this Regulation as amended by the 01 series of amendments.

11.3. No Contracting Party applying this Regulation shall refuse a type of component approved to the 01 series of amendments to this Regulation.

11.4. Until 12 months after the date of entry into force of the 01 series of amendments to this Regulation, no Contracting Party applying this Regulation shall refuse a type of component approved to this Regulation in its original form.

11.5. Upon the expiration of a period of 12 months after the date of entry into force of the 01 series of amendments, Contracting Parties applying this Regulation may refuse the sale of a type of component which does not meet the requirements of the 01 series of amendments to this Regulation, unless the component is intended as a replacement for fitting on vehicles in use.

#### 12. PRODUCTION DEFINITELY DISCONTINUED

If the holder of the approval completely ceases to manufacture a type of equipment approved in accordance with this Regulation, he shall so inform the Type Approval Authority which granted the approval. Upon receiving the relevant communication, that Authority shall inform thereof the other Contracting Parties to the Agreement applying this Regulation by means of a communication form conforming to the model in Annex 2B to this Regulation.

#### 13. NAMES AND ADDRESSES OF TECHNICAL SERVICES RESPONSIBLE FOR CONDUCTING APPROVAL TESTS, AND OF TYPE APPROVAL AUTHORITIES

The Contracting Parties to the Agreement applying this Regulation shall communicate to the United Nations Secretariat the names and addresses of the Technical Services responsible for conducting approval tests and of the Type Approval Authorities which grant approval and to which forms certifying approval or extension or refusal or withdrawal of approval, issued in other countries, are to be sent.

## PART II

## APPROVAL OF VEHICLES OF CATEGORIES M AND N FITTED WITH SPECIFIC EQUIPMENT FOR THE USE OF LIQUEFIED PETROLEUM GASES IN THEIR PROPULSION SYSTEM WITH REGARD TO THE INSTALLATION OF SUCH EQUIPMENT

14. DEFINITIONS
- 14.1. For the purposes of Part II of this Regulation:
- 14.1.1. 'Approval of a vehicle' means the approval of a vehicle type with regard to the installation of its specific equipment for the use of liquefied petroleum gases in its propulsion system;
- 14.1.2. 'Vehicle type' means a vehicle or a family of vehicles fitted with specific equipment for the use of LPG in its propulsion system, which do not differ with respect to the following conditions:
- 14.1.2.1. The manufacturer;
- 14.1.2.2. The type designation established by the manufacturer;
- 14.1.2.3. The essential aspects of design and construction;
- 14.1.2.3.1. Chassis/floor pan (obvious and fundamental differences);
- 14.1.2.3.2. Installation of the LPG equipment (obvious and fundamental differences).
- 14.1.3. 'Commanded stop phase' defines the period of time during which the combustion engine is switched off automatically for fuel saving and is allowed to start again automatically.
15. APPLICATION FOR APPROVAL
- 15.1. The application for approval of a vehicle type with regard to the installation of specific equipment for the use of liquefied petroleum gases in its propulsion system shall be submitted by the vehicle manufacturer or by his duly accredited representative.
- 15.2. It shall be accompanied by the undermentioned documents in triplicate: description of the vehicle comprising all the relevant particulars referred to in Annex 1 to this Regulation.
- 15.3. A vehicle representative of the vehicle type to be approved shall be submitted to the Technical Service conducting the approval tests.
16. APPROVAL
- 16.1. If the vehicle submitted for approval pursuant to this Regulation is provided with all the necessary specific equipment for the use of liquefied petroleum gases in its propulsion system and meets the requirements of paragraph 17 below, approval of that vehicle type shall be granted.
- 16.2. An approval number shall be assigned to each type of vehicle approved. Its first two digits shall indicate the series of amendments incorporating the most recent major technical amendments made to the Regulation at the time of issue of the approval.
- 16.3. Notice of approval or of refusal or of extension of approval of an LPG vehicle type pursuant to this Regulation shall be communicated to the Parties to the Agreement applying this Regulation, by means of a form conforming to the model in Annex 2D to this Regulation.
- 16.4. There shall be affixed, conspicuously and in a readily accessible space specified on the approval form referred to in paragraph 16.3 above, to every vehicle type approved under this Regulation an international approval mark consisting of:
- 16.4.1. A circle surrounding the letter 'E' followed by the distinguishing number of the country which has granted approval <sup>(1)</sup>.

<sup>(1)</sup> The distinguishing numbers of the Contracting Parties to the 1958 Agreement are reproduced in Annex 3 to the Consolidated Resolution on the Construction of Vehicles (R.E.3), document ECE/TRANS/WP.29/78/Rev.3

- 16.4.2. The number of this Regulation, followed by the letter 'R', a dash and the approval number to the right of the circle prescribed in paragraph 16.4.1 above.
- 16.5. If the vehicle conforms to a vehicle approved, under one or more other Regulations annexed to the Agreement, in the country which has granted approval under this Regulation, the symbol prescribed in paragraph 16.4.1 above need not be repeated; in such case, the Regulation and approval numbers and the additional symbols of all the Regulations under which approval has been granted in the country which has granted approval under this Regulation shall be placed in vertical columns to the right of the symbol prescribed in paragraph 16.4.1 above.
- 16.6. The approval mark shall be clearly legible and be indelible.
- 16.7. The approval mark shall be placed close to or on the vehicle data plate.
- 16.8. Annex 2C to this Regulation gives examples of the arrangement of the aforesaid approval mark.
17. REQUIREMENTS FOR THE INSTALLATION OF SPECIFIC EQUIPMENT FOR THE USE OF LIQUEFIED PETROLEUM GASES IN THE PROPULSION SYSTEM OF A VEHICLE
- 17.1. General
- 17.1.1. The LPG equipment as installed in the vehicle shall function in such a manner that the working pressure for which it has been designed and approved cannot be exceeded.
- 17.1.2. All parts of the system shall be type approved for individual parts pursuant to Part I of this Regulation.
- 17.1.2.1. Notwithstanding the provisions of paragraph 17.1.2 above, if the LPG electronic control unit is integrated into the engine electronic control unit and is covered with a vehicle installation type approval according to Part II of this Regulation and to Regulation No 10, no separate type approval of the LPG electronic control unit is necessary. The vehicle type approval shall also be approved pursuant to the applicable provisions laid down in Annex 14 to this Regulation.
- 17.1.3. The materials used in the system shall be suitable for use with LPG.
- 17.1.4. All parts of the system shall be fastened in a proper way.
- 17.1.5. The LPG system shall show no leaks.
- 17.1.6. The LPG system shall be installed such that it has the best possible protection against damage, such as damage due to moving vehicle components, collision, grit or due to the loading or unloading of the vehicle or the shifting of those loads.
- 17.1.7. No appliances shall be connected to the LPG system other than those strictly required for the proper operation of the engine of the motor vehicle.
- 17.1.7.1. Notwithstanding the provisions of paragraph 17.1.7 above, motor vehicles of categories M<sub>2</sub>, M<sub>3</sub>, N<sub>2</sub>, N<sub>3</sub> and M<sub>1</sub> having either a maximum total mass > 3 500 kg or a body type SA <sup>(1)</sup> <sup>(2)</sup>, may be fitted with a heating system to heat the passenger compartment which is connected to the LPG system.
- 17.1.7.2. The heating system referred to in paragraph 17.1.7.1 above shall be permitted if, in the view of the Technical Services responsible for conducting type approval, the heating system is adequately protected and the required operation of the normal LPG system is not affected.
- 17.1.7.3. Notwithstanding the provisions of paragraph 17.1.7 above, a mono-fuel vehicle without limp-home system may be equipped with a service coupling in the LPG system.

<sup>(1)</sup> As defined in the Consolidated Resolution on the Construction of Vehicles (R.E.3.), document ECE/TRANS/WP.29/78/Rev.3, para. 2 — [www.unece.org/trans/main/wp29/wp29wgs/wp29gen/wp29resolutions.html](http://www.unece.org/trans/main/wp29/wp29wgs/wp29gen/wp29resolutions.html)

<sup>(2)</sup> As defined in the Consolidated Resolution on the Construction of Vehicles (R.E.3.), document ECE/TRANS/WP.29/78/Rev.3, para. 2.

- 17.1.7.4. The service coupling referred to in paragraph 17.1.7.3 above shall be permitted if, in the view of the Technical Services responsible for conducting type approval, the service coupling is adequately protected and the required operation of the normal LPG system is not affected. The service coupling shall be combined with a separate gas-tight non-return valve whereby it is only possible to operate the engine.
- 17.1.7.5. Mono-fuel vehicles installed with a service coupling shall carry a sticker near the service coupling as specified in Annex 17 to this Regulation.
- 17.1.8. Identification of LPG-fuelled M<sub>2</sub> and M<sub>3</sub> category vehicles.
- 17.1.8.1. Vehicles of category M<sub>2</sub> and M<sub>3</sub> shall carry a plate as specified in Annex 16 to this Regulation.
- 17.1.8.2. The plate shall be installed on the front and rear of the M<sub>2</sub> or M<sub>3</sub> category vehicle and on the outside of the doors on the left-hand side for the right hand drive vehicles and on the right-hand side for the left hand drive vehicles.
- 17.2. Further requirements
- 17.2.1. No component of the LPG system, including any protective materials which form part of such components, shall project beyond the external surface of the vehicle, with the exception of the filling unit if this does not project more than 10 mm beyond the nominal line of the body panel.
- 17.2.2. With the exception of the LPG fuel container, in no cross section of the vehicle any component of the LPG system, including any protective material which forms part of such components, may extend beyond the lower edge of the vehicle unless another part of the vehicle, within a radius of 150 mm is situated lower.
- 17.2.3. No component of the LPG system shall be located within 100 mm of the exhaust or similar heat source, unless such components are adequately shielded against heat.
- 17.3. The LPG system
- 17.3.1. An LPG system shall contain at least the following components:
- 17.3.1.1. Fuel container;
- 17.3.1.2. 80 per cent stop valve;
- 17.3.1.3. Level indicator;
- 17.3.1.4. Pressure relief valve;
- 17.3.1.5. Remotely controlled service valve with excess flow valve;
- 17.3.1.6. Pressure regulator and vaporiser, which may be combined <sup>(1)</sup>;
- 17.3.1.7. Remotely controlled shut-off valve;
- 17.3.1.8. Filling unit;
- 17.3.1.9. Gas tubes and hoses;
- 17.3.1.10. Gas-carrying connections between the LPG system components;
- 17.3.1.11. Injector or gas injection device or gas mixing piece;
- 17.3.1.12. Electronic control unit;

<sup>(1)</sup> These components might not be necessary in case of liquid LPG injection.

- 17.3.1.13. Pressure relief device (fuse).
- 17.3.2. The system may also include the following components:
- 17.3.2.1. Gas-tight housing, covering the accessories fitted to the fuel container;
- 17.3.2.2. Non-return valve;
- 17.3.2.3. Gas tube pressure relief valve;
- 17.3.2.4. Gas dosage unit;
- 17.3.2.5. LPG filter unit;
- 17.3.2.6. Pressure or temperature sensor;
- 17.3.2.7. LPG fuel pump;
- 17.3.2.8. Power supply bushing for the container (actuators/fuel pump/fuel level sensor);
- 17.3.2.9. Service coupling (mono-fuel vehicles only & no limp-home system);
- 17.3.2.10. Fuel selection system and electrical system;
- 17.3.2.11. Fuel rail.
- 17.3.3. The container fittings referred to in paragraphs 17.3.1.2 to 17.3.1.5 above may be combined.
- 17.3.4. The remotely controlled shut-off valve referred to in paragraph 17.3.1.7 above may be combined with the pressure regulator/vaporiser.
- 17.3.5. Additional components required for the effective operation of the engine may be installed in that part of the LPG system where the pressure is less than 20 kPa.
- 17.4. Installation of the fuel container
- 17.4.1. The fuel container shall be permanently installed in the vehicle and shall not be installed in the engine compartment.
- 17.4.2. The fuel container shall be installed in the correct position, according to the instructions from the container manufacturer.
- 17.4.3. The fuel container shall be installed such that there is no metal to metal contact, other than at the permanent fixing points of the container.
- 17.4.4. The fuel container shall have permanent fixing points to secure it to the motor vehicle or the container shall be secured to the motor vehicle by a container frame and container straps.
- 17.4.5. When the vehicle is ready for use the fuel container shall not be less than 200 mm above the road surface.
- 17.4.5.1. The provisions of paragraph 17.4.5 above shall not apply if the container is adequately protected, at the front and the sides and no part of the container is located lower than this protective structure.
- 17.4.6. The fuel container(s) shall be mounted and fixed so that the following accelerations can be absorbed (without damage occurring) when the containers are full:
- Vehicles of categories M<sub>1</sub> and N<sub>1</sub>:
- (a) 20 g in the direction of travel;
- (b) 8 g horizontally perpendicular to the direction of travel.

Vehicles of categories M<sub>2</sub> and N<sub>2</sub>:

- (a) 10 g in the direction of travel;
- (b) 5 g horizontally perpendicular to the direction of travel.

Vehicles of categories M<sub>3</sub> and N<sub>3</sub>:

- (a) 6,6 g in the direction of travel;
- (b) 5 g horizontally perpendicular to the direction of travel.

A calculation method can be used instead of practical testing if its equivalence can be demonstrated by the applicant for approval to the satisfaction of the Technical Service.

17.5. Further requirements to the fuel container

17.5.1. If more than one LPG container is connected to a single delivery tube each container shall be fitted with a non-return valve installed downstream of the remotely controlled service valve and a tube pressure relief valve shall be installed in the delivery tube, downstream of the non-return valve. An adequate filter system has to be placed upstream of the non-return valve(s) to prevent fouling of the non-return valve(s).

17.5.2. A non-return valve and tube pressure relief valve shall not be required if the backflow pressure of the remotely controlled service valve in the closed position exceeds 500 kPa.

In that case the control of the remotely controlled service valves shall be constructed such that it is impossible for more than one remotely controlled valve to be open at any time. The overlap time to allow switching is limited to two minutes.

17.6. Accessories to the fuel container

17.6.1. Remotely controlled service valve with excess flow valve on the container

17.6.1.1. The remotely controlled service valve with excess flow valve shall be installed directly on the fuel container, without any intervening fittings.

17.6.1.2. The remotely controlled service valve with excess flow valve shall be controlled such that it is automatically closed when the engine is not running, irrespective of the position of the ignition switch, and shall remain closed as long as the engine is not running.

17.6.1.3. Notwithstanding the provision of paragraph 17.6.1.2 above, in case of liquid injection systems, if a fuel recirculation is required to purge the system from gas bubbles (vapour lock), it is allowed to keep the remotely controlled service valve with excess flow valve open for a period not longer than 10 seconds before starting the engine in LPG running mode.

17.6.1.4. Notwithstanding the provisions of paragraph 17.6.1.2 above, the remotely controlled service valve may stay in an open position during the commanded stop phases.

17.6.1.5. If the remotely controlled service valve is closed during commanded stop phases, the valve shall comply with paragraph 4.7 of Annex 3.

17.6.2. Spring-loaded pressure relief valve in the container

17.6.2.1. The spring-loaded pressure relief valve shall be installed in the fuel container in such a manner that it is connected to the vapour space and can discharge to the surrounding atmosphere. The spring-loaded pressure relief valve may discharge into the gas-tight housing if that gas-tight housing fulfils the requirements of paragraph 17.6.5 below.

17.6.3. 80 per cent stop valve

17.6.3.1. The automatic filling level limiter shall be suitable for the fuel container it is fitted to and shall be installed in the appropriate position to ensure that the container cannot be filled to more than 80 per cent.

- 17.6.4. Level indicator
- 17.6.4.1. The level indicator shall be suitable for the fuel container it is fitted to and shall be installed in the appropriate position.
- 17.6.5. Gas-tight housing on the container
- 17.6.5.1. A gas-tight housing over the container fittings, which fulfils the requirements of paragraphs 17.6.5.2 to 17.6.5.5 below shall be fitted to the fuel container, unless the container is installed outside the vehicle and the container fittings are protected against dirt and water.
- 17.6.5.2. The gas-tight housing shall be in open connection with the atmosphere, where necessary through a connecting hose and a lead-through.
- 17.6.5.3. The ventilation opening of the gas-tight housing shall point downwards at the point of exit from the motor vehicle. However, it shall not discharge into a wheel arch, nor shall it be aimed at a heat source such as the exhaust.
- 17.6.5.4. Any connecting hose and lead-through in the bottom of the bodywork of the motor vehicle for ventilation of the gas-tight housing shall have a minimum clear opening of 450 mm<sup>2</sup>. If a gas tube, other tube or any electrical wiring is installed in the connecting hose and lead-through, the clear opening shall also be at least 450 mm<sup>2</sup>.
- 17.6.5.5. The gas-tight housing and connecting hoses shall be gas-tight at a pressure of 10 kPa with the apertures closed off, and show no permanent deformation, with a maximum allowed leak rate of 100 cm<sup>3</sup>/h.
- 17.6.5.6. The connecting hose shall be secured in a proper way to the gas-tight housing and the lead-through to ensure that a gas-tight joint is formed.
- 17.7. Gas tubes and gas hoses
- 17.7.1. Gas tubes shall be made of seamless material: either copper or stainless steel or steel with corrosion-resistant coating.
- 17.7.2. If seamless copper is used the tube shall be protected by a rubber or plastic sleeve.
- 17.7.3. The outer diameter of gas tubes made of copper shall not exceed 12 mm with a wall thickness of at least 0,8 mm, gas tubes from steel and stainless steel shall not exceed 25 mm with, for gas services, an appropriate wall thickness.
- 17.7.4. The gas tube may be made of a non-metallic material if the tube fulfils the requirements of this Regulation, paragraph 6.7.
- 17.7.5. The gas tube may be replaced by a gas hose if this hose fulfils the requirement of this Regulation, paragraph 6.7.
- 17.7.6. Gas tubes, other than non-metallic gas tubes, shall be secured such that they shall not be subjected to vibration or stresses.
- 17.7.7. Gas hoses and non-metallic gas tubes shall be secured such that they shall not be subjected to stresses.
- 17.7.8. At the fixing point the gas tube or hose shall be fitted with a protective material.
- 17.7.9. Gas tubes or hoses shall not be located at jacking points.
- 17.7.10. At passages the gas tubes or hoses, whether or not fitted with a protective sleeve, shall be fitted with protective material.



- 17.8. Gas connections between the components of the LPG system
- 17.8.1. Soldered or welded joints and bite-type compression joints are not permitted. Soldering or welding can be permitted for connecting the individual parts of detachable couplings to the gas tube or component.
- 17.8.2. Gas tubes shall only be connected by compatible fittings with regard to corrosion.
- 17.8.3. Stainless steel tubes shall only be joined by stainless steel fittings.
- 17.8.4. Distributing-blocks shall be made of corrosion-resistant material.
- 17.8.5. Gas tubes shall be connected by appropriate joints, for example, two-part compression joints in steel tubes and joints with olives tapered on both sides or two flanges in copper tubes. Gas tubes shall be connected with appropriate connections. Under no circumstances couplings may be used whereby the tube will be damaged. The burst pressure of the mounted couplings shall be the same or higher as specified for the tube.
- 17.8.6. The number of joints shall be limited to a minimum.
- 17.8.7. Any joints shall be made in locations where access is possible for inspection.
- 17.8.8. In a passenger compartment or enclosed luggage compartment the gas tube or hose shall be no longer than reasonably required; this provision is fulfilled when the gas tube or hose does not extend further than from the fuel container to the side of vehicle.
- 17.8.8.1. There shall be no gas-conveying connections in the passenger compartment or enclosed luggage compartment with the exception of:
- (a) The connections on the gas-tight housing; and
  - (b) The connection between the gas tube or hose and the filling unit if this connection is fitted with a sleeve which is resistant against LPG and any leaking gas will be discharged directly into the atmosphere.
- 17.8.8.2. The provisions of paragraph 17.8.8 and paragraph 17.8.8.1 above shall not apply for M<sub>2</sub> or M<sub>3</sub> category vehicles if the gas tubes or hoses and connections are fitted with a sleeve which is resistant against LPG and which has an open connection to the atmosphere. The open end of the sleeve or ducting shall be situated at the lowest point.
- 17.9. Remotely controlled shut-off valve
- 17.9.1. A remotely controlled shut-off valve shall be installed in the gas tube from the LPG container to the pressure regulator/vaporiser, as close as possible to the pressure regulator/vaporiser.
- 17.9.2. The remotely controlled shut-off valve may be incorporated into the pressure regulator/vaporiser.
- 17.9.3. Notwithstanding the provisions of paragraph 17.9.1 above, the remotely controlled shut-off valve may be installed at a location in the engine bay specified by the manufacturer of the LPG system if a fuel return system is provided between the pressure regulator and the LPG container.
- 17.9.4. The remotely controlled shut-off valve shall be installed such that the fuel supply is cut off when the engine is not running or, if the vehicle is also equipped with another fuel system, when the other fuel is selected. A delay of 2 seconds is permitted for diagnostic purposes.
- 17.9.5. Notwithstanding the provision of paragraph 17.9.4 above, in case of liquid injection systems, if a fuel recirculation is required to purge the system from gas bubbles (vapour lock), it is allowed to keep the remotely controlled shut-off valve open for a period not longer than 10 seconds before starting the engine in LPG running mode and during the fuel switching-over.

- 17.9.6. Notwithstanding the provisions of paragraph 17.9.4 above, the remotely controlled shut-off valve may stay in an open position during the commanded stop phases.
- 17.9.7. If the remotely controlled shut-off valve is closed during commanded stop phases, the valve shall comply with paragraph 1.7 of Annex 7.
- 17.10 Filling unit
- 17.10.1. The filling unit shall be secured against rotation and shall be protected against dirt and water.
- 17.10.2. When the LPG container is installed in the passenger compartment or an enclosed (luggage) compartment, the filling unit shall be located at the outside of the vehicle.
- 17.11. Fuel selection system and electrical installation
- 17.11.1. The electrical components of the LPG system shall be protected against overloads and at least one separate fuse shall be provided in the supply cable.
- 17.11.1.1. The fuse shall be installed in a known location where it can be reached without the use of tools.
- 17.11.2. The electrical power to LPG system components which also carry gas may not be conducted by a gas tube.
- 17.11.3. All electrical components installed in a part of the LPG system where the pressure exceeds 20 kPa shall be connected and insulated in a manner that no current is led through LPG containing parts.
- 17.11.4. Electrical cables shall be adequately protected against damage. The electrical connections inside the boot and passengers compartment shall comply with protection degree class IP 40 according to IEC Standard 60529-1989+A1:1999. All other electrical connections shall comply with protection degree class IP 54 according to IEC Standard 60529-1989+A1:1999.
- 17.11.5. Vehicles with more than one fuel system shall have a fuel selection system
- 17.11.6. The electrical connections and components in the gas-tight housing shall be constructed such that no sparks are generated.
- 17.12. Pressure relief device
- 17.12.1. The pressure relief device shall be fitted to the fuel container(s) in such a manner that it can discharge into the gas tight housing, when its presence is prescribed, if that gas tight housing fulfils the requirements of paragraph 17.6.5 above.
18. CONFORMITY OF PRODUCTION
- The conformity of production procedures shall comply with those set out in the Agreement, Appendix 2 (E/ECE/324-E/ÉCE/TRANS/505/Rev.2) with the following requirements:
- 18.1. All vehicles approved under this Regulation shall be so manufactured as to conform to the type approved by meeting the requirements of paragraph 17 above.
- 18.2. In order to verify that the requirements of paragraph 18.1 above are met, suitable controls of the production shall be carried out.
- 18.3. The Type Approval Authority which has granted type approval may at any time verify the conformity control methods applied in each production facility. The normal frequency of these verifications shall be once every year.

19. PENALTIES FOR NON-CONFORMITY OF PRODUCTION

19.1. The approval granted in respect of a type of vehicle pursuant to this Regulation may be withdrawn if the requirements laid down in paragraph 18 above are not complied with.

19.2. If a Contracting Party to the Agreement applying this Regulation withdraws an approval it has previously granted, it shall forthwith so notify the other Contracting Parties applying this Regulation, by means of a communication form conforming to the model in Annex 2D to this Regulation.

20. MODIFICATION AND EXTENSION OF APPROVAL OF A VEHICLE TYPE

20.1. Every modification of the installation of the specific equipment for the use of liquefied petroleum gases in the propulsion system of the vehicle shall be notified to the Type Approval Authority which approved the vehicle type. That Type Approval Authority may then either:

20.1.1. Consider that the modifications made are unlikely to have an appreciably adverse effect and that in any case the vehicle still complies with the requirements; or

20.1.2. Require a further test report from the Technical Service responsible for conducting the tests.

20.2. Confirmation or refusal of approval, specifying the alteration, shall be communicated by the procedure specified in paragraph 16.3 above to the Parties to the Agreement applying this Regulation.

20.3. The Type Approval Authority issuing the extension of approval shall assign a series number for such an extension and inform thereof the other Contracting Parties to the 1958 Agreement applying this Regulation by means of a communication form conforming to the model in Annex 2D to this Regulation.

21. PRODUCTION DEFINITELY DISCONTINUED

If the holder of the approval completely ceases to manufacture a type of vehicle approved in accordance with this Regulation, he shall so inform the Type Approval Authority which granted the approval. Upon receiving the relevant communication, that Authority shall inform thereof the other Contracting Parties to the Agreement applying this Regulation by means of a communication form conforming to the model in Annex 2D to this Regulation.

22. TRANSITIONAL PROVISIONS REGARDING THE INSTALLATION OF VARIOUS COMPONENTS OF THE LPG EQUIPMENT AND THE TYPE APPROVAL OF A VEHICLE FITTED WITH SPECIFIC EQUIPMENT FOR THE USE OF LIQUEFIED PETROLEUM GAS IN ITS PROPULSION SYSTEM WITH REGARD TO THE INSTALLATION OF SUCH EQUIPMENT

22.1. As from the official date of entry into force of the 01 series of amendments to this Regulation, no Contracting Party applying this Regulation shall refuse to grant approval under this Regulation as amended by the 01 series of amendments.

22.2. As from the official date of entry into force of the 01 series of amendments to this Regulation, no Contracting Party applying this Regulation shall prohibit the fitting on a vehicle and the use as first equipment of a component approved under this Regulation as amended by the 01 series of amendments.

22.3. During the period of 12 months after the date of entry into force of the 01 series of amendments to this Regulation, Contracting Parties applying this Regulation may allow the use of as first equipment of a type of component approved to this Regulation in its original form, when fitted on a vehicle transformed for LPG propulsion.

22.4. Upon the expiration of a period of 12 months after the date of entry into force of the 01 series of amendments to this Regulation, Contracting Parties applying this Regulation shall prohibit the use as first equipment of a component which does not meet the requirements of this Regulation as amended by the 01 series of amendments, when fitted on a vehicle transformed for LPG propulsion.

22.5. Upon the expiration of a period of 12 months after the date of entry into force of the 01 series of amendments to this Regulation, Contracting Parties applying this Regulation may refuse first National Registration (first entry into service) of a vehicle which does not meet the requirements of this Regulation as amended by the 01 series of amendments.

23. NAMES AND ADDRESSES OF TECHNICAL SERVICES RESPONSIBLE FOR CONDUCTING APPROVAL TESTS, AND OF TYPE APPROVAL AUTHORITIES

The Parties to the Agreement applying this Regulation shall communicate to the United Nations Secretariat the names and addresses of the Technical Services responsible for conducting approval tests and of the Type Approval Authorities which grant approval and to which forms certifying approval or extension or refusal or withdrawal of approval, issued in other countries, are to be sent.

—

## ANNEX 1

## ESSENTIAL CHARACTERISTICS OF THE VEHICLE, ENGINE AND LPG RELATED EQUIPMENT

Description of the vehicle(s)

Make: .....

Type(s): .....

Name and address of the manufacturer: .....

1. Description of the engine(s)

1.1. Manufacturer: .....

1.1.1. Manufacturer's engine code(s) (as marked on the engine or other means of identification): .....

1.2. Internal combustion engine

1.2.1.-1.2.4.4. Not used

1.2.4.5. Description of the LPG fuelling equipment:

1.2.4.5.1. System description: .....

1.2.4.5.1.1. Make(s): .....

1.2.4.5.1.2. Type(s): .....

1.2.4.5.1.3. Drawings/flow charts of the installation in the vehicle(s): .....

1.2.4.5.2. Vaporiser/pressure regulator(s):

1.2.4.5.2.1. Make(s): .....

1.2.4.5.2.2. Type(s): .....

1.2.4.5.2.3. Certification number: .....

1.2.4.5.2.4. Not used

1.2.4.5.2.5. Drawings: .....

1.2.4.5.2.6. Number of main adjustment points: .....

1.2.4.5.2.7. Description of principle of adjustment through main adjustment points: .....

1.2.4.5.2.8. Number of idle adjustment points: .....

1.2.4.5.2.9. Description of principles of adjustment through idle adjustment points: .....

1.2.4.5.2.10. Other adjustment possibilities: if so and which (description and drawings):

1.2.4.5.2.11. Operating pressure(s) <sup>(1)</sup>: ..... kPa

1.2.4.5.3. Mixing piece: yes/no <sup>(2)</sup>

1.2.4.5.3.1. Number: .....

1.2.4.5.3.2. Make(s): .....

- 1.2.4.5.3.3. Type(s): .....
- 1.2.4.5.3.4. Drawings: .....
- 1.2.4.5.3.5. Place of installation (include drawing(s)): .....
- 1.2.4.5.3.6. Adjustment possibilities: .....
- 1.2.4.5.3.7. Operating pressure(s) <sup>(1)</sup>: ..... kPa
- 1.2.4.5.4. Gas dosage unit: yes/no <sup>(2)</sup>
- 1.2.4.5.4.1. Number: .....
- 1.2.4.5.4.2. Make(s): .....
- 1.2.4.5.4.3. Type(s): .....
- 1.2.4.5.4.4. Drawings: .....
- 1.2.4.5.4.5. Place of installation (include drawing(s)): .....
- 1.2.4.5.4.6. Adjustment possibilities (description)
- 1.2.4.5.4.7. Operating pressure(s) <sup>(1)</sup>: ..... kPa
- 1.2.4.5.5. Gas injection device (s) or Injector(s): yes/no <sup>(2)</sup>
- 1.2.4.5.5.1. Make(s): .....
- 1.2.4.5.5.2. Type(s): .....
- 1.2.4.5.5.3. (Not used)
- 1.2.4.5.5.4. Operating pressure(s) <sup>(1)</sup>: ..... kPa
- 1.2.4.5.5.5. Drawings of installation: ..... kPa
- 1.2.4.5.6. Electronic Control Unit LPG-fuelling:
- 1.2.4.5.6.1. Make(s): .....
- 1.2.4.5.6.2. Type(s): .....
- 1.2.4.5.6.3. Place of installation: .....
- 1.2.4.5.6.4. Adjustment possibilities: .....
- 1.2.4.5.7. LPG container:
- 1.2.4.5.7.1. Make(s): .....
- 1.2.4.5.7.2. Type(s) (include drawings): .....
- 1.2.4.5.7.3. Number of containers: .....
- 1.2.4.5.7.4. Capacity: ..... litres
- 1.2.4.5.7.5. LPG fuel pump in container: yes/no <sup>(2)</sup>
- 1.2.4.5.7.6. (Not used)
- 1.2.4.5.7.7. Drawings of the installation of the container: .....

- 1.2.4.5.8. LPG container accessories
  - 1.2.4.5.8.1. 80 per cent stop valve:
    - 1.2.4.5.8.1.1. Make(s): .....
    - 1.2.4.5.8.1.2. Type(s): .....
    - 1.2.4.5.8.1.3. Operating principle: float/other <sup>(2)</sup> (include description or drawings): .....
  - 1.2.4.5.8.2. Level indicator:
    - 1.2.4.5.8.2.1. Make(s): .....
    - 1.2.4.5.8.2.2. Type(s): .....
    - 1.2.4.5.8.2.3. Operating principle: float/other <sup>(2)</sup> (include description or drawings): .....
  - 1.2.4.5.8.3. Pressure relief valve (discharge valve):
    - 1.2.4.5.8.3.1. Make(s): .....
    - 1.2.4.5.8.3.2. Type(s): .....
    - 1.2.4.5.8.3.3. Flow rate in standard conditions: .....
  - 1.2.4.5.8.4. Pressure relief device
    - 1.2.4.5.8.4.1. Make(s): .....
    - 1.2.4.5.8.4.2. Type(s): .....
    - 1.2.4.5.8.4.3. Description and drawings: .....
    - 1.2.4.5.8.4.4. Operating temperature: .....
    - 1.2.4.5.8.4.5. Material: .....
    - 1.2.4.5.8.4.6. Flow rate in standard condition: .....
  - 1.2.4.5.8.5. Remotely controlled service valve with excess flow valve:
    - 1.2.4.5.8.5.1. Make(s): .....
    - 1.2.4.5.8.5.2. Type(s): .....
  - 1.2.4.5.8.6. Multivalve: yes/no <sup>(2)</sup>
    - 1.2.4.5.8.6.1. Make(s): .....
    - 1.2.4.5.8.6.2. Type(s): .....
    - 1.2.4.5.8.6.3. Multivalve description (include drawings): .....
  - 1.2.4.5.8.7. Gas-tight housing:
    - 1.2.4.5.8.7.1. Make(s): .....
    - 1.2.4.5.8.7.2. Type(s): .....
  - 1.2.4.5.8.8. Power supply bushing (fuel pump/actuators):
    - 1.2.4.5.8.8.1. Make(s): .....

- 1.2.4.5.8.8.2. Type(s): .....
- 1.2.4.5.8.8.3. Drawings: .....
- 1.2.4.5.9. Fuel pump (LPG): yes/no <sup>(2)</sup>
- 1.2.4.5.9.1. Make(s): .....
- 1.2.4.5.9.2. Type(s): .....
- 1.2.4.5.9.3. Pump mounted in LPG container: yes/no <sup>(2)</sup>
- 1.2.4.5.9.4. Operating pressure(s) <sup>(1)</sup>: ..... kPa
- 1.2.4.5.10. Shut-off valve/Non-return valve/Gas tube pressure relief valve:  
yes/no <sup>(2)</sup>
- 1.2.4.5.10.1. Make(s): .....
- 1.2.4.5.10.2. Type(s): .....
- 1.2.4.5.10.3. Description and drawings: .....
- 1.2.4.5.10.4. Operating pressure(s) <sup>(1)</sup>: ..... kPa
- 1.2.4.5.11. Remote filling unit <sup>(2)</sup>:
- 1.2.4.5.11.1. Make(s): .....
- 1.2.4.5.11.2. Type(s): .....
- 1.2.4.5.11.3. Description and drawings: .....
- 1.2.4.5.12. Flexible fuel hose(s)/pipes:
- 1.2.4.5.12.1. Make(s): .....
- 1.2.4.5.12.2. Type(s): .....
- 1.2.4.5.12.3. Description: .....
- 1.2.4.5.12.4. Operating pressure(s) <sup>(1)</sup>: ..... kPa
- 1.2.4.5.13. Pressure and Temperature sensor(s) <sup>(2)</sup>:
- 1.2.4.5.13.1. Make(s): .....
- 1.2.4.5.13.2. Type(s): .....
- 1.2.4.5.13.3. Description: .....
- 1.2.4.5.13.4. Operating pressure(s) <sup>(1)</sup>: ..... kPa
- 1.2.4.5.14. LPG filter unit(s) <sup>(2)</sup>:
- 1.2.4.5.14.1. Make(s): .....
- 1.2.4.5.14.2. Type(s): .....
- 1.2.4.5.14.3. Description: .....
- 1.2.4.5.14.4. Operating pressure(s) <sup>(1)</sup>: ..... kPa



- 1.2.4.5.15. Service coupling(s) (mono-fuel vehicles without limp-home system) <sup>(2)</sup>:
- 1.2.4.5.15.1. Make(s): .....
- 1.2.4.5.15.2. Type(s): .....
- 1.2.4.5.15.3. Description and drawings of installation: .....
- 1.2.4.5.16. Connection to LPG system for heating system: yes/no <sup>(2)</sup>
- 1.2.4.5.16.1. Make(s): .....
- 1.2.4.5.16.2. Type(s): .....
- 1.2.4.5.16.3. Description and drawings of installation: .....
- 1.2.4.5.17. Fuel rail <sup>(2)</sup>:
- 1.2.4.5.17.1. Make(s): .....
- 1.2.4.5.17.2. Type(s): .....
- 1.2.4.5.17.3. Description and drawings of installation: .....
- 1.2.4.5.17.4. Operating pressure(s) <sup>(1)</sup>: ..... kPa
- 1.2.4.5.18. Multi-component <sup>(2)</sup>:
- 1.2.4.5.18.1. Make(s): .....
- 1.2.4.5.18.2. Type(s): .....
- 1.2.4.5.18.3. Description and drawings: .....
- 1.2.4.5.18.4. Operating pressure(s) <sup>(1)</sup>: ..... kPa
- 1.2.4.5.19. Further documentation:
- 1.2.4.5.19.1. Description of the LPG equipment and the physical safeguarding of the catalyst at switch-over from petrol to LPG or back
- 1.2.4.5.19.2. System lay-out (electrical connections, vacuum connections compensation hoses, etc.)
- 1.2.4.5.19.3. Drawing of the symbol: .....
- 1.2.4.5.19.4. Adjustment data: .....
- 1.2.4.5.19.5. Certificate of the vehicle on petrol, if already granted: .....
- 1.2.5. Cooling system: (liquid/air) <sup>(2)</sup>
- 1.2.5.1. System description/drawings with regard to the LPG equipment

<sup>(1)</sup> Specify the tolerance.

<sup>(2)</sup> Strike out what does not apply.

## ANNEX 2A

## ARRANGEMENT OF THE LPG EQUIPMENT TYPE APPROVAL MARK

(See paragraph 5.4 of this Regulation)

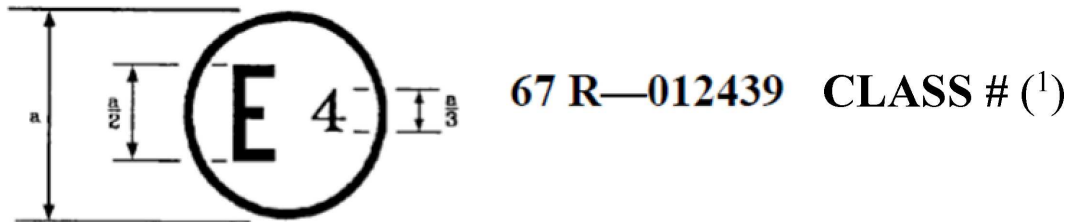
 $a \geq 5 \text{ mm}$ <sup>(1)</sup> Class 0, 1, 2, 2A or 3

The above approval mark affixed to the LPG equipment shows that this equipment has been approved in the Netherlands (E 4), pursuant to Regulation No 67 under approval number 012439. The first two digits of the approval number indicate that the approval was granted in accordance with the requirements of Regulation No 67 as amended by the 01 series of amendments.

ANNEX 2B

COMMUNICATION

(Maximum format: A4 (210 × 297 mm))

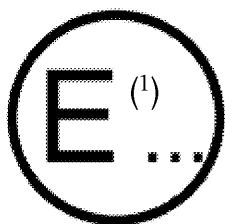

issued by: Name of administration

.....  
.....  
.....

- Concerning <sup>(2)</sup>: Approval granted
- Approval extended
- Approval refused
- Approval withdrawn
- Production definitively discontinued

of a type of LPG equipment pursuant to Regulation No 67

Approval No: ..... Extension No: .....

1. LPG equipment considered <sup>(2)</sup>:

Container including the configuration of accessories fitted to the container, as laid down in Appendix 1 to this annex.

80 per cent stop valve

Level indicator

Pressure relief valve (discharge valve)

Pressure relief device

Remotely controlled service valve with excess flow valve

Multivalve, including the following accessories: .....

Gas-tight housing

Power supply bushing (pump/actuators)

Fuel pump

Vaporiser/pressure regulator

Shut-off valve

Non-return valve

Gas-tube pressure relief valve

Service coupling

Flexible hose

Remote filling unit

Gas injection device or injector

Fuel rail

Gas dosage unit

Gas mixing piece

Electronic control unit

Pressure/temperature sensor

LPG filter unit

Multi-component

2. Trade name or mark: .....
3. Manufacturer's name and address: .....
4. If applicable, name and address of manufacturer's representative: .....
5. Submitted for approval on: .....
6. Technical Service responsible for conducting approval tests: .....
7. Date of report issued by that Service: .....
8. No of report issued by that Service: .....
9. Approval granted/refused/extended/withdrawn <sup>(1)</sup>: .....
10. Reason(s) of extension (if applicable): .....
11. Place: .....
12. Date: .....
13. Signature: .....
14. The documents filed with the application or extension of approval can be obtained upon request.

---

<sup>(1)</sup> Distinguishing number of the country which has granted/extended/refused/withdrawn approval (see approval provisions in the Regulation).

<sup>(2)</sup> Strike out what does not apply.

---

## Appendix

## CONTAINERS ONLY

1. Container characteristics from the parent container (configuration 00):
  - (a) Trade name or mark: .....
  - (b) Shape: .....
  - (c) Material: .....
  - (d) Openings: ..... see drawing
  - (e) Wall thickness: ..... mm
  - (f) Diameter (cylindrical container): ..... mm
  - (g) Height (special container shape): ..... mm
  - (h) External surface: ..... cm<sup>2</sup>
  - (i) Configuration of accessories fitted to container: see Table 1.

Table 1

No	Item	Type	Approval No	Extension No
a	80 per cent stop valve			
b	Level indicator			
c	Pressure relief valve			
d	Remotely controlled service valve with excess valve			
e	Fuel pump			
f	Multi-valve			
g	Gas-tight housing			
h	Power supply bushing			
i	Non-return valve			
j	Pressure relief device			

2. Lists of the container family

The lists of the container family indicate the diameter, capacity, external surface and the possible configuration(s) of the accessories fitted to the container.

Table 2

No	Type	Diameter/height [mm]	Capacity [L]	External surface [cm <sup>2</sup> ]	Configuration of accessories [codes] <sup>(1)</sup>
01					
02					

<sup>(1)</sup> Code 00 and, if applicable, same code(s) from Table 3.

3. Lists of the possible configurations of accessories fitted to the container

Specify a list of the possible accessories, which differ from the tested configuration of accessories (code 00) and which may be fitted to the type of container. Specify for all accessories, type, approval number and extension number, indicating its own configuration code.

Table 3

No	Accessories	Type	Approval No	Extension No	Configuration of accessories [code]
a					
b					
c					
d					

## ANNEX 2C

## ARRANGEMENT OF APPROVAL MARKS

## Model A

(See paragraph 16.4 of this Regulation)

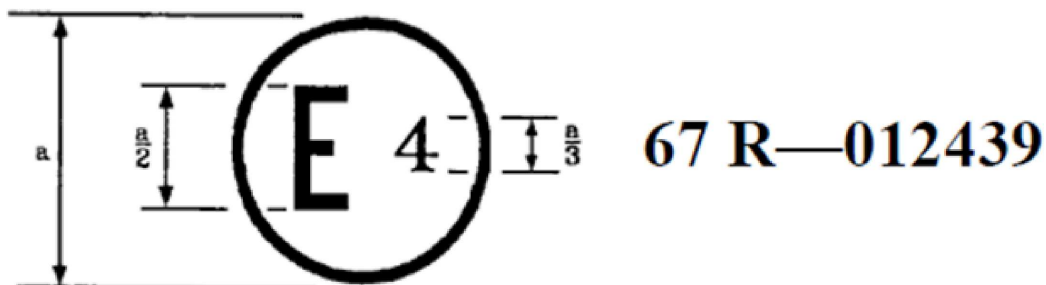

a ≥ 8 mm

The above approval mark affixed to a vehicle shows that the vehicle has, with regard to the installation of specific equipment for the use of LPG for propulsion, been approved in the Netherlands (E 4), pursuant to Regulation No 67 under approval number 012439. The first two digits of the approval number indicate that the approval was granted in accordance with the requirements of Regulation No 67 as amended by the 01 series of amendments.

## Model B

(See paragraph 16.4 of this Regulation)

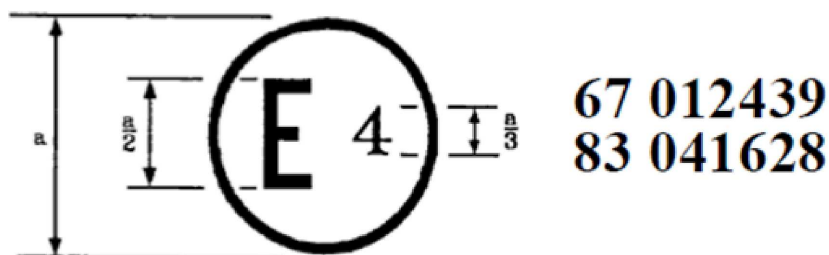

a ≥ 8 mm

The above approval mark affixed to a vehicle shows that the vehicle has, with regard to the installation of specific equipment for the use of LPG for propulsion, been approved in the Netherlands (E 4), pursuant to Regulation No 67 under approval number 012439. The first two digits of the approval number indicate that the approval was granted in accordance with the requirements of Regulation No 67 as amended by the 01 series of amendments and that Regulation No 83 included the 04 series of amendments.

ANNEX 2D

COMMUNICATION

(Maximum format: A4 (210 × 297 mm))

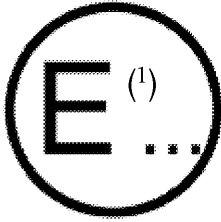

issued by: Name of administration

.....  
.....  
.....

- Concerning <sup>(2)</sup>: Approval granted
- Approval extended
- Approval refused
- Approval withdrawn
- Production definitively discontinued

of a vehicle type with regard to the installation of LPG systems pursuant to Regulation No 67

Approval No: ..... Extension No: .....

1. Trade name or mark of vehicle: .....
2. Vehicle type: .....
3. Vehicle category: .....
4. Manufacturer's name and address: .....
5. If applicable, name and address of manufacturer's representative: .....
6. Description of the vehicle (drawings, etc.)
7. Test results: .....
8. Submitted for approval on: .....
9. Technical Service responsible for conducting approval tests: .....
10. Date of report issued by that Service: .....
11. No of report issued by that Service: .....
12. Approval granted/refused/extended/withdrawn <sup>(2)</sup>:
13. Reason(s) of extension (if applicable): .....
14. Place: .....
15. Date: .....
16. Signature: .....

17. The following documents filed with the application or extension of approval can be obtained upon request.

Drawings, diagrams and scheme plans regarding the components and the installation of the LPG equipment considered to be of importance for the purpose of this Regulation;

Where applicable drawings of the various equipment and their position in the vehicle.

<sup>(1)</sup> Distinguishing number of the country which has granted/extended/refused/withdrawn approval (see approval provisions in the Regulation).

<sup>(2)</sup> Strike out what does not apply.



## ANNEX 3

**PROVISIONS REGARDING THE APPROVAL OF LPG CONTAINER ACCESSORIES**

## 1. 80 per cent stop valve

1.1. Definition: See paragraph 2.5.1 of this Regulation.

1.2. Component classification (according to Figure 1, para. 2): Class 3.

1.3. Classification pressure: 3 000 kPa.

1.4. Design temperatures:

– 20 °C to 65 °C

For temperatures exceeding the abovementioned values, special tests conditions are applicable.

1.5. General design rules:

Paragraph 6.15.1, Provisions regarding 80 per cent stop valve.

Paragraph 6.15.2, Provisions regarding the electrical insulation.

Paragraph 6.15.3.1, Provisions on valves activated by electrical power.

1.6. Applicable test procedures:

Overpressure test	Annex 15, para. 4
External leakage	Annex 15, para. 5
High temperature	Annex 15, para. 6
Low temperature	Annex 15, para. 7
Seat leakage	Annex 15, para. 8
Endurance	Annex 15, para. 9
Operational tests	Annex 15, para. 10
LPG compatibility	Annex 15, para. 11 (**)
Corrosion resistance	Annex 15, para. 12 (*)
Resistance to dry heat	Annex 15, para. 13 (**)
Ozone ageing	Annex 15, para. 14 (**)
Creep	Annex 15, para. 15 (**)
Temperature cycle	Annex 15, para. 16 (**)

## 2. Level indicator

2.1. Definition: see paragraph 2.5.2 of this Regulation.

2.2. Component classification (according to Figure 1, para. 2): Class 1.

2.3. Classification pressure: 3 000 kPa.

#### 2.4. Design temperatures:

– 20 °C to 65 °C

For temperatures exceeding the abovementioned values, special tests conditions are applicable.

#### 2.5. General design rules:

Paragraph 6.15.11, Provisions regarding the level indicator.

Paragraph 6.15.2, Provisions regarding the electrical insulation.

#### 2.6. Applicable test procedures:

Overpressure test	Annex 15, para. 4
External leakage	Annex 15, para. 5
High temperature	Annex 15, para. 6
Low temperature	Annex 15, para. 7
LPG compatibility	Annex 15, para. 11 (**)
Corrosion resistance	Annex 15, para. 12 (*)
Resistance to dry heat	Annex 15, para. 13 (**)
Ozone ageing	Annex 15, para. 14 (**)
Creep	Annex 15, para. 15 (**)
Temperature cycle	Annex 15, para. 16 (**)

### 3. Pressure relief valve (discharge valve)

3.1. Definition: See paragraph 2.5.3 of this Regulation.

3.2. Component classification (according to Figure 1, para. 2): Class 3.

3.3. Classification pressure: 3 000 kPa.

#### 3.4. Design temperatures:

– 20 °C to 65 °C

For temperatures exceeding the abovementioned values, special tests conditions are applicable.

#### 3.5. General design rules:

Paragraph 6.15.8, Provisions regarding the pressure relief valve (discharge valve)

#### 3.6. Applicable test procedures:

Overpressure test	Annex 15, para. 4
External leakage	Annex 15, para. 5
High temperature	Annex 15, para. 6
Low temperature	Annex 15, para. 7

Seat leakage	Annex 15, para. 8
Endurance (with 200 operation cycles)	Annex 15, para. 9
Operational test	Annex 15, para. 10
LPG compatibility	Annex 15, para. 11 (**)
Corrosion resistance	Annex 15, para. 12 (*)
Resistance to dry heat	Annex 15, para. 13 (**)
Ozone ageing	Annex 15, para. 14 (**)
Creep	Annex 15, para. 15 (**)
Temperature cycle	Annex 15, para. 16 (**)

#### 4. Remotely controlled service valve with excess flow valve

4.1. Definition: see paragraph 2.5.4 of this Regulation.

4.2. Component classification (according to Figure 1, para. 2): Class 3 or Class 0 if WP declared.

4.3. Classification pressure: 3 000 kPa or WP declared if  $\geq 3\ 000$  kPa.

4.4. Design temperatures:

– 20 °C to 65 °C

For temperatures exceeding the abovementioned values, special tests conditions are applicable.

4.5. General design rules:

Paragraph 6.15.2, Provisions regarding the electrical insulation.

Paragraph 6.15.3.1, Provisions on valves activated by an electrical/external power.

Paragraph 6.15.13, Provisions regarding the remotely controlled service valve with excess flow valve.

4.6. Applicable test procedures:

Overpressure test	Annex 15, para. 4
External leakage	Annex 15, para. 5
High temperature	Annex 15, para. 6
Low temperature	Annex 15, para. 7
Seat leakage	Annex 15, para. 8
Endurance	Annex 15, para. 9
Operational test	Annex 15, para. 10
LPG compatibility	Annex 15, para. 11 (**)
Corrosion resistance	Annex 15, para. 12 (*)
Resistance to dry heat	Annex 15, para. 13 (**)
Ozone ageing	Annex 15, para. 14 (**)
Creep	Annex 15, para. 15 (**)
Temperature cycle	Annex 15, para. 16 (**)

4.7. If the remotely controlled service valve is closed during commanded stop phases, the valve shall be submitted to the following numbers of operations during the endurance test of paragraph 9 of Annex 15:

- (a) 200 000 cycles (mark 'H<sub>1</sub>') if the engine shuts off automatically when the vehicle comes to a halt.
- (b) 500 000 cycles (mark 'H<sub>2</sub>') if, in addition to (a), the engine also shuts off automatically when the vehicle drives with the electric motor only.
- (c) 1 000 000 cycles (mark 'H<sub>3</sub>') if, in addition to (a) or (b), the engine also shuts off automatically when the accelerator pedal is released.

Notwithstanding the abovementioned provisions, the valve complying with (b) shall be deemed to satisfy (a), and the valve complying with (c) shall be deemed to satisfy (a) and (b).

## 5. Power supply bushing

5.1. Definition: see paragraph 2.5.8 of this Regulation.

5.2. Component classification (according to Figure 1, para. 2):

Class 0 for the part which is in contact with liquid LPG at a pressure > 3 000 kPa;

Class 1 for the part which is in contact with liquid LPG at a pressure ≤ 3 000 kPa.

5.3. Classification pressure:

Parts of Class 0 WP declared

Parts of Class 1 3 000 kPa

5.4. Design temperatures:

– 20 °C to 65 °C

For temperatures exceeding the abovementioned values, special tests conditions are applicable.

5.5. General design rules:

Paragraph 6.1.5.2, Provisions regarding the electrical insulation.

Paragraph 6.1.5.2.3, Provisions regarding the power supply bushing.

5.6. Applicable test procedures:

Overpressure test	Annex 15, para. 4
External leakage	Annex 15, para. 5
High temperature	Annex 15, para. 6
Low temperature	Annex 15, para. 7
LPG compatibility	Annex 15, para. 11 (**)
Corrosion resistance	Annex 15, para. 12 (*)
Resistance to dry heat	Annex 15, para. 13 (**)
Ozone ageing	Annex 15, para. 14 (**)
Creep	Annex 15, para. 15 (**)
Temperature cycle	Annex 15, para. 16 (**)

6. Gas-tight housing

6.1. Definition: See paragraph 2.5.7 of this Regulation.

6.2. Component classification (according to Figure 1, para. 2):

Not applicable.

6.3. Classification pressure: Not applicable.

6.4. Design temperatures:

– 20 °C to 65 °C

For temperatures exceeding the abovementioned values, special tests conditions are applicable.

6.5. General design rules:

Paragraph 6.15.12, Provisions regarding the gas-tight housing.

6.6. Applicable test procedures:

Overpressure test	Annex 15, para. 4 (at 50 kPa)
External leakage	Annex 15, para. 5 (at 10 kPa)
High temperature	Annex 15, para. 6
Low temperature	Annex 15, para. 7

7. Provisions regarding the approval of the pressure relief device (fuse)

7.1. Definition: see paragraph 2.5.3.1 of this Regulation.

7.2. Component classification (according to Figure 1, paragraph 2): Class 3.

7.3. Classification pressure: 3 000 kPa.

7.4. Design temperature:

The fuse has to be designed to open at a temperature of  $120 \pm 10$  °C

7.5. General design rules

Paragraph 6.15.2, Provisions regarding the electrical insulation

Paragraph 6.15.3.1, Provisions on valves activated by electrical power

Paragraph 6.15.7, Provisions regarding the gas tube pressure relief valve

7.6. Test procedures to be applied:

Overpressure test	Annex 15, para. 4
External leakage	Annex 15, para. 5
High temperature	Annex 15, para. 6
Low temperature	Annex 15, para. 7

Seat (if any) leakage	Annex 15, para. 8
LPG compatibility	Annex 15, para. 11 (**)
Corrosion resistance	Annex 15, para. 12 (*)
Resistance to dry heat	Annex 15, para. 13 (**)
Ozone ageing	Annex 15, para. 14 (**)
Creep	Annex 15, para. 15 (**)
Temperature cycles	Annex 15, para. 16 (**)

#### 7.7. Pressure relief device (fuse) requirements

Pressure relief device (fuse) specified by the manufacturer shall be shown to be compatible with the service conditions by means of the following tests:

- (a) One specimen shall be held at a controlled temperature of not less than 90 °C and a pressure not less than test pressure (3 000 kPa) for 24 hours. At the end of this test there shall be no leakage or visible sign of extrusion of any fusible metal used in the design.
- (b) One specimen shall be fatigue tested at a pressure cycling rate not to exceed 4 cycles per minute as follows:
  - (i) Held at 82 °C while pressured for 10 000 cycles between 300 and 3 000 kPa;
  - (ii) Held at – 20 °C while pressured for 10 000 cycles between 300 and 3 000 kPa.

At the end of this test there shall be no leakage, or any visible sign of extrusion of any fusible metal used in the design.

- (c) Exposed brass pressure retaining components of pressure relief device shall withstand, without stress corrosion cracking, a mercurous nitrate test as described in ASTM B154 (\*\*). The pressure relief device shall be immersed for 30 minutes in an aqueous mercurous nitrate solution containing 10 g of mercurous nitrate and 10 ml of nitric acid per litre of solution. Following the immersion, the pressure relief device shall be leak tested by applying an aerostatic pressure of 3 000 kPa for one minute during which time the component shall be checked for external leakage. Any leakage shall not exceed 200 cm<sup>3</sup>/h.
- (d) Exposed stainless steel pressure retaining components of pressure relief device shall be made of an alloy type resistant to chloride induced stress corrosion cracking.

---

(\*) Only for metallic parts.

(\*\*) Only for non-metallic parts.

(\*\*\*) This procedure, or other equivalent, is allowed until an international standard will be available.

## ANNEX 4

**PROVISIONS REGARDING THE APPROVAL OF THE FUEL PUMP**

1. Definition: See paragraph 2.5.5 of this Regulation.
2. Component classification (according to Figure 1, para. 2):
  - Class 0 for the part which is in contact with liquid LPG at a pressure > 3 000 kPa;
  - Class 1 for the part which is in contact with liquid LPG at a pressure ≤ 3 000 kPa.
3. Classification pressure:
  - Parts of Class 0 WP declared
  - Parts of Class 1 3 000 kPa
4. Design temperatures:
  - 20 °C to 65 °C, when the fuel pump is mounted inside the container.
  - 20 °C to 120 °C, when the fuel pump is mounted outside the container.

For temperatures exceeding the abovementioned values, special tests conditions are applicable.
5. General design rules:
  - Paragraph 6.15.2, Provisions regarding the electrical insulation.
  - Paragraph 6.15.2.1, Provisions regarding the insulation class.
  - Paragraph 6.15.3.2, Provisions when the power is switched off.
  - Paragraph 6.15.6.1, Provisions to prevent pressure build-up.
6. Applicable test procedures:
  - 6.1. Fuel pump mounted inside the container:
    - LPG compatibility Annex 15, para. 11 (\*\*)
  - 6.2. Fuel pump mounted outside the container:
 

Overpressure test	Annex 15, para. 4
External leakage	Annex 15, para. 5
High temperature	Annex 15, para. 6
Low temperature	Annex 15, para. 7
LPG compatibility	Annex 15, para. 11 (**)
Corrosion resistance	Annex 15, para. 12 (*)
Resistance to dry heat	Annex 15, para. 13 (**)
Ozone ageing	Annex 15, para. 14 (**)
Creep	Annex 15, para. 15 (**)
Temperature cycle	Annex 15, para. 16 (**)

---

(\*) Only for metallic parts.

(\*\*) Only for non-metallic parts.

## ANNEX 5

## PROVISIONS REGARDING THE APPROVAL OF THE LPG FILTER UNIT

1. Definition: See paragraph 2.14 of this Regulation.
2. Component classification (according to Figure 1, para. 2):  
Filter units can be Class 0, 1, 2 or 2A.
3. Classification pressure:  
Components of Class 0: WP declared  
Components of Class 1: 3 000 kPa.  
Components of Class 2: 450 kPa.  
Components of Class 2A: 120 kPa.
4. Design temperatures:  
– 20 °C to 120 °C  
  
For temperatures exceeding the abovementioned values, special tests conditions are applicable.
5. General design rules: (not used)
6. Applicable test procedures:
  - 6.1. For parts of Class 1:
 

Overpressure test	Annex 15, para. 4
External leakage	Annex 15, para. 5
High temperature	Annex 15, para. 6
Low temperature	Annex 15, para. 7
LPG compatibility	Annex 15, para. 11 (**)
Corrosion resistance	Annex 15, para. 12 (*)
Resistance to dry heat	Annex 15, para. 13 (**)
Ozone ageing	Annex 15, para. 14 (**)
Creep	Annex 15, para. 15 (**)
Temperature cycle	Annex 15, para. 16 (**)
  - 6.2. For parts of Class 2 and/or 2A:
 

Overpressure test	Annex 15, para. 4
External leakage	Annex 15, para. 5
High temperature	Annex 15, para. 6
Low temperature	Annex 15, para. 7
LPG compatibility	Annex 15, para. 11 (**)
Corrosion resistance	Annex 15, para. 12 (**)

(\*) Only for metallic parts.

(\*\*) Only for non-metallic parts.



## ANNEX 6

**PROVISIONS REGARDING THE APPROVAL OF THE PRESSURE REGULATOR AND THE VAPORISER**

## 1. Definition:

Vaporiser: See paragraph 2.6 of this Regulation.

Pressure regulator: see paragraph 2.7 of this Regulation.

## 2. Component classification (according to Figure 1, para. 2):

Class 0: for the part which is in contact with LPG at a pressure  $> 3\ 000$  kPa.

Class 1: for the part which is in contact with the pressure  $\leq 3\ 000$  kPa.

Class 2: for the part which is in contact with the regulated pressure and with a maximum regulated pressure during operation of 450 kPa.

Class 2A: for the part which is in contact with the regulated pressure and with a maximum regulated pressure during operation of 120 kPa.

## 3. Classification pressure:

Parts of Class 0: WP declared

Parts of Class 1: 3 000 kPa.

Parts of Class 2: 450 kPa.

Parts of Class 2A: 120 kPa.

## 4. Design temperatures:

– 20 °C to 120 °C

For temperatures exceeding the abovementioned values, special tests conditions are applicable.

## 5. General design rules:

Paragraph 6.15.2, Provisions regarding the electrical insulation.

Paragraph 6.15.3.1, Provisions on valves activated by external power.

Paragraph 6.15.4, Heat exchange medium (compatibility and pressure requirements).

Paragraph 6.15.5, Overpressure bypass security.

Paragraph 6.15.6.2, Gas flow prevention.

## 6. Applicable test procedures:

## 6.1. For parts of Class 1:

Overpressure test	Annex 15, para. 4
External leakage	Annex 15, para. 5
High temperature	Annex 15, para. 6
Low temperature	Annex 15, para. 7
Seat leakage	Annex 15, para. 8
Endurance (Number of cycles shall be 50 000 cycles)	Annex 15, para. 9

LPG compatibility	Annex 15, para. 11 (**)
Corrosion resistance	Annex 15, para. 12 (*)
Resistance to dry heat	Annex 15, para. 13 (**)
Ozone ageing	Annex 15, para. 14 (**)
Creep	Annex 15, para. 15 (**)
Temperature cycle	Annex 15, para. 16 (**)
6.2. For parts of Class 2 and/or 2A:	
Overpressure test	Annex 15, para. 4
External leakage	Annex 15, para. 5
High temperature	Annex 15, para. 6
Low temperature	Annex 15, para. 7
LPG compatibility	Annex 15, para. 11 (**)
Corrosion resistance	Annex 15, para. 12 (*)

Remarks:

The shut-off valve can be integrated in the vaporiser, regulator, in this case Annex 7 is also applicable.

The parts of the pressure regulator/vaporiser (Class 1, 2 or 2A) shall be leak proof with the outlet(s) of that part closed off.

For the overpressure test all the outlets including those of the coolant compartment shall be closed off.

---

(\*) Only for metallic parts.

(\*\*) Only for non-metallic parts.

## ANNEX 7

**PROVISIONS REGARDING THE APPROVAL OF THE SHUT-OFF VALVE, THE NON-RETURN VALVE, THE GAS-TUBE PRESSURE RELIEF VALVE AND THE SERVICE COUPLING**

## 1. Provisions regarding the approval of the shut-off valve

1.1. Definition: See paragraph 2.8 of this Regulation.

1.2. Component classification (according to Figure 1, para. 2): Class 3.

1.3. Classification pressure: 3 000 kPa or WP declared if &gt; 3 000 kPa.

1.4. Design temperatures:

– 20 °C to 120 °C

For temperatures exceeding the abovementioned values, special tests conditions are applicable.

1.5. General design rules:

Paragraph 6.15.2, Provisions regarding the electrical insulation.

Paragraph 6.15.3.1, Provisions on valves activated by electrical power.

1.6. Applicable test procedures:

Overpressure test	Annex 15, para. 4
External leakage	Annex 15, para. 5
High temperature	Annex 15, para. 6
Low temperature	Annex 15, para. 7
Seat leakage	Annex 15, para. 8
Endurance	Annex 15, para. 9
LPG compatibility	Annex 15, para. 11 (**)
Corrosion resistance	Annex 15, para. 12 (*)
Resistance to dry heat	Annex 15, para. 13 (**)
Ozone ageing	Annex 15, para. 14 (**)
Creep	Annex 15, para. 15 (**)
Temperature cycle	Annex 15, para. 16 (**)

1.7. If the remotely controlled shut-off valve is closed during commanded stop phases, the valve shall be submitted to the numbers of operations according to paragraph 4.7 of Annex 3 during the endurance test of paragraph 9 of Annex 15.

## 2. Provisions regarding the approval of the non-return valve

2.1. Definition: See paragraph 2.5.9 of this Regulation.

2.2. Component classification (according to Figure 1, para. 2): Class 1.

2.3. Classification pressure: 3 000 kPa.

2.4. Design temperatures:

– 20 °C to 120 °C

For temperatures exceeding the abovementioned values, special tests conditions are applicable.

2.5. General design rules:

Paragraph 6.15.2, Provisions regarding the electrical insulation.

Paragraph 6.15.3.1, Provisions on valves activated by electrical power.

2.6. Applicable test procedures:

Overpressure test	Annex 15, para. 4
External leakage	Annex 15, para. 5
High temperature	Annex 15, para. 6
Low temperature	Annex 15, para. 7
Seat leakage	Annex 15, para. 8
Endurance	Annex 15, para. 9
LPG compatibility	Annex 15, para. 11 (**)
Corrosion resistance	Annex 15, para. 12 (*)
Resistance to dry heat	Annex 15, para. 13 (**)
Ozone ageing	Annex 15, para. 14 (**)
Creep	Annex 15, para. 15 (**)
Temperature cycle	Annex 15, para. 16 (**)

3. Provisions regarding the approval of the gas-tube relief valve

3.1. Definition: See paragraph 2.9 of this Regulation.

3.2. Component classification (according to Figure 1, para. 2): Class 3.

3.3. Classification pressure: 3 000 kPa or WP declared if > 3 000 kPa.

3.4. Design temperatures:

– 20 °C to 120 °C

For temperatures exceeding the abovementioned values, special tests conditions are applicable.

3.5. General design rules:

Paragraph 6.15.2, Provisions regarding the electrical insulation.

Paragraph 6.15.3.1, Provisions on valves activated by electrical power.

Paragraph 6.15.7, Provisions regarding the gas-tube pressure relief valve.

3.6. Applicable test procedures:

Overpressure test	Annex 15, para. 4
External leakage	Annex 15, para. 5
High temperature	Annex 15, para. 6
Low temperature	Annex 15, para. 7
Seat leakage	Annex 15, para. 8
Endurance (with 200 operation cycles)	Annex 15, para. 9
LPG compatibility	Annex 15, para. 11 (**)

Corrosion resistance	Annex 15, para. 12 (*)
Resistance to dry heat	Annex 15, para. 13 (**)
Ozone ageing	Annex 15, para. 14 (**)
Creep	Annex 15, para. 15 (**)
Temperature cycle	Annex 15, para. 16 (**)

4. Provisions regarding the approval of the service coupling

4.1. Definition: See paragraph 2.17 of this Regulation.

4.2. Component classification (according to Figure 1, para. 2): Class 1.

4.3. Classification pressure: 3 000 kPa.

4.4. Design temperatures:

– 20 °C to 120 °C

For temperatures exceeding the abovementioned values, special tests conditions are applicable.

4.5. General design rules:

Paragraph 6.15.2, Provisions regarding the electrical insulation.

Paragraph 6.15.3.1, Provisions on valves activated by electrical power.

4.6. Applicable test procedures:

Overpressure test	Annex 15, para. 4
External leakage	Annex 15, para. 5
High temperature	Annex 15, para. 6
Low temperature	Annex 15, para. 7
Seat leakage	Annex 15, para. 8
Endurance (with 6 000 operation cycles)	Annex 15, para. 9
LPG compatibility	Annex 15, para. 11 (**)
Corrosion resistance	Annex 15, para. 12 (*)
Resistance to dry heat	Annex 15, para. 13 (**)
Ozone ageing	Annex 15, para. 14 (**)
Creep	Annex 15, para. 15 (**)
Temperature cycle	Annex 15, para. 16 (**)

(\*) Only for metallic parts.

(\*\*) Only for non-metallic parts.

## ANNEX 8

**PROVISIONS REGARDING THE APPROVAL OF FLEXIBLE HOSES WITH COUPLINGS**

## Scope

The purpose of this annex is to determine the provisions regarding the approval of flexible hoses for use with LPG, having an inside diameter up to 20 mm.

This annex covers four types of flexible hoses:

- (a) High pressure rubber hoses (Class 1, e.g. Filling hose);
- (b) Low pressure rubber hoses (Class 2);
- (c) High pressure synthetic hoses (Class 1);
- (d) High pressure synthetic hoses (Class 0).

1. High pressure rubber hoses, Class 1 classification, filling hose

1.1. General specifications

1.1.1. The hose shall be so designed as to withstand a maximum operating pressure of 3 000 kPa.

1.1.2. The hose shall be so designed as to withstand temperatures between – 25 °C and + 80 °C. For operating temperatures exceeding the abovementioned values, the test temperatures shall be adapted.

1.1.3. The inside diameter shall be in compliance with Table 1 of standard ISO 1307.

1.2. Hose construction

1.2.1. The hose shall embody a smooth-bore tube and a cover of suitable synthetic material, reinforced with one or more interlayer(s).

1.2.2. The reinforcing interlayer(s) has (have) to be protected by a cover against corrosion.

If for the reinforcing interlayer(s) corrosion-resistant-material is used (i.e. stainless-steel) a cover is not required.

1.2.3. The lining and the cover shall be smooth and free from pores, holes and strange elements.

An intentionally provided puncture in the cover shall not be considered as an imperfection.

1.2.4. The cover has to be intentionally perforated to avoid the forming of bubbles.

1.2.5. When the cover is punctured and the interlayer is made of a non-corrosion-resistant material, the interlayer has to be protected against corrosion.

1.3. Specifications and tests for the lining

1.3.1. Tensile strength and elongation

1.3.1.1. Tensile strength and elongation at break according to ISO 37. Tensile strength not less than 10 MPa and elongation at break not less than 250 per cent.

1.3.1.2. Resistance to n-pentane according to ISO 1817 with the following conditions:

- (a) Medium: n-pentane;
- (b) Temperature: 23 °C (tolerance acc. to ISO 1817);
- (c) Immersion period: 72 hours.

Requirements:

- (a) Maximum change in volume 20 per cent;
- (b) Maximum change in tensile strength 25 per cent;
- (c) Maximum change in elongation at break 30 per cent.

After storage in air with a temperature of 40 °C for a period of 48 hours the mass compared to the original value may not decrease more than 5 per cent.

1.3.1.3. Resistance to ageing according to ISO 188 with the following conditions:

- (a) Temperature: 70 °C (test temperature = maximum operating temperature minus 10 °C);
- (b) Exposure period: 168 hours.

Requirements:

- (a) Maximum change in tensile strength 25 per cent;
- (b) Maximum change in elongation at break – 30 per cent and + 10 per cent.

1.4. Specifications and test-method for the cover

1.4.1. Tensile strength and elongation at break according to ISO 37. Tensile strength not less than 10 MPa and elongation at break not less than 250 per cent.

1.4.1.1. Resistance to n-hexane according to ISO 1817 with the following conditions:

- (a) Medium: n-hexane;
- (b) Temperature: 23 °C (tolerance acc. to ISO 1817);
- (c) Immersion period: 72 hours.

Requirements:

- (a) Maximum change in volume 30 per cent;
- (b) Maximum change in tensile strength 35 per cent;
- (c) Maximum change in elongation at break 35 per cent.

1.4.1.2. Resistance to ageing according to ISO 188 with the following conditions:

- (a) Temperature: 70 °C (test temperature = maximum operating temperature minus 10 °C);
- (b) Exposure period: 336 hours.

Requirements:

- (a) Maximum change in tensile strength 25 per cent;
- (b) Maximum change in elongation at break – 30 per cent and + 10 per cent.

1.4.2. Resistance to ozone

1.4.2.1. The test has to be performed in compliance with standard ISO 1431/1.

1.4.2.2. The test-pieces, which have to be stretched to an elongation of 20 per cent shall have to be exposed to air of 40 °C with an ozone-concentration of 50 parts per hundred million during 120 hours.

1.4.2.3. No cracking of the test pieces is allowed.

- 1.5. Specifications for uncoupled hose
- 1.5.1. Gas-tightness (permeability)
- 1.5.1.1. A hose at a free length of 1 m has to be connected to a container filled with liquid propane, having a temperature of  $23\text{ °C} \pm 2\text{ °C}$ .
- 1.5.1.2. The test has to be carried out in compliance with the method described in standard ISO 4080.
- 1.5.1.3. The leakage through the wall of the hose shall not exceed  $95\text{ cm}^3$  of vapour per metre of hose per 24 h.
- 1.5.2. Resistance at low temperature
- 1.5.2.1. The test has to be carried out in compliance with the method described in standard ISO 4672:1978 method B.
- 1.5.2.2. Test-temperature:  $-25\text{ °C} \pm 3\text{ °C}$ .
- 1.5.2.3. No cracking or rupture is allowed.
- 1.5.3. (Not used)
- 1.5.4. Bending test
- 1.5.4.1. An empty hose, at a length of approximately 3,5 m shall be able to withstand 3 000 times the hereafter prescribed alternating-bending-test without breaking. After the test the hose shall be capable of withstanding the test-pressure as mentioned in paragraph 1.5.5.2 below.
- 1.5.4.2.

Figure 1 (example only)

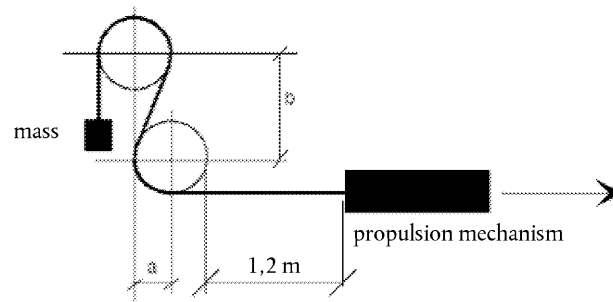

Hose inside diameter [mm]	Bending radius [mm] (Figure 1)	Distance between centres [mm] (Figure 1)	
		Vertical b	Horizontal a
up to 13	102	241	102
13 to 16	153	356	153
from 16 to 20	178	419	178

- 1.5.4.3. The testing machine (see Figure 1) shall consist of a steel frame, provided with two wooden wheels, with a rim-width of c.a. 130 mm.

The circumference of the wheels shall be grooved for the guidance of the hose. The radius of the wheels, measured to the bottom of the groove, shall be as indicated in paragraph 1.5.4.2 above.



The longitudinal median planes of both wheels shall be in the same vertical plane and the distance between the wheel-centres shall be in accordance with paragraph 1.5.4.2.

Each wheel shall be able to rotate freely round its pivot-centre.

A propulsion mechanism pulls the hose over the wheels at a speed of four complete motions per minute.

1.5.4.4. The hose shall be S-shape-like installed over the wheels (see Figure 1).

The end that runs over the upper wheel shall be furnished with a sufficient mass as to achieve a complete snuggling of the hose against the wheels. The part that runs over the lower wheel is attached to the propulsion mechanism.

The mechanism shall be so adjusted, that the hose travels a total distance of 1,2 m in both directions.

1.5.5. Hydraulic test pressure and determination of the minimum burst-pressure

1.5.5.1. The test has to be carried out in compliance with the method described in standard ISO 1402.

1.5.5.2. The test-pressure of 6 750 kPa shall be applied during 10 minutes, without any leakage.

1.5.5.3. The burst pressure shall not be less than 10 000 kPa.

1.6. Couplings

1.6.1. The couplings shall be made from steel or brass and the surface shall be corrosion-resistant.

1.6.2. The couplings shall be of the crimp-fitting type.

1.6.2.1. The swivel-nut shall be provided with U.N.F. thread.

1.6.2.2. The sealing cone of swivel-nut type shall be of the type with a half vertical angle of 45°

1.6.2.3. The couplings can be made as swivel-nut type or as quick-connector type.

1.6.2.4. It shall be impossible to disconnect the quick-connector type without specific measures or the use of dedicated tools.

1.7. Assembly of hose and couplings

1.7.1. The construction of the couplings shall be such, that it is not necessary to peel the cover unless the reinforcement of the hose consists of corrosion-resistant material.

1.7.2. The hose assembly has to be subjected to an impulse test in compliance with standard ISO 1436.

1.7.2.1. The test has to be completed with circulating oil having a temperature of 93 °C, and a minimum pressure of 3 000 kPa.

1.7.2.2. The hose has to be subjected to 150 000 impulses.

1.7.2.3. After the impulse test the hose has to withstand the test-pressure as mentioned in paragraph 1.5.5.2 above.

1.7.3. Gas-tightness

1.7.3.1. The hose assembly (hose with couplings) has to withstand during five minutes a gas pressure of 3 000 kPa without any leakage.

- 1.8. Markings
    - 1.8.1. Every hose shall bear, at intervals of not greater than 0,5 m, the following clearly legible and indelible identification markings consisting of characters, figures or symbols.
      - 1.8.1.1. The trade name or mark of the manufacturer.
      - 1.8.1.2. The year and month of fabrication.
      - 1.8.1.3. The size and type-marking.
      - 1.8.1.4. The identification marking 'L.P.G. Class 1'.
    - 1.8.2. Every coupling shall bear the trade name or mark of the assembling manufacturer.
  2. Low pressure rubber hoses, Class 2 classification
    - 2.1. General specifications
      - 2.1.1. The hose shall be so designed as to withstand a maximum operating pressure of 450 kPa.
      - 2.1.2. The hose shall be so designed as to withstand temperatures between – 25 °C and + 125 °C. For operating temperatures exceeding the abovementioned values, the test temperatures shall be adapted.
    - 2.2. Hose construction
      - 2.2.1. The hose shall embody a smooth-bore tube and a cover of suitable synthetic material, reinforced with one or more interlayer(s).
      - 2.2.2. The reinforcing interlayer(s) has (have) to be protected by a cover against corrosion.

If for the reinforcing interlayer(s) corrosion-resistant material is used (i.e. stainless steel) a cover is not required.
      - 2.2.3. The lining and the cover shall be smooth and free from pores, holes and strange elements.

An intentionally provided puncture in the cover shall not be considered as an imperfection.
    - 2.3. Specifications and tests for the lining
      - 2.3.1. Tensile strength and elongation
        - 2.3.1.1. Tensile strength and elongation at break according to ISO 37. Tensile strength not less than 10 MPa and elongation at break not less than 250 per cent.
        - 2.3.1.2. Resistance to n-pentane according to ISO 1817 with the following conditions:
          - (a) Medium: n-pentane;
          - (b) Temperature: 23 °C (tolerance acc. to ISO 1817);
          - (c) Immersion period: 72 hours.
- Requirements:
- (a) Maximum change in volume 20 per cent;
  - (b) Maximum change in tensile strength 25 per cent;
  - (c) Maximum change in elongation at break 30 per cent.
- After storage in air with a temperature of 40 °C for a period of 48 hours the mass compared to the original value may not decrease more than 5 per cent.

2.3.1.3. Resistance to ageing according to ISO 188 with the following conditions:

(a) Temperature: 115 °C (test temperature = maximum operating temperature minus 10 °C);

(b) Exposure period: 168 hours.

Requirements:

(a) Maximum change in tensile strength 25 per cent;

(b) Maximum change in elongation at break – 30 per cent and + 10 per cent.

2.4. Specifications and test method for the cover

2.4.1.1. Tensile strength and elongation at break according to ISO 37. Tensile strength not less than 10 MPa and elongation at break not less than 250 per cent.

2.4.1.2. Resistance to n-hexane according to ISO 1817 with the following conditions:

(a) Medium: n-hexane;

(b) Temperature: 23 °C (tolerance acc. to ISO 1817);

(c) Immersion period: 72 hours.

Requirements:

(a) Maximum change in volume 30 per cent;

(b) Maximum change in tensile strength 35 per cent;

(c) Maximum change in elongation at break 35 per cent.

2.4.1.3. Resistance to ageing according to ISO 188 with the following conditions:

(a) Temperature: 115 °C (test temperature = maximum operating temperature minus 10 °C);

(b) Exposure period: 336 hours.

Requirements:

(a) Maximum change in tensile strength 25 per cent;

(b) Maximum change in elongation at break – 30 per cent and + 10 per cent.

2.4.2. Resistance to ozone

2.4.2.1. The test has to be performed in compliance with standard ISO 1431/1.

2.4.2.2. The test-pieces, which have to be stretched to an elongation of 20 per cent shall have to be exposed to air of 40 °C with an ozone concentration of 50 parts per hundred million during 120 hours.

2.4.2.3. No cracking of the test pieces is allowed.

2.5. Specifications for uncoupled hose

2.5.1. Gas-tightness (permeability)

2.5.1.1. A hose at a free length of 1 m has to be connected to a container filled with liquid propane, having a temperature of  $23 \pm 2$  °C.

2.5.1.2. The test has to be carried out in compliance with the method described in standard ISO 4080.

2.5.1.3. The leakage through the wall of the hose shall not exceed 95 cm<sup>3</sup> of vapour per metre of hose per 24 h.

## 2.5.2. Resistance at low temperature

2.5.2.1. The test has to be carried out in compliance with the method described in standard ISO 4672-1978 method B.

2.5.2.2. Test-temperature:  $-25\text{ °C} \pm 3\text{ °C}$ 

2.5.2.3. No cracking or rupture is allowed.

## 2.5.3. Bending test

2.5.3.1. An empty hose, at a length of approximately 3,5 m shall be able to withstand 3 000 times the hereafter prescribed alternating-bending-test without breaking. After the test the hose shall be capable of withstanding the test pressure as mentioned in paragraph 2.5.4.2.

## 2.5.3.2.

Figure 2 (example only)

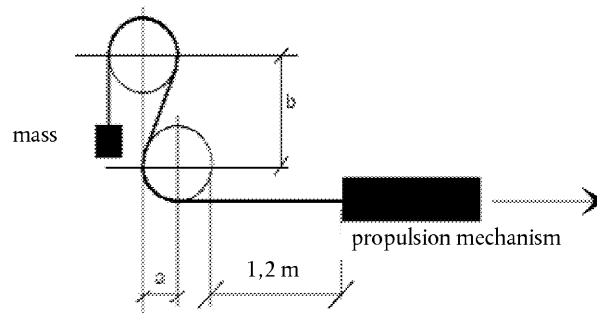

Hose inside diameter [mm]	Bending radius [mm] (Figure 2)	Distance between centres [mm] (Figure 2)	
		Vertical b	Horizontal a
up to 13	102	241	102
13 to 16	153	356	153
from 16 to 20	178	419	178

2.5.3.3. The testing machine (see Figure 2) shall consist of a steel frame, provided with two wooden wheels, with a rim-width of c.a. 130 mm.

The circumference of the wheels shall be grooved for the guidance of the hose. The radius of the wheels, measured to the bottom of the groove, shall be as indicated in paragraph 2.5.3.2 above.

The longitudinal median planes of both wheels shall be in the same vertical plane and the distance between the wheel-centres shall be in accordance with paragraph 2.5.3.2 above.

Each wheel shall be able to rotate freely round its pivot-centre.

A propulsion mechanism pulls the hose over the wheels at a speed of four complete motions per minute.

2.5.3.4. The hose shall be S-shape-like installed over the wheels (see Figure 2).

The end that runs over the upper wheel shall be furnished with a sufficient mass as to achieve a complete snuggling of the hose against the wheels. The part that runs over the lower wheel is attached to the propulsion mechanism.

The mechanism shall be so adjusted, that the hose travels a total distance of 1,2 m in both directions.

#### 2.5.4. Hydraulic test pressure and determination of the minimum burst-pressure

2.5.4.1. The test has to be carried out in compliance with the method described in standard ISO 1402.

2.5.4.2. The test pressure of 1 015 kPa shall be applied during 10 minutes, without any leakage.

2.5.4.3. The burst pressure shall not be less than 1 800 kPa.

#### 2.6. Couplings

2.6.1. The couplings shall be made from a non-corrosive material.

2.6.2. The coupling burst pressure in mounted position shall never be less than the tube or hose burst pressure.

The coupling leakage pressure in mounted position shall never be less than the tube or hose leakage pressure.

2.6.3. The couplings shall be of the crimp-fitting type.

2.6.4. The couplings can be made as swivel-nut type or as quick-connector type.

2.6.5. It shall be impossible to disconnect the quick-connector type without specific measures or the use of dedicated tools.

#### 2.7. Assembly of hose and couplings

2.7.1. If hose and couplings are not assembled by the approval holder, the approval shall consist of:

(a) Hose;

(b) Couplings; and

(c) Assembly instruction.

The assembly instruction shall be written in the language of the country to which the type of hose or couplings will be delivered, or at least in English. It shall include detailed characteristics of equipment used for the assembly operation.

2.7.2. The construction of the couplings shall be such, that it is not necessary to peel the cover unless the reinforcement of the hose consists of corrosion-resistant material.

2.7.3. The hose assembly has to be subjected to an impulse test in compliance with standard ISO 1436.

2.7.3.1. The test has to be completed with circulating oil having a temperature of 93 °C, and a minimum pressure of 1 015 kPa.

2.7.3.2. The hose has to be subjected to 150 000 impulses.

2.7.3.3. After the impulse test the hose has to withstand the test-pressure as mentioned in paragraph 2.5.4.2 above.

#### 2.7.4. Gas-tightness

2.7.4.1. The hose assembly (hose with couplings) has to withstand during five minutes a gas pressure of 1 015 kPa without any leakage.

#### 2.8. Markings

2.8.1. Every hose shall bear, at intervals of not greater than 0,5 m, the following clearly legible and indelible identification markings consisting of characters, figures or symbols.

2.8.1.1. The trade name or mark of the manufacturer.

- 2.8.1.2. The year and month of fabrication.
  - 2.8.1.3. The size and type-marking.
  - 2.8.1.4. The identification marking 'L.P.G. Class 2'.
  - 2.8.2. Every coupling shall bear the trade name or mark of the assembling manufacturer.
  3. High pressure synthetic hoses, Class 1 classification
    - 3.1. General specifications
      - 3.1.1. The purpose of this chapter is to determine the provisions regarding the approval of synthetic flexible hoses for use with LPG, having an inside diameter up to 10 mm.
      - 3.1.2. This chapter covers, in addition to general specifications and tests for synthetic hoses, also specifications and tests applicable for specific material types or a synthetic hose.
      - 3.1.3. The hose shall be so designed as to withstand a maximum operating pressure of 3 000 kPa.
      - 3.1.4. The hose shall be so designed as to withstand temperatures between – 25 °C and + 125 °C. For operating temperatures exceeding the abovementioned values, the test temperatures shall be adapted.
      - 3.1.5. The inside diameter shall be in compliance with Table 1 of standard ISO 1307.
    - 3.2. Hose construction
      - 3.2.1. The synthetic hose shall embody a thermoplastic tube and a cover of suitable thermoplastic material, oil and weatherproof, reinforced with one or more synthetic interlayer(s). If for the reinforcing interlayer(s) a corrosion-resistant material is used (i.e. stainless-steel) a cover is not required.
      - 3.2.2. The lining and the cover shall be free from pores, holes and strange elements.

An intentionally provided puncture in the cover shall not be considered as an imperfection.
    - 3.3. Specifications and tests for the lining
      - 3.3.1. Tensile strength and elongation
        - 3.3.1.1. Tensile strength and elongation at break according to ISO 37. Tensile strength not less than 20 MPa and elongation at break not less than 200 per cent.
        - 3.3.1.2. Resistance to n-pentane according to ISO 1817 with the following conditions:
          - (a) Medium: n-pentane;
          - (b) Temperature: 23 °C (tolerance acc. to ISO 1817);
          - (c) Immersion period: 72 hours.
- Requirements:
- (a) Maximum change in volume 20 per cent;
  - (b) Maximum change in tensile strength 25 per cent;
  - (c) Maximum change in elongation at break 30 per cent.

After storage in air with a temperature of 40 °C for a period of 48 hours the mass compared to the original value may not decrease more than 5 per cent.

3.3.1.3. Resistance to ageing according to ISO 188 with the following conditions:

- (a) Temperature: 115 °C (test temperature = maximum operating temperature minus 10 °C);
- (b) Exposure period: 336 hours.

Requirements:

- (a) Maximum change in tensile strength 35 per cent;
- (b) Maximum change in elongation at break – 30 per cent and + 10 per cent.

3.3.2. Tensile strength and elongation specific for polyamide 6 material

3.3.2.1. Tensile strength and elongation at break according to ISO 527-2 with the following conditions:

- (a) Specimen type: type 1 BA;
- (b) Tensile speed: 20 mm/min.,

The material has to be conditioned for at least 21 days at 23 °C and 50 per cent relative humidity prior to testing.

Requirements:

- (a) Tensile strength not less than 20 MPa;
- (b) Elongation at break not less than 50 per cent.

3.3.2.2. Resistance to n-pentane according to ISO 1817 with the following conditions:

- (a) Medium: n-pentane;
- (b) Temperature: 23 °C (tolerance according to ISO 1817);
- (c) Immersion period: 72 hours.

Requirements:

- (a) Maximum change in volume 2 per cent;
- (b) Maximum change in tensile strength 10 per cent.
- (c) Maximum change in elongation at break 10 per cent

After storage in air with a temperature of 40 °C for a period of 48 hours the mass compared to the original value may not decrease more than 5 per cent.

3.3.2.3. Resistance to ageing according to ISO 188 with the following conditions:

- (a) Temperature: 115 °C (test temperature = maximum operating temperature minus 10 °C);
- (b) Exposure period: 24 and 336 hours.

After ageing the specimens have to be conditioned at 23 °C and 50 per cent relative humidity for at least 21 days prior to carrying out the tensile test according to paragraph 3.3.2.1 above.

Requirements:

- (a) Maximum change in tensile strength 35 per cent after 336 hours ageing compared to the tensile strength of the 24 hours aged material;
- (b) Maximum change in elongation at break 25 per cent after 336 hours ageing compared to the elongation at break of the 24 hours aged material.

3.4. Specifications and test method for the cover

3.4.1.1. Tensile strength and elongation at break according to ISO 37. Tensile strength not less than 20 MPa and elongation at break not less than 250 per cent.

3.4.1.2. Resistance to n-hexane according to ISO 1817 with the following conditions:

- (a) Medium: n-hexane;
- (b) Temperature: 23 °C (tolerance according to ISO 1817);
- (c) Immersion period: 72 hours.

Requirements:

- (a) Maximum change in volume 30 per cent;
- (b) Maximum change in tensile strength 35 per cent;
- (c) Maximum change in elongation at break 35 per cent;

3.4.1.3. Resistance to ageing according to ISO 188 with the following conditions:

- (a) Temperature: 115 °C (test temperature = maximum operating temperature minus 10 °C);
- (b) Exposure period: 336 hours.

Requirements:

- (a) Maximum change in tensile strength 25 per cent;
- (b) Maximum change in elongation at break – 30 per cent and + 10 per cent.

3.4.2. Resistance to ozone

3.4.2.1. The test has to be performed in compliance with standard ISO 1431/1.

3.4.2.2. The test-pieces, which have to be stretched to an elongation of 20 per cent shall have to be exposed to air of 40 °C and a relative humidity of 50 per cent  $\pm$  10 per cent with an ozone-concentration of 50 parts per hundred million during 120 hours.

3.4.2.3. No cracking of the test pieces is allowed.

3.4.3. Specifications and test method for the cover made of polyamide 6 material

3.4.3.1. Tensile strength and elongation at break according to ISO 527-2 with the following conditions:

- (a) Specimen type: type 1 BA;
- (b) Tensile speed: 20 mm/min.

The material has to be conditioned for at least 21 days at 23 °C and 50 per cent relative humidity prior to testing.

Requirements:

- (a) Tensile strength not less than 20 MPa;
- (b) Elongation at break not less than 100 per cent.

3.4.3.2. Resistance to n-hexane according to ISO 1817 with the following conditions:

- (a) Medium: n-hexane;
- (b) Temperature: 23 °C (tolerance according to ISO 1817);
- (c) Immersion period: 72 hours.



Requirements:

- (a) Maximum change in volume 2 per cent;
- (b) Maximum change in tensile strength 10 per cent;
- (c) Maximum change in elongation at break 10 per cent.

3.4.3.3. Resistance to ageing according to ISO 188 with the following conditions:

- (a) Temperature: 115 °C (test temperature = maximum operating temperature minus 10 °C);
- (b) Exposure period: 24 and 336 hours.

After ageing the specimens have to be conditioned for at least 21 days before carrying out the tensile test according to paragraph 3.3.1.1 above.

Requirements:

- (a) Maximum change in tensile strength 20 per cent after 336 hours ageing compared to the tensile strength of the 24 hours aged material;
- (b) Maximum change in elongation at break 50 per cent after 336 hours ageing compared to the elongation at break of the 24 hours aged material.

3.5. Specifications for uncoupled hose

3.5.1. Gas-tightness (permeability)

3.5.1.1. A hose at a free length of 1 m has to be connected to a container filled with liquid propane, having a temperature of 23 °C ± 2 °C.

3.5.1.2. The test has to be carried out in compliance with the method described in standard ISO 4080.

3.5.1.3. The leakage through the wall of the hose shall not exceed 95 cm<sup>3</sup> of vapour per metre of hose per 24 h.

3.5.2. Resistance at low temperature

3.5.2.1. The test has to be carried out in compliance with the method described in standard ISO 4672 method B.

3.5.2.2. Test temperature: – 25 °C ± 3 °C.

3.5.2.3. No cracking or rupture is allowed.

3.5.3. Resistance at high temperature

3.5.3.1. A piece of hose, pressurised at 3 000 kPa, with a minimal length of 0,5 m shall be put in an oven at a temperature of 125 °C ± 2 °C during 24 hours.

3.5.3.2. No leakage is allowed.

3.5.3.3. After the test the hose shall withstand the test pressure of 6 750 kPa during 10 minutes. No leakage is allowed.

3.5.4. Bending test

3.5.4.1. An empty hose, at a length of approximately 3,5 m shall be able to withstand 3 000 times the hereafter prescribed alternating-bending-test without breaking. After the test the hose shall be capable of withstanding the test pressure as mentioned in paragraph 3.5.5.2 below.

Figure 3 (example only)

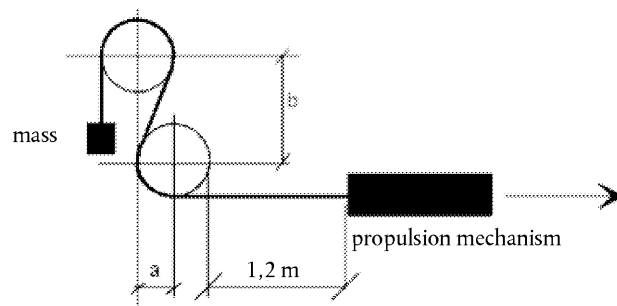

(a = 102 mm; b = 241 mm)

- 3.5.4.2. The testing machine (see Figure 3) shall consist of a steel frame, provided with two wooden wheels, with a rim-width of approximately 130 mm.

The circumference of the wheels shall be grooved for the guidance of the hose. The radius of the wheels, measured to the bottom of the groove, shall be 102 mm.

The longitudinal median planes of both wheels shall be in the same vertical plane. The distance between the wheel-centres shall be vertical 241 mm and horizontal 102 mm.

Each wheel shall be able to rotate freely round its pivot-centre.

A propulsion mechanism pulls the hose over the wheels at a speed of four complete motions per minute.

- 3.5.4.3. The hose shall be S-shape-like installed over the wheels (see Figure 3).

The end, that runs over the upper wheel, shall be furnished with a sufficient mass as to achieve a complete snuggling of the hose against the wheels. The part that runs over the lower wheel is attached to the propulsion mechanism.

The mechanism shall be so adjusted, that the hose travels a total distance of 1,2 m in both directions.

- 3.5.5. Hydraulic test pressure and determination of the minimum burst-pressure

3.5.5.1. The test has to be carried out in compliance with the method described in standard ISO 1402.

3.5.5.2. The test pressure of 6 750 kPa shall be applied during 10 minutes, without any leakage.

3.5.5.3. The burst pressure shall not be less than 10 000 kPa.

### 3.6. Couplings

3.6.1. The couplings shall be made from steel or brass and the surface shall be corrosion-resistant.

3.6.2. The couplings shall be of the crimp-fitting type and made up of a hose-coupling or banjo bolt. The sealing shall be resistant to LPG and comply with paragraph 3.3.1.2 above.

3.6.3. The banjo bolt shall comply with DIN 7643.

### 3.7. Assembly of hose and couplings

3.7.1. The hose assembly has to be subjected to an impulse test in compliance with standard ISO 1436.

3.7.1.1. The test has to be completed with circulating oil having a temperature of 93 °C, and a minimum pressure of 3 000 kPa.

- 3.7.1.2. The hose has to be subjected to 150 000 impulses.
- 3.7.1.3. After the impulse-test the hose has to withstand the test pressure as mentioned in paragraph 3.5.5.2 above.
- 3.7.2. Gas-tightness
  - 3.7.2.1. The hose assembly (hose with couplings) has to withstand during five minutes a gas pressure of 3 000 kPa without any leakage.
- 3.8. Markings
  - 3.8.1. Every hose shall bear, at intervals of not greater than 0,5 m, the following clearly legible and indelible identification markings consisting of characters, figures or symbols.
    - 3.8.1.1. The trade name or mark of the manufacturer.
    - 3.8.1.2. The year and month of fabrication.
    - 3.8.1.3. The size and type-marking.
    - 3.8.1.4. The identification marking 'L.P.G. Class 1'.
  - 3.8.2. Every coupling shall bear the trade name or mark of the assembling manufacturer.
- 4. High pressure synthetic hoses, Class 0 classification
  - 4.1. General specifications
    - 4.1.1. The purpose of this chapter is to determine the provisions regarding the approval of synthetic flexible hoses for use with LPG, having an inside diameter up to 10 mm.
    - 4.1.2. This chapter covers, in addition to general specifications and tests for synthetic hoses, also specifications and tests applicable for specific material types or a synthetic hose.
    - 4.1.3. The hose shall be so designed as to withstand a maximum operating pressure of WP.
    - 4.1.4. The hose shall be so designed as to withstand temperatures between – 25 °C and + 125 °C. For operating temperatures exceeding the abovementioned values, the test temperatures shall be adapted.
    - 4.1.5. The inside diameter shall be in compliance with Table 1 of standard ISO 1307.
  - 4.2. Hose construction
    - 4.2.1. The synthetic hose shall embody a thermoplastic tube and a cover of suitable thermoplastic material, oil and weatherproof, reinforced with one or more synthetic interlayer(s). If for the reinforcing interlayer(s) a corrosion-resistant material is used (i.e. stainless-steel) a cover is not required.
    - 4.2.2. The lining and the cover shall be free from pores, holes and strange elements.

An intentionally provided puncture in the cover shall not be considered as an imperfection.
  - 4.3. Specifications and tests for the lining
    - 4.3.1. Tensile strength and elongation
      - 4.3.1.1. Tensile strength and elongation at break according to ISO 37. Tensile strength not less than 20 MPa and elongation at break not less than 200 per cent.

4.3.1.2. Resistance to n-pentane according to ISO 1817 with the following conditions:

- (a) Medium: n-pentane;
- (b) Temperature: 23 °C (tolerance acc. to ISO 1817);
- (c) Immersion period: 72 hours.

Requirements:

- (a) Maximum change in volume 20 per cent;
- (b) Maximum change in tensile strength 25 per cent;
- (c) Maximum change in elongation at break 30 per cent.

After storage in air with a temperature of 40 °C for a period of 48 hours the mass compared to the original value may not decrease more than 5 per cent.

4.3.1.3. Resistance to ageing according to ISO 188 with the following conditions:

- (a) Temperature: 115 °C (test temperature = maximum operating temperature minus 10 °C);
- (b) Exposure period: 336 hours.

Requirements:

- (a) Maximum change in tensile strength 35 per cent;
- (b) Maximum change in elongation at break – 30 per cent and + 10 per cent.

4.3.2. Tensile strength and elongation specific for polyamide 6 material

4.3.2.1. Tensile strength and elongation at break according to ISO 527-2 with the following conditions:

- (a) Specimen type: type 1 BA;
- (b) Tensile speed: 20 mm/min.

The material has to be conditioned for at least 21 days at 23 °C and 50 per cent relative humidity prior to testing.

Requirements:

- (a) Tensile strength not less than 20 MPa;
- (b) Elongation at break not less than 50 per cent.

4.3.2.2. Resistance to n-pentane according to ISO 1817 with the following conditions:

- (a) Medium: n-pentane;
- (b) Temperature: 23 °C (tolerance according to ISO 1817);
- (c) Immersion period: 72 hours.

Requirements:

- (a) Maximum change in volume 2 per cent;
- (b) Maximum change in tensile strength 10 per cent;
- (c) Maximum change in elongation at break 10 per cent.

After storage in air with a temperature of 40 °C for a period of 48 hours the mass compared to the original value may not decrease more than 5 per cent.

4.3.2.3. Resistance to ageing according to ISO 188 with the following conditions:

- (a) Temperature: 115 °C (test temperature = maximum operating temperature minus 10 °C);
- (b) Exposure period: 24 and 336 hours.

After ageing the specimens have to be conditioned at 23 °C and 50 per cent relative humidity for at least 21 days prior to carrying out the tensile test according to paragraph 4.3.2.1 above.

Requirements:

- (a) Maximum change in tensile strength 35 per cent after 336 hours ageing compared to the tensile strength of the 24 hours aged material;
- (b) Maximum change in elongation at break 25 per cent after 336 hours ageing compared to the elongation at break of the 24 hours aged material.

4.4. Specifications and test method for the cover

4.4.1.1. Tensile strength and elongation at break according to ISO 37. Tensile strength not less than 20 MPa and elongation at break not less than 250 per cent.

4.4.1.2. Resistance to n-hexane according to ISO 1817 with the following conditions:

- (a) Medium: n-hexane;
- (b) Temperature: 23 °C (tolerance according to ISO 1817);
- (c) Immersion period: 72 hours.

Requirements:

- (a) Maximum change in volume 30 per cent;
- (b) Maximum change in tensile strength 35 per cent;
- (c) Maximum change in elongation at break 35 per cent.

4.4.1.3. Resistance to ageing according to ISO 188 with the following conditions:

- (a) Temperature: 115 °C (test temperature = maximum operating temperature minus 10 °C);
- (b) Exposure period: 336 hours.

Requirements:

- (a) Maximum change in tensile strength 25 per cent;
- (b) Maximum change in elongation at break – 30 per cent and + 10 per cent.

4.4.2. Resistance to ozone

4.4.2.1. The test shall be performed in compliance with standard ISO 1431/1 -1:2004/Amd 1:2009.

4.4.2.2. The test-pieces, which have to be stretched to an elongation of 20 per cent shall be exposed to air of 40 °C and a relative humidity of 50 per cent  $\pm$  10 per cent with an ozone concentration of 50 parts per hundred million during 120 hours.

4.4.2.3. Cracking of the test pieces is not allowed.

4.4.3. Specifications and test method for the cover made of polyamide 6 material

4.4.3.1. Tensile strength and elongation at break according to ISO 527-2 with the following conditions:

- (a) Specimen type: type 1 BA;
- (b) Tensile speed: 20 mm/min.

The material has to be conditioned for at least 21 days at 23 °C and 50 per cent relative humidity prior to testing.

Requirements:

- (a) Tensile strength not less than 20 MPa;
- (b) Elongation at break not less than 100 per cent.

4.4.3.2. Resistance to n-hexane according to ISO 1817 with the following conditions:

- (a) Medium: n-hexane;
- (b) Temperature: 23 °C (tolerance according to ISO 1817);
- (c) Immersion period: 72 hours.

Requirements:

- (a) Maximum change in volume 2 per cent;
- (b) Maximum change in tensile strength 10 per cent;
- (c) Maximum change in elongation at break 10 per cent.

4.4.3.3. Resistance to ageing according to ISO 188 with the following conditions:

- (a) Temperature: 115 °C (test temperature = maximum operating temperature minus 10 °C);
- (b) Exposure period: 24 and 336 hours.

After ageing the specimens have to be conditioned for at least 21 days before carrying out the tensile test according to paragraph 4.3.1.1 above.

Requirements:

- (a) Maximum change in tensile strength 20 per cent after 336 hours ageing compared to the tensile strength of the 24 hours aged material;
- (b) Maximum change in elongation at break 50 per cent after 336 hours ageing compared to the elongation at break of the 24 hours aged material.

4.5. Specifications for uncoupled hose

4.5.1. Gas-tightness (permeability)

4.5.1.1. A hose at a free length of 1 m has to be connected to a container filled with liquid propane, having a temperature of 23 °C ± 2 °C.

4.5.1.2. The test has to be carried out in compliance with the method described in standard ISO 4080.

4.5.1.3. The leakage through the wall of the hose shall not exceed 95 cm<sup>3</sup> of vapour per metre of hose per 24 h. Leakage of the liquid LPG shall be measured and be lower than the gaseous leakage (95 cm<sup>3</sup>/hour).

4.5.2. Resistance at low temperature

4.5.2.1. The test has to be carried out in compliance with the method described in standard ISO 4672 method B.

4.5.2.2. Test temperature: - 25 °C ± 3 °C.

4.5.2.3. No cracking or rupture is allowed.

4.5.3. Resistance at high temperature

4.5.3.1. A piece of hose, pressurised at WP, with a minimal length of 0,5 m shall be put in an oven at a temperature of 125 °C ± 2 °C during 24 hours.

4.5.3.2. No leakage is allowed.

4.5.3.3. After the test the hose shall withstand the test pressure of 2,25 WP during 10 minutes. No leakage is allowed.

4.5.4. Bending test

4.5.4.1. An empty hose, at a length of approximately 3,5 m shall be able to withstand 3 000 times the hereafter prescribed alternating-bending-test without breaking.

After the test the hose shall be capable of withstanding the test pressure as mentioned in paragraph 4.5.5.2 below.

Figure 4 (example only)

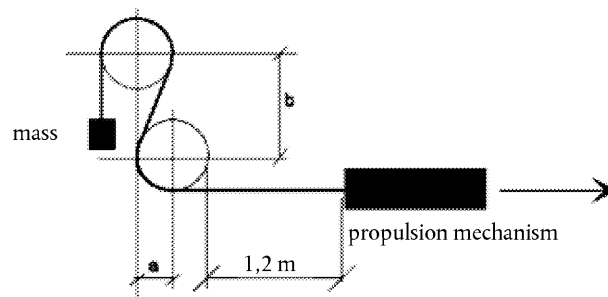

(a = 102 mm; b = 241 mm)

4.5.4.2. The testing machine (see Figure 4) shall consist of a steel frame, provided with two wooden wheels, with a rim-width of approximately 130 mm.

The circumference of the wheels shall be grooved for the guidance of the hose. The radius of the wheels, measured to the bottom of the groove, shall be 102 mm.

The longitudinal median planes of both wheels shall be in the same vertical plane. The distance between the wheel-centres shall be vertical 241 mm and horizontal 102 mm.

Each wheel shall be able to rotate freely round its pivot-centre.

A propulsion mechanism pulls the hose over the wheels at a speed of four complete motions per minute.

4.5.4.3. The hose shall be S-shape-like installed over the wheels (see Figure 4).

The end, which runs over the upper wheel, shall be furnished with a sufficient mass as to achieve a complete snuggling of the hose against the wheels. The part that runs over the lower wheel is attached to the propulsion mechanism.

The mechanism shall be so adjusted, that the hose travels a total distance of 1,2 m in both directions.

4.5.5. Hydraulic test pressure and determination of the minimum burst-pressure

4.5.5.1. The test has to be carried out in compliance with the method described in standard ISO 1402.

4.5.5.2. The test pressure of 2,25 WP shall be applied during 10 minutes, without any leakage.

4.5.5.3. The burst pressure shall not be less than 10 000 kPa and at least 2,25 WP.

4.6. Couplings

4.6.1. The couplings shall be made from steel or brass and the surface shall be corrosion-resistant.

- 4.6.2. The couplings shall be of the crimp-fitting type and made up of a hose-coupling or banjo bolt. The sealing shall be resistant to LPG and comply with paragraph 4.3.1.2 above.
  - 4.6.3. The banjo bolt shall comply with DIN 7643.
  - 4.7. Assembly of hose and couplings
    - 4.7.1. The hose assembly has to be subjected to an impulse test in compliance with standard ISO 1436.
      - 4.7.1.1. The test has to be completed with circulating oil having a temperature of 93 °C, and a minimum pressure of WP.
      - 4.7.1.2. The hose has to be subjected to 150 000 impulses.
      - 4.7.1.3. After the impulse-test the hose has to withstand the test pressure as mentioned in paragraph 4.5.5.2.
    - 4.7.2. Gas-tightness
      - 4.7.2.1. The hose assembly (hose with couplings) has to withstand during five minutes a gas pressure of 1,5 WP without any leakage.
  - 4.8. Markings
    - 4.8.1. Every hose shall bear, at intervals of not greater than 0,5 m, the following clearly legible and indelible identification markings consisting of characters, figures or symbols.
      - 4.8.1.1. The trade name or mark of the manufacturer.
      - 4.8.1.2. The year and month of fabrication.
      - 4.8.1.3. The size and type-marking.
      - 4.8.1.4. The identification marking 'L.P.G. Class 0'.
    - 4.8.2. Every coupling shall bear the trade name or mark of the assembling manufacturer.
-



## ANNEX 9

**PROVISIONS REGARDING THE APPROVAL OF THE FILLING UNIT**

1. Definition: See paragraph 2.16 of this Regulation.
2. Component classification (according to Figure 1, para. 2 of this Regulation):  
 Filling unit: Class 3  
 Non-return valve: Class 3
3. Classification pressure: 3 000 kPa.
4. Design temperatures:  
 – 20 °C to 65 °C  
  
 For temperatures exceeding the abovementioned values, special tests conditions are applicable.
5. General design rules:  
 Paragraph 6.15.2, Provisions regarding the electrical insulation.  
 Paragraph 6.15.10, Provisions regarding the filling unit.
6. Applicable test procedures:
 

Overpressure test	Annex 15, para. 4
External leakage	Annex 15, para. 5
High temperature	Annex 15, para. 6
Low temperature	Annex 15, para. 7
Seat leakage test	Annex 15, para. 8
Endurance (with 6 000 operation cycles)	Annex 15, para. 9
LPG compatibility	Annex 15, para. 11 (**)
Corrosion resistance	Annex 15, para. 12 (*)
Resistance to dry heat	Annex 15, para. 13
Ozone ageing	Annex 15, para. 14
Creep	Annex 15, para. 15 (**)
Temperature cycle	Annex 15, para. 16 (**)
Impact test	paragraph 7 of this annex

## 7. Impact test requirements for the Euro filling unit

## 7.1. General requirements

The filling unit shall be subjected to an impact test of 10 J.

## 7.2. Test procedure

A hardened steel mass of 1 kg shall be dropped from a height of 1 m so as to deliver the impact velocity 4,4 m/s. This shall be achieved by mounting the mass in a pendulum.

The filling unit shall be installed horizontally on a solid object. The impact of the mass shall be on the centre of the protruding part of the filling unit.

### 7.3. Test interpretation

The filling unit shall comply with the external leak test and seat leak test at ambient temperature.

### 7.4. Re-testing

If the filling unit fails the test, 2 samples of the same component shall be submitted to the impact test. If both samples pass the test, the first test shall be ignored. In the event where one or both fail the re-test, the component shall not be approved.

Remarks:

- (a) The overpressure test has to be performed on each non-return valve.
- (b) The endurance test shall be carried out with a nozzle specifically intended for the filling unit under test. 6 000 cycles shall be applied according to the following procedure:
  - (i) Connect the nozzle to the connector and open the filling unit system;
  - (ii) Leave in open situation for at least 3 seconds;
  - (iii) Close the filling unit and disconnect the nozzle.

Figure 1

#### Connecting area of the bayonet filling unit

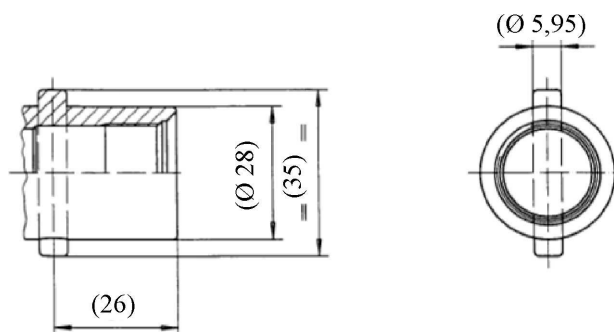

Figure 2

#### Connecting area of the Dish filling unit

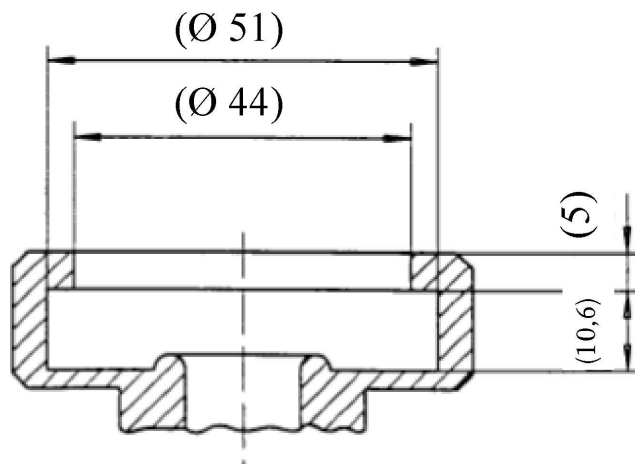

Figure 3

## Connecting area of the light vehicle Euro filling unit

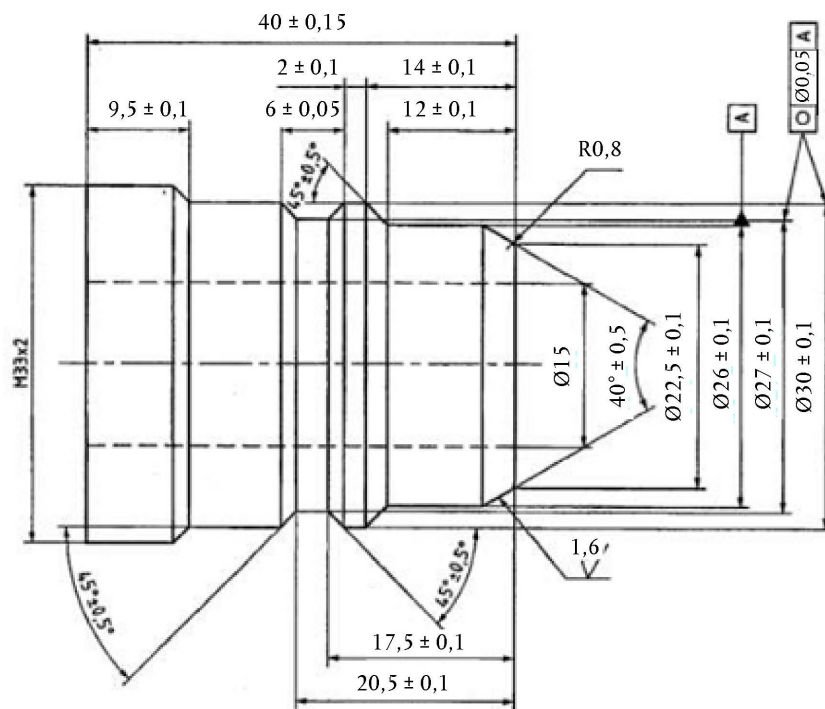
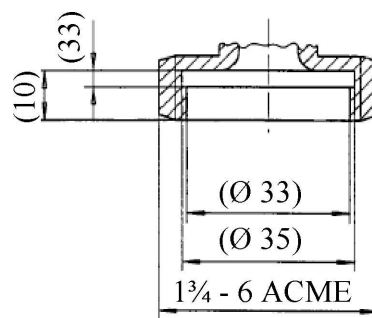

Figure 4

## Connecting area of the ACME filling unit





## ANNEX 10

## PROVISIONS REGARDING THE APPROVAL OF LPG CONTAINERS

The meaning of symbols and terms used in this annex

- $P_h$  = hydraulic test pressure in kPa;
- $P_r$  = container bursting pressure measured in the bursting test, in kPa;
- $R_e$  = minimum yield stress in N/mm<sup>2</sup> guaranteed by the material standard;
- $R_m$  = minimum tensile strength in N/mm<sup>2</sup> guaranteed by the material standard
- $R_{mt}$  = actual tensile strength, in N/mm<sup>2</sup>;
- $a$  = calculated minimum thickness of the cylindrical shell wall, in mm;
- $b$  = calculated minimum thickness of dished ends, in mm;
- $D$  = nominal outside diameter of the container, in mm;
- $R$  = inside radius of the dished end of the standard cylindrical container, in mm;
- $r$  = inside knuckle of the dished end of the standard cylindrical container, in mm;
- $H$  = outside height of dished part of container end, in mm;
- $h$  = height of cylindrical part of dished end, in mm;
- $L$  = length of container's stress-resistant shell, in mm;
- $A$  = elongation value (per cent) of parent material;
- $V_0$  = initial volume of the container at the moment when the pressure is increased in the burst test, in dm<sup>3</sup>;
- $V$  = final volume of the container on bursting, in dm<sup>3</sup>;
- $g$  = gravity, in m/s<sup>2</sup>;
- $c$  = shape factor;
- $Z$  = stress reduction factor.

1. Technical requirements

1.1. Cylinders covered by this annex are as follows:

LPG-1 Metal containers

LPG-4 All-Composite containers

1.2. Dimensions

For all dimensions without indication of tolerances, general tolerances of EN 22768-1 shall apply.

1.3. Materials

1.3.1. The material used for the manufacture of the stress-resistant container shells shall be steel as specified in Euronorm EN 10120 (however, other materials may be used provided that the container has the same safety characteristics, to be certified by the Type Approval Authorities granting type approval).

- 1.3.2. The parent material refers to the material in the state before any specific transformation with regards to the manufacturing process has been carried out.
- 1.3.3. All components of the container body and all the parts welded thereto shall be made of mutually compatible materials.
- 1.3.4. The filler materials shall be compatible with the parent material so as to form welds with properties equivalent to those specified for the parent material (EN 288-39).
- 1.3.5. The container manufacturer shall obtain and provide:
- (a) For metal containers: chemical cast analysis certificates;
  - (b) For all-composite containers: chemical resistance analysis certificates related to tests performed according to the requirements of Appendix 6;
  - (c) Mechanical properties of the material in respect of the steels or other materials applied for the construction of the parts subject to pressure.
- 1.3.6. The inspection authority shall have the opportunity to make independent analyses. These analyses shall be carried out either on specimens taken from the materials as supplied to the container manufacturer or on the finished containers.
- 1.3.7. The manufacturer shall make available to the inspection authority the results of metallurgical and mechanical tests and analyses of parent and filler materials carried out on welds and shall also provide it with a description of the welding methods and processes which can be regarded as representative of the welds made during production.
- 1.4. Design temperatures and pressures
- 1.4.1. Design temperature
- The design operating temperature of the container shall be from  $-20\text{ °C}$  to  $65\text{ °C}$ . For extreme operating temperatures exceeding the abovementioned temperatures special test conditions are applicable which shall be agreed upon with the competent authority.
- 1.4.2. Design pressure
- The design operating pressure of the container shall be: 3 000 kPa.
- 1.5. The heat treatment procedures, on metal containers only, shall be according to the following requirements:
- 1.5.1. The heat treatment shall be carried out on the parts or on the complete container.
- 1.5.2. Those parts of a container having been deformed by more than 5 per cent shall be submitted to the following heat treatment: normalise.
- 1.5.3. Containers with a wall thickness  $\geq 5\text{ mm}$  shall be submitted to the following heat treatment:
- 1.5.3.1. Hot-rolled and normalised material: stress relieve or normalise;
  - 1.5.3.2. Material of a different kind: normalise.
- 1.5.4. The manufacturer shall submit the procedure for the heat treatment used.
- 1.5.5. Localised heat treatment of a completed container is not permitted.

1.6. Calculation of the parts under pressure

1.6.1. Calculation of the parts under pressure for metal containers.

1.6.1.1. The wall thickness of the cylindrical shell of the containers shall not be less than that calculated by the formula:

1.6.1.1.1. Containers without longitudinal welds:

$$a = \frac{P_h \cdot D}{2\,000 \frac{R_e}{4/3} + P_h} = \frac{P_h \cdot D}{1\,500R_e + P_h}$$

1.6.1.1.2. Containers with longitudinal welds:

$$a = \frac{P_h \cdot D}{2\,000 \frac{R_e}{4/3} \cdot z + P_h} = \frac{P_h \cdot D}{1\,500R_e \cdot z + P_h}$$

(a)  $z = 0,85$  where the manufacturer radiographs each weld intersection and 100 mm of the adjacent longitudinal weld and 50 mm (25 mm each side of the intersection) of the adjacent circumferential weld.

This test has to be performed per machine at the beginning and end of each work shift period from continuous production.

(b)  $z = 1$  where each weld intersection and 100 mm of the adjacent longitudinal weld and 50 mm (25 mm each side of the intersection) of the adjacent circumferential weld is spot radiographed.

This test has to be performed at 10 per cent of the container production: the containers to be tested are chosen randomly. Should these radiograph tests reveal unacceptable defects, as defined in paragraph 2.4.1.4 of this annex, all the necessary steps shall be taken to examine the production run in question and eliminate the defects.

1.6.1.2. Dimensions and calculations of ends (see figures in Appendix 4 to this annex).

1.6.1.2.1. The container ends shall be in one piece, shall encave to the pressure and shall have either a torispherical or an elliptical form (examples are given in Appendix 5 of this annex).

1.6.1.2.2. The container ends shall fulfil the following conditions:

Torispherical ends

simultaneous limits:  $0,003 D \leq b \leq 0,08 D$

$r \geq 0,1 D$

$R \leq D$

$H \geq 0,18 D$

$r \geq 2 b$

$h \geq 4 b$

$h \leq 0,15 D$  (not applicable for containers as shown in Appendix 2 to this annex, Figure 2a)

Elliptical ends

simultaneous limits:  $0,003 D \leq b \leq 0,08 D$

$H \geq 0,18 D$

$$h \geq 4 b$$

$$h \leq 0,15 D \text{ (not applicable for containers as shown in Appendix 2 to this annex, Figure 2a)}$$

- 1.6.1.2.3. The thickness of these barrelled ends shall not be *in toto* less than the figure calculated by means of the following formula:

$$b = \frac{P_h \cdot D}{1\ 500R_e} C$$

The shape factor C to be used for full ends is given in the table and in the graphs contained in Appendix 4 to this annex.

The wall thickness of the cylindrical edge of the ends may not be less or differ more than 15 per cent from the smallest wall thickness of the shell.

- 1.6.1.3. The nominal wall thickness of the cylindrical part and of the barrelled end may not, under any circumstances; be less than:

$$\frac{D}{250} + 1 \text{ mm}$$

with a minimum of 1,5 mm.

- 1.6.1.4. The shell of the container may be made up of one, two or three parts. When the shell is made up from two or three parts, the longitudinal welds shall be shifted/rotated with a minimum of 10 times the thickness of the container wall ( $10 \times a$ ). The ends shall be in one piece and convex.

- 1.6.2. Calculation of the parts under pressure for all-composite containers

The stresses in the container shall be calculated for each container type. The pressures used for these calculations shall be the design pressure and burst test pressure. The calculations shall use suitable analysis techniques to establish stress distribution throughout the container.

- 1.7. Construction and workmanship

- 1.7.1. General requirements

- 1.7.1.1. The manufacturer shall demonstrate by having a suitable quality control system that he has and maintains the manufacturing facilities and processes to ensure that containers produced satisfy the requirements of this annex.

- 1.7.1.2. The manufacturer shall ensure through adequate supervision that the parent materials and pressed parts used to manufacture the containers are free from defects likely to jeopardise the safe use of the containers.

- 1.7.2. Parts subjected to pressure

- 1.7.2.1. The manufacturer shall describe the welding methods and processes used and indicate the inspections carried out during production.

- 1.7.2.2. Technical welding requirements

The butt welds shall be executed by an automatic welding process.

The butt welds on the stress-resistant shell may not be located in any area where there are changes of profile.

Angle welds may not be superimposed on butt welds and shall be at least 10 mm away from them.



Welds joining parts making up the shell of the container shall satisfy the following conditions (see figures given as examples in Appendix 1 to this annex):

Longitudinal weld: this weld is executed in the form of a butt weld on the full section of the material of the wall;

Circumferential weld: this weld is executed in the form of a butt weld on the full section of the material of the wall. A joggle weld is considered to be a special type of butt weld;

Welds of the studded valve plate or ring shall be carried out according to Appendix 1, Figure 3.

A weld fixing the collar or supports to the container shall be either a butt or angle weld.

Welded mounting supports shall be welded in the circumferential way. The welds shall be strong enough to withstand vibration, braking actions and outside forces of at least 30 g in all directions.

In this case of butt welds, the misalignment of the joint faces may not exceed one-fifth of the thickness of the walls ( $1/5 a$ ).

#### 1.7.2.3. Inspection of welds

The manufacturer shall ensure that the welds show continuous penetration without any deviation of the weld seam, and that they are free from defects likely to jeopardise the safe use of the container.

For containers in two pieces, a radiographical test has to be performed on the circumferential butt welds over 100 mm, with the exception of the welds in conformity with joggle weld on page 1 of Appendix 1 to this annex. On one container selected at the beginning and end of each shift period from continuous production and, in the event of production being interrupted for a period of more than 12 hours, the first container welded should also be radiographed.

#### 1.7.2.4. Out-of-roundness

The out-of-roundness of the cylindrical shell of the container shall be limited so that the difference between the maximum and minimum outside diameter of the same cross-section is not more than 1 per cent of the average of those diameters.

#### 1.7.3. Fittings

1.7.3.1. The supports shall be manufactured and attached to the container body in such a way as not to cause dangerous concentrations of stresses or be conducive to the collection of water.

1.7.3.2. The base of the container shall be sufficiently strong and made of metal compatible with the type of steel used for the container. The form of the base shall give the container sufficient stability.

The top edge of the base shall be welded to the container in such a way as not to be conducive to the collection of water nor to allow water to penetrate between the base and the container.

1.7.3.3. A reference mark shall be affixed on the containers to ensure their correct installation.

1.7.3.4. Where fitted, identification plates shall be fixed on to the stress resistant shell and shall not be removable. All the necessary corrosion prevention measures shall be taken.

1.7.3.5. The container shall have provisions to mount a gas-tight housing or kind of protection device over the container accessories.

1.7.3.6. Any other material, however, may be used for the manufacture of the supports, provided that its strength is assured and that all risk of the container end corroding is eliminated.

## 1.7.4. Fire protection

1.7.4.1. A container representative of the type of container, all accessories fitted on it and any added insulation or protective material shall be covered by a bonfire test as specified in paragraph 2.6 of this annex.

## 2. Tests

Tables 1 and 2 below give an overview of the tests to be performed on the LPG containers on prototypes as well as during the production process according to their nature. All tests shall be performed at ambient temperature of  $20\text{ °C} \pm 5\text{ °C}$ , unless otherwise stated.

Table 1

**Overview of tests to be performed on metal containers**

Test to be performed	Production Batch tests	Number of containers to be tested for type approval	Test description
Tensile test	1 per batch	2 <sup>(1)</sup>	See para. 2.1.2.2
Bend test	1 per batch	2 <sup>(1)</sup>	See para. 2.1.2.3
Burst test		2	See para. 2.2
Hydraulic test	Each container	100 %	See para. 2.3
Bonfire test		1	See para. 2.6
Radiographic examination	1 per batch	100 %	See para. 2.4.1
Macroscopic examination	1 per batch	2 <sup>(1)</sup>	See para. 2.4.2
Inspection of welds	1 per batch	100 %	See para. 1.7.2.3
Visual inspection of the parts of the container	1 per batch	100 %	

<sup>(1)</sup> These test pieces can be taken from one container.

Note 1: 6 containers shall be submitted for type approval.

Note 2: On one of these prototypes the volume of the container and the wall thickness of each part of the container shall be determined.

Table 2

**Overview of tests to be performed on all-composite containers**

Test to be performed	Production Batch tests	Number of containers to be tested for type approval	Test description
Burst test	1 per batch	3	See para. 2.2
Hydraulic test	Each container	All containers	See para. 2.3

Test to be performed	Production Batch tests	Number of containers to be tested for type approval	Test description
Ambient temperature pressure cycling test	1 per 5 batches	3	See para. 2.3.6.1
High temperature pressure cycling test		1	See para. 2.3.6.2
External leak test		1	See para. 2.3.6.3
Permeation test		1	See para. 2.3.6.4
LPG cycling test		1	See para. 2.3.6.5
High temperature creep test		1	See para. 2.3.6.6
Bonfire test		1	See para. 2.6
Impact test		1	See para. 2.7
Drop test		1	See para. 2.8
Boss torque test		1	See para. 2.9
Acid environment test		1	See para. 2.10
Ultra-violet radiation test		1	See para. 2.11

## 2.1. Mechanical tests

### 2.1.1. General requirements

#### 2.1.1.1. Frequency of the mechanical tests

- 2.1.1.1.1. The frequency of the tests for metal containers shall be: 1 container from each batch during production and for type testing, see Table 1.

Test pieces which are not flat shall be flattened by a cold process.

In test pieces containing a weld, the weld shall be machined to trim the surplus.

Metal containers shall be subjected to the tests as described in Table 1.

Test pieces from containers with one circumferential weld only (two sections) shall be taken from the places shown in Appendix 2, Figure 1.

Test pieces from containers with longitudinal and circumferential welds (three or more sections) shall be taken from the places shown in Appendix 2, Figure 2.

#### 2.1.1.1.2. The frequency of the tests for all-composite containers shall be:

- (a) During production: 1 container from each batch;
- (b) For type testing, see Table 2.

- 2.1.1.2. All the mechanical tests for checking the properties of the parent metal and welds of the stress-resistant shells of the container are carried out on test pieces taken from finished containers.
- 2.1.2. Types of tests and evaluation of test results
- 2.1.2.1. Each sample container is subjected to the following tests:
- 2.1.2.1.1. Containers with longitudinal and circumferential welds (three sections) on test-pieces taken from the places shown in Figure 1 of Appendix 2 to this annex:
- (a) One tensile test on parent material; the test piece to be taken in the longitudinal direction (if this is not possible, it may be taken in a circumferential direction);
  - (b) One tensile test on parent material of the bottom;
  - (c) One tensile test perpendicular to the longitudinal weld;
  - (d) One tensile test perpendicular to the circumferential weld;
  - (e) One bend test on the longitudinal weld, the inner surface in tension;
  - (f) One bend test on the longitudinal weld, the outer surface in tension;
  - (g) One bend test on the circumferential weld, the inner surface in tension;
  - (h) One bend test on the circumferential weld, the outer surface in tension; and
  - (i) One macroscopic test of a welded section;
- (m1, m2) A minimum of two macroscopic tests of valve boss/plate sections in case of the sidewall mounted valves referred to in paragraph 2.4.2 below.
- 2.1.2.1.2. Containers with circumferential welds only (two sections) on test-pieces taken from the places shown in Figures 2a and 2b of Appendix 2 to this annex:
- The tests as specified in paragraph 2.1.2.1.1 above with the exception of (c), (e) and (f) which are not applicable. The test-piece for the tensile test on parent material shall be taken from (a) or (b) as mentioned in paragraph 2.1.2.1.1 above.
- 2.1.2.1.3. Test-pieces which are not sufficiently flat shall be flattened by cold pressing.
- 2.1.2.1.4. In all test pieces containing a weld, the weld is machined to trim the surplus.
- 2.1.2.2. Tensile test
- 2.1.2.2.1. Tensile test on parent metal
- 2.1.2.2.1.1. The tensile test shall be carried out in accordance with Euronorms EN 876, EN 895 and EN 10002-1.
- 2.1.2.2.1.2. The values determined for yield stress, tensile strength and elongation after break shall comply with the characteristics of the metal as required in paragraph 1.3 of this annex.
- 2.1.2.2.2. Tensile test on welds
- 2.1.2.2.2.1. This tensile test perpendicular to the weld shall be carried out on a test-piece having a reduced cross-section 25 mm in width for a length extending up to 15 mm beyond the edges of the weld, as shown in Figure 2 of Appendix 3 to this annex.

Beyond this central part the width of the test-piece shall increase progressively.

2.1.2.2.2.2. The tensile strength value obtained shall meet the minimum levels required by EN 10120.

2.1.2.3. Bend test

2.1.2.3.1. The bend test shall be carried out in accordance with standards ISO 7438:2005 and ISO 7799:1985 and ISO 5173:2009 + Amd 1:2011 for welded parts. The bend tests shall be carried out on the inner surface in tension and the outer surface in tension.

2.1.2.3.2. Cracks shall not appear in the test-piece when it is bent round a mandrel as long as the inside edges are separated by a distance not greater than the diameter of the mandrel +3a (see Figure 1 of Appendix 3 to this annex).

2.1.2.3.3. The ratio (n) between the diameter of the mandrel and the thickness of the test piece shall not exceed the values given in the following table:

Actual tensile strength $R_t$ in (N/mm <sup>2</sup> )	Value (n)
Up to 440 inclusive	2
Above 440 to 520 inclusive	3
Above 520	4

2.1.2.4. Retesting for the tensile and bend tests

2.1.2.4.1. Retesting is permitted for the tensile and bend test. A second test shall consist of two test pieces taken from the same container.

If the results of these tests are satisfactory, the first test shall be ignored.

In the event where one or both of the retests fail to meet the requirements, the batch shall be rejected.

2.2. Burst test under hydraulic pressure

2.2.1. Test conditions

Containers subjected to this test shall bear the inscriptions which it is proposed to affix on the section of the container subjected to pressure,

2.2.1.1. The burst test under hydraulic pressure shall be carried out with equipment which enables the pressure to be increased at an even rate, until the container bursts and the change in pressure over time to be recorded. The maximum flow rate during the test should not exceed 3 per cent of the capacity of the container per minute.

2.2.2. Test interpretation

2.2.2.1. The criteria adopted for the interpretation of the burst test are as follows:

2.2.2.1.1. Volumetric expansion of the metal container; it equals: volume of water used between the time when the pressure starts to rise and the time of bursting;

2.2.2.1.2. Examination of the tear and the shape of its edges;

2.2.2.1.3. Bursting pressure.

### 2.2.3. Test acceptance conditions

2.2.3.1. The measured bursting pressure ( $P_b$ ) shall not under any circumstances be less than  $2,25 \times 3\,000 = 6\,750$  kPa.

2.2.3.2. The specific change in the volume of the metal container at the time of bursting shall not be less than:

20 per cent if the length of the metal container is greater than the diameter;

17 per cent if the length of the metal container is equal to or less than the diameter.

8 per cent in the case of a special metal container as shown in Appendix 5 to this annex, page 1, Figures A, B and C.

2.2.3.3. The burst test shall not cause any fragmentation of the container.

2.2.3.3.1. The main fracture shall not show any brittleness, i.e. the edges of the fracture shall not be radial but shall be at an angle to a diametrical plane and display a reduction of area throughout their thickness.

2.2.3.3.2. For metal containers the fracture shall not reveal an inherent defect in the metal. The weld shall be at least as strong as the original metal but preferably stronger.

For all-composite containers, the fracture shall not reveal any defects in the structure.

### 2.2.3.4. Retesting for the burst test

Retesting is permitted for the burst test. A second burst test shall be performed on two containers which have been produced successively to the first container within the same batch.

If the results of these tests are satisfactory, the first test shall be ignored.

In the event where one or both of the retests fail to meet the requirements, the batch shall be rejected.

## 2.3. Hydraulic test

2.3.1. The containers representative of the type of container submitted for approval (without accessories but with the outlets closed off) shall withstand an inner hydraulic pressure of 3 000 kPa without leakages or becoming permanently distorted, according to the following requirements:

2.3.2. The water pressure in the container shall increase at an even rate until the test pressure of 3 000 kPa is reached.

2.3.3. The container shall remain under the test pressure long enough to make it possible to establish that the pressure is not falling off and that the container can be guaranteed leak proof.

2.3.4. After the test the container shall show no signs of permanent deformation.

2.3.5. Any container tested which does not pass the test shall be rejected.

### 2.3.6. Additional hydraulic tests to be performed on all-composite containers

#### 2.3.6.1. Ambient temperature pressure cycling test

##### 2.3.6.1.1. Test procedure

The finished container shall be pressure cycled to a maximum of 20 000 cycles, according to the following procedure:

(a) Fill the container to be tested with a non-corrosive fluid such as oil, inhibited water or glycol;

- (b) Cycle the pressure in the container between not more than 300 kPa and not less than 3 000 kPa at a rate not to exceed 10 cycles per minutes.

This cycle shall be performed at least 10 000 times and continued until 20 000 times unless a leak before break appears;

- (c) The number of cycles to failure shall be reported, along with the location and description of the failure initiation.

#### 2.3.6.1.2. Test interpretation

Before reaching 10 000 cycles, the container shall not fail or leak.

After completing 10 000 cycles, the container may leak before break.

#### 2.3.6.1.3. Retesting

Retesting is permitted for the ambient temperature pressure cycling test.

A second test shall be performed on two containers which have been produced successively to the first container within the same batch.

If the results of these tests are satisfactory, the first test shall be ignored.

In the event where one or both of the retests fail to meet the requirements, the batch shall be rejected.

#### 2.3.6.2. High temperature pressure cycling test

##### 2.3.6.2.1. Test procedure

Finished containers shall be cycle tested, without showing evidence of rupture, leakage, or fibre unravelling, as follows:

- (a) Fill the container to be tested with a non-corrosive fluid such as oil, inhibited water or glycol;
- (b) Condition for 48 hours at 0 kPa, 65 °C, and 95 per cent or greater relative humidity;
- (c) Hydrostatically pressurise for 3 600 cycles not exceeding 10 cycles per minute, between not more than 300 kPa and not less than 3 000 kPa at 65 °C and 95 per cent humidity.

Following the pressure cycling at high temperature, containers shall be submitted to the external leak test and then hydrostatically pressurised to failure in accordance with the burst test procedure.

##### 2.3.6.2.2. Test interpretation

The container shall comply with the external leak test requirements as defined in paragraph 2.3.6.3 below.

The container shall achieve a minimum burst pressure of 85 per cent of the burst pressure.

##### 2.3.6.2.3. Retesting

Retesting is permitted for the high temperature pressure cycling test.

A second test shall be performed on two containers which have been produced successively to the first container within the same batch.

If the results of these tests are satisfactory, the first test shall be ignored.

In the event where one or both of the retests fail to meet the requirements, the batch shall be rejected.

### 2.3.6.3. External leak test

#### 2.3.6.3.1. Test procedure

While under 3 000 kPa pressure, the container shall be submerged in soapy water to detect leakage (bubble test).

#### 2.3.6.3.2. Test interpretation

The container shall not show any leakage.

#### 2.3.6.3.3. Retesting

Retesting is permitted for the external leak test.

A second test shall be performed on two containers which have been produced successively to the first container within the same batch.

If the results of these tests are satisfactory, the first test shall be ignored. In the event where one or both of the retests fail to meet the requirements, the batch shall be rejected.

### 2.3.6.4. Permeation test

#### 2.3.6.4.1. Test procedure

All the tests shall be performed at 40 °C on a container fuelled with commercial propane at 80 per cent of its water capacity.

The test shall be held during at least 8 weeks until the steady state permeation of the structure is observed during at least 500 hours.

Then, the rate of the container weight loss shall be measured.

The graph of mass change per number of days shall be recorded.

#### 2.3.6.4.2. Test interpretation

The rate of mass loss shall be less than 0,15 g/hour.

#### 2.3.6.4.3. Retesting

Retesting is permitted for the permeation test.

A second test shall be performed on two containers which have been produced successively to the first container within the same batch.

If the results of these tests are satisfactory, the first test shall be ignored. In the event where one or both of the retests fail to meet the requirements, the batch shall be rejected.

### 2.3.6.5. LPG cycling test

#### 2.3.6.5.1. Test procedure

A container having successfully passed the permeation test shall be submitted to an ambient temperature pressure cycling test according to the requirements of paragraph 2.3.6.1 of this annex.

The container shall be sectioned and the liner/end boss interface shall be inspected.



## 2.3.6.5.2. Test interpretation

The container shall comply with the ambient temperature pressure cycling test requirements.

Inspection of the liner/end boss interface of the container shall not reveal any evidence of deterioration, such as fatigue cracking or electrostatic discharge.

## 2.3.6.5.3. Retesting

Retesting is permitted for the LPG cycling test.

A second test shall be performed on two containers which have been produced successively to the first container within the same batch.

If the results of these tests are satisfactory, the first test shall be ignored.

In the event where one or both of the retests fail to meet the requirements, the batch shall be rejected.

## 2.3.6.6. High temperature creep test

## 2.3.6.6.1. General

This test shall only be performed on all-composite containers with a resin matrix having a glass transition temperature ( $T_g$ ) below the design temperature + 50 °C.

## 2.3.6.6.2. Test procedure

One finished container shall be tested as follows:

- (a) The container shall be pressurised to 3 000 kPa and held at a temperature defined according to Table 3 on the basis of the test period duration:

Table 3

**Test temperature relating to the High temperature creep test duration**

T (°C)	Exposure time (h)
100	200
95	350
90	600
85	1 000
80	1 800
75	3 200
70	5 900
65	11 000
60	21 000

- (b) The container shall be submitted to an external leak test.

#### 2.3.6.6.3. Test interpretation

The maximum allowed volume increase is 5 per cent. The container shall meet the requirements of the external leak test as defined in paragraph 2.4.3 of this annex and the burst test as defined in paragraph 2.2 of this annex.

#### 2.3.6.6.4. Retesting

Retesting is permitted for the high temperature creep test.

A second test shall be performed on two containers which have been produced successively to the first container within the same batch.

If the results of these tests are satisfactory, the first test shall be ignored.

In the event where one or both of the retests fail to meet the requirements, the batch shall be rejected.

### 2.4. Non-destructive examination

#### 2.4.1. Radiographic examination

2.4.1.1. Welds shall be radiographed in compliance with ISO specification R 1106, using classification B.

2.4.1.2. When a wire-type indicator is used, the smallest diameter of the wire visible may not exceed the value of 0,10 mm.

When a stepped and holed type indicator is used, the diameter of the smallest hole visible may not exceed 0,25 mm.

2.4.1.3. Assessment of the weld radiographs shall be based on the original films in compliance with the practice recommended in standard ISO 2504, paragraph 6.

2.4.1.4. The following defects are not acceptable:

Cracks, inadequate welds or inadequate penetration of the weld.

2.4.1.4.1. For the container wall thickness  $\geq 4$  mm, the inclusions listed below are regarded as acceptable:

Any gas inclusion measuring not more than  $a/4$  mm;

Any gas inclusion measuring more than  $a/4$  mm but not more than  $a/3$  mm, which is more than 25 mm away from other gas inclusion measuring more than  $a/4$  mm and measuring not more than  $a/3$  mm;

Any elongated inclusion or any group of rounded inclusions in a row where the length represented (over a weld length of 12a) is not greater than 6 mm;

Gas inclusions over any 100 mm weld length, where the total area of all the figures is not greater than  $2a$  mm<sup>2</sup>.

2.4.1.4.2. For the container wall thickness  $< 4$  mm, the inclusions listed below are regarded as acceptable:

Any gas inclusion measuring not more than  $a/2$  mm;

Any gas inclusion measuring more than  $a/2$  mm but not more than  $a/1,5$  mm, which is more than 25 mm away from other gas inclusion measuring more than  $a/2$  mm and measuring not more than  $a/1,5$  mm;

Any elongated inclusion or any group of rounded inclusions in a row where the length represented (over a weld length of 12a) is not greater than 6 mm;

Gas inclusions over any 100 mm weld length, where the total area of all the figures is not greater than  $2a$  mm<sup>2</sup>.

#### 2.4.2. Macroscopic examination

The macroscopic examination of a full transverse section of the weld shall show a complete fusion on the surface treated with any acid from the macro-preparation and shall not show any assembly fault or a significant inclusion or other defects.

In case of doubt, a microscopic examination should be made of the suspect area.

#### 2.5. Examination on the outside of the weld for metal containers

##### 2.5.1. This examination is carried out when the weld has been completed.

The welded surface examined shall be well illuminated, and shall be free from grease, dust, scale residue or protective coating of any kind.

##### 2.5.2. The fusion of the welded metal with the parent metal shall be smooth and free from etching. There shall be no cracks, notching or porous patches in the welded surface and the surface adjacent to the wall. The welded surface shall be regular and even. Where a butt weld has been used, the excess thickness shall not exceed $1/4$ of the width of the weld.

#### 2.6. Bonfire test

##### 2.6.1. General

The bonfire test is designed to demonstrate that a container complete with the fire protection system, specified in the design, will prevent the burst of the container when tested under the specified fire conditions. The manufacturer shall describe the behaviour of the complete fire protection system including the designed drop to atmospheric pressure. The requirements of this test shall be deemed to be fulfilled for any container having the following characteristics in common with the parent container:

- (a) Same type approval owner,
- (b) Same shape (cylindrical, special shape),
- (c) Same material,
- (d) Same or greater wall thickness,
- (e) Same or smaller diameter (cylindrical container),
- (f) Same height or smaller height (special container shape),
- (g) Same or smaller external surface,
- (h) Same configuration of accessories fitted to the container <sup>(1)</sup>.

<sup>(1)</sup> Additional accessories, modifications and extensions of the accessories fitted to the container is possible without retesting, if notified to the Type Approval Authority which approved the container, considered to be unlikely to have an appreciable adverse effect. The Type Approval Authority may require a further test report from the Technical Service responsible. The container and its configurations of accessories will be indicated in Appendix 1 to Annex 2B.

#### 2.6.2. Container set-up

- (a) The container shall be placed in the designed position by the manufacturer with the container bottom approximately 100 mm above the fire source.
- (b) Shielding shall be used to prevent direct flame impingement on the fusible plug (PRD) if present. The shielding shall not be in direct contact with the fusible plug (PRD).
- (c) Any failure during the test of a valve, fitting or tubing that is not part of the intended protection system for the design shall invalidate the result.
- (d) Containers with a length of less than 1,65 m. The centre of the container shall be positioned over the centre of the fire source.
- (e) Containers with a length equal to or larger than 1,65 m. If the container is fitted with a pressure relief device at one side, the fire source shall commence at the opposite side of the container. If the container is fitted with pressure relief devices at both sides, or at more than one location along the length of the container, the centre of the fire source shall be centred midway between the pressure relief devices that are separated by the greatest horizontal distance.

#### 2.6.3. Fire source

A uniform fire source of 1,65 m length shall provide direct flame impingement on the container surface across its entire diameter.

Any fuel may be used for the fire source provided that it supplies uniform heat sufficient to maintain the specified test temperatures until the container is vented. The arrangement of the fire shall be recorded in sufficient detail to ensure that the rate of heat input to the container is reproducible. Any failure or inconsistency of the fire source during a test shall invalidate the result.

#### 2.6.4. Temperature and pressure measurements

During the bonfire test the following items shall be measured:

- (a) The fire temperature just below the container, along the bottom of the container, at minimum two locations, not more than 0,75 m apart;
- (b) The wall temperature in the bottom of the container;
- (c) The wall temperature within 25 mm from the pressure relief device;
- (d) The wall temperature on the top of the container, in the centre of the fire source;
- (e) The pressure inside the container.

Metallic shielding shall be used to prevent direct flame impingement on the thermocouples. Alternatively, thermocouples may be inserted into blocks of metal, measuring less than 25 mm<sup>2</sup>. During the test the thermocouple temperatures and the container pressure shall be recorded at intervals of 2 seconds or less.

#### 2.6.5. General test requirements

- (a) Container shall be filled with 80 per cent in volume of LPG (commercial fuel) and tested in the horizontal position at working pressure;
- (b) Immediately following the ignition, the fire shall produce flame impingement on the surface of the container, along 1,65 m length of the fire source across the container;

- (c) Within 5 minutes of ignition at least one thermocouple shall indicate the temperature of fire just below the container of at least 590 °C. This temperature shall be maintained for the remaining duration of the test, namely until when no overpressure is present in the container;
- (d) The severity of the test conditions shall not be mitigated by ambient conditions (e.g. rain, moderate/high wind etc.).

#### 2.6.6. Test results

- (a) A burst of the container shall invalidate the test result.
- (b) A pressure of more than 3 700 kPa, i.e. 136 per cent of the set pressure of the PRV (2 700 kPa), during the test shall invalidate the test result.  
  
A pressure between 3 000 and 3 700 kPa shall only invalidate the test result in case visible plastic deformation is observed.
- (c) In case the behaviour of the protection system does not comply with the specification of the manufacturer and it leads to a mitigating test condition the result shall be invalidated.
- (d) For a composite container a release of LPG via the surface is accepted in case of a controlled release. A release of gaseous LPG within 2 minutes after the start of the test or a release capacity of more than 30 litres per minute shall invalidate the test result.
- (e) The results shall be presented in a test summary and shall include the following data for each container as a minimum:
  - (i) Description of the container configuration.
  - (ii) Photo of the container set-up and PRD.
  - (iii) Applied method including time interval between measurements.
  - (iv) The elapsed time from ignition of the fire to the start of venting of LPG and actual pressure.
  - (v) Time to reach atmospheric pressure.
  - (vi) Pressure and temperature diagrams.

#### 2.7. Impact test

##### 2.7.1. General

At the choice of the manufacturer, all the impact tests may be carried out on one container or each may be carried out on a different container.

##### 2.7.2. Test procedure

For this test, the fluid medium shall be water/glycol mixture or another liquid having a low freezing point which does not change the properties of the container material.

A container filled with the fluid medium to the weight that equals the filling with 80 per cent of LPG with a reference mass of 0,568 kg/l, is projected, parallel to the length axle (x-axis in Figure 1) of the vehicle in which it is intended to be fitted at a velocity, V of 50 km/h, against a solid wedge, fixed horizontally, perpendicular to the movement of the container.

The wedge shall be installed so that the centre of gravity (c.g.) of the container hits the centre of the wedge.

The wedge shall have an angle  $\alpha$  of 90 degrees and the point of impact shall be rounded with a maximum radius of 2,5 mm.

The length of the wedge L, shall be at least equal to the width of the container in respect to its movement during the test. The height H of the wedge shall be at least 600 millimetres.

Figure 1

### Description of the impact test procedure

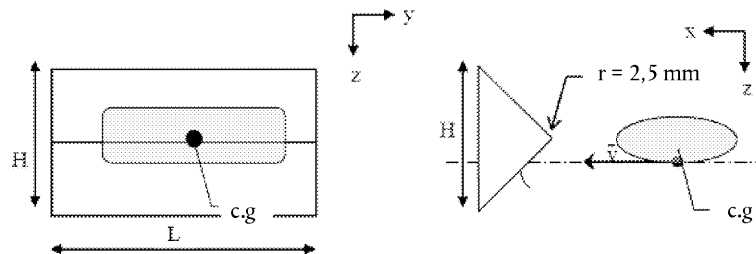

Note: c.g. = centre of gravity

In the case where a container can be installed in more than one position in the vehicle, each position shall be tested.

After this test, the container shall be submitted to an external leak test as defined in paragraph 2.3.6.3 of this annex.

#### 2.7.3. Test interpretation

The container shall comply with the external leak test requirements as defined in paragraph 2.3.6.3 of this annex.

#### 2.7.4. Retesting

Retesting is permitted for the impact test.

A second test shall be performed on two containers which have been produced successively to the first container within the same batch.

If the results of these tests are satisfactory, the first test shall be ignored.

In the event where one or both of the retests fail to meet the requirements, the batch shall be rejected.

#### 2.8. Drop test

##### 2.8.1. Test procedure

One finished container shall be drop tested at ambient temperature without internal pressurisation or attached valves. The surface onto which the containers are dropped shall be a smooth, horizontal concrete pad or flooring.

The drop height (Hd) shall be 2 m (measured to the lowest point of the container).

The same empty container shall be dropped:

- (a) In a horizontal position;
- (b) Vertically on each end;
- (c) At an angle of 45°.

Following the drop test, the containers shall be submitted to an ambient temperature pressure cycling test according the requirements of paragraph 2.3.6.1 of this annex.

#### 2.8.2. Test interpretation

The containers shall comply with the requirements of the ambient temperature pressure cycling test according the requirements of paragraph 2.3.6.1 of this annex.

#### 2.8.3. Retesting

Retesting is permitted for the drop test.

A second test shall be performed on two containers which have been produced successively to the first container within the same batch.

If the results of these tests are satisfactory, the first test shall be ignored.

In the event where one or both of the retests fail to meet the requirements, the batch shall be rejected.

#### 2.9. Boss torque test

##### 2.9.1. Test procedure

The body of the container shall be restrained against rotation and a torque of 2 times the valve or PRD installation torque specified by the manufacturer shall be applied to each end boss of the container, first in the direction to tighten a threaded connection, then in the untightening direction, and finally again in the tightening direction.

The container shall then be subjected to an external leak test in accordance with the requirements shown in paragraph 2.3.6.3 of this annex.

##### 2.9.2. Test interpretation

The container shall comply with the requirements of the external leak test as shown in paragraph 2.3.6.3 of this annex.

##### 2.9.3. Retesting

Retesting is permitted for the boss torque test.

A second test shall be performed on two containers which have been produced successively to the first container within the same batch.

If the results of these tests are satisfactory, the first test shall be ignored.

In the event where one or both of the retests fail to meet the requirements, the batch shall be rejected.

#### 2.10. Acid environment test

##### 2.10.1. Test procedure

A finished container shall be exposed for 100 hours to a 30 per cent sulphuric acid solution (battery acid with specific gravity of 1,219) while pressurised to 3 000 kPa. During the test, a minimum of 20 per cent of the total area of the container has to be covered by the sulphuric acid solution.

Then, the container shall be submitted to a burst test as defined in paragraph 2.2 of this annex.

2.10.2. Test interpretation

The burst pressure measured shall be at least 85 per cent of the container burst pressure.

2.10.3. Retesting

Retesting is permitted for the acid environment test.

A second test shall be performed on two containers which have been produced successively to the first container within the same batch.

If the results of these tests are satisfactory, the first test shall be ignored.

In the event where one or both of the retests fail to meet the requirements, the batch shall be rejected.

2.11. Ultra-violet (UV) test

2.11.1. Test procedure

When the container is directly subjected to sunlight (also behind glass), UV-radiation might degrade polymeric materials. Therefore, the manufacturer has to prove the ability of the outer layer material to withstand the UV-radiation during his lifetime of 20 years.

(a) If the outer layer has a mechanical (load carrying) function, the container shall be burst tested according to the requirements of paragraph 2.2 of this annex, after exposing to a representative UV-radiation;

(b) If the outer layer has a protective function, the manufacturer has to prove that the coating remains integer within 20 years, in order to protect the under-laying structural layers from a representative UV-radiation.

2.11.2. Test interpretation

When the outer layer has a mechanical function, the container shall comply with the burst test requirements as defined in paragraph 2.2 of this annex.

2.11.3. Retesting

Retesting is permitted for the ultra-violet test.

A second test shall be performed on two containers which have been produced successively to the first container within the same batch.

If the results of these tests are satisfactory, the first test shall be ignored.

In the event where one or both of the retests fail to meet the requirements, the batch shall be rejected.

---



Appendix 1

Figure 1

Types of main longitudinal butt welds

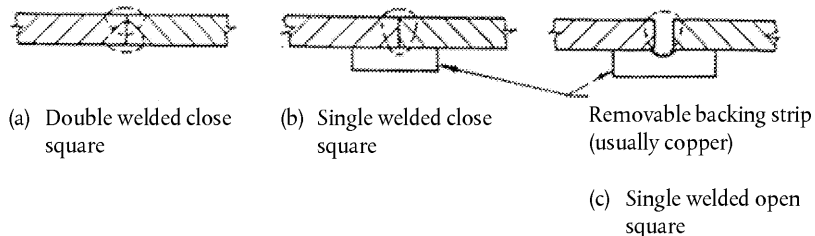
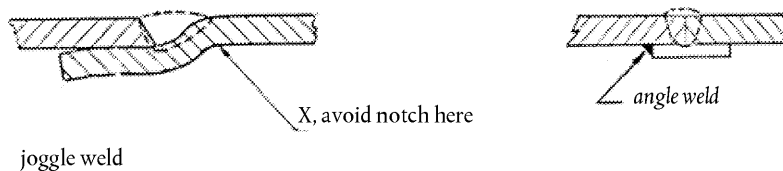

Figure 2

Circumferential butt weld



weld on backing strip

Note: The angle weld can be performed as a "chain-weld"

Figure 3

Examples of welded studed plates

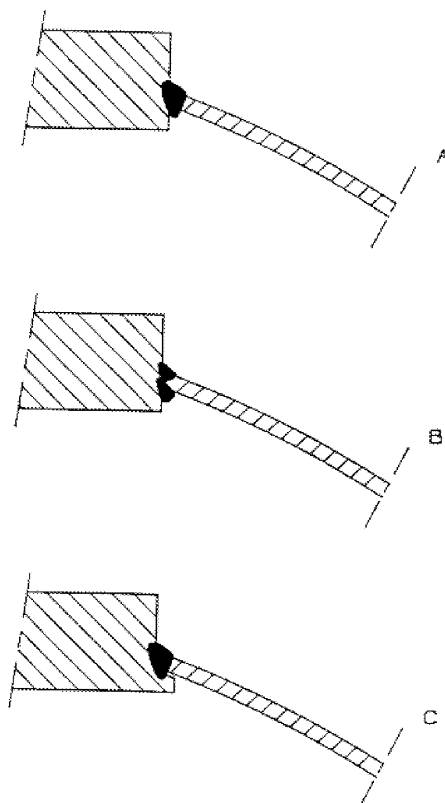
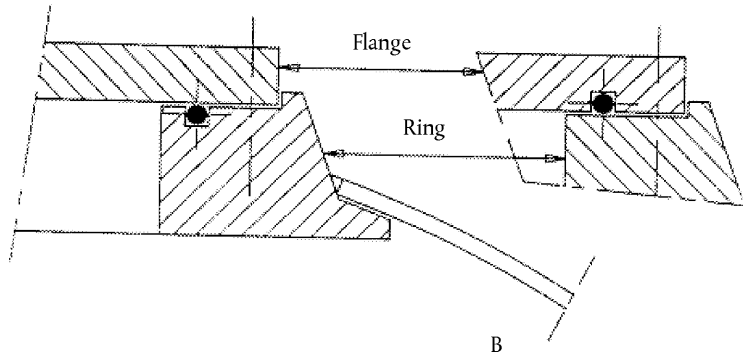
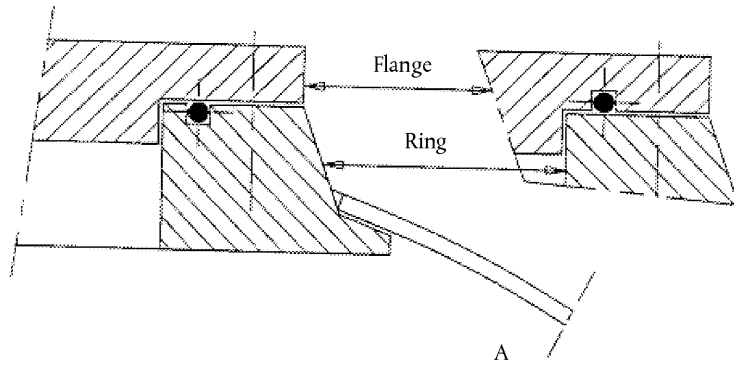

Figure 4

**Examples of welded rings with flange**



—

## Appendix 2

Figure 1

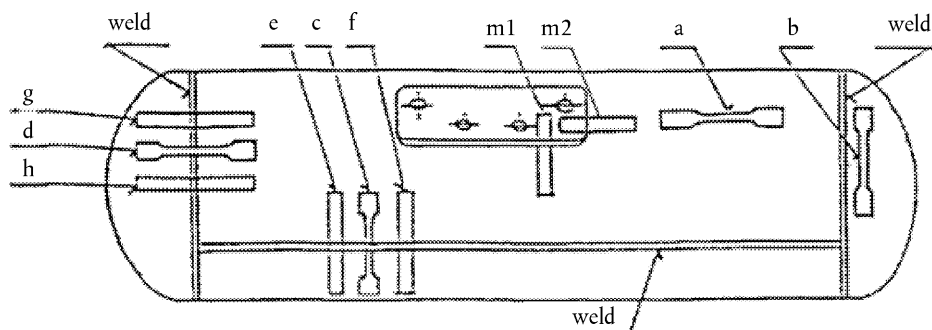
**Containers with longitudinal and circumferential welds, location of test-pieces**

- (a) Tensile test on parent material
- (b) Tensile test on parent material of the bottom
- (c) Tensile test on a longitudinal weld
- (d) Tensile test on a circumferential weld
- (e) Bend test on a longitudinal weld, the inner surface in tension
- (f) Bend test on a longitudinal weld, the outer surface in tension
- (g) Bend test on a circumferential weld, the inner surface in tension
- (h) Bend test on a circumferential weld, the outer surface in tension
- (m1, m2) Macro sections through valve boss/plate welds (side-mounted valve block)

Figure 2a

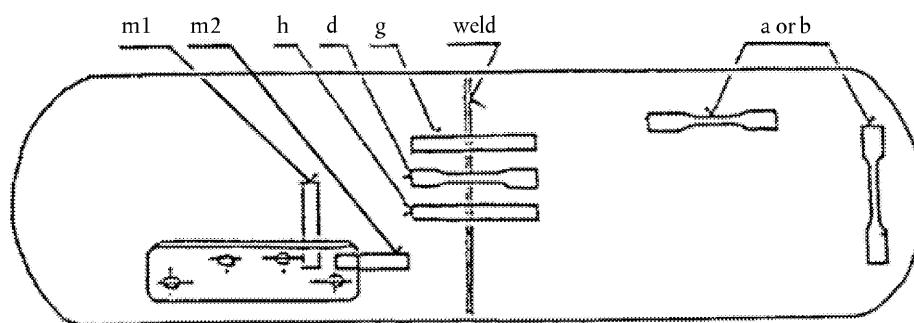
**Containers with circumferential welds only and side-mounted valve blocks; location of test-pieces**

- (a) or (b) Tensile test on parent material
- (d) Tensile test on a circumferential weld
- (g) Bend test on a circumferential weld, the inner surface in tension
- (h) Bend test on a circumferential weld, the outer surface in tension
- (m1, m2) Macro sections through valve boss/plate welds (side-mounted valve block)

Figure 2b

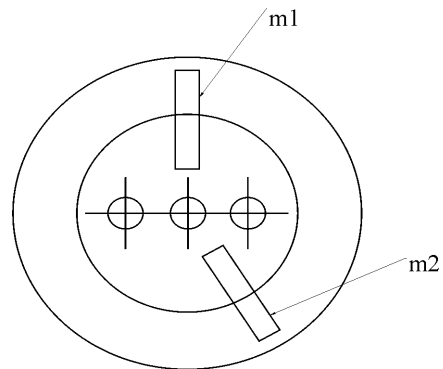
**Containers with circumferential welds only and valve boss/plate fitted to the end**

(m1, m2) Macro sections through valve boss/plate welds

(Refer to Figure 2a for other locations of test-pieces)

—

## Appendix 3

Figure 1

**Illustration of bend test**

Figure 2

**Test piece for tensile test perpendicular to the weld**

## Appendix 4

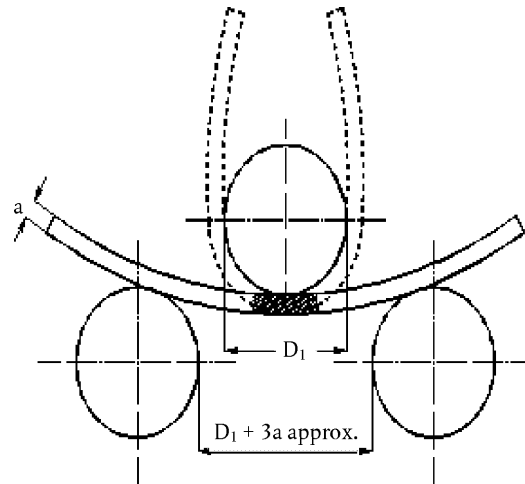
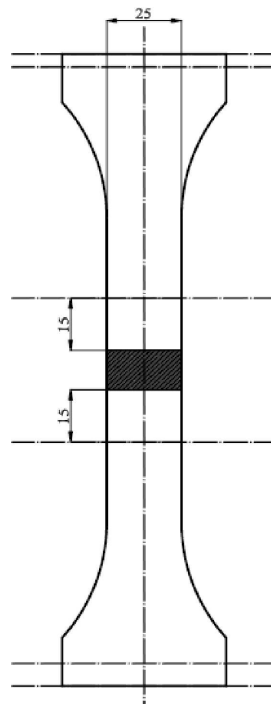
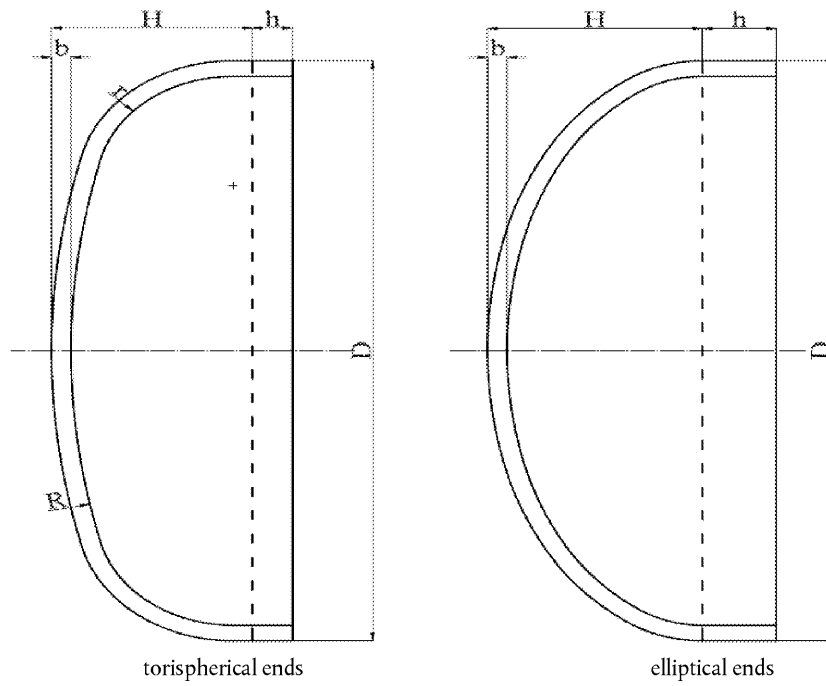

Note: For torispherical ends

$$H = (R + b) - \sqrt{\left[ \left[ (R + b) - \frac{D}{2} \right] \left[ (R + b) + \frac{D}{2} - 2(r + b) \right] \right]}$$

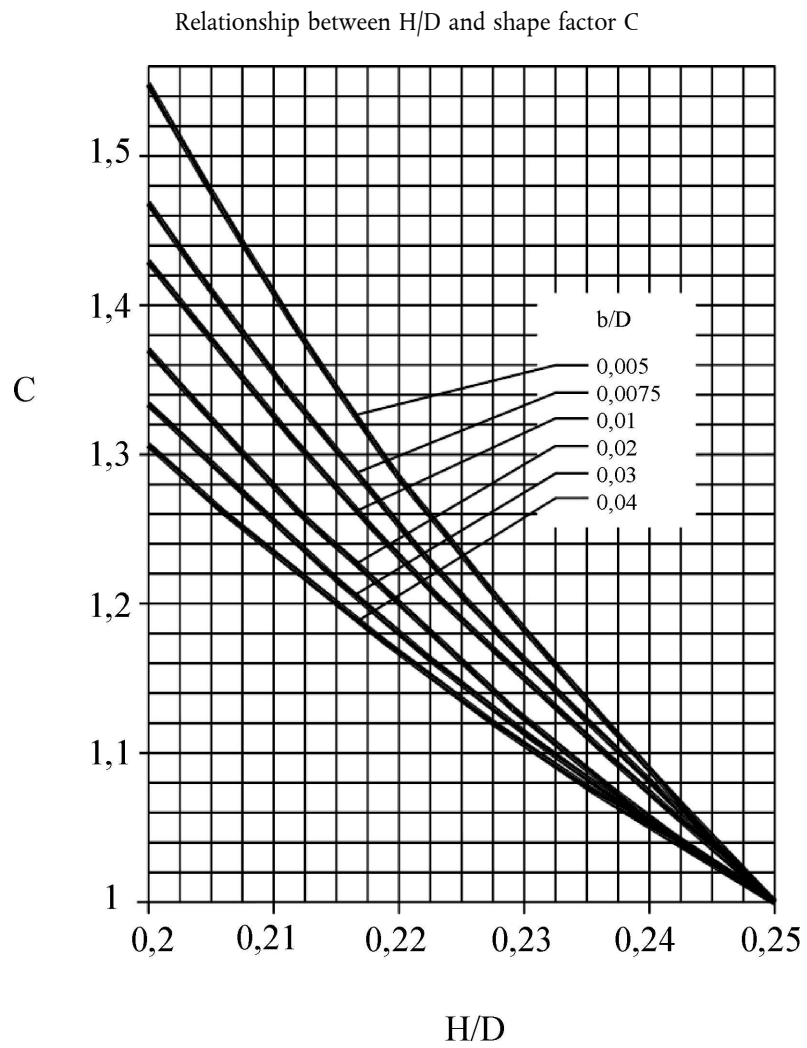

Values of shape factor C for H/D between 0,20 and 0,25

Relationship between H/D and shape factor C

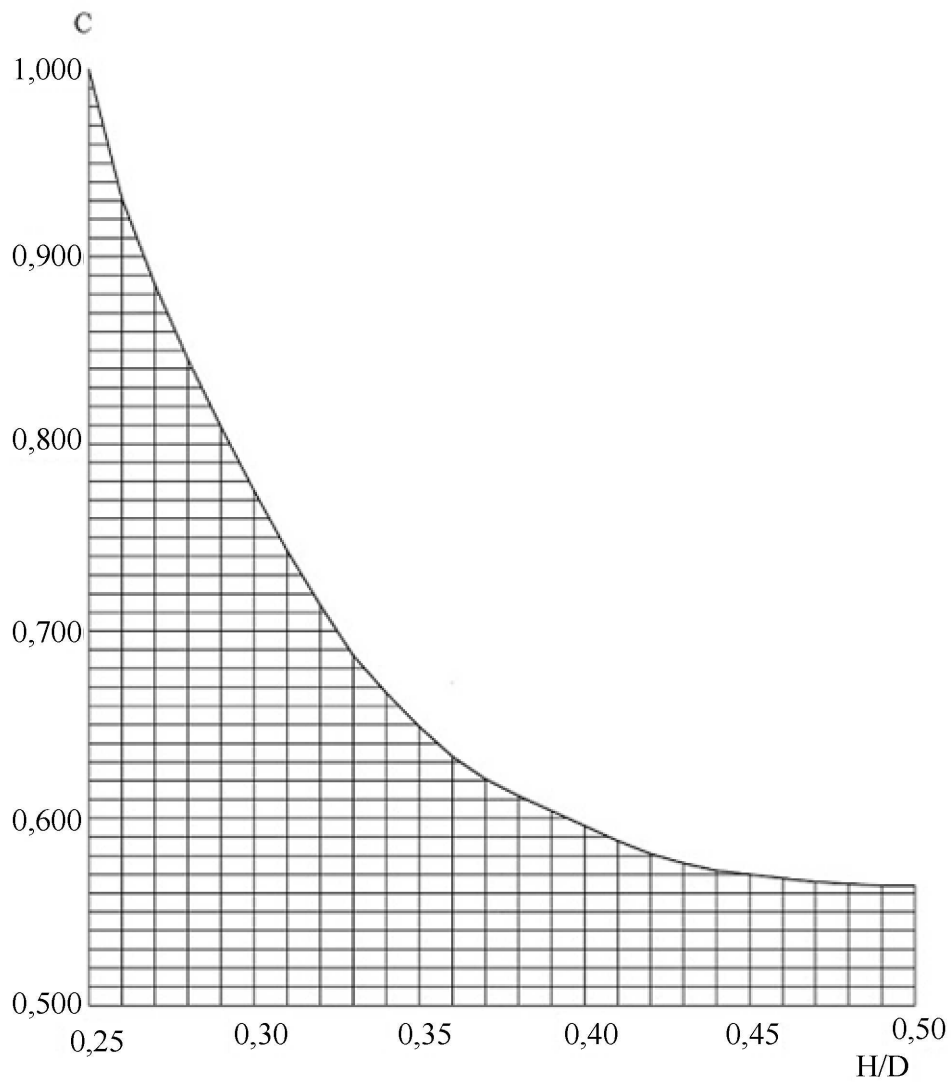

Values of shape factor C for H/D between 0,25 and 0,50

H/D	C
0,25	1,000
0,26	0,931
0,27	0,885
0,28	0,845
0,29	0,809
0,30	0,775
0,31	0,743
0,32	0,714
0,33	0,687
0,34	0,667

H/D	C
0,38	0,612
0,39	0,604
0,40	0,596
0,41	0,588
0,42	0,581
0,43	0,576
0,44	0,572
0,45	0,570
0,46	0,568
0,47	0,566



H/D	C
0,35	0,649
0,36	0,633
0,37	0,621

H/D	C
0,48	0,565
0,49	0,564
0,50	0,564

Note: Intermediate values may be obtained by linear interpolation

---

Appendix 5

EXAMPLES OF SPECIAL VESSELS

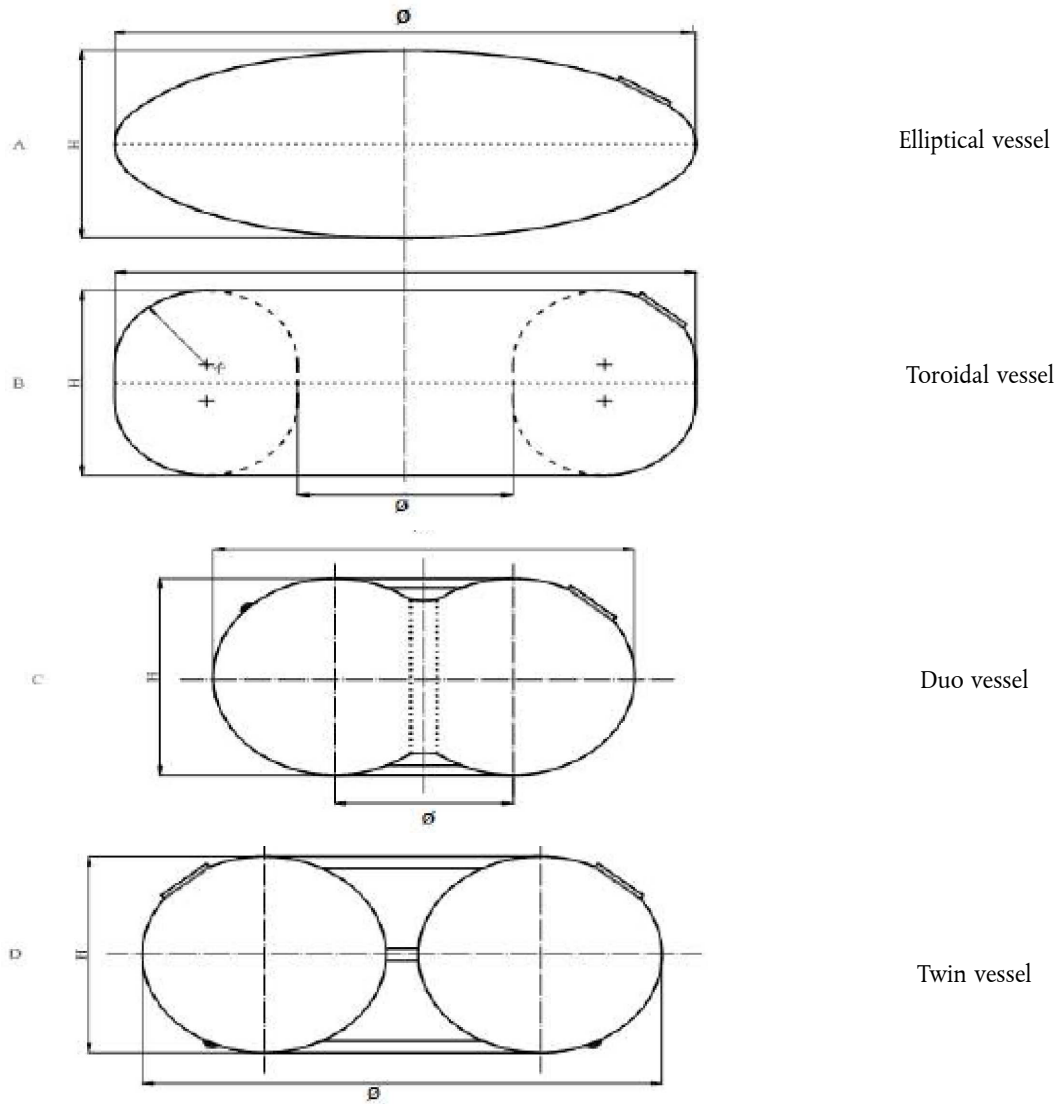

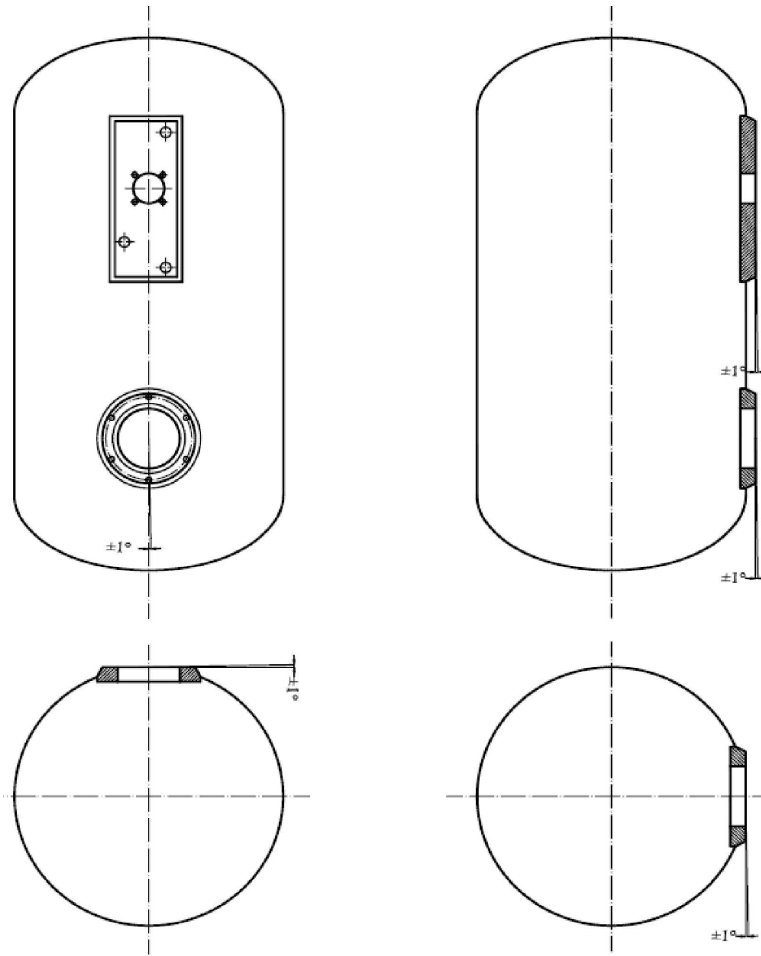

—

## Appendix 6

**MATERIAL TEST METHODS**

## 1. Chemical resistance

Materials used in an all-composite container shall be tested according to standard ISO 175 for 72 hours at room temperature.

Demonstrating the chemical resistance by using data from literature is also allowed.

Compatibility with the following media shall be checked:

- (a) Brake fluid;
- (b) Window cleaner;
- (c) Cooling liquid;
- (d) Non-leaded petrol;
- (e) Solution of deionised water, sodium chloride (2,5 per cent by mass  $\pm$  0,1 per cent), (calcium chloride (2,5 per cent by mass  $\pm$  0,1 per cent) and sulphuric acid sufficient to achieve a solution of pH  $4,0 \pm 0,2$ .

Test acceptance criteria:

- (a) Elongation:

The elongation of a thermoplastic material, after testing, shall be at least 85 per cent of the initial elongation. The elongation of an elastomer, after testing, shall be at least larger than 100 per cent.

- (b) For structural components (e.g. fibres):

The residual strength for a structural component after testing shall be at least 80 per cent of the original tensile strength.

- (c) Non-structural components (e.g. coating):

There are no visual cracks allowed.

## 2. Composite structure

- (a) Fibres embedded in a matrix

Tensile properties:	ASTM 3039	Fibre-resin composites
	ASTM D2343	Glass, Aramid (tens. prop. yarns glass)
	ASTM D4018.81	Carbon (tens.prop.continuous filament) with special remark for the matrix
Shear properties:	ASTM D2344	(Interlaminar shearstrength of parallel fibre composite by short beam method)

- (b) Dry fibres on an isotensoid shape

Tensile properties: ASTM D4018.81 Carbon (continuous filament), other fibres.

### 3. Protective coating

UV-radiation degrades polymeric material when directly subjected to the sunlight. Depending on the installation, the manufacturer has to proof a 'safe life' for the coating.

### 4. Thermoplastic components

The Vicat softening temperature of a thermoplastic component shall be above 70 °C. For structural components, the Vicat softening temperature shall be at least 75 °C.

### 5. Thermoset components

The Vicat softening temperature of a thermo-set component shall be above 70 °C.

### 6. Elastomeric components

The glass transition temperature ( $T_g$ ) of an elastomer component shall be lower than  $-40$  °C. The glass transition temperature shall be tested according ISO 6721 'Plastics — Determination of dynamic mechanical properties'. The  $T_g$ -onset is derived from the plotted diagram storage modulus versus temperature by determining the temperature, where the two tangents, which are representing the slopes of the diagram before and after the dramatic loss of stiffness, intersects.

---

## ANNEX 11

**PROVISIONS REGARDING THE APPROVAL OF GAS INJECTION DEVICES, OR GAS MIXING PIECES, OR INJECTORS AND THE FUEL RAIL**

1. Gas injection device or injector
  - 1.1. Definition: See paragraph 2.10 of this Regulation.
  - 1.2. Component classification (according to Figure 1, para. 2): Class 1 or Class 0.
  - 1.3. Classification pressure:  
Class 0: WP declared  
Class 1: 3 000 kPa.
  - 1.4. Design temperatures:  
– 20 °C to 120 °C  
  
For temperatures exceeding the abovementioned values, special tests conditions are applicable.
  - 1.5. General design rules:  
Paragraph 6.15.2, Provisions regarding the electrical insulation.  
Paragraph 6.15.2.1, Provisions regarding the insulation class.  
Paragraph 6.15.3.1, Provisions when the power is switched off.  
Paragraph 6.15.4.1, Heat exchange medium (compatibility and pressure requirements).
  - 1.6. Applicable test procedures:

Overpressure test	Annex 15, para. 4
External leakage	Annex 15, para. 5
High temperature	Annex 15, para. 6
Low temperature	Annex 15, para. 7
LPG compatibility	Annex 15, para. 11 (**)
Corrosion resistance	Annex 15, para. 12 (*)
Resistance to dry heat	Annex 15, para. 13 (**)
Ozone ageing	Annex 15, para. 14 (**)
Creep	Annex 15, para. 15 (**)
Temperature cycle	Annex 15, para. 16 (**)
2. Gas injection device or gas mixing piece
  - 2.1. Definition: See paragraph 2.10 of this Regulation.
  - 2.2. Component classification (according to Figure 1, para. 2):  
Class 2: for the part with a maximum regulated pressure during operation of 450 kPa.  
Class 2A: for the part with a maximum regulated pressure during operation of 120 kPa.

2.3. Classification pressure:

Parts of Class 2: 450 kPa.

Parts of Class 2A: 120 kPa.

2.4. Design temperatures:

– 20 °C to 120 °C, when the fuel pump is mounted outside the container.

For temperatures exceeding the abovementioned values, special tests conditions are applicable.

2.5. General design rules:

Paragraph 6.15.2, Provisions regarding the electrical insulation.

Paragraph 6.15.2.1, Provisions regarding the insulation class.

Paragraph 6.15.3.1, Provisions when the power is switched off.

Paragraph 6.15.4.1, Heat exchange medium (compatibility and pressure requirements).

2.6. Applicable test procedures:

Overpressure test Annex 15, para. 4

External leakage Annex 15, para. 5

High temperature Annex 15, para. 6

Low temperature Annex 15, para. 7

LPG compatibility Annex 15, para. 11 (\*\*)

Corrosion resistance Annex 15, para. 12 (\*)

3. Fuel rail

3.1. Definition: See paragraph 2.18 of this Regulation.

3.2. Component classification (according to Figure 1, para. 2):

Fuel rails can be of Class 0, 1, 2 or 2A.

3.3. Classification pressure:

Parts of Class 0: WP declared

Parts of Class 1: 3 000 kPa.

Parts of Class 2: 450 kPa.

Parts of Class 2A: 120 kPa.

3.4. Design temperatures:

– 20 °C to 120 °C

For temperatures exceeding the abovementioned values, special tests conditions are applicable.

3.5. General design rules: (not used)

3.6. Applicable test procedures:

3.6.1. For fuel rails of Class 0 and 1:

Overpressure test	Annex 15, para. 4
External leakage	Annex 15, para. 5
High temperature	Annex 15, para. 6
Low temperature	Annex 15, para. 7
LPG compatibility	Annex 15, para. 11 (**)
Corrosion resistance	Annex 15, para. 12 (*)
Resistance to dry heat	Annex 15, para. 13 (**)
Ozone ageing	Annex 15, para. 14 (**)
Creep	Annex 15, para. 15 (**)
Temperature cycle	Annex 15, para. 16 (**)

3.6.2. For fuel rails of Class 2 and/or 2A:

Overpressure test	Annex 15, para. 4
External leakage	Annex 15, para. 5
High temperature	Annex 15, para. 6
Low temperature	Annex 15, para. 7
LPG compatibility	Annex 15, para. 11 (**)
Corrosion resistance	Annex 15, para. 12 (*)

---

(\*) Only for metallic parts.

(\*\*) Only for non-metallic parts.



## ANNEX 12

**PROVISIONS REGARDING THE APPROVAL OF THE GAS DOSAGE UNIT WHEN NOT COMBINED WITH THE GAS INJECTION DEVICE(S)**

1. Definition: See paragraph 2.11 of this Regulation.
2. Component classification (according to Figure 1, para. 2):  
Class 2: for the part with a maximum regulated pressure during operation of 450 kPa.  
Class 2A: for the part with a maximum regulated pressure during operation of 120 kPa.
3. Classification pressure:  
Parts of Class 2: 450 kPa.  
Parts of Class 2A: 120 kPa.
4. Design temperatures:  
– 20 °C to 120 °C  
For temperatures exceeding the abovementioned values, special tests conditions are applicable.
5. General design rules:  
Paragraph 6.15.2, Provisions regarding the electrical insulation.  
Paragraph 6.15.3.1, Provisions on valves activated by electrical power.  
Paragraph 6.15.4, Heat exchange medium (compatibility and pressure requirements).  
Paragraph 6.15.5, Overpressure bypass security.
6. Applicable test procedures:

Overpressure test	Annex 15, para. 4
External leakage	Annex 15, para. 5
High temperature	Annex 15, para. 6
Low temperature	Annex 15, para. 7
LPG compatibility	Annex 15, para. 11 (**)
Corrosion resistance	Annex 15, para. 12 (*)

Remarks:

The parts of the gas dosage unit (Class 2 or 2A) shall be leak proof with the outlet(s) of that part closed.

For the overpressure test all the outlets including those of the coolant compartment shall be closed off.

---

(\*) Only for metallic parts.

(\*\*) Only for non-metallic parts.

## ANNEX 13

**PROVISIONS REGARDING THE APPROVAL OF THE PRESSURE AND/OR TEMPERATURE SENSOR**

## 1. Definition:

Pressure sensor: See paragraph 2.13 of this Regulation.

Temperature sensor: See paragraph 2.13 of this Regulation.

## 2. Component classification (according to Figure 1, para. 2):

Pressure and temperature sensors can be of Class 0, 1, 2 or 2A.

## 3. Classification pressure:

Parts of Class 0: WP declared

Parts of Class 1: 3 000 kPa.

Parts of Class 2: 450 kPa.

Parts of Class 2A: 120 kPa.

## 4. Design temperatures:

– 20 °C to 120 °C

For temperatures exceeding the abovementioned values, special tests conditions are applicable.

## 5. General design rules:

Paragraph 6.15.2, Provisions regarding the electrical insulation.

Paragraph 6.15.4.1, Heat exchange medium (compatibility and pressure requirements).

Paragraph 6.15.6.2, Gas flow prevention.

## 6. Applicable test procedures:

## 6.1. For parts of Class 0 and 1:

Overpressure test	Annex 15, para. 4
External leakage	Annex 15, para. 5
High temperature	Annex 15, para. 6
Low temperature	Annex 15, para. 7
LPG compatibility	Annex 15, para. 11 (**)
Corrosion resistance	Annex 15, para. 12 (*)
Resistance to dry heat	Annex 15, para. 13 (**)
Ozone ageing	Annex 15, para. 14 (**)
Creep	Annex 15, para. 15 (**)
Temperature cycle	Annex 15, para. 16 (**)

## 6.2. For parts of Class 2 or 2A:

Overpressure test Annex 15, para. 4

External leakage Annex 15, para. 5

---

High temperature	Annex 15, para. 6
Low temperature	Annex 15, para. 7
LPG compatibility	Annex 15, para. 11 (**)
Corrosion resistance	Annex 15, para. 12 (*)

(\*) Only for metallic parts.

(\*\*) Only for non-metallic parts.

---

## ANNEX 14

**PROVISIONS REGARDING THE APPROVAL OF THE ELECTRONIC CONTROL UNIT**

1. The electronic control unit can be any device which controls the LPG demand of the engine and establishes the cut-off of the remotely-controlled service valve(s), cut-off valves and fuel pump of the LPG system in case of a broken fuel supply pipe or/and in case of stalling of the engine.
  2. The switching off delay of the service cut-off valves after stalling of the engine may not be more than 5 seconds.
  - 2.1. Notwithstanding the provisions of paragraphs 1 and 2 above, the remotely controlled service valve(s) and shut-off valves may stay in an open position during the commanded stop phases.
  3. The electronic control unit shall comply with relevant electromagnetic compatibility (EMC) requirements according to Regulation No 10, 02 series of amendments or equivalent.
  4. Electrical failure of the vehicle system may not lead to uncontrolled opening of any valve.
  5. The output of the electronic control unit shall be inactive when the electric power is switched off or removed.
-

## ANNEX 15

## TEST PROCEDURES

1. Classification
  - 1.1. LPG components for use in vehicles shall be classified with regard to the maximum operating pressure and function, according to Chapter 2 of this Regulation.
  - 1.2. The classification of the components determines the tests which have to be performed for type approval of the components or parts of the components.
2. Applicable test procedures

In Table 1 the applicable test procedures dependent on the classification are shown.

Table 1

Test	Class 0	Class 1	Class 2(A)	Class 3	Paragraph
Overpressure	x	x	x	x	4
External leakage	x	x	x	x	5
High temperature	x	x	x	x	6
Low temperature	x	x	x	x	7
Seat leakage	x	x		x	8
Endurance/Functional tests	x	x		x	9
Operational test	x			x	10
LPG compatibility	x	x	x	x	11
Corrosion resistance	x	x	x	x	12
Resistance to dry heat	x	x		x	13
Ozone ageing	x	x		x	14
Creep	x	x		x	15
Temperature cycle	x	x		x	16
Compatibility with heat exchange fluid	x		x		17

3. General requirements
  - 3.1. Leakage tests shall have to be conducted with pressurised gas like air or nitrogen.
  - 3.2. Water or another fluid may be used to obtain the required pressure for the hydrostatic strength test.
  - 3.3. All test values shall indicate the type of test medium used, if applicable.

- 3.4. The test period for leakage and hydrostatic strength tests shall be not less than 1 minute.
- 3.5. All tests shall be performed at a room temperature of  $20\text{ °C} \pm 5\text{ °C}$ , unless otherwise stated.
4. Overpressure test under hydraulic conditions

A LPG containing component shall withstand without any visible evidence of rupture or permanent distortion a hydraulic test pressure which is determined by Table 1 (of 2,25 times the maximum classification pressure) during minimal 1 minute with the outlet of the high pressure part plugged.

The samples, previously subjected to the durability test of paragraph 9 of this annex are to be connected to a source of hydrostatic pressure. A positive shut-off valve and a pressure gauge, having a pressure range of not less than 1,5 times nor more than 2 times the test pressure, are to be installed in the hydrostatic pressure supply piping.

Table 2 shows the classification pressure and the pressures to be used in the overpressure test according to the classification:

Table 2

Classification of component	Classification pressure [kPa]	Hydraulic test pressure for over-pressure test [kPa]
Class 0	WP	2,25 WP
Class 1	3 000	6 750
Class 3	3 000 or WP	6 750 or 2,25 WP
Class 2A	120	270
Class 2	450	1 015

5. External leakage test
- 5.1. A component shall be free from leakage through stem or body seals or other joints, and shall not show evidence of porosity in casting when tested as described in paragraph 5.3 below at any aerostatic pressure between 0 and the pressure shown in Table 3. The above prescriptions are deemed to be satisfied, if the provisions of paragraph 5.4 below are met.
- 5.2. The test shall be performed at the following conditions:
- (a) At room temperature;
  - (b) At the minimum operating temperature;
  - (c) At the maximum operating temperature.
- The maximum and minimum operating temperatures are given in the annexes.
- 5.3. During this test the equipment under test (EUT) will be connected to a source of aerostatic pressure (of 1,5 times the maximum pressure and in the case of a Class 3 component, 2,25 times the maximum classification pressure). A positive shut-off valve and a pressure gauge having a pressure range of not less than 1,5 times nor more than 2 times the test pressures are to be installed in the pressure supply piping. The pressure gauge is to be installed between the positive shut-off valve and the sample under test. While under the applied test pressure, the sample should be submerged in water to detect leakage or any other equivalent test method (flow measurement or pressure drop).

Table 3

**The classification and leakage test pressures according to the classification**

Classification of component	Classification pressure [kPa]	Test pressure for leakage test [kPa]
Class 0	WP	1,5 WP
Class 1	3 000	4 500
Class 2A	120	180
Class 2	450	675
Class 3	3 000	6 750

5.4. The external leakage shall be lower than the requirements stated in the annexes or, if no requirements are mentioned, the external leakage shall be lower than 15 cm<sup>3</sup>/hour with the outlet plugged, when submitted to a gas pressure equal to the leakage test pressure.

6. High temperature test

A LPG containing component shall not leak more than 15 cm<sup>3</sup>/hour with the outlet plugged when submitted to a gas pressure at maximum operating temperature, as indicated in the annexes, equal to the leakage test pressure (Table 3, paragraph 5.3 above). The component shall be conditioned for at least 8 hours at this temperature.

7. Low temperature test

A LPG containing component shall not leak more than 15 cm<sup>3</sup>/hour with the outlet plugged when submitted to a gas pressure, at the minimum operating temperature (– 20 °C), equal to the leakage test pressure (Table 3, paragraph 5.3 above). The component shall be conditioned for at least 8 hours at this temperature.

8. Seat leakage test

8.1. The following tests for seat leakage are to be conducted on samples of service valve or filling unit which have previously been subjected to the external leak test of paragraph 5 above.

8.1.1. Seat leakage tests are conducted with the inlet of the sample valve connected to a source of aerostatic pressure, the valve in the closed position, and with the outlet open. A positive shut-off valve and a pressure gauge having a pressure range of not less than 1,5 times nor more than 2 times the test pressures are to be installed in the pressure supply piping. The pressure gauge is to be installed between the positive shut-off valve and the sample under test. While under the applied test pressure, observations for leakage are to be made with the open outlet submerged in water unless otherwise indicated.

8.1.2. Conformance with paragraphs 8.2 to 8.8 below is to be determined by connecting a length of tubing to the valve outlet. The open end of this outlet tube is to be located within an inverted graduated cylinder which is calibrated in cubic centimetres. The inverted cylinder is to be closed by a water seal. The apparatus is to be adjusted so that:

(a) the end of the outlet tube is located approximately 13 mm above the water level within the inverted graduated cylinder; and

(b) the water within and exterior to the graduated cylinder is at the same level. With these adjustments made, the water level within the graduated cylinder is to be recorded. With the valve in the closed position assumed as the result of normal operation, air or nitrogen at the specified test pressure is to be applied to the valve inlet for a test period of not less than 2 minutes. During this time, the vertical position of the graduated cylinder is to be adjusted, if necessary, to maintain the same water level within and exterior to it.

At the end of the test period and with the water within and exterior to the graduated cylinder at the same level, the level of water within the graduated cylinder is again recorded. From the change of volume within the graduated cylinder, the leakage rate is to be calculated according to the following formula:

$$V_1 = V_t \times \frac{60}{t} \times \left( \frac{273}{T} \times \frac{P}{101,6} \right)$$

Where:

$V_1$  = leakage rate, cubic centimetres of air or nitrogen per hour.

$V_t$  = increase in volume within graduated cylinder during test.

$t$  = time of test, minutes.

$P$  = barometric pressure during test, in kPa.

$T$  = ambient temperature during test, in K.

- 8.1.3. Instead of the method described above, leakage may be measured by a flowmeter installed on the inlet side of the valve under test. The flowmeter shall be capable of indicating accurately, for the test fluid employed, the maximum leakage flow rates permitted.
- 8.2. The seat of a shut-off valve, when in the closed position, shall be free from leakage at any aerostatic pressure between 0 to 3 000 kPa or from 0 to WP in accordance with the classification pressure of the valve.
- 8.3. A non-return valve provided with a resilient seat, when in the closed position, shall not leak when subjected to any aerostatic pressure between 50 and 3 000 kPa.
- 8.4. A non-return valve provided with a metal-to-metal seat, when in the closed position, shall not leak at a rate exceeding 0,50 dm<sup>3</sup>/hour when subjected to an inlet pressure up to the test pressure according to Table 3 in paragraph 5.3 above
- 8.5. The seat of the upper non-return valve used in the assembly of a filling unit, when in the closed position, shall be free from leakage at any aerostatic pressure between 50 and 3 000 kPa.
- 8.6. The seat of a service coupling, when in the closed position, shall be free from leakage at any aerostatic pressure between 0 to 3 000 kPa.
- 8.7. The gas-tube pressure relief valve shall not have internal leakage up to 3 000 kPa or up to WP, in accordance with the classification pressure of the valve.
- 8.8. The pressure relief valve (discharge valve) shall not have internal leakage up to 2 600 kPa.
9. Endurance test
- 9.1. A filling unit or service valve shall be capable of conforming to the applicable leakage test requirements of paragraphs 5 and 8 above, after being subjected to a number of cycles of opening and closing as mentioned in the annexes to this Regulation.
- 9.2. A shut-off valve is to be tested with the valve outlet plugged. The valve body filled with n-hexane, and the valve inlet subjected to a pressure of 3 000 kPa or of WP in accordance with the classification pressure of the valve.
- 9.3. An endurance test is to be conducted at a rate not faster than 10 times per minute. For a shut-off valve, the closing torque is to be consistent with the size of handwheel, wrench, or other means employed to operate the valve.
- 9.4. The appropriate tests for external and seat leakage, as described under external leakage test under paragraph 5 above and seat leakage test under paragraph 8 are to be conducted immediately following the endurance test.



9.5. Endurance for 80 per cent stop valve

9.5.1. The 80 per cent stop valve shall be capable to withstand 6 000 complete filling cycles to the maximum filling degree.

9.6. Endurance test for pressure regulator and vaporiser

The regulator shall be able to withstand 50 000 cycles without any failure when tested according to the following procedure:

- (a) Recycle the regulator for 95 per cent of the total number of cycles at room temperature and at the classification pressure. Each cycle shall consist of flow until stable outlet pressure has been obtained, after which the gas flow shall be shut off by a downstream valve within 1 s, until the downstream lock-up pressure has stabilised. Stabilised outlet pressures are defined as set pressure  $\pm$  15 per cent for at least 5 s.
- (b) Cycle the inlet pressure of the regulator for 1 per cent of the total number of cycles at room temperature from 100 per cent to 50 per cent of the classification pressure. The duration of each cycle shall be no less than 10 s.
- (c) Repeat the cycling procedure listed in subparagraph (a) at 120 °C at the classification pressure for 1 per cent of the total number of cycles.
- (d) Repeat the cycling procedure listed in subparagraph (b) at 120 °C at the classification pressure for 1 per cent of the total number of cycles.
- (e) Repeat the cycling procedure listed in subparagraph (a) at – 20 °C and 50 per cent of classification pressure for 1 per cent of the total number of cycles.
- (f) Repeat the cycling procedure listed in subparagraph (b) at – 20 °C and 50 per cent of classification pressure for 1 per cent of the total number of cycles.
- (g) At the completion of all tests indicated in subparagraphs (a), (b), (c), (d), (e) and (f), the regulator shall be leak proof as described under external leakage test under paragraph 5 above, at the temperatures of – 20 °C, at the room temperature and at the temperature of + 120 °C.

10. Operational tests

10.1. Operation test of the (gas-tube) pressure relief valve

10.1.1. In the case of pressure relief valves, three samples of each size, design, and setting are to be used for start-to-discharge and resealing pressure tests. This same set of three valves is to be used for flow capacity tests for other observations indicated in the following paragraphs.

Not less than two successive start-to-discharge and resealing pressure observations are to be made on each of the three test valves under test No 1 and 3 of paragraphs 10.1.2 and 10.1.4 below.

10.1.2. Start-to-discharge and resealing pressures of pressure relief valves — test No 1

10.1.2.1. Before being subjected to a flow capacity test, the start-to-discharge pressure of each of three samples of a pressure relief valve of a specific size, design, and setting shall be within + 3 per cent of the average of the pressures, but the start-to-discharge pressure of any one of the three valves shall be not less than 95 per cent, not more than 105 per cent, of the set pressure marked on the valve.

10.1.2.2. The resealing pressure of a pressure relief valve before being subjected to a flow capacity test shall be not less than 50 per cent of the initially observed start-to-discharge pressure.

10.1.2.3. A pressure relief is to be connected to an air or other aerostatic supply source capable of being maintained at a pressure of at least 500 kPa effective pressure above the marked set pressure of the valve being tested. A positive shut-off valve and a pressure gauge having a pressure range of not less than 1,5 times nor more than 2 times the test pressure are to be installed in the pressure supply piping. The pressure gauge is to be installed in the piping between the valve being tested and the positive shut-off valve. Start-to-discharge and resealing pressure are to be observed through a water seal not over 100 mm in depth.

- 10.1.2.4. After recording the start-to-discharge pressure of the valve, the pressure is to be increased sufficiently above the start-to-discharge pressure to ensure unseating of the valve. The shut-off valve is then to be closed tightly and the water seal, as well as the pressure gauge, are to be observed closely. The pressure at which bubbles through the water seal cease is to be recorded as the resealing pressure of the valve.
- 10.1.3. Flow capacity of pressure relief valves — test No 2
- 10.1.3.1. The flow capacity of each of three samples of a pressure relief valve of a specific size, design, and setting shall fall within a range of 10 per cent of the highest observed capacity.
- 10.1.3.2. During flow capacity tests on each valve, there shall be no evidence of chattering or other abnormal operating condition.
- 10.1.3.3. The blow-down pressure of each valve shall be not less than 65 per cent of the initially recorded start-to-discharge pressure.
- 10.1.3.4. A flow capacity test on a pressure relief valve is to be conducted at a flow rating pressure of 120 per cent of the maximum set pressure.
- 10.1.3.5. A flow capacity test on a pressure relief valve is to be conducted by utilising a properly designed and calibrated orifice flowmeter of the flange type connected to a source of air supply of adequate capacity and pressure. Modifications of the flowmeter from that described herein, and an aerostatic flow medium other than air, may be used provided the end results are the same.
- 10.1.3.6. The flowmeter is to be arranged with sufficiently long lengths of pipe both preceding and following the orifice, or other arrangements including straightening vanes, to assure no disturbance at the orifice place for the ratios of orifice to pipe diameters to be employed.

Flanges between which the orifice plate is located and clamped are to be provided with pressure take-off lines connected to a manometer. This instrument indicates the pressure differential across the orifice plate and the reading is used in the flow calculation. A calibrated pressure gauge is to be installed in that portion of the meter pipe downstream of the orifice plate. This gauge indicates the flow pressure and the reading is also used in the flow calculation.

- 10.1.3.7. A temperature-indicating instrument is to be connected to the meter pipe downstream of the orifice plate to indicate the temperature of the air flowing to the safety valve. The reading of this instrument is to be integrated in the calculation to correct the temperature of the air flow to a 15 °C base temperature. A barometer is to be available for indicating the prevailing atmospheric pressure.

The reading of the barometer is to be added to the indicated air-flow gauge pressure. This absolute pressure is similarly to be integrated in the flow calculation. The air pressure to the flowmeter is to be controlled by a suitable valve installed in the air-supply piping ahead of the flowmeter. The pressure relief valve under test is to be connected to the discharge end of the flowmeter.

- 10.1.3.8. After all preparations for flow capacity tests have been made, the valve in the air-supply line is to be opened slowly and the pressure to the valve under test is to be increased to the appropriate flow rating pressure. During this interval, the pressure at which the valve 'pops' open is to be recorded as the popping pressure.
- 10.1.3.9. The predetermined flow rating pressure is to be maintained constant for a brief interval until the readings of the instruments become stabilised. Readings of the flow pressure gauge, pressure differential manometer, and the flowing air temperature indicator are to be recorded simultaneously. The pressure is then to be decreased until there is no further discharge from the valve.

The pressure at which this occurs is to be recorded as the blow-down pressure of the valve.

- 10.1.3.10. From the recorded data and the known orifice coefficient of the flowmeter, the air-flow capacity of the pressure relief valve tested is to be calculated using the following formula:

$$Q = \frac{F_b \times F_t \times \sqrt{0,1 \times h \times p}}{60}$$

Where:

Q = Flow capacity of pressure relief valve in m<sup>3</sup>/min. of air at 100 kPa absolute and 15 °C.

F<sub>b</sub> = Basic orifice factor of flowmeter at 100 kPa absolute and 15 °C.

HUF = Flowing air temperature factor to convert recorded temperature to base of 15 °C.

h = Differential pressure across orifice of meter in kPa.

p = Flowing air pressure to pressure relief valve in kPa absolute (recorded gauge pressure plus recorded barometric pressure).

60 = Denominator to convert equation from m<sup>3</sup>/hour to m<sup>3</sup>/min.

10.1.3.11. The average flow capacity of the three pressure relief valves rounded off to the nearest five units is to be taken as the flow capacity of the valve of that specific size, design and setting.

10.1.4. Recheck start-to-discharge and resealing pressures of pressure-relief-valves test No 3

10.1.4.1. Subsequent to flow capacity tests, the start-to-discharge pressure of a pressure relief valve shall be not less than 85 per cent, and the resealing pressure shall be not less than 80 per cent of the initial start-to-discharge and resealing pressures recorded under test No 1 of paragraph 10.1.2 above.

10.1.4.2. These tests are to be conducted approximately 1 hour after the flow capacity test, and the test procedure is to be the same as described under test No 1 of paragraph 10.1.2 above.

10.2. Operation test excess flow valve

10.2.1. An excess flow valve shall operate at not more than 10 per cent above, nor less than 20 per cent below the rated closing flow capacity specified by the manufacturer, and shall close automatically at a pressure differential across the valve of not more than 100 kPa during the operation tests described below.

10.2.2. Three samples of each size and style of valve are to be subjected to these tests. A valve intended for use only with liquid is to be tested with water, otherwise the tests are to be made both with air and with water. Except as indicated in paragraph 10.2.3 below, separate tests are to be run with each sample installed in vertical, horizontal and inverted positions. The tests with air to be made without piping or other restriction connected to the outlet of the tests sample.

10.2.3. A valve intended for installation in one position only may be tested only in that position.

10.2.4. The test with air is to be conducted by utilising a properly designed and calibrated orifice flowmeter of the flange type, connected to a source of air supply of adequate capacity and pressure.

10.2.5. The test sample is to be connected to the outlet of the flowmeter. A manometer or calibrated pressure-gauge reading in increments of not more than 3 kPa is to be installed on the upstream side of the test sample to indicate the closing pressure.

10.2.6. The test is conducted by slowly increasing the flow of air through the flowmeter until the check valve closes. At the instant of closing, the pressure differential across the flowmeter orifice and the closing pressure indicated by the gauge are to be recorded. The rate of flow at closing is then to be calculated.

10.2.7. Other types of flowmeters and a gas, other than air, may be used.

10.2.8. The test with water is to be conducted using a liquid flowmeter (or equivalent) installed in a piping system having sufficient pressure to provide the required flow. The system is to include an inlet piezometer or pipe at least one pipe size larger than the valve to be tested, with a flow control valve connected between the flowmeter and piezometer. A hose or hydrostatic relief valve, or both, may be used to reduce the effect of the pressure shock when the excess flow valve closes.

- 10.2.9. The test sample is to be connected to the outlet end of the piezometer. A manometer or calibrated pressure gauge of the retard type, which will permit readings in the range of 0 to 1 440 kPa is to be connected to a pressure take-off on the upstream side of the test sample to indicate the closing pressure. The connection is to be made using a length of rubber hose between the pressure gauge and the pressure take-off, with a valve installed at the gauge inlet to permit bleeding air from the system.
- 10.2.10. Prior to the test, the flow control valve is to be opened slightly, with the bleed valve at the pressure gauge open, to eliminate air from the system. The bleed valve is then to be closed and the test is conducted by slowly increasing the flow until the check valve closes. During the test the pressure gauge is to be positioned at the same level as the test sample. At the instant of closing, the rate of flow and closing pressure are to be recorded. When the excess flow valve is at cut-off position, the leakage or by-pass rate of flow is to be recorded.
- 10.2.11. An excess flow valve used in the assembly of a filling unit shall close automatically at a pressure differential of not more than 138 kPa when tested as described below.
- 10.2.12. Three samples of each size of valve are to be subjected to these tests. The tests are to be made with air, and separate tests are to be run with each sample mounted vertically and horizontally. The tests are to be conducted as described in paragraphs 10.2.4 to 10.2.7 above, with a filling unit hose coupling connected to the test sample and with the upper non-return valve held in the open position.
- 10.3. Charging-speed-test
- 10.3.1. Testing of the good function of the device limiting the filling degree of the container has to be performed by filling speeds of 20, 50 and 80 l/min. or to the maximum flow rate under an upstream pressure of 700 kPa abs.
- 10.4. Endurance test for the filling limiter
- The device limiting the filling degree of the container shall be capable of withstanding 6 000 complete filling cycles to the maximum filling degree.
- 10.4.1. Scope
- Any device limiting the filling degree of the container and operating by a float, after having been subjected to the tests verifying that:
- It limits the degree of filling of the container to 80 per cent or less of its capacity;
- It does not allow — at the cut-off position — any filling of the container at a rate exceeding 0,5 litre/minute,
- Shall be subjected to one of the test procedures laid down in paragraph 10.5.5 or 10.5.6 below to ensure that the device is constructed to withstand expected dynamic vibrational stresses and to ensure that performance degradations or malfunctions will not be produced by the service vibration environment.
- 10.5. Vibration test procedure
- 10.5.1. Equipment and mounting techniques
- The test item shall be attached to the vibration equipment by its normal mounting means, either directly to the vibration exciter or transition table, or by means of a rigid fixture capable of transmitting the specified vibration conditions. Equipment used to measure and/or record the acceleration level or amplitude level and the frequency shall have an accuracy of at least 10 per cent of the measured value.
- 10.5.2. Choice of procedure
- At the choice of the Type Approval Authority the tests shall be performed according to either procedure A described in paragraph 10.5.5 or procedure B described in paragraph 10.5.6 below.

## 10.5.3. General

The following tests shall be carried out along each of the three orthogonal axes of the test item.

## 10.5.4. Procedure A

## 10.5.4.1. Resonance search

Resonant frequencies of the filling limiter shall be determined by varying the frequency of applied vibration slowly through the specified range at reduced test levels but with sufficient amplitude to excite the item. Sinusoidal resonance search may be performed using the test level and cycling time specified for the cycling test, provided the resonance search time is included in the required cycling test time of paragraph 10.5.4.3 below.

## 10.5.4.2. Resonance dwell test

The test item shall be vibrated for 30 minutes along each axis at the most severe resonant frequencies determined in paragraph 10.5.5.1 below. The test level shall be 1,5 g (14,7 m/sec<sup>2</sup>). If more than four significant resonant frequencies are found for any one axis, the four most severe resonant frequencies shall be chosen for this test. If a change in the resonant frequency occurs during the test, its time of occurrence shall be recorded and immediately the frequency shall be adjusted to maintain the peak resonance condition. The final resonant frequency shall be recorded. The total dwell test time shall be included in the required cycling test time of paragraph 10.5.4.3 below.

## 10.5.4.3. Sinusoidal cycling test

The test item shall be sinusoidally vibrated for three hours along each of its orthogonal axes in accordance with:

An acceleration level of 1,5 g. (14,7 m/sec<sup>2</sup>),

A frequency range of 5 to 200 Hz,

A sweep time of 12 minutes.

The frequency of applied vibration shall be swept over the specified range logarithmically.

The specified sweep time is that of an ascending plus a descending sweep.

## 10.5.5. Procedure B

10.5.5.1. The test shall be performed on a sinusoidal vibrating bench, at a constant acceleration of 1,5 g and at frequencies ranging between 5 and 200 Hz. The test shall last for 5 hours for each of the axes specified in paragraph 10.5.4 above. The frequency band 5-200 Hz shall be covered in each of the two senses in 15 minutes.

10.5.5.2. Alternatively, in case of the test is not conducted by utilising a constant acceleration bench, the frequency band from 5 to 200 Hz has to be subdivided in 11 semi-octave bands, each of them covered by a constant amplitude, so that the theoretical acceleration is included between 1 and 2 g ( $g = 9,8 \text{ m/sec}^2$ ).

Vibration amplitudes for each band are as follows:

Amplitude in mm (crest value)	Frequency in Hz (for acceleration = 1g)	Frequency in Hz (for acceleration = 2g)
10	5	7
5	7	10

Amplitude in mm (crest value)	Frequency in Hz (for acceleration = 1g)	Frequency in Hz (for acceleration = 2g)
2,50	10	14
1,25	14	20
0,60	20	29
0,30	29	41
0,15	41	57
0,08	57	79
0,04	79	111
0,02	111	157
0,01	157	222

Each band shall be covered in both directions in 2 minutes, 30 minutes totally for each band.

#### 10.5.6. Specification

After having been subjected to one of the vibration test procedures described above the device shall show no mechanical failures and is deemed to conform to the vibration test requirements only in the case the values of its characteristic parameters:

Filling degree at the cut-off position,

Filling rate allowed at the cut-off position,

Do not exceed the prescribed limits and are not exceeding by more than 10 per cent the values preceding the vibration test procedure.

#### 11. LPG compatibility tests for synthetic materials

##### 11.1. A synthetic part in contact with LPG-liquid shall not show excessive volume change or loss of weight.

Resistance to n-pentane according to ISO 1817 with the following conditions:

- (a) Medium: n-pentane;
- (b) Temperature: 23 °C (tolerance acc. to ISO 1817);
- (c) Immersion period: 72 hours.

##### 11.2. Requirements:

Maximum change in volume 20 per cent

After storage in air with a temperature of 40 °C for a period of 48 hours the mass compared to the original value may not decrease more than 5 per cent.

#### 12. Corrosion resistance

##### 12.1. A metal LPG containing component shall comply with the leakage tests mentioned in 4, 5, 6 and 7 and after having been submitted to 144 hours salt spray test according to ISO 9227, with all connections closed.

Or an optional test:

- 12.1.1. A metal LPG containing component shall comply with the leakage tests mentioned in paragraphs 4, 5, 6 and 7 and after having been submitted to a salt spray test according to IEC 68-2-52 Kb: Salt Spray Fog Test.

Test procedure:

Before the test the component shall be cleaned according to the instructions of the manufacturer. All the connections shall be closed off. The component shall not be operated during the test.

Subsequently the component shall be submitted during 2 hours to spraying with a solution of salt, containing 5 per cent NaCl (mass per cent) with less than 0,3 per cent contamination and 95 per cent distilled or demineralised water, at a temperature of 20 °C. After the spraying the component is stored at temperature of 40 °C and 90-95 per cent relative humidity for 168 hours. This sequence shall be repeated 4 times.

After the test the component shall be cleaned and dried during 1 hour at 55 °C. The component shall now be conditioned to reference conditions during 4 hours, before submitting it to further testing.

- 12.2. A copper or brass LPG containing component shall comply with the leakage tests mentioned in paragraphs 4, 5, 6 and 7 and after having been submitted to 24 hours immersion in Ammonia according to ISO 6957 with all connections closed.

13. Resistance to dry heat

The test has to be done in compliance with ISO 188. The test piece has to be exposed to air at a temperature equal to the maximum operating temperature for 168 hours.

The allowable change in tensile strength should not exceed + 25 per cent.

The allowable change in ultimate elongation shall not exceed the following values:

Maximum increase 10 per cent

Maximum decrease 30 per cent

14. Ozone ageing

- 14.1. The test has to be in compliance with ISO 1431/1.

The test piece, which has to be stressed to 20 per cent elongation shall be exposed to air at 40 °C with an ozone concentration of 50 parts per hundred million during 72 hours.

- 14.2. No cracking of the test piece is allowed.

15. Creep

A non-metallic part containing liquid LPG shall comply with the leakage tests mentioned in paragraphs 5, 6 and 7 after having been submitted to a hydraulic pressure of 2,25 times the maximum operating pressure at a temperature of 120 °C during minimal 96 hours. Water or any other suitable hydraulic fluid may be used as a test medium.

16. Temperature cycle test

A non-metallic part containing liquid LPG shall comply with the leakage tests mentioned in paragraphs 5, 6 and 7 after having been submitted to a 96 hours temperature cycle from the minimum operating temperature up to the maximum operating temperature with a cycle time of 120 minutes, under maximum working pressure.

- 
17. Compatibility with heat exchange fluids of non-metallic parts
  - 17.1. Test samples shall be submerged in heat exchange medium for 168 hours at 90 °C; then they shall be dried for 48 hours at a temperature of 40 °C. The composition of the heat exchange medium used for the test is water/ethylene-glycol fluid of 50 %/50 %.
  - 17.2. The test is deemed to be satisfactory if the change in volume is less than 20 per cent, the change in mass is less than 5 per cent, the change in tensile strength is less than – 25 per cent and the change in elongation at break is within – 30 per cent and + 10 per cent.
-



## ANNEX 16

PROVISIONS REGARDING LPG IDENTIFICATION MARK FOR M<sub>2</sub> AND M<sub>3</sub> CATEGORY VEHICLES

The sign consists of a sticker which shall be weather resistant.

The colour and dimensions of the sticker shall fulfil the following requirements:

Colours:

Background: green  
Border: white or white reflecting  
Letters: white or white reflecting

Dimensions

Border width: 4 - 6 mm  
Character height:  $\geq 25$  mm  
Character thickness:  $\geq 4$  mm  
Sticker width: 110 - 150 mm  
Sticker height: 80 - 110 mm

The word 'LPG' shall be centred in the middle of the sticker.

---

## ANNEX 17

## PROVISIONS REGARDING IDENTIFICATION MARK FOR SERVICE COUPLING



The sign consists of a sticker which shall be weather resistant.

The colour and dimensions of the sticker shall fulfil the following requirements:

Colours:

Background: red  
Letters: white or white reflecting

Dimensions

Character height:  $\geq 5$  mm  
Character thickness:  $\geq 1$  mm  
Sticker width: 70 - 90 mm  
Sticker height: 20 - 30 mm

The text 'FOR SERVICE PURPOSES ONLY' shall be centred in the middle of the sticker.

---



ISSN 1977-0677 (electronic edition)  
ISSN 1725-2555 (paper edition)



**Publications Office of the European Union**  
2985 Luxembourg  
LUXEMBOURG

**EN**