

II

(Non-legislative acts)

ACTS ADOPTED BY BODIES CREATED BY INTERNATIONAL AGREEMENTS

Only the original UN/ECE texts have legal effect under international public law. The status and date of entry into force of this Regulation should be checked in the latest version of the UN/ECE status document TRANS/WP.29/343, available at: <http://www.unece.org/trans/main/wp29/wp29wgs/wp29gen/wp29fdocstts.html>

UN Regulation No 48 – Uniform provisions concerning the approval of vehicles with regard to the installation of lighting and light-signalling devices [2021/1718]

Incorporating all valid text up to:

Supplement 1 to the 07 series of amendments - Date of entry into force: 30 September 2021

CONTENTS

REGULATION

1. Scope
2. Definitions
3. Application for approval
4. Approval
5. General specifications
6. Individual specifications
7. Modifications and extensions of approval of the vehicle type or of the installation of its lighting and light signalling devices
8. Conformity of production
9. Penalties for non conformity of production
10. Production definitively discontinued
11. Names and addresses of Technical Services responsible for conducting approval tests and of Type Approval Authorities
12. Transitional provisions

ANNEXES

- 1 Communication
- 2 Arrangements of approval marks
- 3 Examples of lamp surfaces, axes, centres of reference, and angles of geometric visibility
- 4 Visibility of a red lamp to the front and visibility of a white lamp to the rear
- 5 States of loading to be taken into consideration in determining variations in the vertical orientation of the dipped beam headlamps

- 6 Measurement of the variation of dipped beam inclination as a function of load
- 7 Indication of the downward inclination of the dipped-beam headlamps cut-off referred to in paragraph 6.2.6.1.1. and downward inclination of the front fog lamp cut-off referred to in paragraph 6.3.6.1.2. of this Regulation
- 8 The controls for the headlamp levelling devices referred to in paragraph 6.2.6.2.2. of this Regulation
- 9 Control of conformity of production
- 10 Reserved
- 11 Visibility of conspicuity markings to the rear, front and side of a vehicle
- 12 Test drive
- 13 Automatic switching conditions dipped-beam headlamps
- 14 Observing area towards the apparent surface of manoeuvring and courtesy lamps
- 15 Gonio(photo)meter system used for the photometric measurements as defined in paragraph 2.34. of this Regulation

1. SCOPE

This Regulation applies to vehicles of categories M, N, and to their trailers (category O) ⁽¹⁾ with regard to the installation of lighting and light-signalling devices.

2. DEFINITIONS

2.1. General

2.1.1. The definitions given in this Regulation and its series of amendments in force at the time of application for type approval shall apply to the Light-Signalling Devices (LSD), Road Illumination Devices (RID) and Retro-Reflective Devices (RRD) Regulations.

2.1.2. References to standard (étalon) light source(s) shall refer to Regulations Nos. 37, 99 and 128 respectively, and to their series of amendments in force at the time of application for type approval.

2.1.3. "Approval of a vehicle" means the approval of a vehicle type with regard to the number and mode of installation of the lighting and light-signalling devices.

2.1.4. "Device" means an element or an assembly of elements used to perform one or more functions.

2.1.4.1. "Lighting function" means the light emitted by a device to illuminate the road and objects in the direction of vehicle movement.

2.1.4.2. "Light-signalling function" means the light emitted or reflected by a device to give to other road users visual information on the presence, identification and/or the change of movement of the vehicle.

2.1.5. "Lamp" means a device designed to illuminate the road or to emit a light signal to other road users. Rear registration plate lamps and retro-reflectors are likewise to be regarded as lamps. For the purpose of this Regulation, light-emitting rear registration plates, the service-door-lighting system according to the provisions of UN Regulation No. 107 on vehicles of categories M₂ and M₃ and external status indicator as defined in this Regulation are not considered as lamps.

2.1.6. "Change index" means a sequential number, starting from 0, specific to each lamp (function) covered by UN Regulations No. 148, No. 149 and No. 150. It indicates the number of times that the new series of amendments to the pertinent UN Regulation (No. 148, No. 149 and No. 150) have introduced higher stringency requirements for this lamp (function)."

2.2. Type definitions

2.2.1. "Vehicle type with regard to the installation of lighting and light-signalling devices" means vehicles which do not differ in the essential respects mentioned in paragraphs 2.2.1.1. to 2.2.1.4.

The following are likewise considered not to be "vehicles of a different type": vehicles which differ within the meaning of paragraphs 2.2.1.1. to 2.2.1.4., but not in such a way as to entail a change in the kind, number, positioning and geometric visibility of the lamps and the inclination of the dipped-beam prescribed for the vehicle type in question, and vehicles on which optional lamps are fitted or are absent:

2.2.1.1. The dimension and the external shape of the vehicle;

2.2.1.2. The number and positioning of the devices;

2.2.1.3. The headlamp-levelling system;

⁽¹⁾ As defined in the Consolidated Resolution on the Construction of Vehicles (R.E.3.), document ECE/TRANS/WP.29/78/Rev.6, para. 2 - www.unece.org/trans/main/wp29/wp29wgs/wp29gen/wp29resolutions.html

- 2.2.1.4. The suspension system.
- 2.3. Vehicle
- 2.3.1. "*Unladen vehicle*" means a vehicle without driver, crew, passengers and load, but with a full supply of fuel, spare wheel and the tools normally carried.
- 2.3.2. "*Laden vehicle*" means a vehicle loaded to its technically permissible maximum mass, as stated by the manufacturer, who shall also fix the distribution of this mass between the axles in accordance with the method described in Annex 5.
- 2.3.3. "*Extreme outer edge*" on either side of the vehicle, means the plane parallel to the median longitudinal plane of the vehicle and touching its lateral outer edge, disregarding the projection:
- 2.3.3.1. Of tyres near their point of contact with the ground, and of connections for tyre-pressure gauges;
- 2.3.3.2. Of any anti-skid devices mounted on the wheels;
- 2.3.3.3. Of devices for indirect vision;
- 2.3.3.4. Of side direction-indicator lamps, end-outline marker lamps, front and rear position lamps, parking lamps, retro-reflectors and side-marker lamps.
- 2.3.3.5. Of customs seals affixed to the vehicle, and of devices for securing and protecting such seals.
- 2.3.3.6. Of service-door lighting systems on vehicles of categories M₂ and M₃ as specified in paragraph 2.1.5.
- 2.3.4. "*Overall dimensions*" means the distance between the two vertical planes defined in paragraph 2.3.3. above.
- 2.3.4.1. "*Overall width*" means the distance between the two vertical planes defined in paragraph 2.3.3. above.
- 2.3.4.2. "*Overall length*" means the distance between the two vertical planes perpendicular to the median longitudinal plane of the vehicle and touching its front and rear outer edge, disregarding the projection:
- (a) Of devices for indirect vision;
- (b) Of end-outline marker lamps;
- (c) Of coupling devices, in the case of motor vehicles.
- For trailers in the "*overall length*" and in any measurement in length the drawbar shall be included, except when specifically excluded.
- 2.3.5. "*Operating tell-tale*" means a visual or auditory signal (or any equivalent signal) indicating that a device has been switched ON and is operating correctly or not.
- 2.3.6. "*Closed-circuit tell-tale*" means a visual (or any equivalent signal) indicating that a device has been switched ON, but not indicating whether it is operating correctly or not.
- 2.3.7. "*Ground*" means the surface on which the vehicle stands which should be substantially horizontal.
- 2.3.8. "*Movable components*" of the vehicle mean those body panels or other vehicle parts the position(s) of which can be changed by tilting, rotating or sliding without the use of tools. They do not include tiltable driver cabs of trucks.

- 2.3.9. "Normal position of use of a movable component" means the position(s) of a movable component specified by the vehicle manufacturer for the normal condition of use and the park condition of the vehicle.
- 2.3.10. "Normal condition of use of a vehicle" means:
- 2.3.10.1. For a motor vehicle, when the vehicle is ready to move with its propulsion system running and its movable components are in the normal position(s) as defined in paragraph 2.3.9.;
- 2.3.10.2. And for a trailer, when the trailer is connected to a drawing motor vehicle in the conditions as prescribed in paragraph 2.3.10.1. and its movable components are in the normal position(s) as defined in paragraph 2.3.9.
- 2.3.11. "Park condition of a vehicle" means:
- 2.3.11.1. For a motor vehicle, when the vehicle is at standstill and its propulsion system is not running and its movable components are in the normal position(s) as defined in paragraph 2.3.9.;
- 2.3.11.2. And for a trailer, when the trailer is connected to a drawing motor vehicle in the condition as described in paragraph 2.3.11.1. and its movable components are in the normal position(s) as defined in paragraph 2.3.9.
- 2.4. Lamps generalities
- 2.4.1. "Equivalent lamps" means lamps having the same function and authorized in the country in which the vehicle is registered; such lamps may have different characteristics from those installed on the vehicle when it is approved on condition that they satisfy the requirements of this Regulation.
- 2.4.2. "Independent lamps" means devices having separate apparent surfaces in the direction of the reference axis, ⁽²⁾ separate light sources and separate lamp bodies.
- 2.4.3. "Grouped lamps" means devices having separate apparent surfaces in the direction of the reference axis² and separate light sources, but a common lamp body.
- 2.4.4. "Combined lamps" means devices having separate apparent surfaces in the direction of the reference axis², but a common light source and a common lamp body.
- 2.4.5. "Reciprocally incorporated lamps" means devices having separate light sources or a single light source operating under different conditions (for example, optical, mechanical, electrical differences), totally or partially common apparent surfaces in the direction of the reference axis² and a common lamp body. ⁽³⁾
- 2.4.6. "Single-function lamp" means a part of a device which performs a single lighting or light-signalling function.
- 2.4.7. "Concealable lamp" means a lamp capable of being partly or completely hidden when not in use. This result may be achieved by means of a movable cover, by displacement of the lamp or by any other suitable means. The term "retractable" is used more particularly to describe a concealable lamp the displacement of which enables it to be inserted within the bodywork.

⁽²⁾ In the case of lighting devices for the rear registration plate and direction-indicators of categories 5 and 6, the "light-emitting surface" shall be used.

⁽³⁾ Examples to enable a decision regarding reciprocal incorporation of lamps can be found in Annex 3, Part 7.

- 2.4.8. "*Distance between two lamps*" which face in the same direction means the shortest distance between the two apparent surfaces in the direction of the reference axis. Where the distance between the lamps clearly meets the requirements of the Regulation, the exact edges of apparent surfaces need not be determined.
- 2.4.9. "*Optional lamp*" means a lamp, the installation of which is left to the discretion of the manufacturer.
- 2.4.10. "*Pair*" means the set of lamps of the same function on the left- and right-hand side of the vehicle.
- 2.4.10.1. "*Matched pair*" means the set of lamps of the same function on the left- and right-hand side of the vehicle, which, as a pair, complies with the photometric requirements.
- 2.4.11. "*Single and multiple lamps*"
- 2.4.11.1. "*A single lamp*" means:
- (a) A device or part of a device having one lighting or light-signalling function, one or more light source(s) and one apparent surface in the direction of the reference axis, which may be a continuous surface or composed of two or more distinct parts; or
 - (b) Any assembly of two lamps marked "D", whether identical or not, having the same function; or
 - (c) Any assembly of two independent retro-reflectors, whether identical or not, that have been approved separately; or
 - (d) Any interdependent lamp system composed of two or three interdependent lamps marked "Y" approved together and providing the same function.
- 2.4.11.2. "*Two lamps*" or "*an even number of lamps*" in the shape of a band or strip, means two lamps with a single light emitting surface, providing such a band or strip is placed symmetrically in relation to the median longitudinal plane of the vehicle.
- 2.4.12. "*Interdependent lamp system*" means an assembly of two or three interdependent lamps providing the same function.
- 2.4.12.1. "*Interdependent lamp marked "Y"*" means a device operating as part of an interdependent lamp system. Interdependent lamps operate together when activated, have separate apparent surfaces in the direction of the reference axis and separate lamp bodies, and may have separate light source(s).
- 2.4.13. "*Lamps marked "D"*" means independent lamps, approved as separate devices in such a way that they are allowed to be used either independently or in an assembly of two lamps to be considered as a "single lamp".
- 2.4.14. Headlamps of different "*Classes*" mean headlamps identified by particular photometric provisions.
- 2.4.15. Definitions with regard to Headlamps emitting a driving-beam and/or a symmetrical passing-beam for vehicles of categories L and T:
- 2.4.15.1. "*Additional lighting unit*" means the part of a headlamp system that provides the bend lighting. It is independent from the device that provides the principal passing beam, may consist of optical, mechanical and electrical components, and it may be grouped and/or reciprocally incorporated with other lighting or light-signalling devices.

- 2.4.16. Definitions with regard to retro-reflectors:
- 2.4.16.1. "*Retro-reflection*" means the reflection in which radiation is returned in directions close to the direction from which it came, this property being maintained even over wide variations of the direction of the incident radiation:
- 2.4.16.2. "*Retro-reflective device*" means an assembly ready for use and comprising one or more retro-reflective optical units; Retro-reflective devices are divided into classes according to their photometric characteristics: Class IA or IB, Class IIIA or IIIB, and Class IVA. Retro-reflective devices of Classes IB and IIIB are devices combined with other signal lamps which are not watertight and which are integrated into the body of a vehicle.
- 2.4.17. Definition with regard to Retro-reflective marking:
- 2.4.17.1. "*Retro-reflective marking material*" means a surface or a device from which, when directionally illuminated, a relatively large portion of the incident radiation is retro-reflected.
- 2.4.17.2. "*Rear marking plate*" means a plate faced with retro-reflective and fluorescent material or devices intended to increase the visibility and permit easy identification of heavy and long vehicles.
- 2.4.17.3. "*Slow moving vehicle (SMV) rear marking plate*" means a triangular plate with truncated corners with a characteristic pattern faced with retro-reflectors or retro-reflective materials or fluorescent material.
- 2.4.17.4. "*Sample unit*" means a complete retro-reflective device ready to be mounted on a vehicle and representative of current production.
- 2.4.17.5. "*Fluorescence*" means when certain substances are brought near to a source of ultraviolet or blue radiations, they emit radiations which are nearly always of longer wave-length than those producing the effect. This phenomenon is called fluorescence. By day and in twilight, fluorescent colours are brighter than normal colours because they reflect part of the light falling upon them, and in addition they emit light. At night they are not brighter than ordinary colours.
- 2.5. Lamps
- 2.5.1. "*Driving-beam (main-beam) headlamp*" means the lamp used to illuminate the road over a long distance ahead of the vehicle.
- 2.5.2. "*Passing-beam (dipped-beam) headlamp*" means the lamp used to illuminate the road ahead of the vehicle without causing undue dazzle or discomfort to oncoming drivers and other road-users.
- 2.5.2.1. "*Principal passing-beam (principal dipped-beam)*" means the dipped-beam produced without the contribution of infrared (IR) emitter and/or additional light sources for bend lighting.
- 2.5.3. "*Direction-indicator lamp*" means the lamp used to indicate to other road-users that the driver intends to change direction to the right or to the left. A direction-indicator lamp or lamps may also be used according to the provisions of UN Regulation No. 97 or No. 116.
- 2.5.4. "*Stop lamp*" means a lamp used to indicate to other road users to the rear of the vehicle that the longitudinal movement of the vehicle is intentionally retarded.
- 2.5.5. "*Rear-registration plate illuminating device*" means the device used to illuminate the space reserved for the rear registration plate; such a device may consist of several optical components.

- 2.5.6. "Front position lamp" means the lamp used to indicate the presence and the width of the vehicle when viewed from the front.
- 2.5.7. "Rear position lamp" means the lamp used to indicate the presence and width of the vehicle when viewed from the rear.
- 2.5.8. "Retro-reflector" means a device used to indicate the presence of a vehicle by the reflection of light emanating from a light source not connected to the vehicle, the observer being situated near the source.
- For the purposes of this Regulation the following are not considered as retro-reflectors:
- 2.5.8.1. Retro-reflecting number plates;
- 2.5.8.2. The retro-reflecting signals mentioned in the ADR (European Agreement concerning the international carriage of dangerous goods by road);
- 2.5.8.3. Other retro-reflective plates and signals which shall be used to comply with national requirements for use as regards certain categories of vehicles or certain methods of operation;
- 2.5.8.4. Retro-reflecting materials approved as Class D or E or F according to UN Regulations Nos. 104 or No. 150 and used for other purposes in compliance with national requirements."
- 2.5.9. "Conspicuity marking" means a device intended to increase the conspicuity of a vehicle, when viewed from the side or rear (or in the case of trailers, additionally from the front), by the reflection of light emanating from a light source not connected to the vehicle, the observer being situated near the source.
- 2.5.9.1. "Contour marking" means a conspicuity marking intended to indicate the horizontal and vertical dimensions (length, width and height) of a vehicle.
- 2.5.9.1.1. "Full contour marking" means a contour marking that indicates the outline of the vehicle by a continuous line.
- 2.5.9.1.2. "Partial contour marking" means a contour marking that indicates the horizontal dimension of the vehicle by a continuous line, and the vertical dimension by marking the upper corners.
- 2.5.9.2. "Line marking" means a conspicuity marking intended to indicate the horizontal dimensions (length and width) of a vehicle by a continuous line.
- 2.5.10. "Front fog lamp" means a lamp used to improve the illumination of the road ahead of the vehicle in case of fog or any similar condition of reduced visibility.
- 2.5.11. "Rear fog lamp" means a lamp used to make the vehicle more easily visible from the rear in dense fog.
- 2.5.12. "Reversing lamp" means the lamp used to illuminate the road to the rear of the vehicle and to warn other road-users that the vehicle is reversing or about to reverse.
- 2.5.13. "Parking lamp" means a lamp which is used to draw attention to the presence of a stationary vehicle in a built-up area. In such circumstances it replaces the front and rear position lamps.

- 2.5.14. "*End-outline marker lamp*" means the lamp fitted near to the extreme outer edge and as close as possible to the top of the vehicle and intended to indicate clearly the vehicle's overall width. This lamp is intended, for certain vehicles and trailers, to complement the vehicle's front and rear position lamps by drawing particular attention to its bulk.
- 2.5.15. "*Side marker lamp*" means a lamp used to indicate the presence of the vehicle when viewed from the side.
- 2.5.16. "*Daytime running lamp*" means a lamp facing in a forward direction used to make the vehicle more easily visible when driving during daytime.
- 2.5.17. "*Cornering lamp*" means a lamp used to provide supplementary illumination of that part of the road which is located near the forward corner of the vehicle at the side towards which the vehicle is going to turn.
- 2.5.18. "*Exterior courtesy lamp*" means a lamp used to provide supplementary illumination to assist the entry and exit of the vehicle driver and passenger or in loading operations;
- 2.5.19. "*Manoeuvring lamp*" means a lamp used to provide supplementary illumination to the side of the vehicle to assist during slow manoeuvres.
- 2.5.20. "*External status indicator*" means an optical signal mounted on the outside of the vehicle to indicate the status or the change of the status for Vehicle Alarm System (VAS), Alarm System (AS) and immobilizer of UN Regulations No. 97 and No. 116, when the vehicle is parked.
- 2.6. Signal
- 2.6.1. "*Hazard warning signal*" means the simultaneous operation of all of a vehicle's direction-indicator lamps to show that the vehicle temporarily constitutes a special danger to other road users.
- 2.6.2. "*Emergency stop signal*" means a signal to indicate to other road users to the rear of the vehicle that a high retardation force has been applied to the vehicle relative to the prevailing road conditions.
- 2.6.3. "*Rear-end collision alert signal (RECAS)*" means an automatic signal given by the leading vehicle to the following vehicle. It warns that the following vehicle needs to take emergency action to avoid a collision.
- 2.7. System
- 2.7.1. "*Aiming*" means the positioning of the beam or part thereof on an aiming screen according to the relevant criteria;
- 2.7.2. "*Adjustment*" means the use of the means provided by the system for vertical and/or horizontal aiming of the beam;
- 2.7.3. "*Bend lighting*" means a lighting function to provide enhanced illumination in bends.
- 2.7.4. "*Adaptive front lighting system*" (or "*AFS*") means a lighting device type-approved according to UN Regulations Nos. 123 or No. 149, providing beams with differing characteristics for automatic adaptation to varying conditions of use of the dipped-beam (passing-beam) and, if it applies, the main-beam (driving-beam).
- 2.7.4.1. "*Lighting unit*" means a light-emitting component designed to provide or contribute to one or more front lighting function(s) provided by the AFS.

- 2.7.4.2. "*Installation unit*" means an indivisible housing (lamp body) which contains one or more lighting unit(s).
- 2.7.4.3. "*Lighting mode*" or "*Mode*" of a front-lighting function provided by an AFS means a beam within the provisions either for one of the passing beam classes or for the main beam, designed and specified by the manufacturer for adaptation to dedicated vehicle and ambient conditions;
- 2.7.4.4. "*System control*" means that part(s) of the AFS receiving the AFS control signals from the vehicle and controlling the operation of the lighting units automatically.
- 2.7.4.5. "*AFS control signal*" (V, E, W, T) means the input to the AFS in accordance with the paragraph 6.22.7.4. of this Regulation.
- 2.7.4.6. "*Neutral state*" means the state of the AFS when a defined mode of the class C passing-beam ("basic passing-beam") or of the main beam in the maximum condition of activation, if any, is produced, and no AFS control signal applies.
- 2.7.4.7. "*Adaptive main-beam*" means a main-beam of the AFS that adapts its beam pattern to the presence of oncoming and preceding vehicles in order to improve the long-range visibility for the driver without causing discomfort, distraction or glare to other road users.
- 2.7.5. Definitions with regard to AFS:
- 2.7.5.1. "*Class*" of a passing beam (C, V, E or W) means the designation of a passing beam, identified by particular provisions according to UN Regulation No. 48 (For explanation only. The provisions of the passing-beam classes are dedicated to conditions as follows: C for the basic passing-beam, V for use in lit areas such as towns, E for use on roads such as motorways, W for use in adverse conditions such as wet road);
- 2.7.5.2. "*Bending mode*" means the designation of a mode of a front-lighting function with its illumination being laterally moved or modified (to obtain an equivalent effect), designed for bends, curves or intersections of the road, and, identified by particular photometric provisions;
- (a) "*Category 1 bending mode*" means a bending mode with horizontal movement of the kink of the cut-off;
- (b) "*Category 2 bending mode*" means a bending mode without horizontal movement of the kink of the cut-off;
- 2.7.5.3. "*Right side*" respectively "*left side*" means the combined total of the lighting units intended to be installed to that side of the longitudinal median plane of the vehicle, relative to its forward motion;
- 2.7.5.4. "*Signal*" means any AFS control signal or any additional control input to the system or a control output from the system to the vehicle;
- 2.7.5.5. "*Signal generator*" means a device, reproducing one or more of the signals for system tests;
- 2.7.5.6. "*Supply and operating device*" means one or more components of a system providing power to one or more parts of the system, including such as power and/or voltage control(s) for one or more light sources as e.g. electronic light source control gears;
- 2.7.5.7. "*System reference axis*" for an AFS means the intersection line of the vehicle's longitudinal median plane with the horizontal plane through the centre of reference of one lighting unit specified in the drawings accompanying the application for approval of the device;

- 2.7.5.8. "*Traffic-change function*" means any front-lighting function or a mode thereof, or part(s) thereof only, or any combination of these, intended to avoid glare and provide sufficient illumination in case where a vehicle being equipped with a system designed for one traffic direction only is temporarily used in a country with the opposite direction of traffic.
- 2.7.5.9. "*Substitute function*" means any specified front-lighting and/or front light-signalling, be it a front-lighting and/or a front light-signalling function, or a mode thereof, or part(s) thereof only, or any combination of it, intended to replace a front-lighting function/ mode in case of failure.
- 2.7.5.10. "*Functional unit*" means a part of a lighting unit providing a specific light distribution which may be used for different modes or classes. If used for the bending mode its light distribution may vary as a function of the T-signal (turn-radius); however, the light distribution shall be identical for a given T-signal (turn-radius) in all modes or classes.
- 2.7.6. Definitions with regard to switching and activation:
- 2.7.6.1. "*Switch ON*" means to manually or automatically operate an illuminating or signalling function to effectively emit light, irrespective of whether the function is operating correctly or not.
- 2.7.6.2. "*Switch OFF*" means to manually or automatically operate an illuminating or signalling function to stop emitting light, irrespective of whether the function is operating correctly or not.
- 2.7.6.3. "*Activate*" means to manually or automatically enable an illuminating or signalling function, irrespective of whether light is emitted or not (e.g. enable stand-by mode).
- 2.7.6.4. "*Deactivate*" means to manually or automatically disable an illuminating or signalling function, irrespective of whether light is emitted or not (e.g. disable stand-by mode).
- 2.7.6.5. "*Sequential activation*" means an electrical connection where the individual light sources of a lamp are wired such that they are switched ON in a predetermined sequence according to the relevant UN Regulations
- 2.7.7. "*Retro-reflecting optical unit*" means a combination of optical components producing retro-reflection.
- 2.8. Lens
- 2.8.1. "*Lens*" means the outermost component of the lamp (unit) which transmits light through the illuminating surface;
- 2.8.2. "*Coating*" means any product or products applied in one or more layers to the outer face of a lens;
- 2.8.3. "*Textured outer lens*" or "*Textured outer lens area*" means all or part of an outer lens, designed to modify or influence the propagation of light from the light source(s), such that the light rays are significantly diverted from their original direction.
- 2.9. Light sources
- 2.9.1. "*Light source*" means one or more elements for visible radiation, with a base for mechanical and electrical connection, possibly assembled with one or more components to control the elements for visible radiation.

- 2.9.1.1. "*Replaceable light source*" means a light source which is designed to be inserted in and removed from the holder of its device without tool.
- 2.9.1.2. "*Non-replaceable light source*" means a light source which can only be replaced by replacement of the device to which this light source is fixed.
- (a) In case of a light source module: a light source which can only be replaced by replacement of the light source module to which this light source is fixed;
- (b) In case of AFS: a light source which can only be replaced by replacement of the lighting unit to which this light source is fixed.
- 2.9.1.3. "*Light source module*" means an optical part of a device which is specific to that device. It contains one or more non-replaceable light sources and it may optionally contain one or more holders for approved replaceable light sources.
- 2.9.1.4. "*Filament light source*" (filament lamp) means a light source where the only element for visible radiation is one or more filaments producing thermal radiation.
- 2.9.1.5. "*Gas-discharge light source*" means a light source where the only element for visible radiation is a discharge arc producing electroluminescence.
- 2.9.1.6. "*Light-emitting diode (LED) light source*" means a light source where the only element for visible radiation is one or more solid state junctions producing electroluminescence possibly completed with one or more elements for fluorescence-based conversion.
- 2.9.1.6.1. "*LED substitute light source*" means a LED light source of a category which has a counterpart light source category producing light by another light generating technology.
- 2.9.1.7. "*LED module*" means a light source module containing as light sources only LEDs. However it may optionally contain one or more holders for approved replaceable light sources.
- 2.9.2. "*Electronic light source control gear*" means one or more components between supply and light source to control voltage and/ or electrical current of the light source.
- 2.9.2.1. "*Ballast*" means one or more components, either between supply and light source or integrated with the light source, to control the electrical current of a gas-discharge light source.
- 2.9.3. "*Variable intensity control*" means the device which automatically controls rear light signalling devices producing variable luminous intensities to assure the unvarying perception of their signals. The variable intensity control is part of the lamp, or part of the vehicle, or split between the said lamp and the vehicle.
- 2.10. Photometry
- 2.10.1. "*Objective luminous flux*" means:
- (a) In the case of a light source:
- The value of the objective luminous flux, not including any tolerances, as indicated in the relevant data sheet of the applicable light source Regulation according to which the light source is approved;
- (b) In the case of an LED module:
- The value of the objective luminous flux as indicated in the technical specification submitted with the LED module for approval of the lamp of which the LED module is a part;

2.10.2. "Light emitting surface" of a "lighting device", "light-signalling device" or a retro-reflector means the surface as declared in the request for approval by the manufacturer of the device on the drawing, see Annex 3 (see e.g. Parts 1, and 4).

This shall be declared according to one of the following conditions:

- (a) In the case where the outer lens is textured, the declared light emitting surface shall be all or part of the exterior surface of the outer lens;
- (b) In the case where the outer lens is non-textured the outer lens may be disregarded and the light emitting surface shall be as declared on the drawing, see Annex 3 (see e.g. Part 5).

2.10.3. "Illuminating surface" (see Annex 3).

2.10.3.1. "Illuminating surface of a lighting device" (paragraphs 2.5.1., 2.5.2., 2.5.10., 2.5.12. and 2.5.17.) means the orthogonal projection of the full aperture of the reflector, or in the case of headlamps with an ellipsoidal reflector of the "projection lens", on a transverse plane. If the lighting device has no reflector, the definition of paragraph 2.10.3.2. shall be applied. If the light emitting surface of the lamp extends over part only of the full aperture of the reflector, then the projection of that part only is taken into account.

In the case of a dipped-beam headlamp, the illuminating surface is limited by the apparent trace of the cut-off on to the lens. If the reflector and lens are adjustable relative to one another, the mean adjustment should be used.

In the case of AFS being installed: where a lighting function is produced by two or more simultaneously operated lighting units on a given side of the vehicle, the individual illuminating surfaces, taken together, constitute the illuminating surface to be considered (for example, in the figure of paragraph 6.22.4. below, the individual illuminating surfaces of the lighting units 8, 9 and 11, regarded together and taking into account their respective location, constitute the illuminating surface to be considered for the right hand side of the vehicle).

2.10.3.2. "Illuminating surface of a light-signalling device other than a retro-reflector" (paragraphs 2.5.3. to 2.5.7., 2.6.1., 2.5.11. and 2.5.13. to 2.5.16.) means the orthogonal projection of the lamp in a plane perpendicular to its axis of reference and in contact with the exterior light-emitting surface of the lamp, this projection being bounded by the edges of screens situated in this plane, each allowing only 98 per cent of the total luminous intensity of the light to persist in the direction of the axis of reference.

To determine the lower, upper and lateral limits of the illuminating surface only screens with horizontal or vertical edges shall be used to verify the distance to the extreme edges of the vehicle and the height above the ground.

For other applications of the illuminating surface, e.g. distance between two lamps or functions, the shape of the periphery of this illuminating surface shall be used. The screens shall remain parallel, but other orientations are allowed to be used.

In the case of a light-signalling device whose illuminating surface encloses either totally or partially the illuminating surface of another function or encloses a non-lighted surface, the illuminating surface may be considered to be the light emitting surface itself (see e.g. Annex 3, Parts 2, 3, 5 and 6).

2.10.3.3. "Illuminating surface of a retro-reflector" (paragraph 2.5.8.) means, as declared by the applicant during the component approval procedure for the retro-reflectors, the orthogonal projection of a retro-reflector in a plane perpendicular to its axis of reference and delimited by planes contiguous to the declared outermost parts of the retro-reflectors' optical system and parallel to that axis. For the purposes of determining the lower, upper and lateral edges of the device, only horizontal and vertical planes shall be considered.

- 2.10.4. The "*apparent surface*" for a defined direction of observation means, at the request of the manufacturer or his duly accredited representative, the orthogonal projection of:
- Either the boundary of the illuminating surface projected on the exterior surface of the lens;
- Or the light-emitting surface;
- Only in the case of a light-signalling device producing variable luminous intensities, its apparent surface that may be variable as specified in paragraph 2.9.3. shall be considered under all conditions permitted by the variable intensity control, if applicable.
- In a plane perpendicular to the direction of observation and tangential to the most exterior point of the lens.
- Different examples of the application of apparent surface can be found in Annex 3 to this Regulation.
- 2.10.5. "*Axis of reference*" (or "*reference axis*") means the characteristic axis of the lamp determined by the manufacturer (of the lamp) for use as the direction of reference ($H = 0^\circ$, $V = 0^\circ$) for angles of field for photometric measurements and for installing the lamp on the vehicle.
- 2.10.6. "*Centre of reference*" means:
- (a) The intersection of the axis of reference with the exterior light-emitting surface or
- (b) A point on or near a retro-reflective area
- which is designated to be the centre of the device for the purpose of specifying its performance; it is specified by the manufacturer of the lamp.
- 2.10.7. "*Angles of geometric visibility*" means the angles which determine the field of the minimum solid angle in which the apparent surface of the lamp is visible. That field of the solid angle is determined by the segments of the sphere of which the centre coincides with the centre of reference of the lamp and the equator is parallel with the ground. These segments are determined in relation to the axis of reference. The horizontal angles β correspond to the longitude and the vertical angles α to the latitude.
- 2.10.8. "*Photometric stability has occurred*" means the variation of the luminous intensity for the specified test point is less than 3 per cent within any 15 minute period.
- 2.10.9. "*Gonio(photo)meter system (if not otherwise specified in a particular Regulation)*" means a system used for the photometric measurements specified by the angular coordinates in degrees on a sphere with a vertical polar axis according to CIE publication No. 70, Vienna 1987, i.e. corresponding to a gonio(photo)meter system with a horizontal ("*elevation*") axis fixed to the ground and a second, moveable ("*rotation*") axis perpendicular to the fixed horizontal axis (see Annex 14 to this Regulation). *Note:* The above mentioned CIE publication specifies a procedure to correct the angular coordinates in the case where an alternative gonio(photo)meter system is used.
- 2.10.10. "*H plane*" means the horizontal plane containing the centre of reference of the lamp.
- 2.10.11. "*V plane*" means a vertical plane parallel to the median longitudinal plane of the vehicle and containing the center of reference of the lamp.
- 2.10.12. "*Transverse plane*" means a vertical plane perpendicular to the median longitudinal plane of the vehicle.

- 2.10.13. "Angle of divergence" means the angle between the straight lines connecting the centre of reference to the centre of the receiver and to the centre of the source of illumination.
- 2.10.14. "Illumination angle" means the angle between the axis of reference and the straight line connecting the centre of reference to the centre of the source of illumination.
- 2.10.15. "Angle of rotation" means the angle through which the retro-reflective device is rotated about its axis of reference starting from one given position.
- 2.10.16. "Angular diameter of the retro-reflective device" means the angle subtended by the greatest dimension of the visible area of the illuminating surface, either at the centre of the source of illumination or at the centre of the receiver.
- 2.10.17. "Illumination of the retro-reflective device" is the abbreviated expression used conventionally to designate the illumination measured in a plane perpendicular to the incident rays and passing through the centre of reference.
- 2.10.18. "Coefficient of luminous intensity (CIL)" means the quotient of the luminous intensity reflected in the direction considered, divided by the illumination of the retro-reflective device for given angles of illumination, divergence and rotation.

2.11. Colour

2.11.1. Colour of the light emitted from a device

- 2.11.1.1. "White" means the chromaticity coordinates (x,y) ⁽⁴⁾ of the light emitted that lie inside the chromaticity areas defined by the boundaries:

W ₁₂	green boundary	$y = 0,150 + 0,640 x$
W ₂₃	yellowish green boundary	$y = 0,440$
W ₃₄	yellow boundary	$x = 0,500$
W ₄₅	reddish purple boundary	$y = 0,382$
W ₅₆	purple boundary	$y = 0,050 + 0,750 x$
W ₆₁	blue boundary	$x = 0,310$

With intersection points:

	x	y
W ₁	0,310	0,348
W ₂	0,453	0,440
W ₃	0,500	0,440
W ₄	0,500	0,382
W ₅	0,443	0,382
W ₆	0,310	0,283

- 2.11.1.2. "Selective-yellow" means the chromaticity coordinates (x,y) ⁽⁴⁾ of the light emitted that lie inside the chromaticity areas defined by the boundaries:

SY ₁₂	green boundary	$y = 1,290 x - 0,100$
SY ₂₃	the spectral locus	
SY ₃₄	red boundary	$y = 0,138 + 0,580 x$

⁽⁴⁾ CIE Publication 15.2, 1986, Colorimetry, the CIE 1931 standard colorimetric observer.

SY ₄₅	yellowish white boundary	$y = 0,440$
SY ₅₁	white boundary	$y = 0,940 - x$

With intersection points:

	x	y
SY ₁	0,454	0,486
SY ₂	0,480	0,519
SY ₃	0,545	0,454
SY ₄	0,521	0,440
SY ₅	0,500	0,440

2.11.1.3. "Amber" means the chromaticity coordinates (x,y)⁴ of the light emitted that lie inside the chromaticity areas defined by the boundaries:

A ₁₂	green boundary	$y = x - 0,120$
A ₂₃	the spectral locus	
A ₃₄	red boundary	$y = 0,390$
A ₄₁	white boundary	$y = 0,790 - 0,670 x$

With intersection points:

	x	y
A ₁	0,545	0,425
A ₂	0,560	0,440
A ₃	0,609	0,390
A ₄	0,597	0,390

2.11.1.4. "Red" means the chromaticity coordinates (x,y)⁴ of the light emitted that lie inside the chromaticity areas defined by the boundaries:

R ₁₂	yellow boundary	$y = 0,335$
R ₂₃	the spectral locus	
R ₃₄	the purple line	(its linear extension across the purple range of colours between the red and the blue extremities of the spectral locus).
R ₄₁	purple boundary:	$y = 0,980 - x$

With intersection points:

	x	y
R ₁	0,645	0,335
R ₂	0,665	0,335
R ₃	0,735	0,265
R ₄	0,721	0,259

2.11.2. Night-time colour of the light retro-reflected from a device excluding retro-reflective tires according to UN Regulation No. 88

2.11.2.1. "White" means the chromaticity coordinates (x,y)⁴ of the light reflected that lie inside the chromaticity areas defined by the boundaries:

W ₁₂	blue boundary:	$y = 0,843 - 1,182 x$
W ₂₃	violet boundary	$y = 0,489 x + 0,146$
W ₃₄	yellow boundary	$y = 0,968 - 1,010 x$
W ₄₁	green boundary	$y = 1,442 x - 0,136$

With intersection points:

	x	y
W ₁	0,373	0,402
W ₂	0,417	0,350
W ₃	0,548	0,414
W ₄	0,450	0,513

2.11.2.2. "Yellow" means the chromaticity coordinates (x,y)⁴ of the light reflected that lie inside the chromaticity areas defined by the boundaries:

Y ₁₂	green boundary	$y = x - 0,040$
Y ₂₃	the spectral locus	
Y ₃₄	red boundary	$y = 0,200 x + 0,268$
Y ₄₁	white boundary	$y = 0,970 - x$

With intersection points:

	x	y
Y ₁	0,505	0,465
Y ₂	0,520	0,480
Y ₃	0,610	0,390
Y ₄	0,585	0,385

2.11.2.3. "Amber" means the chromaticity coordinates (x,y)⁴ of the light reflected that lie inside the chromaticity areas defined by the boundaries:

A ₁₂	green boundary	$y = 1,417 x - 0,347$
A ₂₃	the spectral locus	
A ₃₄	red boundary	$y = 0,390$
A ₄₁	white boundary	$y = 0,790 - 0,670 x$

With intersection points:

	x	y
A ₁	0,545	0,425
A ₂	0,557	0,442
A ₃	0,609	0,390

Y ₃	0,427	0,483
Y ₄	0,465	0,534

2.11.3.3. "Red" means the chromaticity coordinates (x,y)⁴ of the light reflected that lie inside the chromaticity areas defined by the boundaries:

R ₁₂	red boundary	$y = 0,346 - 0,053 x$
R ₂₃	purple boundary	$y = 0,910 - x$
R ₃₄	yellow boundary	$y = 0,350$
R ₄₁	the spectral locus	

With intersection points:

	x	y
R ₁	0,690	0,310
R ₂	0,595	0,315
R ₃	0,560	0,350
R ₄	0,650	0,350

2.11.4. Day-time colour of the fluorescent a device

2.11.4.1. "Red" means the chromaticity coordinates (x,y)⁴ of the light reflected that lie inside the chromaticity areas defined by the boundaries:

FR ₁₂	red boundary	$y = 0,346 - 0,053 x$
FR ₂₃	purple boundary	$y = 0,910 - x$
FR ₃₄	yellow boundary	$y = 0,315 + 0,047 x$
FR ₄₁	the spectral locus	

With intersection points:

	x	y
FR ₁	0,690	0,310
FR ₂	0,595	0,315
FR ₃	0,569	0,341
FR ₄	0,655	0,345

3. APPLICATION FOR APPROVAL

3.1. The application for approval of a vehicle type with regard to the installation of its lighting and light-signalling devices shall be submitted by the manufacturer or his duly accredited representative.

3.2. It shall be accompanied by the following documents and particulars in triplicate:

3.2.1. A description of the vehicle type with regard to the items mentioned in paragraphs 2.2.1.1. to 2.2.1.4. above, together with the restrictions on loading, particularly the maximum permissible load in the boot;

- 3.2.2. A list of the devices prescribed by the manufacturer for the lighting and light-signalling assembly. The list may include several types of device for each operation. Each type shall be duly identified (component, type-approval mark, name of manufacturer, etc.), in addition the list may include in respect of each function the additional annotation "or equivalent devices";
- 3.2.3. A layout drawing of the lighting and light-signalling equipment as a whole, showing the position of the various devices on the vehicle;
- 3.2.4. If necessary, in order to verify the conformity to the prescriptions of the present Regulation, layout drawing(s) for each individual lamp showing the illuminating surface as defined in paragraph 2.10.3., the light-emitting surface as defined in paragraph 2.10.2., the axis of reference as defined in paragraph 2.10.5. and the centre of reference as defined in paragraph 2.10.6. This information is not necessary in the case of the rear registration plate lamp (paragraph 2.5.5.);
- 3.2.5. A statement of the method used for the definition of the apparent surface (see paragraph 2.10.4.).
- 3.2.6. Where an AFS is fitted on the vehicle, the applicant shall submit a detailed description providing the following information:
- 3.2.6.1. The lighting functions and modes for which the AFS has been approved;
- 3.2.6.2. The related AFS control signals and their technical characteristics as defined according to Annex 10 to UN Regulation No. 123 or Annex 14 to UN Regulation No. 149.
- 3.2.6.3. The provisions being applied to adapt automatically the front lighting functions and modes according to paragraph 6.22.7.4. of this Regulation;
- 3.2.6.4. Special instruction, if any, for the inspection of the light sources and the visual observation of the beam;
- 3.2.6.5. The documents according to paragraph 6.22.9.2. of this Regulation;
- 3.2.6.6. The lamps that are grouped or combined with or reciprocally incorporated in the AFS;
- 3.2.6.7. Lighting units which are designed to comply with the requirements of paragraph 6.22.5. of this Regulation.
- 3.2.7. For vehicles of M and N categories a description of the electric power supply conditions for the devices indicated in paragraphs 2.5.1., 2.5.2., 2.5.4., 2.5.6. and 2.5.7. above, including, if applicable, information on a special power supply/electronic light source control gear, or variable intensity control.
- 3.2.8. At the discretion of the manufacturer, a statement indicating whether lamps approved for and equipped with LED substitute light sources are allowed to be installed on the vehicle or not and, if this is allowed, which lamps.
- 3.3. An unladen vehicle fitted with a complete set of lighting and light-signalling equipment, as prescribed in paragraph 3.2.2. above, and representative of the vehicle type to be approved shall be submitted to the Technical Service responsible for conducting approval tests.
- 3.4. The document provided in Annex 1 to this Regulation shall be attached to the type-approval documentation.

4. APPROVAL

- 4.1. If the vehicle type submitted for approval pursuant to this Regulation meets the requirements of the Regulation in respect of all the devices specified in the list, approval of that vehicle type shall be granted.
- 4.2. An approval number shall be assigned to each type approved. Its first two digits (at present 07, corresponding to the 07 series of amendments) shall indicate the series of amendments incorporating the most recent major technical amendments made to the Regulation at the time of issue of the approval. The same Contracting Party shall not assign this number to another vehicle type or to the same vehicle type submitted with equipment not specified in the list referred to in paragraph 3.2.2. above, subject to the provisions of paragraph 7 of this Regulation.
- 4.3. Notice of approval or of extension or refusal of approval or production definitively discontinued of a vehicle type/part pursuant to this Regulation shall be communicated to the Parties to the 1958 Agreement applying this Regulation, by means of a form conforming to the model in Annex 1 to this Regulation.
- 4.4. There shall be affixed, conspicuously and in a readily accessible place specified on the approval form, to every vehicle conforming to a vehicle type approved under this Regulation, an international approval mark consisting of:
- 4.4.1. A circle surrounding the letter "E" followed by the distinguishing number of the country which has granted approval; ⁽⁵⁾
- 4.4.2. The number of this Regulation, followed by the letter "R", a dash and the approval number to the right of the circle prescribed in paragraph 4.4.1.
- 4.5. If the vehicle conforms to a vehicle type approved, under one or more other Regulations annexed to the Agreement, in the country which has granted approval under this Regulation, the symbol prescribed in paragraph 4.4.1. need not to be repeated, in such a case the Regulation and approval numbers and the additional symbols of all the Regulations under which approval has been granted in the country which has granted approval under this Regulation shall be placed in vertical columns to the right of the symbol prescribed in paragraph 4.4.1.
- 4.6. The approval mark shall be clearly legible and be indelible.
- 4.7. The approval mark shall be placed close to or on the vehicle data plate affixed by the manufacturer.
- 4.8. Annex 2 to this Regulation gives examples of arrangements of approval marks.

5. GENERAL SPECIFICATIONS

- 5.1. The lighting and light-signalling devices shall be so fitted that under normal conditions of use as defined in paragraphs 2.3.10., 2.3.10.1. and 2.3.10.2. and notwithstanding any vibrations to which they may be subjected, they retain the characteristics prescribed by this Regulation and enable the vehicle to comply with the requirements of this Regulation. In particular, it shall not be possible for the lamps to be inadvertently maladjusted.
- 5.2. The illuminating lamps described in paragraphs 2.5.1., 2.5.2. and 2.5.10. shall be so installed that correct adjustment of their orientation can easily be carried out.

⁽⁵⁾ The distinguishing numbers of the Contracting Parties to the 1958 Agreement are reproduced in Annex 3 to the Consolidated Resolution on the Construction of Vehicles (R.E.3), document ECE/TRANS/WP.29/78/Rev. 6 - www.unece.org/trans/main/wp29/wp29wgs/wp29gen/wp29resolutions.html

- 5.2.1. In the case of headlamps fitted with measures to prevent discomfort to other road-users in a country where traffic operates on the side of the road opposite to that of the country for which the headlamp was designed, such measures shall be achieved automatically or by the vehicle user with the vehicle in the park condition without the need for special tools (other than those provided with the vehicle ⁽⁶⁾). Detailed instructions shall be provided by the vehicle manufacturer with the vehicle.
- 5.3. For all light-signalling devices, including those mounted on the side panels, the reference axis of the lamp when fitted to the vehicle shall be parallel to the bearing plane of the vehicle on the road; in addition it shall be perpendicular to the median longitudinal plane of the vehicle in the case of side retro-reflectors and of side-marker lamps and parallel to that plane in the case of all other signalling devices. In each direction a tolerance of $\pm 3^\circ$ shall be allowed. In addition, any specific instructions as regards fitting laid down by the manufacturer shall be complied with.
- 5.4. In the absence of specific instructions, the height and orientation of the lamps shall be verified with the vehicle unladen and placed on a flat, horizontal surface, in the condition defined in paragraphs 2.3.10., 2.3.10.1. and 2.3.10.2. and, in the case where an AFS is installed, with the system in its neutral state.
- 5.5. In the absence of specific instructions lamps constituting a pair shall:
- 5.5.1. Be fitted to the vehicle symmetrically in relation to the median longitudinal plane (this estimate to be based on the exterior geometrical form of the lamp and not on the edge of its illuminating surface referred to in paragraph 2.10.3.);
- 5.5.2. Be symmetrical to one another in relation to the median longitudinal plane, this requirement is not valid with regard to the interior structure of the lamp;
- 5.5.3. Satisfy the same colorimetric requirements and have substantially identical photometric characteristics. This shall not apply to a matched pair of Class F3 front fog lamps;
- 5.5.4. Have substantially identical photometric characteristics.
- 5.6. On vehicles whose external shape is asymmetrical the above requirements shall be satisfied so far as is possible.
- 5.7. Grouped, combined or reciprocally incorporated or single lamps
- 5.7.1. Lamps may be grouped, combined or reciprocally incorporated with one another provided that all requirements regarding colour, position, orientation, geometric visibility, electrical connections and other requirements, if any, are fulfilled.
- 5.7.1.1. The photometric and colorimetric requirements of a lamp shall be fulfilled when all other functions with which this lamp is grouped, combined or reciprocally incorporated are switched OFF.
- However, when a front or rear position lamp is reciprocally incorporated with one or more other function(s) which can be switched ON together with them, the requirements regarding colour of each of these other functions shall be fulfilled when the reciprocally incorporated function(s) and the front or rear position lamps are switched ON.
- 5.7.1.2. Stop lamps and direction-indicator lamps are not permitted to be reciprocally incorporated.

⁽⁶⁾ This does not apply to dedicated objects that may be added to the exterior of the headlamp.

- 5.7.1.3. Where stop lamps and direction-indicator lamps are grouped, the following conditions shall be met:
- 5.7.1.3.1. Any horizontal or vertical straight line passing through the projections of the apparent surfaces of these functions on a plane perpendicular to the reference axis, shall not intersect more than two borderlines separating adjacent areas of different colour;
- 5.7.1.3.2. Their apparent surfaces in the direction of the reference axis, based upon the areas bounded by the outline of their light emitting surfaces, do not overlap.

5.7.2. Single lamps

- 5.7.2.1. Single lamps as defined in paragraph 2.4.11.1., subparagraph (a), the apparent surface of which is composed of two or more distinct parts, shall be installed in such a way that:
- (a) Either the total area of the projection of the distinct parts of the apparent surface in the direction of the reference axis on a plane tangent to the exterior surface of the outer lens and perpendicular to the reference axis shall occupy not less than 60 per cent of the smallest quadrilateral circumscribing the projection of the said apparent surface in the direction of the reference axis; or
- (b) The minimum distance between the facing edges of two adjacent/tangential distinct parts of the apparent surface in the direction of the reference axis shall not exceed 75 mm when measured perpendicularly to the reference axis.

These requirements shall not apply to a single retro-reflector.

- 5.7.2.2. Single lamps as defined in paragraph 2.4.11.1., subparagraph (b) or (c), composed of two lamps marked "D" or two independent retro reflectors, shall be installed in such a way that:
- (a) Either the projection of the apparent surfaces in the direction of the reference axis of the two lamps or retro reflectors occupies not less than 60 per cent of the smallest quadrilateral circumscribing the projections of the said apparent surfaces in the direction of the reference axis; or
- (b) The minimum distance between the facing edges of the apparent surfaces in the direction of the reference axis of two lamps or two independent retro reflectors does not exceed 75 mm when measured perpendicularly to the reference axis.

- 5.7.2.3. Single lamps as defined in paragraph 2.4.11.1., subparagraph (d) shall fulfil the requirements of paragraph 5.7.2.1.

Where two or more lamps and/or two or more separate apparent surfaces are included into the same lamp body and/or have a common outer lens these shall not be considered as an interdependent lamp system.

However, a lamp in the shape of a band or strip may be part of an interdependent lamp system.

- 5.7.2.4. Two lamps or an even number of lamps in the shape of a band or strip shall be placed symmetrically in relation to the median longitudinal plane of the vehicle, extending on both sides to within at least 0.4 m of the extreme outer edge of the vehicle, and are not less than 0.8 m long; the illumination of such a surface shall be provided by not less than two light sources placed as close as possible to the ends; the light-emitting surface may be constituted by a number of juxtaposed elements on condition that these individual light-emitting surfaces, when projected on a transverse plane fulfil the requirements of paragraph 5.7.2.1.

- 5.8. The maximum height above the ground shall be measured from the highest point and the minimum height from the lowest point of the apparent surface in the direction of the reference axis.

Where the (maximum and minimum) height above the ground clearly meets the requirements of the Regulation, the exact edges of any surface need not be determined.

- 5.8.1. For the purposes of reducing the geometric visibility angles, the position of a lamp with regard to height above the ground, shall be measured from the H plane.
- 5.8.2. In the case of dipped-beam headlamp, the minimum height in relation to the ground is measured from the lowest point of the apparent surface in the direction of the reference axis independent of its utilization.
- 5.8.3. The position, as regards width, will be determined from that edge of the apparent surface in the direction of the reference axis which is the furthest from the median longitudinal plane of the vehicle when referred to the overall width, and from the inner edges of the apparent surface in the direction of the reference axis when referred to the distance between lamps.

Where the position, as regards width, clearly meets the requirements of the Regulation, the exact edges of any surface need not be determined.

- 5.9. In the absence of specific instructions, the photometric characteristics (e.g. intensity, colour, apparent surface, etc.) of a lamp shall not be intentionally varied during the period when the lamp is switched ON.
- 5.9.1. Direction-indicator lamps, the vehicle-hazard warning signal, amber side-marker lamps complying with paragraph 6.18.7. below, and the emergency stop signal shall be flashing lamps.
- 5.9.2. The photometric characteristics of any lamp may vary:
- (a) In relation to the ambient light;
 - (b) As a consequence of other lamps being switched ON or OFF; or
 - (c) When the lamps is being used to provide another lighting function; provided that any variation in the photometric characteristics is in compliance with the technical provisions for the lamp concerned.
- 5.9.3. The photometric characteristics of a direction indicator lamp of categories 1, 1a, 1b, 2a or 2b may be varied during a flash by sequential activation of light sources as specified in paragraph 5.6. of UN Regulation No. 6. or paragraph 5.6.11. of UN Regulation No. 148.

This provision shall not apply when direction indicator lamps of categories 2a and 2b are operated as emergency stop signal according to paragraph 6.23.1. of this Regulation.

- 5.10. No red light which could give rise to confusion shall be emitted from a lamp as defined in paragraph 2.1.5. in a forward direction and no white light which could give rise to confusion, shall be emitted from a lamp as defined in paragraph 2.1.5. in a rearward direction. No account shall be taken of lighting devices fitted for the interior lighting of the vehicle. In case of doubt, this requirement shall be verified as follows:
- 5.10.1. For the visibility of red light towards the front of a vehicle, with the exception of a red rearmost side-marker lamp, there shall be no direct visibility of the apparent surface of a red lamp if viewed by an observer moving within Zone 1 in a transverse plane situated 25 m in front of the vehicle (see Annex 4);
- 5.10.2. For the visibility of white light towards the rear of a vehicle, with the exception of reversing lamps and white side conspicuity markings, there shall be no direct visibility of the apparent surface of a white lamp if viewed by an observer moving within Zone 2 in a transverse plane situated 25 m behind the vehicle (see Annex 4);

- 5.10.3. In their respective planes, the zones 1 and 2 explored by the eye of the observer are bounded:
- 5.10.3.1. In height, by two horizontal planes 1 m and 2.2 m respectively above the ground;
- 5.10.3.2. In width, by two vertical planes which, forming to the front and to the rear respectively an angle of 15° outwards from the vehicle's median longitudinal plane, pass through the point or points of contact of vertical planes parallel to the vehicle's median longitudinal plane delimiting the vehicle's overall width; if there are several points of contact, the foremost shall correspond to the forward plane and the rearmost to the rearward plane.
- 5.11. The electrical connections shall be such that the front and rear position lamps, the end-outline marker lamps, if they exist, the side-marker lamps, if they exist, and the rear registration plate lamp can only be switched ON and OFF simultaneously.
- 5.11.1. This requirement does not apply while one or more of the following conditions exist:
- (a) Front and rear position lamps, as well as side-marker lamps when combined or reciprocally incorporated with said lamps, are switched ON as parking lamps;
 - (b) Side-marker lamps flash in conjunction with direction indicators;
 - (c) Daytime running lamps are switched ON;
 - (d) Front position lamps function is substituted under the provisions of paragraph 5.12.1. below.
- 5.11.2. In the case of an interdependent lamp system, all light sources shall be switched ON and OFF simultaneously.
- 5.12. The electrical connections shall be such that the main-beam and dipped-beam headlamps and the front fog lamps cannot be switched ON unless the lamps referred to in paragraph 5.11. are also switched ON. This requirement shall not apply, however, to main-beam or dipped-beam headlamps when their luminous warnings consist of the intermittent lighting up at short intervals of the main-beam headlamp or the intermittent lighting up at short intervals of the dipped-beam headlamp or the alternate lighting up at short intervals of the main-beam and dipped-beam headlamps.
- 5.12.1. The dipped-beam headlamps and/or the main-beam headlamps and/or the front fog lamps may substitute the function of the front position lamps, provided that:
- 5.12.1.1. Their electrical connections are such that in case of failure of any of these lighting devices the front position lamps are automatically switched ON again; and
- 5.12.1.2. The substituting lamp/function meets, for the respective position lamp, the requirements concerning:
- (a) The geometric visibility prescribed for the front position lamps in 6.9.5; and
 - (b) The minimum photometric values according to the angles of light distribution; and
- 5.12.1.3. Appropriate evidence demonstrating compliance with the requirements indicated in paragraph 5.12.1.2. above is provided in the test reports of the substituting lamp.
- 5.13. Tell-tale
- Where a closed-circuit tell-tale is prescribed by this Regulation it may be replaced by an "operating" tell-tale.

5.14. Concealable lamps

5.14.1. The concealment of lamps shall be prohibited, with the exception of the main-beam headlamps, the dipped-beam headlamps and the front fog lamps, which may be concealed when they are not in use.

5.14.2. In the event of any failure affecting the operation of the concealment device(s) the lamps shall remain in the position of use, if already in use, or shall be capable of being moved into the position of use without the aid of tools.

5.14.3. It shall be possible to move the lamps into the position of use and to switch them ON by means of a single control, without excluding the possibility of moving them into the position of use without switching them ON. However, in the case of grouped main-beam and dipped-beam headlamps, the control referred to above is required only to activate the dipped-beam headlamps.

5.14.4. It shall not be possible deliberately, from the driver's seat, to stop the movement of switched ON lamps before they reach the position of use. If there is a danger of dazzling other road users by the movement of the lamps, they may light up only when they have reached their position of use.

5.14.5. When the concealment device has a temperature of $-30\text{ }^{\circ}\text{C}$ to $+50\text{ }^{\circ}\text{C}$ the headlamps shall be capable of reaching the position of use within three seconds of initial operation of the control.

5.15. The colours of the light emitted by the lamps ^(?) are the following:

Main-beam headlamp:	White
Dipped-beam headlamp:	White
Front fog lamp:	White or selective yellow
Reversing lamp:	White
Direction-indicator lamp:	Amber
Hazard warning signal:	Amber
Stop lamp:	Red
Emergency stop signal :	Amber or red
Rear-end collision alert signal:	Amber
Rear registration plate lamp:	White
Front position lamp:	White
Rear position lamp:	Red
Rear fog lamp:	Red
Parking lamp:	White in front, red at the rear, amber if reciprocally incorporated in the side direction-indicator lamps or in the side-marker lamps.
Side-marker lamp:	Amber; however the rearmost side- marker lamp can be red if it is grouped or combined or reciprocally incorporated with the rear position lamp, the rear end-outline marker lamp, the rear fog lamp, the stop lamp or is grouped or has part of the light emitting surface in common with the rear retro-reflector.

^(?) Measurement of the chromaticity coordinates of the light emitted by the lamps is not part of this regulation.

End-outline marker lamp:	White in front, red at the rear
Daytime running lamp:	White
Rear retro-reflector, non- triangular:	Red
Rear retro-reflector, triangular:	Red
Front retro-reflector, non- triangular:	Identical to incident light ⁽⁸⁾
Side retro-reflector, non- triangular:	Amber; however the rearmost side retro-reflector can be red if it is grouped or has part of the light emitting surface in common with the rear position lamp, the rear end outline marker lamp, the rear fog lamp, the stop-lamp, the red rearmost side-marker lamp or the rear retro-reflector, non- triangular.
Cornering lamp:	White
Conspicuity marking:	White to the front; White or yellow to the side; Red or yellow to the rear. ⁽⁹⁾
Adaptive front-lighting systems (AFS):	White
Exterior courtesy lamp:	White
Manoeuvring lamp:	White

5.16. Number of lamps

5.16.1. The number of lamps mounted on the vehicle shall be equal to the number indicated in the individual specifications of this Regulation.

5.17. Any lamp may be installed on movable components provided that the conditions specified in paragraphs 5.18., 5.19. and 5.20. are fulfilled.

5.18. Rear position lamps, rear direction-indicators and rear retro-reflectors, triangular as well as non-triangular, may be installed on movable components only:

5.18.1. If at all fixed positions of the movable components the lamps on the movable components meet all the position, geometric visibility, colorimetric and photometric requirements for those lamps.

5.18.2. In the case where the functions referred to in paragraph 5.18. are obtained by an assembly of two lamps marked "D" (see paragraph 2.4.11.1.), only one of the lamps needs to meet the position, geometric visibility and photometric requirements for those lamps at all fixed positions of the movable components.

or

5.18.3. Where additional lamps for the above functions are fitted and are switched ON, when the movable component is in any fixed open position, provided that these additional lamps satisfy all the position, geometric visibility and photometric requirements applicable to the lamps installed on the movable component.

⁽⁸⁾ Also known as white or colourless retro-reflector.

⁽⁹⁾ Nothing in this Regulation shall preclude the Contracting Parties applying this Regulation from allowing the use of white conspicuity markings to the rear in their territories.

5.18.4. In the case where the functions referred to in paragraph 5.18. are obtained by an interdependent lamp system either of the following conditions shall apply:

(a) Should the complete interdependent lamp system be mounted on the moving component(s), the requirements of paragraph 5.18.1. shall be satisfied. However, additional lamps for the above functions may be switched ON, when the movable component is in any fixed open position, provided that these additional lamps satisfy all the position, geometric visibility, colorimetric and photometric requirements applicable to the lamps installed on the movable component;

or

(b) Should the interdependent lamp system be partly mounted on the fixed component and partly mounted on a movable component, with the exception of direction indicator lamps, the interdependent lamp(s) specified by the Applicant during the device approval procedure shall meet all the position, outwards geometric visibility, colorimetric and photometric requirements for those lamps, at all fixed positions of the movable component(s).

The inwards geometric visibility requirement(s) is(are) deemed to be satisfied if this(these) interdependent lamp(s) still conform(s) to the photometric values prescribed in the field of light distribution for the approval of the device, at all fixed positions of the movable component(s).

For direction indicator lamps, the interdependent lamp(s) specified by the Applicant during the device approval procedure shall meet all the position, geometric visibility, photometric and colorimetric requirements at all fixed positions of the movable component(s). This does not apply where, to fulfil or complete the geometric visibility angle, additional lamps are switched ON when the movable component is in any fixed open position, provided that these additional lamps satisfy all the position, photometric and colorimetric requirements applicable to the direction indicator lamps installed on the movable component.

5.19. When the movable components are in a position other than a "normal position of use", the devices installed on them shall not cause undue discomfort to road users.

5.20. When a lamp is installed on a movable component and the movable component is in the "normal position(s) of use", the lamp shall always return to the position(s) specified by the manufacturer in accordance with this Regulation. In the case of dipped-beam headlamps and front fog lamps, this requirement shall be considered satisfied if, when the movable components are moved and returned to the normal position 10 times, no value of the angular inclination of these lamps, relative to its support, measured after each operation of the movable component, differs by more than 0.15 per cent from the average of the 10 measured values. If this value is exceeded each limit specified in paragraph 6.2.6.1.1. shall then be modified by this excess to decrease the allowed range of inclinations when checking the vehicle according to Annex 6.

5.21. The apparent surface in the direction of the reference axis of front and rear position lamps, front and rear direction-indicator lamps and retro-reflectors shall not be hidden more than 50 per cent by any movable component, with or without a light-signalling device installed on it, in any fixed position different from the "normal position of use".

Fixed position of a movable component means the stable or natural rest position(s) of the movable component specified by the vehicle manufacturer, whether locked or not.

If the above requirement is not practicable:

5.21.1. Additional lamps satisfying all the position, geometric visibility, colorimetric and photometric requirements for the above indicated lamps shall be switched ON when the apparent surface in the direction of the reference axis of these lamps is more than 50 per cent hidden by the movable component;

- 5.21.2. A remark in the communication form (item 10.1. of Annex 1) shall inform other Administrations that more than 50 per cent of the apparent surface in the direction of the reference axis can be hidden by the movable components; and
- A notice in the vehicle shall inform the user that in certain position(s) of the movable components other road users shall be warned of the presence of the vehicle on the road; for example by means of a warning triangle or other devices according to national requirements for use on the road.
- 5.21.3. Paragraph 5.21.2. does not apply to retro-reflectors.
- 5.22. With the exception of retro-reflectors, a lamp even bearing an approval mark is deemed not to be present when it cannot be made to operate by the sole installation of a light source and/or a fuse.
- 5.23. Lamps approved with light source(s) according to UN Regulation No. 37, except when such light sources are used as non-replaceable light source(s) as defined in paragraph 2.9.1.2., shall be fitted in a vehicle in such a way that the light source can be correctly replaced without the need for expert assistance and without the need for special tools, other than those provided with the vehicle by the manufacturer. The vehicle manufacturer shall provide with the vehicle a detailed description of the procedure for replacement.
- 5.23.1. In the case where a light source module includes a holder for an approved replaceable light source according to Regulation No. 37, this light source shall be replaceable as required in paragraph 5.23. above.
- 5.24. Any temporary fail-safe replacement of the light-signalling function of a rear position lamp is allowed, provided that the replacement function in case of a failure is similar in colour, main intensity and position to the function that has ceased to operate and provided that the replacement device remains operational in its original safety function. During replacement, a tell-tale on the dashboard (paragraph 2.3.5. of this Regulation) shall indicate occurrence of a temporary replacement and need for repair.
- 5.25. Where an AFS is fitted, it shall be considered equivalent to a pair of dipped-beam headlamps and, if it provides main-beam function(s), it shall be considered equivalent to a pair of main-beam headlamps.
- 5.26. Rear direction-indicator lamps, rear position lamps, stop lamps (except stop lamps of category S4) and rear fog lamps with variable luminous intensity control are allowed, which respond simultaneously to at least one of the following external influences: ambient lighting, fog, snowfall, rain, spray, dust clouds, contamination of the light emitting surface, provided that their prescribed intensity relationship is maintained throughout variation transitions. No sharp variation of intensity shall be observed during transition. Stop lamps of category S4 may produce variable luminous intensity independent from the other lamps. It may be possible for the driver to set the functions above to luminous intensities corresponding to their steady category and to return them to their automatic variable category.
- 5.27. For vehicles of M and N categories the applicant shall demonstrate to the Technical Service responsible for type approval testing that the electric power supply conditions for the devices indicated in 2.5.1., 2.5.2., 2.5.4., 2.5.6. and 2.5.7. above comply, when the electrical system of the vehicle is in a constant voltage operating condition, representative for the relevant category of powered vehicle as specified by the applicant, with the following provisions:
- 5.27.1. The voltage supplied at the terminals of devices which, according to their type approval documentation, have been tested by the application of a special power supply/electronic light source control gear, or in a secondary operating mode or at a voltage requested by the applicant, shall not exceed the voltage specified for the relevant devices or functions as they have been approved.

- 5.27.2. In all cases of electric power supply conditions not covered by paragraph 5.27.1., the voltage at the terminals of the device(s) or function(s) shall not exceed 6.75 V (6 Volt-Systems), 13.5 V (12 Volt-Systems) or 28 V (24 Volt-Systems) by more than 3 per cent. The means of controlling the maximum voltage at the terminals of the device may, for convenience, be located within the body of the device.
- 5.27.3. The provisions of paragraphs 5.27.1. and 5.27.2. shall not apply to devices which include an electronic light source control gear or a variable intensity control being part of the device.
- 5.27.4. A report shall be attached to the approval documentation describing the methods used to demonstrate compliance and the results obtained.
- 5.28. General provisions relating to geometric visibility
- 5.28.1. There shall be no obstacle on the inside of the angles of geometric visibility to the propagation of light from any part of the apparent surface of the lamp observed from infinity. However, no account is taken of obstacles, if they were already presented when the lamp was type-approved.
- 5.28.2. If measurements are taken closer to the lamp, the direction of observation shall be shifted parallel to achieve the same accuracy.
- 5.28.3. If, when the lamp is installed, any part of the apparent surface of the lamp is hidden by any further parts of the vehicle, proof shall be furnished that the part of the lamp not hidden by obstacles still conforms to the photometric values prescribed for the approval of the device.
- 5.28.4. When the vertical angle of geometric visibility below the horizontal may be reduced to 5° (lamp at less than 750 mm above the ground measured according to the provisions of paragraph 5.8.1. above) the photometric field of measurements of the installed optical unit may be reduced to 5° below the horizontal.
- 5.28.5. In the case of an interdependent lamp system the geometric visibility requirements shall be fulfilled when all its interdependent lamps are operated together.
- 5.29. A LED module does not need to be replaceable, if so stated in the communication sheet of the component type approval.
- 5.30. All lamps (devices) shall, where applicable, be type approved according to the corresponding device UN Regulations as specified in the relevant subparagraphs of paragraph 6. of this Regulation when installed on a vehicle.
- 5.31. Lamps installed on a vehicle which is approved according to this Regulation and approved for one or more replaceable light source categories according to UN Regulations Nos. 37, 99 or 128, shall be fitted with light sources approved according to these light source categories only.
- This requirement does not concern light source modules, LED modules and non-replaceable light sources, except for when they are required to be approved by the applicable UN Regulation.
- 5.32. External status indicator
- One external status indicator for Vehicle Alarm System (VAS), Alarm System (AS) and immobilizer is allowed if:
- The light intensity in any direction does not exceed 0.5 cd;
 - The colour of the light emitted is white, red or amber;
 - The area of the apparent surface is not larger than 20 cm².

Up to two external status indicators for Vehicle Alarm System (VAS), Alarm System (AS) and immobiliser are allowed on a vehicle provided that the apparent surface does not exceed 10 cm² per indicator.

5.33. A device type approved according to any preceding series of amendments to UN Regulations Nos. 148 and/or 149 and/or 150 is deemed equivalent to one approved according to the latest series of amendments to the pertinent UN Regulations Nos. 148 and/or 149 and/or 150, when the change indexes (defined in paragraph 2.1.6.) related to each individual lamp (function) do not differ. In this case such a device may be fitted on the vehicle to be type approved without any update of the device type approval documents and device markings.

5.34. The use of lamps approved for and equipped with LED substitute light source(s), is allowed exclusively in the case where the statement indicated in paragraph 3.2.8. is present and positive.

To verify that this statement is respected, both at the type approval and in the conformity of production verification, the presence of the marking on the lamps related to the use of LED substitute light source(s) shall be checked.

6. INDIVIDUAL SPECIFICATIONS

6.1. Main-beam headlamp (UN Regulations Nos. 98, 112 or 149)

6.1.1. Presence

Mandatory on motor vehicles. Prohibited on trailers.

6.1.2. Number

Two or four, type approved according to

(a) UN Regulation No. 98 or 112, excluding Class A headlamp;

or

(b) UN Regulation No. 149, Classes B and D headlamps only.

For vehicles of the category N₃: Two extra main-beam headlamps may be installed.

Where a vehicle is fitted with four concealable headlamps the installation of two additional headlamps shall only be authorized for the purpose of light-signalling, consisting of intermittent switching ON, at short intervals (see paragraph 5.12. above) in daylight.

6.1.3. Arrangement

No individual specifications.

6.1.4. Position

6.1.4.1. In width: No individual specifications.

6.1.4.2. In height: No individual specifications.

6.1.4.3. In length: At the front of the vehicle. This requirement shall be deemed to be satisfied if the light emitted does not cause discomfort to the driver either directly or indirectly through the devices for indirect vision and/or other reflecting surfaces of the vehicle.

6.1.5. Geometric visibility

The visibility of the illuminating surface, including its visibility in areas which do not appear to be illuminated in the direction of observation considered, shall be ensured within a divergent space defined by generating lines based on the perimeter of the illuminating surface and forming an angle of not less than 5° with the axis of reference of the headlamp. The origin of the angles of geometric visibility is the perimeter of the projection of the illuminating surface on a transverse plane tangent to the foremost part of the lens of the headlamp.

6.1.6. Orientation

Towards the front.

Not more than one main-beam headlamp on each side of the vehicle may swivel to produce bend lighting.

6.1.7. Electrical connections

6.1.7.1. Except when they are used to give intermittent luminous warnings at short intervals, the main-beam headlamps may be switched ON only when the dipped-beam headlamps are manually activated or the conditions for automatic switching ON of dipped-beam headlamps exist. Consequently, the main beam headlamps shall be switched OFF automatically when the dipped-beam headlamps are manually deactivated or the conditions for automatic switching ON of dipped-beam headlamps ceased to exist.

6.1.7.2. The control of the main-beam headlamps may be automatic regarding their switching ON and OFF, the control signals being produced by a sensor system which is capable of detecting and reacting to each of the following inputs:

- (a) Ambient lighting conditions;
- (b) The light emitted by the front lighting devices and front light-signalling devices of oncoming vehicles;
- (c) The light emitted by the rear light-signalling devices of preceding vehicles.

Additional sensor functions to improve performance are allowed.

For the purpose of this paragraph, "vehicles" means vehicles of categories L, M, N, O, T, as well as bicycles, such vehicles being equipped with retro-reflectors, with lighting and light-signalling devices, which are switched ON.

6.1.7.3. It shall always be possible to switch the main-beam headlamps ON and OFF manually and to manually deactivate the automatic control of the main-beam headlamps.

Moreover, the switching OFF of the main-beam headlamps and the deactivation of their automatic control shall be by means of a simple and immediate manual operation; the use of sub-menus is not allowed.

6.1.7.4. The main-beam headlamps may be switched ON either simultaneously or in pairs. In case the extra two main-beam headlamps are installed, as permitted under paragraph 6.1.2. for vehicles of the category N₃ only, no more than two pairs may be simultaneously lit. For changing over from the dipped to the main beam at least one pair of main-beam headlamps shall be switched ON. For changing over from the main-beam to the dipped-beam all main-beam headlamps shall be switched OFF simultaneously.

6.1.7.5. The dipped-beams may remain switched ON at the same time as the main beams.

6.1.7.6. Where four concealable headlamps are fitted their raised position shall prevent the simultaneous operation of any additional headlamps fitted, if these are intended to provide light signals consisting of intermittent switching ON at short intervals (paragraph 5.12.) in daylight.

6.1.8. Tell-tale

Circuit-closed tell-tale mandatory.

6.1.8.1. If the control of the main-beam headlamps is automatic as described in paragraph 6.1.7.1. above an indication shall be provided to the driver that the automatic control of the main-beam function is activated. This information shall remain displayed as long as the automatic operation is activated.

6.1.9. Other requirements

6.1.9.1. The aggregate maximum intensity of the main-beam headlamps which can be switched ON simultaneously shall not exceed 430 000 cd, which corresponds to a reference value of 100.

6.1.9.2. This maximum intensity shall be obtained by adding together the individual reference marks which are indicated on the several headlamps. The reference mark "10" shall be given to each of the headlamps marked "R" or "CR".

6.1.9.3. Automatic switching ON and OFF of the main-beam headlamps:

6.1.9.3.1. The sensor system used to control the automatic switching ON and OFF of the main-beam headlamps, as described in paragraph 6.1.7.1., shall comply with the following requirements:

6.1.9.3.1.1. The boundaries of the minimum fields in which the sensor is able to detect light emitted from other vehicles defined in paragraph 6.1.7.1. above are defined by the angles indicated below.

6.1.9.3.1.1.1. Horizontal angles: 15° to the left and 15° to the right.

Vertical angles:

Upward angle	5°		
Mounting height of the sensor (centre of sensor aperture above the ground)	Less than 2 m	Between 1,5 m and 2,5 m	Greater than 2,0 m
Downward angle	2°	2° to 5°	5°

These angles are measured from the centre of the sensor aperture relative to a horizontal straight line through its centre and parallel to the longitudinal median plane of the vehicle.

6.1.9.3.1.2. The sensor system shall be able to detect on a straight level road:

- (a) An oncoming power driven vehicle at a distance extending to at least 400 m;
- (b) A preceding power driven vehicle or a vehicle-trailers combination at a distance extending to at least 100 m;
- (c) An oncoming bicycle at a distance extending to at least 75 m, its illumination represented by a white lamp with a luminous intensity of 150 cd with a light emitting area of 10 cm² ± 3 cm² and a height above a ground of 0,8 m.

To verify compliance with (a) and (b) above, the oncoming and preceding power driven vehicle (or vehicle-trailer combination) shall have position lamps (if applicable) and dipped-beam headlamps switched ON.

6.1.9.3.2. The transition from main-beam to dipped-beam and vice versa according to the conditions indicated in paragraph 6.1.7.1. above may be performed automatically and shall not cause discomfort, distraction or glare.

6.1.9.3.3. The overall performance of the automatic control shall be verified by:

6.1.9.3.3.1. Means of simulation or other means of verification accepted by the Type Approval Authority, as provided by the applicant.

6.1.9.3.3.2. A test drive according to paragraph 1 in Annex 12. The performance of the automatic control shall be documented and checked against the applicant's description. Any obvious malfunctioning shall be contested (e. g. excessive angular movement or flicker).

6.1.9.3.4. The control of the main-beam headlamps may be such that the main-beam headlamps are switched ON automatically only when:

(a) No vehicles, as mentioned in paragraph 6.1.7.1. above, are detected within the fields and distances according to paragraphs 6.1.9.3.1.1. and 6.1.9.3.1.2.; and

(b) The detected ambient lighting levels are as prescribed in paragraph 6.1.9.3.5. below.

6.1.9.3.5. In the case where main-beam headlamps are switched ON automatically, they shall be switched OFF automatically when oncoming or preceding vehicles, as mentioned in paragraph 6.1.7.1. above, are detected within the fields and distances according to paragraphs 6.1.9.3.1.1. and 6.1.9.3.1.2.

Moreover, they shall be switched OFF automatically when the illuminance produced by ambient lighting conditions exceeds 7 000 lx.

Compliance with with this requirement shall be demonstrated by the applicant, using simulation or other means of verification accepted by the Type Approval Authority. If necessary the illuminance shall be measured on a horizontal surface, with a cosine corrected sensor on the same height as the mounting position of the sensor on the vehicle. This may be demonstrated by the manufacturer by sufficient documentation or by other means accepted by the Type Approval Authority.

6.2. Dipped-beam headlamp (UN Regulations Nos. 98, 112 or 149)

6.2.1. Presence

Mandatory on motor vehicles. Prohibited on trailers.

6.2.2. Number

Two, type approved according to

(a) UN Regulation No. 98 or 112, excluding Class A headlamp,

or

(b) UN Regulation 149, Classes B and D headlamps only.

6.2.3. Arrangement

No special requirement.

6.2.4. Position

6.2.4.1. In width: that edge of the apparent surface in the direction of the reference axis which is farthest from the vehicle's median longitudinal plane shall be not more than 400 mm from the extreme outer edge of the vehicle.

The inner edges of the apparent surfaces in the direction of the reference axes shall be not less than 600 mm apart. This does not apply, however, for M₁ and N₁ category vehicles; for all other categories of motor vehicles this distance may be reduced to 400 mm where the overall width of the vehicle is less than 1 300 mm.

6.2.4.2. In height: not less than 500 mm and not more than 1 200 mm above the ground. For category N2G, N3G, M2G, M3G (off-road) vehicles ⁽¹⁰⁾ the maximum height may be increased to 1 500 mm.

6.2.4.3. In length: at the front of the vehicle. This requirement shall be deemed to be satisfied if the light emitted does not cause discomfort to the driver either directly, or indirectly through the devices for indirect vision and/or other reflecting surfaces of the vehicle.

6.2.5. Geometric visibility

Defined by angles α and β as specified in paragraph 2.10.7.:

α = 15° upwards and 10° downwards,

β = 45° outwards and 10° inwards.

The presence of partitions or other items of equipment near the headlamp shall not give rise to secondary effects causing discomfort to other road users .

6.2.6. Orientation

Towards the front

6.2.6.1. Vertical orientation

6.2.6.1.1. The initial downward inclination of the cut-off of the dipped-beam to be set in the unladen vehicle state with one person in the driver's seat shall be specified within an accuracy of 0,1 per cent by the manufacturer and indicated in a clearly legible and indelible manner on each vehicle close to either headlamp or the manufacturer's plate by the symbol shown in Annex 7.

The value of this indicated downward inclination shall be defined in accordance with paragraph 6.2.6.1.2.

6.2.6.1.2. Depending on the mounting height in metres (h) of the lower edge of the apparent surface in the direction of the reference axis of the dipped-beam headlamp, measured on the unladen vehicles, the vertical inclination of the cut-off of the dipped- beam shall, under all the static conditions of Annex 5, remain between the following limits and the initial aiming shall have the following values:

$h < 0,8$

Limits: between -0,5 per cent and -2,5 per cent

Initial aiming: between -1,0 per cent and -1,5 per cent

$0,8 < h < 1,0$

Limits: between -0,5 per cent and -2,5 per cent

Initial aiming: between -1,0 per cent and -1,5 per cent

Or, at the discretion of the manufacturer,

Limits: between -1,0 per cent and -3,0 per cent

Initial aiming: between -1,5 per cent and -2,0 per cent

The application for the vehicle type-approval shall, in this case, contain information as to which of the two alternatives is to be used,

⁽¹⁰⁾ As defined in the Consolidated Resolution on the Construction of Vehicles (R.E.3.), document ECE/TRANS/WP.29/78/Rev.6, para. 2 - www.unece.org/trans/main/wp29/wp29wgs/wp29gen/wp29resolutions.html

$h > 1,0$

Limits: between -1,0 per cent and -3,0 per cent

Initial aiming: between -1,5 per cent and -2,0 per cent

The above limits and the initial aiming values are summarized in the diagram below.

For category N₃G (off-road) vehicles where the headlamps exceed a height of 1 200 mm, the limits for the vertical inclination of the cut-off shall be between: -1,5 per cent and -3,5 per cent.

The initial aim shall be set between: -2 per cent and -2,5 per cent.

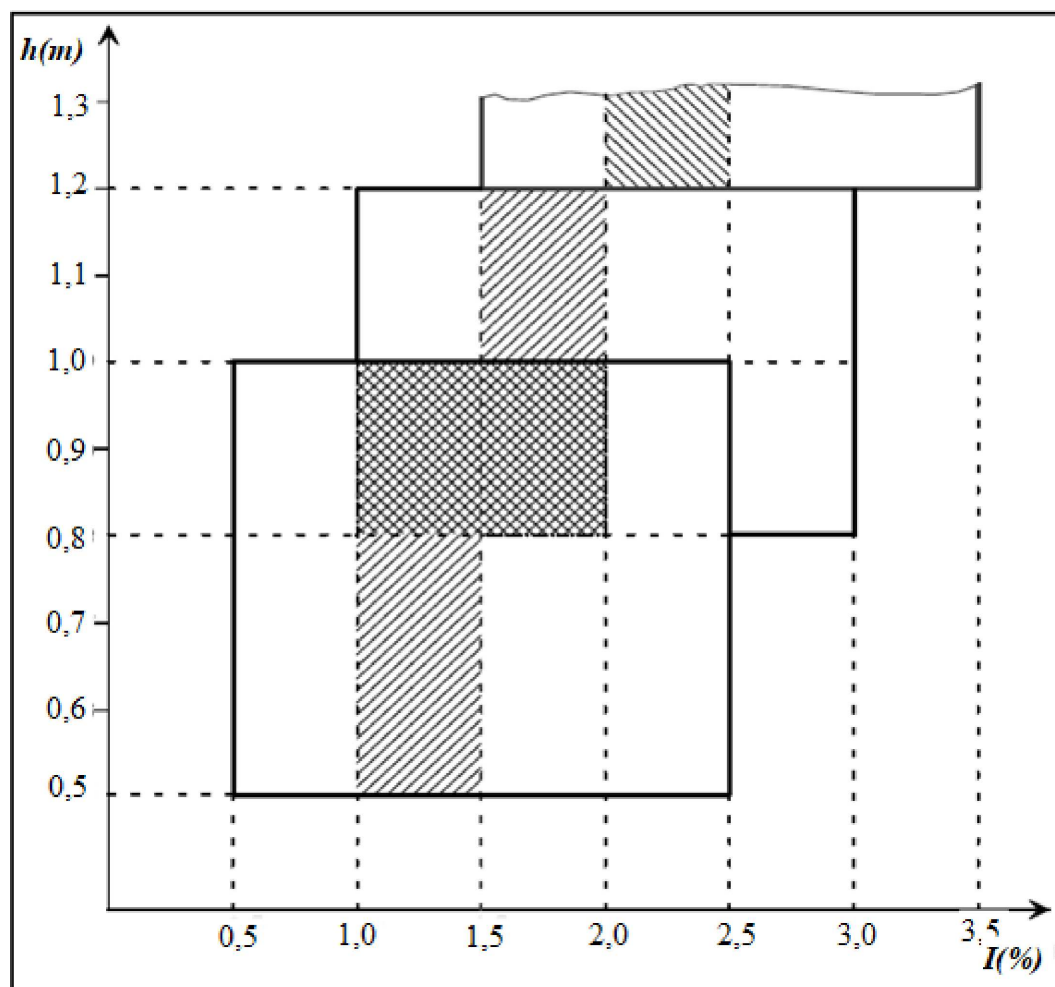

6.2.6.2. Headlamp levelling device

6.2.6.2.1. In the case where a headlamp levelling device is necessary to satisfy the requirements of paragraphs 6.2.6.1.1. and 6.2.6.1.2., the device shall be automatic.

6.2.6.2.2. However, devices which are adjusted manually, either continuously or non-continuously, shall be permitted, provided they have a stop position at which the lamps can be returned to the initial inclination defined in paragraph 6.2.6.1.1. by means of the usual adjusting screws or similar means.

These manually adjustable devices shall be operable from the driver's seat.

Continually adjustable devices shall have reference marks indicating the loading conditions that require adjustment of the dipped-beam.

The number of positions on devices which are not continuously adjustable shall be such as to ensure compliance with the range of values prescribed in paragraph 6.2.6.1.2. in all the loading conditions defined in Annex 5.

For these devices also, the loading conditions of Annex 5 that require adjustment of the dipped-beam shall be clearly marked near the control of the device (Annex 8).

6.2.6.2.3. In the event of a failure of devices described in paragraphs 6.2.6.2.1. and 6.2.6.2.2., the dipped-beam shall not assume a position in which the dip is less than it was at the time when the failure of the device occurred.

6.2.6.3. Measuring procedure

6.2.6.3.1. After adjustment of the initial inclination, the vertical inclination of the dipped-beam, expressed in per cent, shall be measured in static conditions under all the loading conditions defined in Annex 5.

6.2.6.3.2. The measurement of the variation of dipped-beam inclination as a function of load shall be carried out in accordance with the test procedure set out in Annex 6.

6.2.6.4. Horizontal orientation

The horizontal orientation of one or both dipped-beam headlamps may be varied to produce bend lighting, provided that if the whole beam or the kink of the elbow of the cut-off is moved, the kink of the elbow of the cut-off shall not intersect the line of the trajectory of the centre of gravity of the vehicle at distances from the front of the vehicle which are larger than 100 times the mounting height of the respective dipped-beam headlamps.

6.2.7. Electrical connections

6.2.7.1. When changing from the main beam to the dipped-beam, all main-beams shall be switched OFF simultaneously.

6.2.7.2. The dipped-beam may remain switched ON at the same time as the main-beam.

6.2.7.3. In the case of dipped-beam headlamps according to UN Regulation Nos. 98 or 149 the gas-discharge light sources shall remain switched ON during the main-beam operation.

6.2.7.4. One additional light source or one or more LED module(s), located inside the dipped-beam headlamps or in a lamp (except the main-beam headlamp) grouped or reciprocally incorporated with the respective dipped-beam headlamps, may be activated to produce bend lighting, provided that the horizontal radius of curvature of the trajectory of the centre of gravity of the vehicle is 500 m or less. This may be demonstrated by the manufacturer by calculation or by other means accepted by the Type Approval Authority.

6.2.7.5. Dipped-beam headlamps may be switched ON or OFF automatically. However, it shall be always possible to switch these dipped-beam headlamps ON and OFF manually.

6.2.7.6. The dipped-beam headlamps shall be switched ON and OFF automatically relative to the ambient light conditions (e.g. switch ON during night-time driving conditions, tunnels, etc.) according to the requirements of Annex 13.

6.2.7.7. Without prejudice to paragraph 6.2.7.6., the dipped-beam headlamps may switch ON and OFF automatically relative to other factors such as time or ambient conditions (e.g. time of the day, vehicle location, rain, fog, etc.)

6.2.8. Tell-tale

6.2.8.1. Tell-tale optional

6.2.8.2. A visual tell-tale whether flashing or not is mandatory:

- (a) In the case where the whole beam or the kink of the elbow of the cut-off is moved to produce bend lighting; or
- (b) If one or more LED modules are used to produce the principal dipped-beam, except when they are wired so that the failure of any one LED module causes all of them to stop emitting light.

It shall be activated:

- (a) In the event of a malfunction of the displacement of the kink of the elbow of the cut-off; or
- (b) In case of a failure of any one of the LED module(s) producing the principal dipped-beam, except when they are wired so that the failure of any one LED module causes all of them to stop emitting light.

It shall remain activated while the failure is present. It may be cancelled temporarily, but shall be repeated whenever the device, which starts and stops the propulsion system, is switched ON and OFF.

6.2.9. Other requirements

The requirements of paragraph 5.5.2. shall not apply to dipped-beam headlamps.

Dipped-beam headlamps with a light source or LED module(s) producing the principal dipped-beam and having a total objective luminous flux which exceeds 2 000 lumen shall only be installed in conjunction with the installation of headlamp cleaning device(s) according to UN Regulation No. 45 ⁽¹⁾.

With respect to vertical inclination the provisions of paragraph 6.2.6.2.2. above shall not be applied for dipped-beam headlamps with a light source or LED module(s) producing the principal dipped beam and having an objective luminous flux which exceeds 2 000 lumens.

In the case of filament lamps for which more than one test voltage is specified, the objective luminous flux which produces the principal dipped-beam, as indicated in the communication form for the type approval of the device, is applied.

In the case of dipped-beam headlamps equipped with an approved light source, the applicable objective luminous flux is the value at the relevant test voltage as given in the relevant data sheet in the Regulation, according to which the applied light source was approved, without taking into account the tolerances to the objective luminous flux specified on this datasheet.

Only dipped-beam headlamps according to UN Regulation Nos. 98, 112 or 149 may be used to produce bend lighting.

If bend lighting is produced by a horizontal movement of the whole beam or the kink of the elbow of the cut-off, it shall be switched ON only if the vehicle is in forward motion; this shall not apply if bend lighting is produced for a right turn in right hand traffic (left turn in left hand traffic).

6.3. Front fog lamp (UN Regulation No. 19 or 149)

6.3.1. Presence

Optional on motor vehicles. Prohibited on trailers.

⁽¹⁾ Contracting Parties to the respective UN Regulations can still prohibit the use of mechanical cleaning systems when headlamps with plastic lenses, marked "PL", are installed.

6.3.2. Number

Two, complying with either the requirements of the 03 and subsequent series of amendments to UN Regulation No. 19 or the requirements of UN Regulation No. 149.

6.3.3. Arrangement

No special requirement.

6.3.4. Position

6.3.4.1. In width: that point on the apparent surface in the direction of the reference axis which is farthest from the vehicle's median longitudinal plane shall not be more than 400 mm from the extreme outer edge of the vehicle.

6.3.4.2. In height:

Minimum: Not less than 250 mm above the ground.

Maximum: For M₁ and N₁ category vehicles: not more than 800 mm above the ground.

For all other categories except N₃G (off-road) ⁽¹²⁾ vehicles: not more than 1 200 mm above the ground.

For category N₃G vehicles: the maximum height may be increased to 1 500 mm.

No point on the apparent surface in the direction of the reference axis shall be higher than the highest point on the apparent surface in the direction of the reference axis of the dipped-beam headlamp.

6.3.4.3. In length: at the front of the vehicle. This requirement shall be deemed to be satisfied if the light emitted does not cause discomfort to the driver either directly, or indirectly through the devices for indirect vision and/or other reflecting surfaces of the vehicle.

6.3.5. Geometric visibility

Defined by angles α and β as specified in paragraph 2.10.7.:

α = 5° upwards and downwards,

β = 45° outwards and 10° inwards.

The presence of partitions or other items of equipment near the front fog lamp shall not give rise to secondary effects causing discomfort to other road users. ⁽¹³⁾

6.3.6. Orientation

Toward the front.

6.3.6.1. Vertical orientation

6.3.6.1.1. In the case of class "B" front fog lamps the vertical inclination of the cut-off to be set in the unladen vehicle state with one person in the driver's seat shall be -1.5 per cent or lower. ¹³

⁽¹²⁾ As defined in the Consolidated Resolution on the Construction of Vehicles (R.E.3.), document ECE/TRANS/WP.29/78/Rev.6, para. 2 - www.unece.org/trans/main/wp29/wp29wgs/wp29gen/wp29resolutions.html

⁽¹³⁾ New vehicle types which do not comply with this provision may continue to be approved until 18 months after the entry into force of Supplement 4 to the 03 series of amendments.

- 6.3.6.1.2. In the case of class "F3" front fog lamps:
- 6.3.6.1.2.1. When the total objective luminous flux of the light source for each front fog lamp does not exceed 2 000 lumens:
- 6.3.6.1.2.1.1. The vertical inclination of the cut-off to be set in the unladen vehicle state with one person in the driver's seat shall be – 1.0 per cent or lower
- 6.3.6.1.2.2. When the total objective luminous flux of the light source for each front fog lamp exceeds 2 000 lumens:
- 6.3.6.1.2.2.1. Depending on the mounting height in metres (h) of the lower edge of the apparent surface in the direction of the reference axis of the front fog lamp, measured on the unladen vehicles, the vertical inclination of the cut-off shall under all the static conditions of Annex 5 automatically remain between the following values:
- $h \leq 0,8$
- Limits: between -1,0 per cent and -3,0 per cent
Initial aiming: between -1,5 per cent and -2,0 per cent
- $h > 0,8$
- Limits: between -1,5 per cent and -3,5 per cent
Initial aiming: between -2,0 per cent and -2,5 per cent,
- 6.3.6.1.2.2.2. The initial downward inclination of the cut-off to be set in the unladen vehicle state with one person in the driver's seat shall be specified within an accuracy of one decimal place by the manufacturer and indicated in a clearly legible and indelible manner on each vehicle close to either the front fog lamp or the manufacturer's plate or in combination with the indication referred to in paragraph 6.2.6.1.1. by the symbol shown in Annex 7 to this Regulation. The value of this indicated downward inclination shall be defined in accordance with paragraph 6.3.6.1.2.2.1.
- 6.3.6.2. Front fog lamp levelling device
- 6.3.6.2.1. Where a levelling device is fitted for a front fog lamp, independent or grouped with other front lighting and light signalling functions, it shall be such that the vertical inclination, under all the static loading conditions of Annex 5 of this Regulation, shall remain between the limits prescribed in paragraph 6.3.6.1.2.2.1.
- 6.3.6.2.2. In the case where the front fog lamp of category "F3" is part of the dipped-beam headlamp or is part of an AFS system, the requirements of paragraph 6.2.6. shall be applied during the use of the front fog beam as part of the dipped-beam.
- In this case the levelling limits defined in paragraph 6.2.6. may be applied also when this front fog lamp is used as such.
- 6.3.6.2.3. The levelling device may also be used to automatically adapt the inclination of the front fog beam in relation to the prevailing ambient conditions, provided that the limits for the downward inclination specified in paragraph 6.3.6.1.2.2.1. are not exceeded.
- 6.3.6.2.4. In the case of a failure of the levelling device, the front fog beam shall not assume a position in which the cut off is less inclined than it was at the time when the failure of the device occurred.

6.3.7. Electrical connections

It shall be possible to switch the front fog lamps ON and OFF independently of the main-beam headlamps, the dipped-beam headlamps or any combination of main- and dipped-beam headlamps, unless:

- (a) The front fog lamps are used as part of another lighting function in an AFS; however, the switching ON of the front fog lamps function shall have the priority over the function for which the front fog lamps are used as a part, or
- (b) The front fog lamps cannot be simultaneously lit with any other lamps with which they are reciprocally incorporated as indicated by the relevant symbol ("") according to paragraph 10.1. of Annex 1 of UN Regulation No. 19. or item 9.5.1. of Annex 1 of UN Regulation No. 149.

6.3.8. Tell-tale

Circuit-closed tell-tale mandatory. An independent non-flashing warning light.

6.3.9. Other requirements

In the case where there is a positive indication in the communication form in Annex 1 of UN Regulation No. 19 or in Annex 1 of UN Regulation No. 149 the alignment and the luminous intensities of the Class "F3" front fog beam may be automatically adapted in relation to the prevailing ambient conditions. Any variations of the luminous intensities or alignment shall be performed automatically and in such a way that no discomfort, neither for the driver nor to other road users, is caused.

6.4. Reversing lamp (UN Regulation No. 23 or 148))

6.4.1. Presence

Mandatory on motor vehicles and on trailers of categories O₂, O₃ and O₄. Optional on trailers of category O₁.

6.4.2. Number

6.4.2.1. One device mandatory and a second device optional on motor vehicles of category M₁ and on all other vehicles with a length not exceeding 6 000 mm.

6.4.2.2. Two devices mandatory and two devices optional on all vehicles with a length exceeding 6 000 mm, except vehicles of category M₁.

6.4.3. Arrangement

No special requirement.

6.4.4. Position

6.4.4.1. In width: no special requirement.

6.4.4.2. In height: not less than 250 mm and not more than 1 200 mm above the ground. For category N2G, N3G, M2G, M3G (off-road) vehicles the maximum height may be increased to 1 400 mm.

6.4.4.3. In length: at the rear of the vehicle

However, if installed, the two optional devices mentioned in paragraph 6.4.2.2. may be fitted on the side of the vehicle, provided that the requirements of paragraphs 6.4.5.2. and 6.4.6.2. below are fulfilled.

6.4.5. Geometric visibility

6.4.5.1. Devices installed at the rear of the vehicle:

Defined by angles α and β , as specified in paragraph 2.10.7.:

$\alpha = 15^\circ$ upwards and 5° downwards,

$\beta = 45^\circ$ to right and to left if there is only one device,

45° outwards and 30° inwards if there are two.

6.4.5.2. Two optional devices mentioned in paragraph 6.4.2.2. if fitted on the side of the vehicle:

The geometric visibility is considered to be ensured if the reference axis of the respective device is directed outwards with an angle β not exceeding 15° relative to the median longitudinal plane of the vehicle. The vertical aim of the two optional devices may be directed downwards.

6.4.6. Orientation

6.4.6.1. Rearwards

6.4.6.2. In addition, if the two optional devices mentioned in paragraph 6.4.2.2., are fitted on the side of the vehicle, the provisions of paragraph 6.4.5.2. above shall apply.

6.4.7. Electrical connections

6.4.7.1. They shall be such that the lamp can be switched ON only if the reverse gear is engaged and if the device which controls the starting and stopping of the propulsion system is in such a position that operation of the propulsion system is possible. It shall not switch ON or remain ON if either of the above conditions is not satisfied.

6.4.7.2. Moreover, the electrical connections of the two optional devices mentioned in paragraph 6.4.2.2. shall be such that these devices cannot be switched ON unless the lamps referred to in paragraph 5.11. are switched ON.

The devices fitted on the side of the vehicle may be switched ON for slow manoeuvres in forward motion of the vehicle up to a maximum speed of 15 km/h, provided that the following conditions are fulfilled:

- (a) The devices shall be switched ON and OFF manually by a separate control;
- (b) If so switched ON, they may remain ON after reverse gear is disengaged;
- (c) They shall be automatically switched OFF if the forward speed of the vehicle exceeds 15 km/h, regardless of the position of the separate control; in this case they shall remain switched OFF until deliberately being switched ON again.

6.4.8. Tell-tale

Tell-tale optional.

6.4.9. Other requirements

None.

6.5. Direction-indicator lamp (UN Regulation No. 6 or 148)

6.5.1. Presence (see figure below)

Mandatory. Types of direction-indicator lamps fall into categories (1, 1a, 1b, 2a, 2b, 5 and 6) the assembly of which on one vehicle constitutes an arrangement ("A" and "B").

Arrangement "A" shall apply to all motor vehicles.

Arrangement "B" shall apply to trailers only.

6.5.2. Number

According to the arrangement.

6.5.3. Arrangements (see figure below)

A: Two front direction-indicator lamps of the following categories:

1 or 1a or 1b,

If the distance between the edge of the apparent surface in the direction of the reference axis of this lamp and that of the apparent surface in the direction of the reference axis of the dipped-beam headlamp and/or the front fog lamp, if there is one, is at least 40 mm;

1a or 1b,

If the distance between the edge of the apparent surface in the direction of the reference axis of this lamp and that of the apparent surface in the direction of the reference axis of the dipped-beam headlamp and/or the front fog lamp, if there is one, is greater than 20 mm and less than 40 mm;

1b,

If the distance between the edge of the apparent surface in the direction of the reference axis of this lamp and that of the apparent surface in the direction of the reference axis of the dipped-beam headlamp and/or the front fog lamp, if there is one, is less than or equal to 20 mm;

Two rear direction-indicator lamps (category 2a or 2b);

Two optional lamps (category 2a or 2b) on all vehicles in categories M₂, M₃, N₂, N₃.

Two side direction-indicator lamps of the categories 5 or 6 (minimum requirements):

5

For all M₁ vehicles;

For N₁, M₂ and M₃ vehicles not exceeding 6 metres in length.

6

For all N₂ and N₃ vehicles;

For N₁, M₂ and M₃ vehicles exceeding 6 metres in length.

It is permitted to replace category 5 side direction-indicator lamps by category 6 side direction-indicator lamps in all instances

Where lamps combining the functions of front direction-indicator lamps (categories 1, 1a, 1b) and side direction-indicator lamps (categories 5 or 6) are fitted, two additional side direction-indicator lamps (categories 5 or 6) may be fitted to meet the visibility requirements of paragraph 6.5.5.

B: two rear direction-indicator lamps (Categories 2a or 2b)

Two optional lamps (category 2a or 2b) on all vehicles in categories O₂, O₃ and O₄.

A maximum of three optional category 5 or one optional category 6 device per side on vehicles of category O₂ exceeding 9 m in length.

Where an AFS is fitted, the distance to be considered for the choice of the category is the distance between the front direction-indicator lamp and the closest lighting unit in its closest position contributing to or performing a passing-beam mode.

6.5.3.1. In addition, for vehicles of categories:

(a) M₂, M₃, N₂, and N₃ of above 6 m and up to including 9 m in length one additional category 5 device is optional;

(b) M₂, M₃, N₂, and N₃ exceeding 9 m in length three additional category 5 devices distributed as evenly as practicable along each side are mandatory;

(c) O₃ and O₄ three category 5 devices distributed as evenly as practicable along each side are mandatory.

These requirements do not apply if there are at least three amber side marker lamps that flash in phase and simultaneously with the direction indicator lamps on the same side of the vehicle.

6.5.4. Position

6.5.4.1. In width: the edge of the apparent surface in the direction of the reference axis farthest from the median longitudinal plane of the vehicle shall not be more than 400 mm from the extreme outer edge of the vehicle. This condition shall not apply to the optional rear lamps.

The distance between the inner edges of the two apparent surfaces in the direction of the reference axes shall not be less than 600 mm.

This distance may be reduced to 400 mm where the overall width of the vehicle is less than 1 300 mm.

6.5.4.2. In height: above the ground.

6.5.4.2.1. The height of the light-emitting surface of the side direction-indicator lamps of categories 5 or 6 shall not be:

Less than: 350 mm for M₁ and N₁ category of vehicles, and 500 mm for all other categories of vehicles, both measured from the lowest point; and

More than: 1 500 mm, measured from the highest point.

6.5.4.2.2. The height of the direction-indicator lamps of categories 1, 1a, 1b, 2a and 2b, measured in accordance with paragraph 5.8., shall not be less than 350 mm and not more than 1 500 mm.

6.5.4.2.3. If the structure of the vehicle does not permit these upper limits, measured as specified above, to be respected, and if the optional rear lamps are not installed, they may be increased to 2 300 mm for side direction-indicator lamps of categories 5 and 6, and to 2 100 mm for the direction-indicator lamps of categories 1, 1a, 1b, 2a and 2b.

6.5.4.2.4. If optional rear lamps are installed, they shall be placed at a height compatible with the applicable requirements of paragraph 6.5.4.1., the symmetry of the lamps, and at a vertical distance as large as the shape of the bodywork makes it possible, but not less than 600 mm above the mandatory lamps.

6.5.4.3. In length (see figure below)

The distance between the light-emitting surface of the side direction-indicator lamp (categories 5 and 6) and the transverse plane which marks the forward boundary of the vehicle's overall length, shall not exceed 1 800 mm.

However, this distance shall not exceed 2 500 mm:

(a) For M₁ and N₁ category vehicles;

(b) For all other categories of vehicles if the structure of the vehicle makes it impossible to comply with the minimum angles of visibility.

Optional category 5 side direction indicator lamps, shall be fitted, spaced evenly, along the length of the vehicle.

Optional category 6 side direction indicator lamp shall be fitted in the area between the first and last quartiles of the length of a trailer.

6.5.5. Geometric visibility

6.5.5.1. Horizontal angles: (see figure below)

Vertical angles: 15° above and below the horizontal for direction indicator lamps of categories 1, 1a, 1b, 2a, 2b and 5.

However:

- (a) Where a lamp is mounted below 750 mm (measured according to the provisions of paragraph 5.8.1), the downward angle of 15° may be reduced to 5°;
- (b) Where an optional rear lamp is mounted above 2 100 mm (measured according to the provisions of paragraph 5.8.1. above) the upward angle of 15° may be reduced to 5°.

30° above and 5° below the horizontal for direction indicator lamps of category 6.

Figure (see paragraph 6.5.)

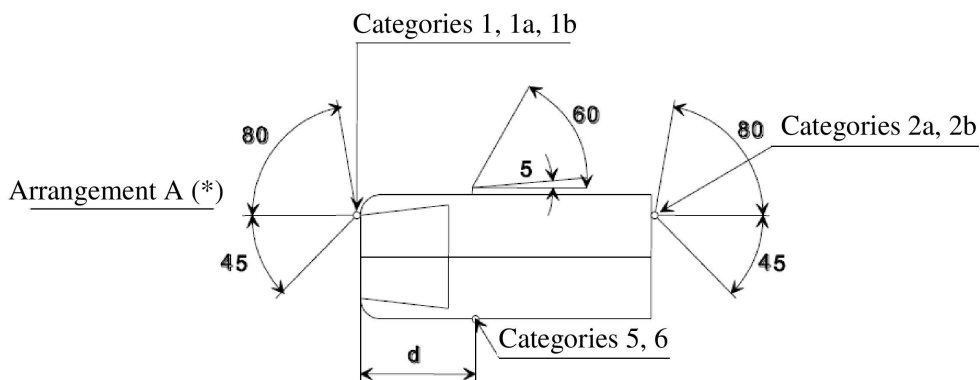

(*) The value of 5° given for dead angle of visibility to the rear of the side direction-indicator is an upper limit $d \leq 1.80$ m (for M_1 and N_1 category vehicles $d \leq 2.50$ m).

For the direction indicator lamps of categories 1, 1a, 1b, 2a and 2b mounted below 750 mm (measured according to the provisions of paragraph 5.8.1), the inward angle of 45° may be reduced to 20° under the H plane.

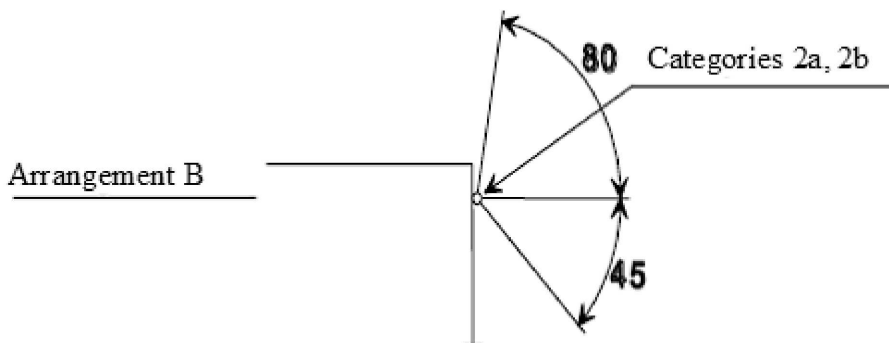

6.5.5.2. Or, at the discretion of the manufacturer, for M_1 and N_1 category vehicles: Front and rear direction indicator lamps, as well as side-marker lamps (**).

Horizontal angles: (see figure below)

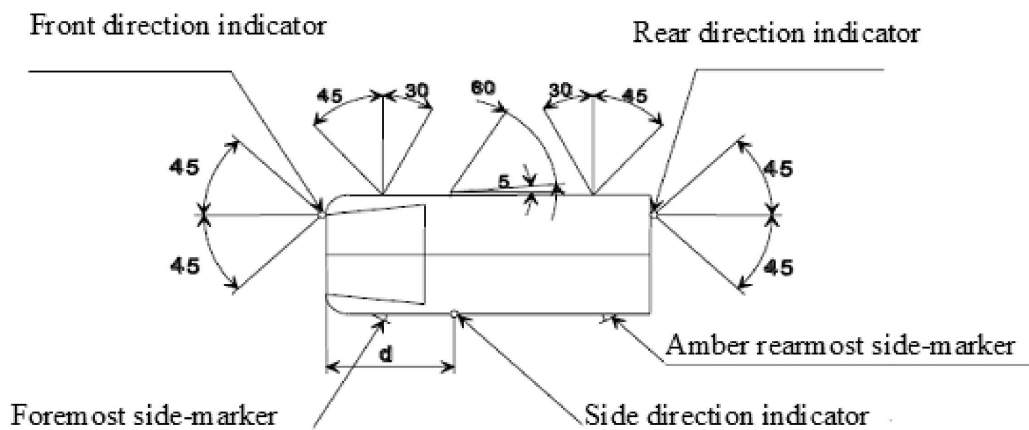

(**) The value of 5° given for the dead angle of visibility to the rear of the side direction-indicator is an upper limit. $d \leq 2.50$ m

However, for the direction indicator lamps of categories 1, 1a, 1b, 2a and 2b mounted below 750 mm (measured according to the provisions of paragraph 5.8.1. above), the inward angle of 45° may be reduced to 20° under the H plane.

Vertical angles: 15° above and below the horizontal. However, where a lamp is mounted below 750 mm (measured according to the provisions of paragraph 5.8.1), the downward angle of 15° may be reduced to 5°.

To be considered visible, the lamp shall provide an unobstructed view of the apparent surface of at least 12.5 square centimetres, except for side direction-indicators of categories 5 and 6. The illuminating surface area of any retro-reflector that does not transmit light shall be excluded.

6.5.6. Orientation

According to the specifications for installation by the manufacturer, if any.

6.5.7. Electrical connections

Direction-indicator lamps shall switch ON independently of the other lamps. All direction-indicator lamps on one side of a vehicle shall be switched ON and OFF by means of one control and shall flash in phase.

On M_1 and N_1 vehicles less than 6 m in length, with an arrangement complying with paragraph 6.5.5.2. above, the amber side-marker lamps, when mounted, shall also flash at the same frequency (in phase) with the direction-indicator lamps.

6.5.8. Tell-tale

Operating tell-tale mandatory for direction-indicator lamps of categories 1, 1a, 1b, 2a and 2b. It may be visual or auditory or both. If it is visual it shall be a flashing light which, at least in the event of the malfunction of any of these direction-indicator lamps, is either extinguished, or remains alight without flashing, or shows a marked change of frequency. If it is entirely auditory it shall be clearly audible and shall show a marked change of frequency, at least in the event of the malfunction of any of these direction-indicator lamps.

It shall be activated by the signal produced according to paragraph 6.2.2. of UN Regulation No. 6 or according to paragraph 5.6.3. of UN Regulation No. 148 or another suitable way¹³.

If a motor vehicle is equipped to draw a trailer, it shall be fitted with a special visual operational tell-tale for the direction-indicator lamps on the trailer unless the tell-tale of the drawing vehicle allows the failure of any one of the direction-indicator lamps on the vehicle combination thus formed to be detected.

For the optional direction-indicator lamps on motor vehicles and trailers, operating tell-tale shall not be mandatory.

6.5.9. Other requirements

The light shall be a flashing light flashing 90 ± 30 times per minute.

Operation of the light-signal control shall be followed within not more than one second by the emission of light and within not more than one and one-half seconds by its first extinction. If a motor vehicle is equipped to draw a trailer, the control of the direction-indicator lamps on the drawing vehicle shall also operate the indicator lamps of the trailer. In the event of failure, other than short-circuit, of one direction-indicator lamp, the others shall continue to flash, but the frequency in this condition may be different from that prescribed.

6.6. Hazard warning signal

6.6.1. Presence

Mandatory.

The signal shall be given by simultaneous operation of the direction-indicator lamps in accordance with the requirements of paragraph 6.5. above.

All direction indicators of the category 1 (1, 1a, 1b) activated simultaneously shall operate in the same mode; i.e. static or sequential.

All direction indicators of the category 2 (2a, 2b) activated simultaneously shall operate in the same mode; i.e. static or sequential.

6.6.2. Number

As specified in paragraph 6.5.2.

6.6.3. Arrangement

As specified in paragraph 6.5.3.

6.6.4. Position

6.6.4.1. Width: As specified in paragraph 6.5.4.1.

6.6.4.2. Height: As specified in paragraph 6.5.4.2.

6.6.4.3. Length: As specified in paragraph 6.5.4.3.

6.6.5. Geometric visibility

As specified in paragraph 6.5.5.

6.6.6. Orientation

As specified in paragraph 6.5.6.

6.6.7. Electrical connections

6.6.7.1. The signal shall be operated by means of a separate manual control enabling all the direction-indicator lamps to flash in phase.

6.6.7.2. The hazard warning signal may be switched ON automatically in the event of a vehicle being involved in a collision or after the emergency stop signal has been switched OFF, as specified in paragraph 6.23. below. In such cases, it may be switched OFF manually.

In addition, the hazard warning signal may be switched ON automatically to indicate to other road-users the risk of imminent danger as defined by Regulations; in this case, the signal shall remain switched ON until it is manually or automatically switched OFF.

6.6.7.3. On M_1 and N_1 vehicles less than 6 m in length, with an arrangement complying with paragraph 6.5.5.2. above, the amber side-marker lamps, when mounted, shall also flash at the same frequency (in phase) with the direction-indicator lamps.

6.6.8. Tell-tale

Flashing circuit-closed tell-tale mandatory.

6.6.9. Other requirements

As specified in paragraph 6.5.9., if a power-driven vehicle is equipped to draw a trailer, the hazard warning signal control shall also be capable of bringing the direction-indicator lamps on the trailer into action. The hazard warning signal shall be able to function even if the device which starts or stops the propulsion system is in a position which makes it impossible to start the propulsion system.

6.7. Stop lamp (UN Regulation No.7 or 148)

6.7.1. Presence

Devices of S1 or S2 categories: mandatory on all categories of vehicles.

Devices of S3 or S4 category: mandatory on M_1 and N_1 categories of vehicles, except for chassis-cabs and those N_1 category vehicles with open cargo space; optional on other categories of vehicles.

6.7.2. Number

Two S1 or S2 category devices and one S3 or S4 category device on all categories of vehicles.

6.7.2.1. Except in the case where a category S3 or S4 device is installed, two optional category S1 or S2 devices may be installed on vehicles in categories M_2 , M_3 , N_2 , N_3 , O_2 , O_3 , and O_4 .

6.7.2.2. Only, when the median longitudinal plane of the vehicle is not located on a fixed body panel but separates one or two movable parts of the vehicle (e.g. doors), and lacks sufficient space to install a single device of the S3 or S4 category on the median longitudinal plane above such movable parts, either:

Two devices of the S3 or S4 category type "D" may be installed; or

One device of the S3 or S4 category may be installed offset to the left or to the right of the median longitudinal plane, or

An interdependent lamp system of category S3 or S4 may be installed.

6.7.3. Arrangement

No special requirement.

6.7.4. Position

6.7.4.1. In width:

For M_1 and N_1 category vehicles:

For S1 or S2 categories devices that point on the apparent surface in the direction of the reference axis which is farthest from the vehicle's median longitudinal plane shall not be more than 400 mm from the extreme outer edge of the vehicle;

For the distance in between the inner edges of the apparent surfaces in the direction of the reference axes there is no special requirement.

For all other categories of vehicles:

For S1 or S2 categories devices the distance in between the inner edges of the apparent surfaces in the direction of the reference axes shall be not less than 600 mm. This distance may be reduced to 400 mm if the overall width of the vehicle is less than 1 300 mm.

For S3 or S4 category devices: the centre of reference shall be situated on the median longitudinal plane of the vehicle. However, in the case where the two devices of the S3 or S4 category are installed, according to paragraph 6.7.2., they shall be positioned as close as possible to the median longitudinal plane, one on each side of this plane.

In the case where one S3 or S4 category lamp offset from the median longitudinal plane is permitted according to paragraph 6.7.2., this offset shall not exceed 150 mm from the median longitudinal plane to the centre of reference of the lamp.

6.7.4.2. In height:

6.7.4.2.1. For S1 or S2 categories devices:

Above the ground, not less than 350 mm nor more than 1 500 mm (2 100 mm if the shape of the bodywork makes it impossible to keep within 1 500 mm and if the optional lamps are not installed).

If the optional lamps are installed, they shall be positioned at a height compatible with the requirements of the width and the symmetry of the lamps, and at a vertical distance as large as the shape of the bodywork makes it possible, but not less than 600 mm above the mandatory lamps.

6.7.4.2.2. For S3 or S4 categories devices:

The horizontal plane tangential to the lower edge of the apparent surface shall: either not be more than 150 mm below the horizontal plane tangential to the lower edge of the exposed surface of the glass or glazing of the rear window, or not be less than 850 mm above the ground.

However, the horizontal plane tangential to the lower edge of the apparent surface of a S3 or S4 category device shall be above the horizontal plane tangential to the upper edge of the apparent surface of S1 or S2 categories devices.

6.7.4.3. In length:

6.7.4.4. For S1 or S2 categories devices: at the rear of the vehicle.

6.7.4.5. For S3 or S4 categories devices: no special requirement.

6.7.5. Geometric visibility

Horizontal angle:

For S1 or S2 categories devices: 45° to the left and to the right of the longitudinal axis of the vehicle.

However, for the stop lamps of categories S1 and S2 mounted below 750 mm (measured according to the provisions of paragraph 5.8.1. above), the inward angle of 45° may be reduced to 20° under the H plane.

For S3 or S4 categories devices: 10° to the left and to the right of the longitudinal axis of the vehicle;

Vertical angle:

For S1 or S2 categories devices: 15° above and below the horizontal.

However,

- (a) Where a lamp is mounted below 750 mm (measured according to the provisions of paragraph 5.8.1. above), the downward angle of 15° may be reduced to 5°;
- (b) Where an optional lamp is mounted above 2 100 mm (measured according to the provisions of paragraph 5.8.1. above) the upward angle of 15° may be reduced to 5°.

For S3 or S4 categories devices: 10° above and 5° below the horizontal.

6.7.6. Orientation

Towards the rear of the vehicle.

6.7.7. Electrical connections

6.7.7.1. All stop lamps shall be switched ON simultaneously when the braking system provides the relevant signal defined in UN Regulations Nos. 13 and 13-H.

6.7.7.2. The stop lamps need not function if the device, which starts and/or stops the propulsion system, is in a position that makes it impossible for the propulsion system to operate.

6.7.8. Tell-tale

Tell-tale optional, however, a tell-tale indicating failure is mandatory if required by the component regulation.

Where the above tell-tale is fitted, this tell-tale shall be an operating tell-tale consisting of a non-flashing warning light which comes on in the event of the malfunctioning of the stop lamps.

6.7.9. Other requirements

6.7.9.1. The S3 or S4 category device may not be reciprocally incorporated with any other lamp.

6.7.9.2. The S3 or S4 category device may be installed outside or inside the vehicle.

6.7.9.2.1. In the case where it is installed inside the vehicle:

The light emitted shall not cause discomfort to the driver through the devices for indirect vision and/or other surfaces of the vehicle (i.e. rear window).

6.8. Rear registration plate lamp (UN Regulation No. 4 or 148)

6.8.1. Presence

Mandatory.

6.8.2. Number

Such that the device illuminates the site of the registration plate according to the type-approval documentation of the device.

6.8.3. Arrangement

Such that the device illuminates the site of the registration plate according to the type-approval documentation of the device.

6.8.4. Position

6.8.4.1. In width: Such that the device illuminates the site of the registration plate according to type-approval documentation of the device.

- 6.8.4.2. In height: Such that the device illuminates the site of the registration plate according to the type-approval documentation of the device.
- 6.8.4.3. In length: Such that the device illuminates the site of the registration plate according to the type-approval documentation of the device.
- 6.8.5. Geometric visibility
Such that the device illuminates the site of the registration plate according to the type-approval documentation of the device.
- 6.8.6. Orientation
Such that the device illuminates the site of the registration plate according to the type-approval documentation of the device.
- 6.8.7. Electrical connections
In accordance with paragraph 5.11.
- 6.8.8. Tell-tale
Tell-tale optional. If it exists, its function shall be carried out by the tell-tale required for the front and rear position lamps.
- 6.8.9. Other requirements
When the rear registration plate lamp is combined with the rear position lamp, reciprocally incorporated in the stop lamp or in the rear fog lamp, the photometric characteristics of the rear registration plate lamp may be modified during the entire time the stop lamp or the rear fog lamp is switched ON.
- 6.9. Front position lamp (UN Regulation No. 7 or 148)
- 6.9.1. Presence
Mandatory on all motor vehicles.
Mandatory on trailers over 1 600 mm wide.
Optional on trailers which are not more than 1 600 mm wide.
- 6.9.2. Number
Two.
- 6.9.3. Arrangement
No special requirement.
- 6.9.4. Position
- 6.9.4.1. In width: that point on the apparent surface in the direction of the reference axis which is farthest from the vehicle's median longitudinal plane shall not be more than 400 mm from the extreme outer edge of the vehicle.

In the case of a trailer, that point on the apparent surface in the direction of the reference axis which is farthest from the median longitudinal plane shall not be more than 150 mm from the extreme outer edge of the vehicle.

The distance between the inner edges of the two apparent surfaces in the direction of the reference axes shall:

For M₁ and N₁ category vehicles: No special requirement;

For all other categories of vehicles: Not less than 600 mm. This distance may be reduced to 400 mm where the overall width of the vehicle is less than 1 300 mm.

- 6.9.4.2. In height: above the ground, not less than 250 mm nor more than 1 500 mm (2 100 mm for O₁ and O₂ categories of vehicles, or if for any other categories of vehicles the shape of the bodywork makes it impossible to keep within 1 500 mm).
- 6.9.4.3. In length: no individual specification.
- 6.9.4.4. Where the front position lamp and another lamp are reciprocally incorporated, the apparent surface in the direction of the reference axis of the other lamp shall be used to verify compliance with the positioning requirements (paragraphs 6.9.4.1. to 6.9.4.3.).
- 6.9.5. Geometric visibility
- 6.9.5.1. Horizontal angle: 45° inwards and 80° outwards.
- However, where a lamp is mounted below 750 mm (measured according to the provisions of paragraph 5.8.1. above), the inward angle of 45° may be reduced to 20° under the H plane.
- In the case of trailers, the angle inwards may be reduced to 5°.
- Vertical angle: 15° above and below the horizontal. However, where a lamp is mounted below 750 mm (measured according to the provisions of paragraph 5.8.1. above), the downward angle of 15° may be reduced to 5°.
- 6.9.5.2. For M₁ and N₁ category vehicles, as an alternative to paragraph 6.9.5.1. above, at the discretion of the manufacturer or his duly accredited representative, and only if a front side-marker lamp is installed on the vehicle:
- Horizontal angle: 45° outwards to 45° inwards.
- However, where a lamp is mounted below 750 mm (measured according to the provisions of paragraph 5.8.1. above), the inward angle of 45° may be reduced to 20° under the H plane.
- Vertical angle: 15° above and below the horizontal.
- However, where a lamp is mounted below 750 mm (measured according to the provisions of paragraph 5.8.1. above), the downward angle of 15° may be reduced to 5°.
- To be considered visible, the lamp shall provide an unobstructed view of the apparent surface of at least 12.5 cm². The illuminating surface area of any retro-reflector that does not transmit light shall be excluded.
- 6.9.6. Orientation
- Forwards.
- 6.9.7. Electrical connections
- In accordance with paragraph 5.11.
- However, if a front position lamp is reciprocally incorporated with a direction-indicator the electrical connection of the front position lamp on the relevant side of the vehicle or the reciprocally incorporated part of it may be such that it is switched OFF during the entire time (both ON and OFF cycle) of operation of the direction-indicator lamp.
- 6.9.8. Tell-tale
- Circuit-closed tell-tale mandatory.
- This tell-tale shall be non-flashing and shall not be required if the instrument panel lighting can only switch ON simultaneously with the front position lamps.
- This requirement does not apply when light signalling system operates according to paragraph 6.19.7.4.
- However, a tell-tale indicating failure is mandatory if required by the component regulation.

- 6.9.9. Other requirements
- 6.9.9.1. If one or more infrared radiation generator(s) is (are) installed inside the front position lamp, it (they) is (are) allowed to be switched ON only when the headlamp on the same side of the vehicle is switched ON and the vehicle is in forward motion. In the event that the front position lamp or the headlamp on the same side fails, the infrared radiation generator(s) shall be automatically switched OFF.
- 6.9.9.2. In case an AFS providing a bending mode is installed, the front position lamp may be swivelled together with a lighting unit to which it is reciprocally incorporated.
- 6.10. Rear position lamp (UN Regulation No. 7 or 148)
- 6.10.1. Presence
Devices of R or R1 or R2 categories: Mandatory
- 6.10.2. Number
Two.
- 6.10.2.1. Except the case where end-outline marker lamps are installed, two optional position lamps may be installed on all vehicles in categories M₂, M₃, N₂, N₃, O₂, O₃, and O₄.
- 6.10.3. Arrangement
No special requirement.
- 6.10.4. Position
- 6.10.4.1. In width: that point on the apparent surface in the direction of the reference axis which is farthest from the vehicle's median longitudinal plane shall not be more than 400 mm from the extreme outer edge of the vehicle. This condition shall not apply to the optional rear lamps.
The distance between the inner edges of the two apparent surfaces in the direction of the reference axes shall:
For M₁ and N₁ category vehicles: have no special requirement;
For all other categories of vehicles: be not less than 600 mm. This distance may be reduced to 400 mm where the overall width of the vehicle is less than 1 300 mm.
- 6.10.4.2. In height: above the ground, not less than 350 mm nor more than 1 500 mm (2 100 mm if the shape of the bodywork makes it impossible to keep within 1 500 mm and if the optional lamps are not installed). If the optional lamps are installed, they shall be placed at a height compatible with the applicable requirements of paragraph 6.10.4.1., the symmetry of the lamps, and at a vertical distance as large as the shape of the bodywork makes it possible, but not less than 600 mm above the mandatory lamps.
- 6.10.4.3. In length: The rear of the vehicle.
- 6.10.5. Geometric visibility
- 6.10.5.1. Horizontal angle: 45° inwards and 80° outwards.
However, where a lamp is mounted below 750 mm (measured according to the provisions of paragraph 5.8.1. above), the inward angle of 45° may be reduced to 20° under the H plane.
Vertical angle: 15° above and below the horizontal.

However,

- (a) Where a lamp is mounted below 750 mm (measured according to the provisions of paragraph 5.8.1. above), the downward angle of 15° may be reduced to 5°;
- (b) Where an optional lamp is mounted above 2 100 mm (measured according to the provisions of paragraph 5.8.1. above) the upward angle of 15° may be reduced to 5°.

6.10.5.2. For M₁ and N₁ category vehicles, as an alternative to paragraph 6.10.5.1. above, at the discretion of the manufacturer or his duly accredited representative, and only if a rear side-marker lamp is installed on the vehicle,

Horizontal angle: 45° outwards to 45° inwards. However, where a lamp is mounted below 750 mm (measured according to the provisions of paragraph 5.8.1. above), the inward angle of 45° may be reduced to 20° under the H plane.

Vertical angle: 15° above and below the horizontal.

However, where a lamp is mounted below 750 mm (measured according to the provisions of paragraph 5.8.1. above), the downward angle of 15° may be reduced to 5°.

To be considered visible, the lamp shall provide an unobstructed view of the apparent surface of at least 12.5 square centimetres. The illuminating surface area of any retro-reflector that does not transmit light shall be excluded.

6.10.6. Orientation

Rearwards.

6.10.7. Electrical connections

In accordance with paragraph 5.11.

However, if a rear position lamp is reciprocally incorporated with a direction-indicator, the electrical connection of the rear position lamp on the relevant side of the vehicle or the reciprocally incorporated part of it may be such that it is switched OFF during the entire time (both ON and OFF cycle) of operation of the direction-indicator lamp.

6.10.8. Tell-tale

Circuit-closed tell-tale mandatory. It shall be combined with that of the front position lamps.

This requirement does not apply when light-signalling system operates according to paragraph 6.19.7.4.

However, a tell-tale indicating failure is mandatory if required by the component regulation.

6.10.9. Other requirements

None.

6.11. Rear fog lamp (UN Regulation No. 38 or 148)

6.11.1. Presence

Devices of F or F1 or F2 categories: Mandatory.

6.11.2. Number

One or two.

6.11.3. Arrangement

No special requirement.

- 6.11.4. Position
- 6.11.4.1. In width: if there is only one rear fog-lamp, it shall be on the opposite side of the median longitudinal plane of the vehicle to the direction of traffic prescribed in the country of registration, the centre of reference may also be situated on the median longitudinal plane of the vehicle.
- 6.11.4.2. In height: not less than 250 mm nor more than 1 000 mm above the ground. For rear fog lamps grouped with any rear lamp the maximum height may be increased to 1 200 mm. For categories N₂G, N₃G, M₂G, M₃G (off-road) vehicles the maximum height may be increased to 1 400 mm.
- 6.11.4.3. In length: at the rear of the vehicle.
- 6.11.5. Geometric visibility
Defined by angles α and β as specified in paragraph 2.10.7.:
 $\alpha = 5^\circ$ upwards and 5° downwards;
 $\beta = 25^\circ$ to right and to left.
- 6.11.6. Orientation
Rearwards.
- 6.11.7. Electrical connections
These shall be such that:
- 6.11.7.1. The rear fog-lamp(s) cannot be switched ON unless the main beams, dipped-beams or front fog-lamps are switched ON;
- 6.11.7.2. The rear fog-lamp(s) can be switched OFF independently of any other lamp;
- 6.11.7.3. Either of the following applies:
- 6.11.7.3.1. The rear fog lamp(s) may continue to operate until the position lamps are switched OFF, and the rear fog lamp(s) shall then remain OFF until deliberately switched ON again;
- 6.11.7.3.2. A warning, at least audible, additional to the mandatory tell-tale (paragraph 6.11.8.) shall be given if the ignition is switched OFF or the ignition key is withdrawn and the driver's door is opened, whether the lamps in paragraph 6.11.7.1. are ON or OFF, whilst the rear fog lamp control is in the ON position.
- 6.11.7.4. Except as provided in paragraphs 6.11.7.1., 6.11.7.3. and 6.11.7.5., the operation of the rear fog lamp(s) shall not be affected by switching ON or OFF any other lamps.
- 6.11.7.5. The rear fog lamp(s) of a drawing motor vehicle may be automatically switched OFF while a trailer is connected and the rear fog lamp(s) of the trailer is (are) switched ON.
- 6.11.8. Tell-tale
Circuit-closed tell-tale mandatory. An independent non-flashing warning light.
- 6.11.9. Other requirements
In all cases, the distance between the rear fog-lamp and each stop-lamp shall be greater than 100 mm.
- 6.12. Parking lamp (UN Regulation No. 77 or 7 or 148)

- 6.12.1. Presence
On motor vehicles not exceeding 6 m in length and not exceeding 2 m in width, optional.
On all other vehicles, prohibited.
- 6.12.2. Number
According to the arrangement.
- 6.12.3. Arrangement
Either two lamps at the front and two lamps at the rear, or one lamp on each side.
- 6.12.4. Position
- 6.12.4.1. In width: that point on the apparent surface in the direction of the reference axis which is farthest from the vehicle's median longitudinal plane shall not be more than 400 mm from the extreme outer edge of the vehicle.
Furthermore, if there are two lamps, they shall be on the sides of the vehicle.
- 6.12.4.2. In height:
For M₁ and N₁ category vehicles: no special requirement;
For all other categories of vehicles: above the ground, not less than 350 mm nor more than 1 500 mm (2 100 mm if the shape of the bodywork makes it impossible to keep within 1 500 mm).
- 6.12.4.3. In length: no special requirement.
- 6.12.5. Geometric visibility
Horizontal angle: 45° outwards, forwards and rearwards.
However, where a front or rear parking lamp is mounted below 750 mm (measured according to the provisions of paragraph 5.8.1. above), the inward angle of 45° may be reduced to 20° under the H plane.
Vertical angle: 15° above and below the horizontal.
However, where a lamp is mounted below 750 mm (measured according to the provisions of paragraph 5.8.1. above), the downward angle of 15° may be reduced to 5°.
- 6.12.6. Orientation
Such that the lamps meet the requirements for visibility forwards and rearwards.
- 6.12.7. Electrical connections
The connection shall allow the parking lamp(s) on the same side of the vehicle to be switched ON independently of any other lamps.
The parking lamp(s) and, if applicable, the front and rear position lamps according to paragraph 6.12.9. below, shall be able to operate even if the device which starts the propulsion system is in a position which makes it impossible for the propulsion system to operate. A device which automatically switches OFF these lamps as a function of time is prohibited.
- 6.12.8. Tell-tale
Circuit-closed tell-tale optional. If there is one, it shall not be possible to confuse it with the tell-tale for the front and rear position lamps.

6.12.9. Other requirements

The functioning of this lamp may also be performed by simultaneously switching ON the front and rear position lamps on the same side of the vehicle. In this case, lamps that meet the requirements of front or rear position lamps are deemed to meet the requirements of parking lamps.

6.13. End-outline marker lamp (UN Regulation No. 7 or 148)

6.13.1. Presence

Devices of A or AM categories (visible from the front), and devices of R, R₁, R₂, RM₁ or RM₂ Categories (visible from the rear):

Mandatory on vehicles exceeding 2.10 m in width. Optional on vehicles between 1.80 and 2.10 m in width. On chassis-cabs the rear end-outline marker lamps are optional.

6.13.2. Number

Two visible from the front and two visible from the rear.

Additional lamps may be fitted as follows:

- (a) Two visible from the front;
- (b) Two visible from the rear.

6.13.3. Arrangement

No special requirement.

6.13.4. Position

6.13.4.1. In width:

Front and rear: as close as possible to the extreme outer edge of the vehicle. This condition is deemed to have been met when the point on the apparent surface in the direction of the reference axis which is farthest from the vehicle's median longitudinal plane is not more than 400 mm from the extreme outer edge of the vehicle.

6.13.4.2. In height:

Front: Motor vehicles - the horizontal plane tangential to the upper edge of the apparent surface in the direction of the reference axis of the device shall not be lower than the horizontal plane tangential to the upper edge of the transparent zone of the wind-screen.

Trailers and semi-trailers - at the maximum height compatible with the requirements relating to the width, design and operational requirements of the vehicle and to the symmetry of the lamps.

Rear: At the maximum height compatible with the requirements relating to the width, design and operational requirements of the vehicle and to the symmetry of the lamps.

The additional lamps, as specified in paragraph 6.13.2. (b), shall be fitted as far separated in height as practicable in respect to the mandatory ones, provided that their position is compatible with design/operational requirements of the vehicle and symmetry of the lamps.

6.13.4.3. In length, no special requirement.

The additional lamps, as specified in paragraph 6.13.2. (a), shall be fitted as close as practicable to the rear; this requirement shall be deemed to be satisfied if the distance between the additional lamps and the rear of the vehicle does not exceed 400 mm.

- 6.13.5. Geometric visibility
Horizontal angle: 80° outwards.
Vertical angle: 5° above and 20° below the horizontal.
- 6.13.6. Orientation
Such that the lamps meet the requirements for visibility forwards and rearwards.
- 6.13.7. Electrical connections
In accordance with paragraph 5.11.
- 6.13.8. Tell-tale
Tell-tale optional. If it exists, its function shall be carried out by the tell-tale required for the front and rear position lamps.
However, a tell-tale indicating failure is mandatory if required by the component regulation.
- 6.13.9. Other requirements
Provided that all other requirements are met, the mandatory or optional lamps, visible from the front and the mandatory or optional lamps visible from the rear on the same side of the vehicle may be combined into one device.
Two of the lamps visible from the rear may be grouped, combined or reciprocally incorporated in accordance with paragraph 5.7.
The position of an end-outline marker lamp in relation to corresponding position lamp shall be such that the distance between the projections on a transverse vertical plane of the points nearest to one another on the apparent surfaces in the direction of the respective reference axes of the two lamps considered is not less than 200 mm.
The additional lamps, as specified in paragraph 6.13.2. (a), used to mark the rear end outline of the vehicle, the trailer or the semi-trailer shall be fitted in such a way to make it visible within the fields of vision of the approved main rear-view devices for indirect vision.
- 6.14. Rear retro-reflector, non-triangular (UN Regulation No. 3 or 150)
- 6.14.1. Presence
Mandatory on motor vehicles.
Provided that they are grouped together with the other rear light-signalling devices, optional on trailers.
- 6.14.2. Number
Two, the performances of which shall conform to the requirements concerning Class IA or IB retro-reflectors in UN Regulation No. 3 or 150. Additional retro-reflecting devices and materials (including two retro-reflectors not complying with paragraph 6.14.4. below), are permitted provided they do not impair the effectiveness of the mandatory lighting and light-signalling devices.
- 6.14.3. Arrangement
No special requirement.
- 6.14.4. Position
- 6.14.4.1. In width: that point on the illuminating surface which is farthest from the vehicle's median longitudinal plane shall not be more than 400 mm from the extreme outer edge of the vehicle.

The distance between the inner edges of the two apparent surfaces in the direction of the reference axes shall:

For M_1 and N_1 category vehicles: have no special requirement;

For all other categories of vehicles: be not less than 600 mm. This distance may be reduced to 400 mm where the overall width of the vehicle is less than 1 300 mm.

6.14.4.2. In height: Above the ground, not less than 250 mm nor more than 900 mm (not more than 1 200 mm if grouped with any rear lamp(s), 1 500 mm if the shape of the bodywork makes it impossible to keep within 900 mm or 1 200 mm respectively).

6.14.4.3. In length: at the rear of the vehicle.

6.14.5. Geometric visibility

Horizontal angle: 30° inwards and outwards.

Vertical angle: 10° above and below horizontal.

However, where a retro-reflector is mounted below 750 mm (measured according to the provisions of paragraph 5.8.1. above), the downward angle of 10° may be reduced to 5°.

6.14.6. Orientation

Rearwards.

6.14.7. Other requirements

The illuminating surface of the retro-reflector may have parts in common with the apparent surface of any other lamp situated at the rear.

6.15. Rear retro-reflector, triangular (UN Regulation No. 3 or 150)

6.15.1. Presence

Mandatory on trailers.

Prohibited on motor vehicles.

6.15.2. Number

Two, the performances of which shall conform to the requirements concerning Class IIIA or Class IIIB retro-reflectors in UN Regulation No. 3 or 150. Additional retro-reflecting devices and materials (including two retro-reflectors not complying with paragraph 6.15.4. below), are permitted provided they do not impair the effectiveness of the mandatory lighting and light-signalling devices.

6.15.3. Arrangement

The apex of the triangle shall be directed upwards.

6.15.4. Position

6.15.4.1. In width: that point on the illuminating surface which is farthest from the vehicle's median longitudinal plane shall not be more than 400 mm from the extreme outer edge of the vehicle.

The inner edges of the retro-reflectors shall not be less than 600 mm apart. This distance may be reduced to 400 mm if the overall width of the vehicle is less than 1 300 mm.

6.15.4.2. In height: Above the ground, not less than 250 mm nor more than 900 mm (not more than 1 200 mm if grouped with any rear lamp(s), 1 500 mm if the shape of the bodywork makes it impossible to keep within 900 mm or 1 200 mm respectively).

- 6.15.4.3. In length: at the rear of the vehicle.
- 6.15.5. Geometric visibility
Horizontal angle: 30° inwards and outwards.
Vertical angle: 15° above and below the horizontal. However, where a retro-reflector is mounted below 750 mm (measured according to the provisions of paragraph 5.8.1. above), the downward angle of 15° may be reduced to 5°.
- 6.15.6. Orientation
Rearwards.
- 6.15.7. Other requirements
The illuminating surface of the retro-reflector may have parts in common with the apparent surface of any other lamp situated at the rear.
- 6.16. Front retro-reflector, non-triangular (UN Regulation No. 3 or 150)
- 6.16.1. Presence
Mandatory on trailers.
Mandatory on motor vehicles having all forward facing lamps with reflectors concealable.
Optional on other motor vehicles.
- 6.16.2. Number
Two, the performances of which shall conform to the requirements concerning Class IA or IB retro-reflectors in UN Regulation No. 3 or 150. Additional retro-reflecting devices and materials (including two retro-reflectors not complying with paragraph 6.16.4. below), are permitted provided they do not impair the effectiveness of the mandatory lighting and light-signalling devices.
- 6.16.3. Arrangement
No special requirement.
- 6.16.4. Position
- 6.16.4.1. In width: that point on the illuminating surface which is farthest from the vehicle's median longitudinal plane shall not be more than 400 mm from the extreme outer edge of the vehicle.
In the case of a trailer, the point of the illuminating surface which is farthest from the vehicle's median longitudinal plane shall not be farther than 150 mm from the extreme outer edge of the vehicle.
The distance between the inner edges of the two apparent surfaces in the direction of the reference axes shall:
For M₁ and N₁ category vehicles: have no special requirement;
For all other categories of vehicles: be not less than 600 mm. This distance may be reduced to 400 mm where the overall width of the vehicle is less than 1 300 mm.
- 6.16.4.2. In height: above the ground, not less than 250 mm nor more than 900 mm (1 500 mm if the shape of the bodywork makes it impossible to keep within 900 mm).
- 6.16.4.3. In length: at the front of the vehicle.

6.16.5. Geometric visibility

Horizontal angle: 30° inwards and outwards. In the case of trailers, the angle inwards may be reduced to 10°. If because of the construction of the trailers this angle cannot be met by the mandatory retro-reflectors, then additional (supplementary) retro-reflectors shall be fitted, without the width limitation (paragraph 6.16.4.1. above), which shall, in conjunction with the mandatory retro-reflectors, give the necessary visibility angle.

Vertical angle: 10° above and below the horizontal. However, where a retro-reflector is mounted below 750 mm (measured according to the provisions of paragraph 5.8.1. above), the downward angle of 10° may be reduced to 5°.

6.16.6. Orientation

Towards the front.

6.16.7. Other requirements

The illuminating surface of the retro-reflector may have parts in common with the apparent surface of any other lamp situated at the front.

6.17. Side retro-reflector, non-triangular (UN Regulation No. 3 or 150)

6.17.1. Presence

Mandatory: On all motor vehicles the length of which exceeds 6 m.

On all trailers.

Optional: On motor vehicles the length of which does not exceed 6 m.

6.17.2. Number

Such that the requirements for longitudinal positioning are complied with. The performances of these devices shall conform to the requirements concerning Class IA or IB retro-reflectors in UN Regulation No. 3 or 150. Additional retro-reflecting devices and materials (including two retro-reflectors not complying with paragraph 6.17.4. below), are permitted provided they do not impair the effectiveness of the mandatory lighting and light-signalling devices.

6.17.3. Arrangement

No special requirement.

6.17.4. Position

6.17.4.1. In width: no special requirement.

6.17.4.2. In height: Above the ground, not less than 250 mm nor more than 900 mm (not more than 1 200 mm if grouped with any lamp(s), 1 500 mm if the shape of the bodywork makes it impossible to keep within 900 mm or 1 200 mm respectively or if the presence of the device is not mandatory according to paragraph 6.17.1.).

6.17.4.3. In length: at least one side retro-reflector shall be fitted to the middle third of the vehicle, the foremost side retro-reflector being not further than 3 m from the front;

The distance between two adjacent side retro-reflectors shall not exceed 3 m. This does not, however, apply to M₁ and N₁ category vehicles.

If the structure, design or the operational use of the vehicle makes it impossible to comply with such a requirement, this distance may be increased to 4 m. The distance between the rearmost side retro-reflector and the rear of the vehicle shall not exceed 1 m. However, for motor vehicles the length of which does not exceed 6 m, it is sufficient to have one side retro-reflector fitted within the first third and/or one within the last third of the vehicle length.

For M₁ vehicles the length of which exceeds 6 m but does not exceed 7 m it is sufficient to have one side retro-reflector fitted not further than 3 m from the front and one within the last third of the vehicle length.

6.17.5. Geometric visibility

Horizontal angle: 45° to the front and to the rear.

Vertical angle: 10° above and below the horizontal. However, where a retro-reflector is mounted below 750 mm (measured according to the provisions of paragraph 5.8.1. above), the downward angle of 10° may be reduced to 5°.

6.17.6. Orientation

Towards the side.

6.17.7. Other requirements

The illuminating surface of the side retro-reflector may have parts in common with the apparent surface of any other side lamp.

6.18. Side-marker lamps (UN Regulation No. 91 or 148)

6.18.1. Presence

Mandatory: On all vehicles the length of which exceeds 6 m, except for chassis-cabs.

The SM1 type of side-marker lamp shall be used on all categories of vehicles; however the SM2 type of side-marker lamps may be used on the M₁ category of vehicles.

In addition, on M₁ and N₁ category vehicles less than 6 m in length, side-marker lamps shall be used, if they supplement the reduced geometric visibility requirements of front position lamps conforming to paragraph 6.9.5.2. and rear position lamps conforming to paragraph 6.10.5.2.

Optional: On all other vehicles.

The SM1 or SM2 types of side-marker lamps may be used.

6.18.2. Minimum number per side

Such that the rules for longitudinal positioning are complied with.

6.18.3. Arrangement

No individual specifications.

6.18.4. Position

6.18.4.1. In width: no individual specifications.

6.18.4.2. In height: Above the ground, not less than 250 mm nor more than 1 500 mm (2 100 mm if the shape of the bodywork makes it impossible to keep within 1 500 mm).

6.18.4.3. In length: at least one side-marker lamp shall be fitted to the middle third of the vehicle, the foremost side-marker lamp being not further than 3 m from the front. The distance between two adjacent side-marker lamps shall not exceed 3 m. If the structure, design or the operational use of the vehicle make it impossible to comply with such a requirement, this distance may be increased to 4 m.

The distance between the rearmost side-marker lamp and the rear of the vehicle shall not exceed 1 m.

However, for vehicles the length of which does not exceed 6 m and for chassis-cabs it is sufficient to have one side-marker lamp fitted within the first third and/or within the last third of the vehicle length. For M₁ vehicles the length of which exceeds 6 m but does not exceed 7 m it is sufficient to have one side-marker lamp fitted not further than 3 m from the front and one within the last third of the vehicle length.

6.18.5. Geometric visibility

Horizontal angle: 45° to the front and to the rear; however for vehicles on which the installation of the side-marker lamps is optional this value can be reduced to 30°.

If the vehicle is equipped with side-marker lamps used to supplement the reduced geometric visibility of front and rear direction indicator lamps conforming to paragraph 6.5.5.2. above and/or position lamps conforming to paragraphs 6.9.5.2. and 6.10.5.2. above, the angles are 45° towards the front and rear ends of the vehicle and 30° towards the centre of the vehicle (see the figure in paragraph 6.5.5.2. above).

Vertical angle: 10° above and below the horizontal. However, where a lamp is mounted below 750 mm (measured according to the provisions of paragraph 5.8.1. above), the downward angle of 10° may be reduced to 5°.

6.18.6. Orientation

Towards the side.

6.18.7. Electrical connections

On M₁ and N₁ category vehicles less than 6 m in length amber side-marker lamps may be wired to flash, provided that this flashing is in phase and at the same frequency with the direction-indicator lamps at the same side of the vehicle.

On M₂, M₃, N₂, N₃, O₃ and O₄ vehicles mandatory amber side marker lamps may flash simultaneously with the direction-indicator lamps on the same side of the vehicle. However, where there are direction indicator lamps of category 5 installed according to paragraph 6.5.3.1. on the side of the vehicle these amber side marker lamps shall not flash.

6.18.8. Tell-tale

Tell-tale optional. If it exists its function shall be carried out by the tell-tale required for the front and rear position lamps.

6.18.9. Other requirements

When the rearmost side-marker lamp is combined with the rear position lamp reciprocally incorporated with the rear fog-lamp or stop lamp, the photometric characteristics of the side-marker lamp may be modified during the entire time of the rear fog lamp or stop lamp are switched ON.

Rear side-marker lamps shall be amber if they flash with the rear direction-indicator lamp.

6.19. Day-time running lamp (UN Regulation No. 87 or 148)

6.19.1. Presence

Mandatory on motor vehicles. Prohibited on trailers.

6.19.2. Number

Two.

6.19.3. Arrangement

No special requirement.

- 6.19.4. Position
- 6.19.4.1. In width: the distance between the inner edges of the apparent surfaces in the direction of the reference axes shall not be less than 600 mm.
This distance may be reduced to 400 mm where the overall width of the vehicle is less than 1 300 mm.
- 6.19.4.2. In height: above the ground not less than 250 mm nor more than 1 500 mm.
- 6.19.4.3. In length: at the front of the vehicle. This requirement shall be deemed to be satisfied if the light emitted does not cause discomfort to the driver either directly or indirectly through the devices for indirect vision and/or other reflecting surfaces of the vehicle.
- 6.19.5. Geometric visibility
Horizontal: outwards 20° and inwards 20°.
Vertical: upwards 10° and downwards 10°.
- 6.19.6. Orientation
Towards the front.
- 6.19.7. Electrical connections
- 6.19.7.1. The daytime running lamps shall be switched ON automatically when the device which starts and/or stops the propulsion system is set in a position which makes it possible for the propulsion system to operate. However, the daytime running lamps may remain OFF while the following conditions exist:
- 6.19.7.1.1. The automatic transmission control is in the park position; or
- 6.19.7.1.2. The parking brake is in the applied position; or
- 6.19.7.1.3. Prior to the vehicle being set in motion for the first time after each manual activation of the device, which starts and/or stops the propulsion system.
- 6.19.7.2. The daytime running lamps may be switched OFF manually, provided that they switch ON automatically when the vehicle speed exceeds 15 km/h or when the vehicle has travelled more than 100 m, and that they remain ON until deliberately switched OFF again.
- 6.19.7.3. The daytime running lamp shall switch OFF automatically when the device which starts and/or stops the propulsion system is set in a position which makes it impossible for the propulsion system to operate or the front fog lamps or headlamps are switched ON, except when the latter are used to give intermittent luminous warnings at short intervals.
- 6.19.7.4. The lamps referred to in paragraph 5.11. may be switched ON when the daytime running lamps are switched ON. If this option is chosen, at least the rear position lamps shall be switched ON.
- 6.19.7.5. If the distance between the front direction-indicator lamp and the daytime running lamp is equal or less than 40 mm, the electrical connections of the daytime running lamp on the relevant side of the vehicle may be such that either:
- (a) It is switched OFF; or

- (b) Its luminous intensity is reduced during the entire period (both ON and OFF cycle) of activation of a front direction-indicator lamp.
- 6.19.7.6. If a direction-indicator lamp is reciprocally incorporated with a daytime running lamp, the electrical connections of the daytime running lamp on the relevant side of the vehicle shall be such that the daytime running lamp is switched OFF during the entire period (both ON and OFF cycle) of activation of the direction-indicator lamp.
- 6.19.8. Tell-tale
Closed-circuit tell-tale optional, however a tell-tale indicating failure is mandatory if required by the component regulation.
- 6.19.9. Other prescriptions
No prescription.
- 6.20. Cornering lamp (UN Regulation No. 119 or 149)
- 6.20.1. Presence
Optional on motor vehicles.
- 6.20.2. Number
Two.
- 6.20.3. Arrangement
No special requirement.
- 6.20.4. Position
- 6.20.4.1. In width: one cornering lamp shall be located on each side of the vehicle's median longitudinal plane.
- 6.20.4.2. In length: not further than 1 000 mm from the front.
- 6.20.4.3. In height: minimum: Not less than 250 mm above the ground;
maximum: Not more than 900 mm above the ground.
However, no point on the apparent surface in the direction of the reference axis shall be higher than the highest point on the apparent surface in the direction of the reference axis of the dipped-beam headlamp.
- 6.20.5. Geometric visibility
Defined by angles α and β as specified in paragraph 2.10.7.:
 $\alpha = 10^\circ$ upwards and downwards,
 $\beta = 30^\circ$ to 60° outwards .
- 6.20.6. Orientation
Such that the lamps meet the requirements for geometric visibility.
- 6.20.7. Electrical connections
The cornering lamps shall be so connected that they cannot be switched ON unless the main-beam headlamps or the dipped-beam headlamps are switched ON at the same time.

- 6.20.7.1. The cornering lamp on one side of the vehicle may only be switched ON automatically when the direction-indicators on the same side of the vehicle are switched ON and/or when the steering angle is changed from the straight-ahead position towards the same side of the vehicle.
- The cornering lamp shall be switched OFF automatically when the direction-indicator is switched OFF and/or the steering angle has returned in the straight-ahead position.
- 6.20.7.2. When the reversing lamp is switched ON, both cornering lamps may be switched ON simultaneously, independently from the steering wheel position or direction-indicator operation.
- If so switched ON, both cornering lamps shall be switched OFF either:
- (a) When the reversing lamp is switched OFF;
 - or
 - (b) When the forward speed of the vehicle exceeds 15 km/h.
- 6.20.8. Tell-tale
- None.
- 6.20.9. Other requirements
- The cornering lamps shall not be switched ON at vehicle speeds above 40 km/h.
- 6.21. Conspicuity markings (UN Regulation No. 104 or 150)
- 6.21.1. Presence
- 6.21.1.1. Prohibited: on vehicles of categories M₁ and O₁.
- 6.21.1.2. Mandatory:
- 6.21.1.2.1. To the rear:
- Full contour marking on vehicles exceeding 2 100 mm in width of the following categories:
- (a) N₂ with a maximum mass exceeding 7.5 tonnes and N₃ (with the exception of chassis-cabs, incomplete vehicles and tractors for semi-trailers);
 - (b) O₃ and O₄ (with the exception of incomplete vehicles)
- 6.21.1.2.2. To the side:
- 6.21.1.2.2.1. Partial contour marking on vehicles exceeding 6 000 mm in length (including the drawbar for trailers) of the following categories:
- (a) N₂ with a maximum mass exceeding 7.5 tonnes and N₃ (with the exception of chassis-cabs, incomplete vehicles and tractors for semi-trailers);
 - (b) O₃ and O₄ (with the exception of incomplete vehicles)
- 6.21.1.2.3. A line marking may be installed instead of the mandatory contour marking if the shape, structure, design or operational requirements of the vehicle make it impossible to install the mandatory contour marking.
- 6.21.1.2.4. If the exterior surfaces of the bodywork are partially constituted of flexible material, this line marking shall be installed on (a) rigid part(s) of the vehicle. The remaining portion of conspicuity markings may be fitted on the flexible material. If the exterior surfaces of the bodywork are constituted fully of flexible material, the line marking may be fitted on the flexible material.

- 6.21.1.2.5. In cases where the manufacturer, after verification by the Technical Service, can prove to the satisfaction of the Type Approval Authority that it is impossible, due to the operational requirements which may require special shape, structure or design of the vehicle, to comply with the requirements contained in paragraphs 6.21.2. to 6.21.7.5. below, then partial fulfilment of some of these requirements is acceptable. This is conditional upon a portion of the requirements being met where possible, and the application of conspicuity markings that partially meet requirements maximised on the vehicle structure. This may include fitting of additional brackets or plates containing material compliant with UN Regulation No. 104 or 150 where structure is available to ensure clear and uniform signalling compatible with the objective of conspicuity.

Where partial fulfilment is deemed acceptable, retro-reflective devices like retro-reflectors of class IVA of UN Regulation No. 3 or 150 or brackets containing retro-reflecting material compliant with photometric requirements of Class C of UN Regulation No. 104 or 150 may substitute part of the required conspicuity markings. In this case, at least one of these retro-reflective devices shall be installed per 1 500 mm.

The necessary information shall be indicated in the communication form.

- 6.21.1.3. Optional:

- 6.21.1.3.1. To the rear and to the side:

On all other categories of vehicles, not otherwise specified in paragraphs 6.21.1.1. and 6.21.1.2. above, including the cab of tractor units for semi-trailers and the cab of chassis-cabs.

Partial or full contour marking may be applied instead of mandatory line markings, and full contour marking may be applied instead of mandatory partial contour marking.

- 6.21.1.3.2. To the front:

Line marking on vehicles of categories O₂, O₃ and O₄.

Partial or full contour marking may not be applied to the front.

- 6.21.2. Number

According to the presence.

- 6.21.3. Arrangement

The conspicuity markings shall be as close as practicable to horizontal and vertical, compatible with the shape, structure, design and operational requirements of the vehicle; if this is not possible, the full or partial contour markings, when fitted, shall follow as close as practicable the contour of the outer shape of the vehicle.

Furthermore, the conspicuity markings shall be spaced as evenly as possible over the horizontal dimensions of the vehicle such that the total length and/or width of the vehicle can be identified.

- 6.21.4. Position

- 6.21.4.1. Width

- 6.21.4.1.1. The conspicuity marking shall be as close as practicable to the edge of the vehicle.

6.21.4.1.2. The cumulative horizontal length of the conspicuity marking elements, as mounted on the vehicle, shall equate to at least 70 per cent of the overall width of the vehicle, excluding any horizontal overlap of individual elements.

6.21.4.2. Length

6.21.4.2.1. The conspicuity marking shall be as close as practicable to the ends of the vehicle and reach to within 600 mm of each end of the vehicle.

6.21.4.2.1.1. For motor vehicles, each end of the vehicle, or in the case of tractors for semi-trailers each end of the cab ;

However, an alternative marking mode within 2 400 mm from the front end of the motor vehicle is allowed where a series of retro-reflectors of Class IVA of UN Regulation No. 3 or 150 or Class C of UN Regulation No. 104 or 150 are mounted followed by the required conspicuity marking as follows:

- (a) Retro-reflector size minimum 25 cm²;
- (b) One retro-reflector mounted not more than 600 mm from the front end of the vehicle;
- (c) Additional retro-reflectors spaced not more than 600 mm apart;
- (d) The distance between the last retro-reflector and the start of the conspicuity marking shall not exceed 600 mm;

6.21.4.2.1.2. For trailers, each end of the vehicle (excluding the drawbar).

6.21.4.2.2. The cumulative horizontal length of the conspicuity marking elements, as mounted on the vehicle, excluding any horizontal overlap of individual elements, shall equate to at least 70 per cent of:

6.21.4.2.2.1. For motor vehicles, length of vehicle, or in the case of tractors for semi-trailers, if fitted, the length of the cab; however, when using the alternative marking mode per paragraph 6.21.4.2.1.1., the distance beginning within 2 400 mm from the front end of vehicle to its rear end.

Motor vehicle

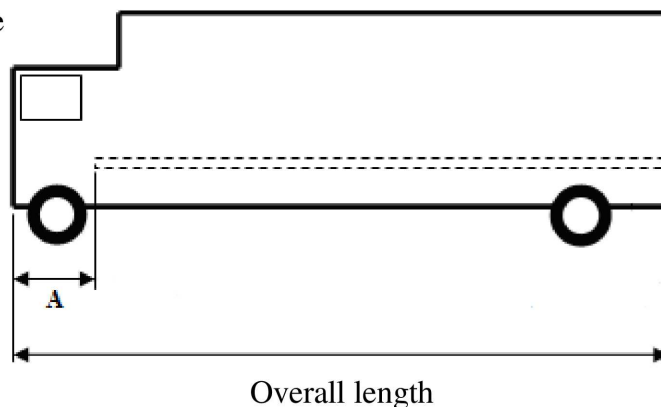

A is the distance between the foremost conspicuity marking and the front end of the vehicle. The maximum value of A is 2 400 mm (see paragraph 6.21.4.2.1.1.).

6.21.4.2.2.2. For trailers, the overall length of the vehicle (excluding the drawbar).

Trailer

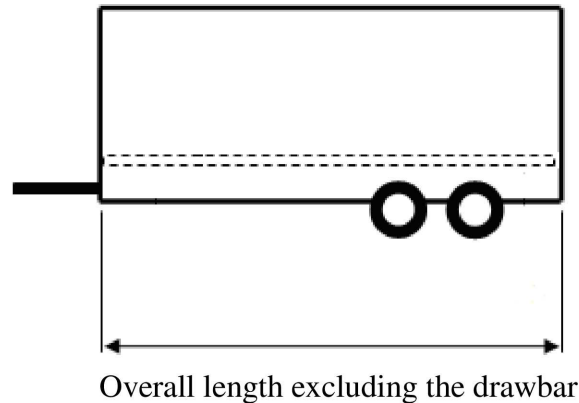

6.21.4.3. Height

6.21.4.3.1. Line markings and contour markings lower element(s)

As low as practicable within the range:

Minimum: not less than 250 mm above the ground.

Maximum: not more than 1 500 mm above the ground.

However, a maximum mounting height of 2 500 mm may be accepted where the shape, structure, design or operational conditions of the vehicle prevent compliance with the maximum value of 1 500 mm or, if necessary, to fulfil the requirements of paragraphs 6.21.4.1.2., and 6.21.4.2.2., or the horizontal positioning of the line marking or the lower element(s) of the contour marking.

The necessary justification for installation of conspicuity material higher than 1 500 mm shall be indicated in the communication form.

6.21.4.3.2. Contour markings upper element(s):

As high as practicable, but within 400 mm of the upper extremity of the vehicle.

6.21.5. Visibility

The conspicuity marking shall be considered visible, if at least 70 per cent of the illuminating surface of the installed marking is visible when viewed by an observer positioned at any point within the observation planes defined below:

6.21.5.1. For rear and front conspicuity markings (see Annex 11, Figures 1a and 1b) the observation plane is perpendicular to the longitudinal axis of the vehicle situated 25 m from the extreme end of the vehicle and bounded by:

6.21.5.1.1. In height, by two horizontal planes 1 m and 3.0 m respectively above the ground;

6.21.5.1.2. In width, by two vertical planes which form an angle of 4° outwards from the vehicle's median longitudinal plane and which pass through the intersection of the vertical planes parallel to the vehicle's median longitudinal plane delimiting the vehicle's overall width, and the plane perpendicular to the longitudinal axis of the vehicle that delimits the end of the vehicle.

6.21.5.2. For side conspicuity markings (see Annex 11, Fig. 2) the observation plane is parallel to the longitudinal median plane of the vehicles situated 25 m from the extreme outer edge of the vehicle and bounded by:

6.21.5.2.1. In height, by two horizontal planes 1.0 m and 1.5 m respectively above the ground;

- 6.21.5.2.2. In width, by two vertical planes which form an angle of 4° outwards from a plane perpendicular to the vehicle's longitudinal axis and which pass through the intersection of the vertical planes perpendicular to the vehicle's longitudinal axis delimiting the vehicle's overall length and the extreme outer edge of the vehicle.
- 6.21.6. Orientation
- 6.21.6.1. To the side:
As close as practicable to being parallel to the median longitudinal plane of the vehicle, compatible with the shape, structure, design and operation requirements of the vehicle; if this is not possible, it shall follow as close as practicable the contour of the outer shape of the vehicle.
- 6.21.6.2. To the rear and to the front:
As close as practicable to being parallel to the transverse plane of the vehicle, compatible with the shape, structure, design and operation requirements of the vehicle, if this is not possible, it shall follow as close as practicable the contour of the outer shape of the vehicle.
- 6.21.7. Other requirements
- 6.21.7.1. Conspicuity markings shall be considered continuous if the distance between adjacent elements are as small as possible and do not exceed 50 per cent of the shortest adjacent element length. However, if the manufacturer can prove to the satisfaction of the Type Approval Authority that it is impossible to respect the value of 50 per cent, the distance between adjacent elements may be larger than 50 per cent of the shortest adjacent element, and it shall be as small as possible and not exceed 1 000 mm.
- 6.21.7.2. In the case of a partial contour marking, each upper corner shall be described by two lines at 90°, to each other and each at least 250 mm in length; if this is not possible, the marking shall follow as close as practicable the contour of the outer shape of the vehicle.
- 6.21.7.3. The distance between the conspicuity marking fitted to the rear of a vehicle and each mandatory stop lamp should be greater than 200 mm.
- 6.21.7.4. Where rear marking plates conforming either to the 01 series of amendments to UN Regulation No. 70 or to UN Regulation No. 150 are installed these may be considered, at the discretion of the manufacturer, as part of the conspicuity marking to the rear, for the purposes of calculating the length of the conspicuity marking and its proximity to the side of the vehicle.
- 6.21.7.5. The locations on the vehicle designated for conspicuity markings shall allow for the installation of markings of at least 60 mm in width.
- 6.22. Adaptive front lighting system (AFS) (UN Regulation No. 123 or 149)
Where not otherwise specified below, the requirements for main-beam headlamps (paragraph 6.1.) and for dipped-beam headlamps (paragraph 6.2.) of this Regulation apply to the relevant part of the AFS.
- 6.22.1. Presence
Optional on motor vehicles. Prohibited on trailers.
- 6.22.2. Number
One.

6.22.3. Arrangement

No special requirements.

6.22.4. Position

The AFS shall, prior to the subsequent test procedures, be set to the neutral state;

6.22.4.1. In width and height:

For a given lighting function or mode the requirements indicated in the paragraphs 6.22.4.1.1. through 6.22.4.1.4. below shall be fulfilled by those lighting units which are energized simultaneously for that lighting function or mode of a function, according to the applicant's description.

All dimensions refer to the nearest edge of the apparent surface(s) observed in the direction of the reference axis, of the lighting unit(s).

6.22.4.1.1. Two symmetrically placed lighting units shall be positioned at a height in compliance with the requirements of the relevant paragraphs 6.1.4. and 6.2.4., where "Two symmetrically placed lighting units" shall be understood to be two lighting units, one on each side of the vehicle, positioned such that the (geometric) centres of gravity of their apparent surfaces are at the same height and at the same distance from the vehicle's longitudinal median plane within a tolerance of 50 mm, each; their light emitting surfaces, illuminating surfaces, and light outputs, however, may differ.

6.22.4.1.2. Additional lighting units, if any, on either side of the vehicle shall be positioned at a distance not exceeding 140 mm ⁽¹⁴⁾ in horizontal direction (E in the figure) and 400 mm in vertical direction above or below (D in the figure) from the nearest lighting unit;

6.22.4.1.3. None of the additional lighting units described in paragraph 6.22.4.1.2. above shall be positioned lower than 250 mm (F in the figure) nor higher than indicated in paragraph 6.2.4.2. of this Regulation (G in the figure) above the ground;

6.22.4.1.4. Additionally, in width:

For each mode of the passing-beam lighting:

The outer edge of the apparent surface of at least one lighting unit on each side of the vehicle shall not be more than 400 mm from the extreme outer edge of the vehicle (A in the figure); and,

The inner edges of the apparent surfaces in the direction of the reference axes shall be not less than 600 mm apart. This does not apply, however, for M₁ and N₁ category vehicles; for all other categories of motor vehicles this distance may be reduced to 400 mm where the overall width of the vehicle is less than 1 300 mm.

⁽¹⁴⁾ In case of additional "two symmetrically placed lighting units" the horizontal distance may be 200 mm (C in the figure).

Apparent surfaces of lighting units 1 through 11 of an AFS (example)

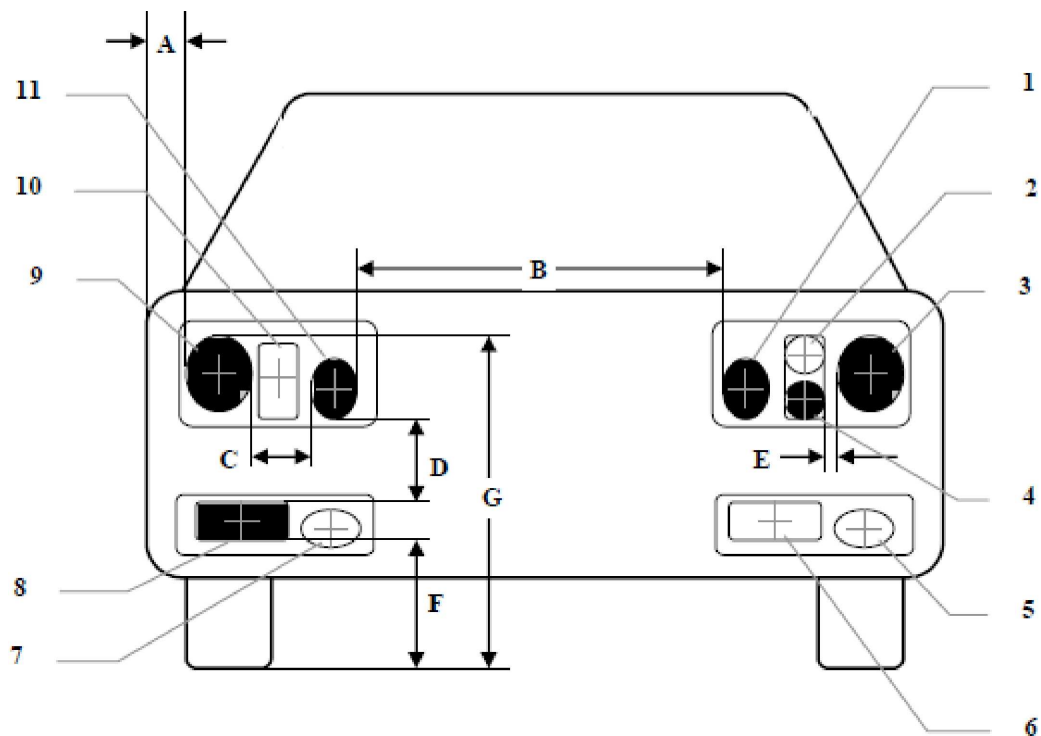

Lighting units being simultaneously energized for a given lighting mode:

No. 3 and 9: (two symmetrically placed lighting units)

No. 1 and 11: (two symmetrically placed lighting units)

No. 4 and 8: (two additional lighting units)

Lighting units not being energized for said lighting mode:

No. 2 and 10: (two symmetrically placed lighting units)

No. 5: (additional lighting unit)

No. 6 and 7: (two symmetrically placed lighting units)

Horizontal dimensions in mm:

$$A \leq 400$$

$B \geq 600$, or, ≥ 400 if vehicle overall width $< 1\,300$ mm, however no requirement for category M_1 and N_1 vehicles

$$C \leq 200$$

$$E \leq 140$$

Vertical dimensions in mm:

$$D \leq 400$$

$$F \geq 250$$

$$G \leq 1\,200$$

6.22.4.2. In length:

All lighting units of an AFS shall be mounted at the front. This requirement is deemed to be satisfied if the light emitted does not cause discomfort to the driver either directly or indirectly through the devices for indirect vision and/or other reflecting surfaces of the vehicle.

6.22.5. Geometric visibility

On each side of the vehicle, for each lighting function and mode provided:

The angles of geometric visibility prescribed for the respective lighting functions according to paragraphs 6.1.5. and 6.2.5. of this Regulation, shall be met by at least one of the lighting units that are simultaneously energized to perform said function and mode(s), according to the description of the applicant. Individual lighting units may be used to comply with the requirements for different angles.

6.22.6. Orientation

Towards the front.

The AFS shall, prior to the subsequent test procedures, be set to the neutral state, emitting the basic passing-beam.

6.22.6.1. Vertical orientation:

6.22.6.1.1. The initial downward inclination of the cut-off of the basic passing-beam to be set in the unladen vehicle state with one person in the driver's seat shall be specified with a precision of 0,1 per cent by the manufacturer and indicated in clearly legible and indelible manner on each vehicle, close to either the front lighting system or the manufacturer's plate, by the symbol shown in Annex 7.

Where differing initial downward inclinations are specified by the manufacturer for different lighting units that provide or contribute to the cut-off of the basic passing-beam, these values of downward inclination shall be specified with a precision of 0,1 per cent by the manufacturer and indicated in clearly legible and indelible manner on each vehicle, close to either the relevant lighting units or on the manufacturers plate, in such a way that all the lighting units concerned can be unambiguously identified.

6.22.6.1.2. The downward inclination of the horizontal part of the "cut-off" of the basic passing-beam shall remain between the limits indicated in paragraph 6.2.6.1.2. of this Regulation under all the static loading conditions of the vehicle of Annex 5 to this Regulation; and the initial aiming shall be within the specified values.

6.22.6.1.2.1. In case the passing-beam is generated by several beams from different lighting units, the provisions according to paragraph 6.22.6.1.2. above apply to each said beam's "cut-off" (if any), which is designed to project into the angular zone, as indicated under item 9.3. of the communication form conforming to the model in Annex 1 to UN Regulation No. 123 or item 9.3.3. in Annex 1 to UN Regulation No. 149.

6.22.6.2. Headlamp levelling device

6.22.6.2.1. In the case where a headlamp levelling device is necessary to satisfy the requirements of paragraph 6.22.6.1.2., the device shall be automatic.

6.22.6.2.2. In the event of a failure of this device, the passing-beam shall not assume a position in which the dip is less than it was at the time when the failure of the device occurred.

6.22.6.3. Horizontal orientation:

For each lighting unit the kink of the elbow of the cut-off line, if any, when projected on the screen, shall coincide with the vertical line through the reference axis of said lighting unit. A tolerance of 0.5 degree to that side which is the side of the traffic direction shall be allowed. Other lighting units shall be adjusted according to the applicant's specification, as defined according to Annex 10 of UN Regulation No. 123 or Annex 14 of UN Regulation No. 149.

6.22.6.4. Measuring procedure:

After adjustment of the initial setting of beam orientation, the vertical inclination of the passing-beam or, when applicable, the vertical inclinations of all the different lighting units that provide or contribute to the cut-off(s) according to paragraph 6.22.6.1.2.1. above of the basic passing-beam, shall be verified for all loading conditions of the vehicle in accordance with the specifications in paragraphs 6.2.6.3.1. and 6.2.6.3.2. of this Regulation.

6.22.7. Electrical connections

6.22.7.1. Main-beam lighting (if provided by the AFS)

6.22.7.1.1. The lighting units for the main-beam may be switched ON either simultaneously or in pairs. For changing over from the dipped-beam to the main-beam at least one pair of lighting units for the main-beam shall be switched ON. For changing over from the main-beam to the dipped-beam all lighting units for the main-beam shall be switched OFF simultaneously.

6.22.7.1.2. The main-beam may be designed to be adaptive, subject to the provisions in paragraph 6.22.9.3., the control signals being produced by a sensor system which is capable of detecting and reacting to each of the following inputs:

- (a) Ambient lighting conditions;
- (b) The light emitted by the front lighting devices and front light-signalling devices of oncoming vehicles;
- (c) The light emitted by the rear light-signalling of preceding vehicles;

Additional sensor functions to improve performance are allowed.

For the purpose of this paragraph, "vehicles" means vehicles of categories L, M, N, O, T, as well as bicycles, such vehicles being equipped with retro-reflectors, with lighting and light-signalling devices, which are switched ON.

6.22.7.1.3. It shall always be possible to switch the main-beam headlamps, adaptive or non-adaptive, ON and OFF manually and to manually deactivate the automatic control.

Moreover, the switching OFF, of the main-beam headlamps and the deactivation of their automatic control shall be by means of a simple and immediate manual operation; the use of sub-menus is not allowed.

6.22.7.1.4. The dipped-beams may remain switched ON at the same time as the main beams.

6.22.7.1.5. Where four concealable lighting units are fitted their raised position shall prevent the simultaneous operation of any additional headlamps fitted, if these are intended to provide light signals consisting of intermittent switching ON at short intervals (see paragraph 5.12.) in daylight.

6.22.7.2. Passing-beam lighting:

- (a) The control for changing over to the dipped-beam shall switch OFF all main-beam headlamps or switch OFF all AFS lighting units for the main-beam simultaneously;
- (b) The dipped-beam may remain switched ON at the same time as the main-beams;
- (c) In the case of lighting units for the dipped-beam being equipped with gas discharge light sources, the gas-discharge light sources shall remain switched ON during the main-beam operation.

6.22.7.3. The dipped-beam headlamps switching ON and OFF shall fulfil the requirements for "Electrical connection" in paragraph 5.12. and 6.2.7. of this Regulation.

6.22.7.4. Automatic operation of the AFS

The changes within and between the provided classes and their modes of the AFS lighting functions as specified below, shall be performed automatically without causing discomfort, distraction or glare, neither for the driver nor for other road users.

The following conditions apply for the activation of the classes and their modes of the passing-beam and, where applicable, of the main-beam and/or the adaptation of the main-beam.

6.22.7.4.1. The class C mode(s) of the passing-beam shall be activated if no mode of another passing-beam class is activated.

6.22.7.4.2. The class V mode(s) of the passing-beam shall not operate unless one or more of the following conditions is/are automatically detected (V-signal applies):

- (a) Roads in built-up areas and the vehicle's speed not exceeding 60 km/h;
- (b) Roads equipped with a fixed road illumination, and the vehicle's speed not exceeding 60 km/h;
- (c) A road surface luminance of 1 cd/m² and/or a horizontal road illumination of 10 lx being exceeded continuously;
- (d) The vehicle's speed not exceeding 50 km/h.

6.22.7.4.3. The class E mode(s) of the passing-beam shall not operate unless the vehicle's speed exceeds 60 km/h and one or more of the following conditions is/are automatically detected:

- (a) The road characteristics correspond to motorway conditions ⁽¹⁵⁾ or the vehicle's speed exceeds 110 km/h (E-signal applies);
- (b) In case of a class E mode of the passing-beam which, according to the system's approval documents / communication sheet, complies with a "data set" of UN Regulation No. 123, Annex 3, Table 6, or of UN Regulation No. 149, Table 14 only.

Data set E1: The vehicle's speed exceeds 100 km/h (E1-signal applies);

Data set E2: The vehicle's speed exceeds 90 km/h (E2-signal applies);

Data set E3: The vehicle's speed exceeds 80 km/h (E3-signal applies).

6.22.7.4.4. The class W-mode(s) of the passing-beam shall not operate unless the front fog lamps, if any, are switched OFF and one or more of the following conditions is/are automatically detected (W-signal applies):

- (a) The wetness of the road has been detected automatically;
- (b) The windshield wiper is operating and its continuous or automatically controlled operation has occurred for a period of at least two minutes.

6.22.7.4.5. A mode of a class C, V, E, or W passing-beam shall not be modified to become a bending mode of said class (T-signal applies in combination with the signal of said passing-beam class according to paragraphs 6.22.7.4.1. through 6.22.7.4.4. above) unless at least one of the following characteristics (or equivalent indications) are evaluated:

- (a) The angle of lock of the steering;
- (b) The trajectory of the centre of gravity of the vehicle.

⁽¹⁵⁾ Traffic directions being separated by means of road construction, or, a corresponding lateral distance of opposing traffic is identified. This implies a reduction of undue glare from vehicles headlamps in opposing traffic.

In addition the following provisions apply:

- (i) A horizontal movement of the asymmetric cut-off side-wards from the longitudinal axis of the vehicle, if any, is allowed only when the vehicle is in forward motion ⁽¹⁶⁾ and shall be such that the longitudinal vertical plane through the kink of the elbow of the cut-off does not intersect the line of the trajectory of the centre of gravity of the vehicle at distances from the front of the vehicle which are larger than 100 times the mounting height of the respective lighting unit;
- (ii) One or more lighting units may be additionally energized only when the horizontal radius of curvature of the trajectory of the centre of gravity of the vehicle is 500 m or less.

6.22.7.5. It shall always be possible for the driver to set the AFS to the neutral state and to return it to its automatic operation.

6.22.8. Tell-tale:

6.22.8.1. The provisions of paragraphs 6.1.8. (for the main-beam headlamp) and 6.2.8. (for the dipped-beam headlamp) of this Regulation apply to the respective parts of an AFS.

6.22.8.2. A visual failure tell-tale for AFS is mandatory. It shall be non-flashing. It shall be activated whenever a failure is detected with respect to the AFS control signals or when a failure signal is received in accordance with paragraph 5.9. of UN Regulation No. 123. It shall remain activated while the failure is present. It may be cancelled temporarily but shall be repeated whenever the device which starts and stops the propulsion system is switched ON and OFF.

6.22.8.3. If the main-beam is adaptive, a visual tell-tale shall be provided to indicate to the driver that the adaptation of the main beam is activated. This information shall remain displayed as long as the adaptation is activated.

6.22.8.4. A tell-tale to indicate that the driver has set the system into a state according to paragraph 5.8. of UN Regulation No. 123 or paragraph 4.12. of UN Regulation No. 149 is optional .

6.22.9. Other requirements

6.22.9.1. An AFS shall be permitted only in conjunction with the installation of headlamp cleaning device(s) according to UN Regulation No. 45 ⁽¹⁷⁾ for at least those lighting units, which are indicated under item 9.2.3. of the communication form conforming to the model in Annex 1 to UN Regulation No. 123 or under item 9.3.2.3. in Annex 1 to UN Regulation No. 149, if the total objective luminous flux of the light sources of these units exceeds 2 000 lm per side, and which contribute to the Class C (basic) passing-beam.

6.22.9.2. Verification of compliance with AFS automatic operating requirements

6.22.9.2.1. The applicant shall demonstrate with *a concise description* or other means acceptable to the Type Approval Authority:

- (a) The correspondence of the *AFS control signals*
 - i) To the description required in paragraph 3.2.6. of this Regulation; and
 - ii) To the respective AFS control signals specified in the AFS type approval documents; and

⁽¹⁶⁾ This provision does not apply for passing-beam lighting when bend lighting is produced for a right turn in right hand traffic (left turn in left-hand traffic).

⁽¹⁷⁾ Contracting Parties to the respective Regulations can still prohibit the use of mechanical cleaning systems when headlamps with plastic lenses, marked 'PL', are installed.

(b) Compliance with the *automatic operating* requirements according to paragraphs 6.22.7.4.1. through 6.22.7.4.5. above.

6.22.9.2.2. To verify, whether, according to the paragraph 6.22.7.4., the AFS automatic operation of the passing-beam functions does not cause any discomfort, the technical service shall perform a test drive which comprises any situation relevant to the system control on the basis of the applicants description; it shall be notified whether all modes are activated, performing and de-activated according to the applicant's description; obvious malfunctioning, if any, shall be contested (e.g. excessive angular movement or flicker).

6.22.9.2.3. The overall performance of the automatic control shall be demonstrated by the applicant by documentation or by other means accepted by the Type Approval Authority. Furthermore the manufacturer shall provide a documentation package which gives access to the design of "the safety concept" of the system. This "safety concept" is a description of the measures designed into the system, for example within the electronic units, so as to address system integrity and thereby ensure safe operation even in the event of mechanical or electrical failure which could cause any discomfort, distraction or glare, either to the driver or to oncoming and preceding vehicles. This description shall also give a simple explanation of all the control functions of the "system" and the methods employed to achieve the objectives, including a statement of the mechanism(s) by which control is exercised.

A list of all input and sensed variables shall be provided and the working range of these shall be defined. The possibility of a fall-back to the basic passing-beam (class C) function shall be a part of the safety concept.

The functions of the system and the safety concept, as laid down by the manufacturer, shall be explained. The documentation shall be brief, yet provide evidence that the design and development has had the benefit of expertise from all the system fields which are involved.

For periodic technical inspections, the documentation shall describe how the current operational status of the "system" can be checked.

For Type Approval purposes this documentation shall be taken as the basic reference for the verification process.

6.22.9.2.4. To verify, that the adaptation of the main-beam does not cause any discomfort, distraction or glare, neither to the driver nor to oncoming and preceding vehicles, the technical service shall perform a test drive according to paragraph 2. in Annex 12. This shall include any situation relevant to the system control on the basis of the applicant's description. The performance of the adaptation of the main-beam shall be documented and checked against the applicant's description. Any obvious malfunctioning shall be contested (e.g. excessive angular movement or flicker).

6.22.9.3. Adaptation of the main-beam

6.22.9.3.1. The sensor system used to control the adaptation of the main-beam, as described in paragraph 6.22.7.1.2., shall comply with the following requirements:

6.22.9.3.1.1. The boundaries of the minimum fields in which the sensor is able to detect light emitted from other vehicles as defined in paragraph 6.22.7.1.2. above are given by the angles indicated in paragraph 6.1.9.3.1.1. of this Regulation.

6.22.9.3.1.2. The sensor system sensitivity shall comply with the requirements in paragraph 6.1.9.3.1.2. of this Regulation.

- 6.22.9.3.1.3. The adaptive main-beam shall be switched OFF when the illuminance produced by ambient lighting conditions exceeds 7 000 lx.

Compliance with this requirement shall be demonstrated by the applicant, using simulation or other means of verification accepted by the Type Approval Authority. If necessary the illuminance shall be measured on a horizontal surface, with a cosine corrected sensor on the same height as the mounting position of the sensor on the vehicle. This may be demonstrated by the manufacturer by sufficient documentation or by other means accepted by the Type Approval Authority.

- 6.22.9.4. The aggregate maximum intensity of the lighting units that can be energized simultaneously to provide the main-beam lighting or its modes, if any, shall not exceed 430 000 cd, which corresponds to a reference value of 100.

This maximum intensity shall be obtained by adding together the individual reference marks indicated on the several installation units that are simultaneously used to provide the main-beam.

- 6.22.9.5. The means according to the provisions of paragraph 5.8. of UN Regulation No 123 or paragraph 4.12 of UN Regulation No. 149, which allow the vehicle to be used temporarily in a territory with the opposite direction of driving than that for which approval is sought, shall be explained in detail in the owner's manual.

6.23. Emergency stop signal

6.23.1. Presence

Mandatory on motor vehicles.

Optional on trailers.

The emergency stop signal shall be given by the simultaneous operation of all the stop or direction-indicator lamps fitted as described in paragraph 6.23.7.

6.23.2. Number

As specified in paragraph 6.5.2. or 6.7.2.

6.23.3. Arrangement

As specified in paragraph 6.5.3. or 6.7.3.

6.23.4. Position

As specified in paragraph 6.5.4. or 6.7.4.

6.23.5. Geometric visibility

As specified in paragraph 6.5.5. or 6.7.5.

6.23.6. Orientation

As specified in paragraph 6.5.6. or 6.7.6.

6.23.7. Electrical connections

- 6.23.7.1. All the lamps of the emergency stop signal shall flash in phase at a frequency of $4,0 \pm 1,0$ Hz.

- 6.23.7.1.1. However, if any of the lamps of the emergency stop signal to the rear of the vehicle use filament light sources the frequency shall be $4,0 +0,0/-1,0$ Hz.

- 6.23.7.2. The emergency stop signal shall operate independently of other lamps.

- 6.23.7.3. The emergency stop signal shall be switched ON and OFF automatically.

- 6.23.7.3.1. The emergency stop signal shall be switched ON only when the vehicle speed is above 50 km/h and the braking system is providing the emergency braking logic signal defined in UN Regulations Nos. 13 and 13-H.
- 6.23.7.3.2. The emergency stop signal shall be automatically switched OFF if the emergency braking logic signal as defined in UN Regulations Nos. 13 and 13-H is no longer provided or if the hazard warning signal is activated.
- 6.23.8. Tell-tale
Optional
- 6.23.9. Other requirements
- 6.23.9.1. Except as provided in paragraph 6.23.9.2. below, if a motor vehicle is equipped to tow a trailer, the control of the emergency stop signal on the motor vehicle shall also be capable of operating the emergency stop signal on the trailer.

When the motor vehicle is electrically connected to a trailer, the operating frequency of the emergency stop signal for the combination shall be limited to the frequency specified in paragraph 6.23.7.1.1. However, if the motor vehicle can detect that filament light sources are not being used on the trailer for the emergency stop signal, the frequency may be that specified in paragraph 6.23.7.1.
- 6.23.9.2. If a motor vehicle is equipped to tow a trailer fitted with a service braking system of either continuous or semi-continuous type, as defined in Regulation No.13, it shall be ensured that a constant power supply is provided via the electrical connector for the stop lamps to such trailers while the service brake is applied.

The emergency stop signal on any such trailer may operate independently of the towing vehicle and is not required to operate either at the same frequency as, or in phase with that on the towing vehicle.
- 6.24. Exterior courtesy lamp
- 6.24.1. Presence
Optional on motor vehicles
- 6.24.2. Number

Two, however further exterior courtesy lamps to illuminate steps and/or door handles are permitted. Each door handle or step shall be illuminated by not more than one lamp.
- 6.24.3. Arrangement

No special requirement, however the requirements of paragraph 6.24.9.3. apply.
- 6.24.4. Position

No special requirement.
- 6.24.5. Geometric visibility

No special requirement.
- 6.24.6. Orientation

No special requirement.
- 6.24.7. Electrical connections

No special requirement.

- 6.24.8. Tell-tale
No special requirement.
- 6.24.9. Other requirements
- 6.24.9.1. The exterior courtesy lamp shall not be switched ON unless the vehicle is stationary and one or more of the following conditions is satisfied:
- (a) The propulsion system is stopped; or
 - (b) A driver or passenger door is opened; or
 - (c) A load compartment door is opened.
- The provisions of paragraph 5.10. shall be met in all fixed positions of use.
- 6.24.9.2. Approved lamps emitting white light with the exception of main beam head lamps, day time running lamps and reversing lamps may be switched ON as courtesy lamp function. They may also be switched ON together with the exterior courtesy lamps and the condition of paragraphs 5.11. and 5.12. above may not apply.
- 6.24.9.3. The technical service shall, to the satisfaction of the Type Approval Authority, perform a visual test to verify that there is no direct visibility of the apparent surface of the exterior courtesy lamps, if viewed by an observer moving on the boundary of a zone on a transverse plane 10 m from the front of the vehicle, a transverse plane 10 m from the rear of the vehicle, and two longitudinal planes 10 m from each side of the vehicle; these four planes to extend from 1 m to 3 m above and perpendicular to the ground as shown in Annex 14.
- At the request of the applicant and with the consent of the Technical Service this requirement may be verified by a drawing or simulation.
- 6.25. Rear-end collision alert signal
- 6.25.1. Presence
Optional
The rear-end collision alert signal shall be given by the simultaneous operation of all the direction indicator lamps fitted as described in paragraph 6.25.7.
- 6.25.2. Number
As specified in paragraph 6.5.2.
- 6.25.3. Arrangement
As specified in paragraph 6.5.3.
- 6.25.4. Position
As specified in paragraph 6.5.4.
- 6.25.5. Geometric visibility
As specified in paragraph 6.5.5.
- 6.25.6. Orientation
As specified in paragraph 6.5.6.
- 6.25.7. Electrical connections. Compliance with these requirements shall be demonstrated by the applicant, by simulation or other means of verification accepted by the Technical Service responsible for type approval.
- 6.25.7.1. All the lamps of the rear-end collision alert signal shall flash in phase at a frequency of 4,0 +/- 1,0 Hz.

- 6.25.7.1.1. However, if any of the lamps of the rear end collision alert signal to the rear of the vehicle use filament light sources the frequency shall be 4,0 +0,0/-1,0 Hz.
- 6.25.7.2. The rear-end collision alert signal shall operate independently of other lamps.
- 6.25.7.3. The rear-end collision alert signal shall be switched ON and OFF automatically.
- 6.25.7.4. The rear-end collision alert signal shall not be switched ON if the direction indicator lamps, the hazard warning signal or the emergency stop signal is activated.
- 6.25.7.5. The rear-end collision alert signal may only be switched ON under the following conditions:

V_r	<i>switch ON</i>
$V_r > 30 \text{ km/h}$	$TTC \leq 1,4$
$V_r \leq 30 \text{ km/h}$	$TTC \leq 1,4 / 30 \times V_r$

" V_r (Relative Speed)": means the difference in speed between a vehicle with rear-end collision alert signal and a following vehicle in the same lane.

"TTC (Time to collision)": means the estimated time for a vehicle with rear-end collision alert signal and a following vehicle to collide assuming the relative speed at the time of estimation remains constant.

- 6.25.7.6. The switch ON period of the rear-end collision alert signal shall be not more than 3 seconds.
- 6.25.8. Tell-tale
Optional
- 6.26. Manoeuvring lamps (UN Regulation No. 23 or 148)
 - 6.26.1. Presence
Optional on motor vehicles.
 - 6.26.2. Number
One or two (one per side)
 - 6.26.3. Arrangement
No special requirement, however the requirements of paragraph 6.26.9. apply.
 - 6.26.4. Position
No special requirement.
 - 6.26.5. Geometric Visibility
No special requirement.
 - 6.26.6. Orientation
Downwards, however the requirements of paragraph 6.26.9. apply.
 - 6.26.7. Electrical Connections
Manoeuvring lamps shall be so connected that they cannot be switched ON unless the main-beam headlamps or the dipped-beam headlamps are switched ON at the same time.

The manoeuvring lamp(s) shall be switched ON automatically for slow manoeuvres up to 15 km/h provided that one of the following conditions is fulfilled:

- (a) Prior to the vehicle being set in motion for the first time after each manual activation of the propulsion system; or
- (b) Reverse gear is engaged; or
- (c) A camera based system which assists parking manoeuvres is operating.

The manoeuvring lamps shall be automatically switched OFF if the forward speed of the vehicle exceeds 15 km/h and they shall remain switched OFF until the switch ON conditions are met again.

6.26.8. Tell-tale

No special requirement.

6.26.9. Other requirements

6.26.9.1. The Technical Service shall, to the satisfaction of the Type Approval Authority, perform a visual test to verify that there is no direct visibility of the apparent surface of these lamps, if viewed by an observer moving on the boundary of a zone on a transverse plane 10 m from the front of the vehicle, a transverse plane 10 m from the rear of the vehicle, and two longitudinal planes 10 m from each side of the vehicle; these four planes to extend from 1 m to 3 m above and parallel to the ground as shown in Annex 14.

6.26.9.2. At the request of the applicant and with the consent of the Technical Service the requirement of 6.26.9.1 may be verified by a drawing or simulation or deemed to be satisfied if the installation conditions comply with paragraph 6.2.2. of UN Regulation No. 23 or paragraph 5.10.2. of UN Regulation No. 148, as noticed in the communication document in Annex 1, paragraph 9.

7. MODIFICATIONS AND EXTENSIONS OF APPROVAL OF THE VEHICLE TYPE OR OF THE INSTALLATION OF ITS LIGHTING AND LIGHT-SIGNALLING DEVICES

7.1. Every modification of the vehicle type, or of the installation of its lighting or light-signalling devices, or of the list referred to in paragraph 3.2.2. above, shall be notified to the Type Approval Authority which approved that vehicle type. The Authority may then either:

7.1.1. Consider that the modifications made are unlikely to have an appreciable adverse effect and that in any case the vehicle still meets the requirements; or

7.1.2. Require a further test report from the Technical Services responsible for conducting the tests.

7.2. Confirmation of extension or refusal of approval, specifying the alteration, shall be communicated by the procedure specified in paragraph 4.3. above to the Parties to the Agreement applying this Regulation.

7.3. The Type Approval Authority issuing the extension of approval shall assign a series number for such an extension and inform thereof the other Parties to the 1958 Agreement applying this Regulation by means of a communication form conforming to the model in Annex 1 to this Regulation.

8. CONFORMITY OF PRODUCTION

The conformity of production procedures shall comply with those set out in the Agreement, Appendix 2 (E/ECE/324-E/ECE/TRANS/505/Rev.2), with the following requirements:

8.1. Any vehicle approved pursuant to this Regulation shall be so manufactured as to conform to the type approved by meeting the requirements set out in paragraphs 5. and 6. above.

8.2. The holder of the approval shall in particular:

8.2.1. Ensure existence of procedures for effective quality control of the vehicle as regards all aspects relevant to compliance with the requirements set out in paragraphs 5. and 6. above;

8.2.2. Ensure that for each type of vehicle at least the tests prescribed in Annex 9 to this Regulation or physical checks from which equivalent data may be derived are carried out;

8.3. The Type Approval Authority may carry out any test prescribed in this Regulation. These tests will be on samples selected at random without causing distortion of the manufacturers delivery commitments.

8.4. The Type Approval Authority shall strive to obtain a frequency of inspection of once per year. However, this is at the discretion of the Type Approval Authority and their confidence in the arrangements for ensuring effective control of the conformity of production. In the case where negative results are recorded, the Type Approval Authority shall ensure that all necessary steps are taken to re-establish the conformity of production as rapidly as possible.

9. PENALTIES FOR NON-CONFORMITY OF PRODUCTION

9.1. The approval granted in respect of a type of vehicle pursuant to this Regulation may be withdrawn if the requirements are not complied with or if a vehicle bearing the approval mark does not conform to the type approved.

9.2. If a Party to the Agreement applying this Regulation withdraws an approval it has previously granted, it shall forthwith so notify the other Contracting Parties applying this Regulation by means of a communication form conforming to the model in Annex 1 to this Regulation.

10. PRODUCTION DEFINITELY DISCONTINUED

If the holder of the approval completely ceases to manufacture a type of vehicle approved in accordance with this Regulation, he shall inform the authority which granted the approval. Upon receiving the relevant communication, that authority shall inform thereof the other Parties to the Agreement applying this Regulation by means of a communication form conforming to the model in Annex 1 to this Regulation.

11. NAMES AND ADDRESSES OF TECHNICAL SERVICES RESPONSIBLE FOR CONDUCTING APPROVAL TESTS AND OF TYPE APPROVAL AUTHORITIES

The Contracting Parties to the 1958 Agreement applying this Regulation shall communicate to the United Nations Secretariat the names and addresses of the Technical Services responsible for conducting approval tests and of the Type Approval Authorities which grant approval and to which forms certifying approval or extension or refusal or withdrawal of approval, issued in other countries, are to be sent.

12. TRANSITIONAL PROVISIONS

12.1 General

12.1.1. As from the official date of entry into force of the most recent series of amendments, no Contracting Party applying this Regulation shall refuse to grant approval under this Regulation as amended by this most recent series of amendments.

12.1.2. As from the official date of entry into force of the most recent series of amendments, no Contracting Party applying this Regulation shall refuse national or regional type approval to a vehicle type approved under this Regulation as amended by this most recent series of amendments.

12.1.3. During the time period from the official date of entry into force of the most recent series of amendments and its mandatory application to new type approvals, Contracting Parties applying this Regulation shall continue to grant approvals to those types of vehicles which comply with the requirements of this Regulation as amended by all the applicable preceding series of amendments.

12.1.4. Existing approvals under this Regulation granted before the date of mandatory application of the most recent series of amendment shall remain valid indefinitely and Contracting Parties applying this Regulation shall continue to recognize them and shall not refuse to grant extensions of approvals to them (except for what indicated in paragraph 12.1.6. below).

12.1.5. When the vehicle type approved to any of the preceding series of amendments meets the requirements of this Regulation as amended by the most recent series of amendments, the Contracting Party which granted the approval shall notify the other Contracting Parties applying this Regulation thereof.

12.1.6. Notwithstanding paragraph 12.1.4. above, Contracting Parties whose application of this Regulation comes into force after the date of entry into force of the most recent series of amendments are not obliged to accept approvals which were granted in accordance with any of the preceding series of amendments to this Regulation.

12.1.7. Until the United Nations Secretary-General is notified otherwise, Japan declares that in relation to the installation of lighting and light signalling devices, Japan will only be bound by the obligations of the Agreement to which this Regulation is annexed with respect to vehicles of categories M₁ and N₁.

12.2. Transitional provisions applicable to 03 series of amendments.

Contracting Parties applying this Regulation:

(a) From 10 October 2007 (12 months after the date of entry into force), shall grant approvals only if the vehicle type to be approved meets the requirements of this Regulation as amended by the 03 series of amendments;

(b) Up to 09 October 2009 (36 months after the date of entry into force) shall not refuse national or regional type approval of a vehicle type approved to any of the preceding series of amendments to this Regulation.

(c) From 10 October 2009 (36 months after the entry into force) may refuse first national or regional entry into service of a vehicle of categories N₂ (with a maximum mass exceeding 7.5 tonnes), N₃, O₃ and O₄ exceeding 2 100 mm in width (for rear markings) and exceeding 6 000 mm in length (for side markings), except tractors for semi-trailers and incomplete vehicles, which do not meet the requirements of the 03 series of amendments to this Regulation.

- (d) Notwithstanding paragraph 12.1.4., from 10 October 2011 (60 months after the date of entry into force) shall no more recognize approvals to this Regulation granted to type of vehicles of categories N₂ (with a maximum mass exceeding 7.5 tons), N₃, O₃ and O₄ exceeding 2 100 mm in width (for rear markings) and exceeding 6 000 mm in length (for side markings), except tractors for semi-trailers and incomplete vehicle, under any preceding series of amendment, that ceases to be valid.
- (e) From 12 June 2010 (36 months from the entry into force of Supplement 3 to the 03 series of amendments) shall grant approvals only if the vehicle type to be approved meets the requirements of this Regulation as amended by Supplement 3 to the 03 series of amendments.
- (f) Up to 11 January 2010 (18 months after the official date of entry into force of Supplement 4 to the 03 series of amendments) shall continue to grant approvals to new vehicle types which do not meet the requirements on vertical orientation of front fog lamps (paragraph 6.3.6.1.1.) and/or on direction indicator operating tell-tale (paragraph 6.5.8.) and/or on daytime running lamps switching off (paragraph 6.19.7.3.).
- (g) Up to 10 October 2011 (60 month after the official date of entry into force) shall continue to grant approvals to new vehicle types which do not meet the requirements on cumulative length of conspicuity markings (paragraph 6.21.4.1.3.). ⁽¹⁸⁾

12.3. Transitional provisions applicable to 04 series of amendments.

Contracting Parties applying this Regulation:

- (a) From 07 February 2011 for vehicles of categories M₁ and N₁, and from 07 August 2012 for vehicles of other categories (respectively 30 and 48 months after the official date of entry into force) shall grant approvals only if the vehicle type to be approved meets the requirements of this Regulation as amended by the 04 series of amendments.
- (b) After 22 July 2009 (date of entry into force of Supplement 2 to the 04 series of amendments) shall continue to grant approvals to vehicle types which do not meet the requirements of paragraph 5.2.1. as amended by the Supplement 2 to 04 series of amendments if they are fitted with headlamps approved to Regulation No. 98 (prior to Supplement 9) or Regulation No. 112 (prior to Supplement 8).
- (c) From 24 October 2012 (36 months from the entry into force of Supplement 3 to the 04 series of amendments) shall grant approvals only if the vehicle type to be approved meets the requirements on voltage limitation of paragraphs 3.2.7. and 5.27 to 5.27.4. of this Regulation as amended by Supplement 3 to the 04 series of amendments.
- (d) Up to 07 February 2011 for vehicles of categories M₁ and N₁ and to 07 August 2012 for vehicles of other categories (respectively 30 and 48 months after the official date of entry into force of Supplement 2 to the 04 series of amendments) shall continue to grant approvals to new vehicle types which do not meet the requirements on switching OFF of daytime running lamps reciprocally incorporated with front direction indicator lamps (paragraph 6.19.7.6.).

12.3.1. Notwithstanding the transitional provisions above, Contracting Parties whose application of Regulation No. 112 comes into force after 07 August 2008 (date of entry into force of the 04 series of amendments to the present Regulation) are not obliged to accept approvals if the vehicle type to be approved does not meet the requirements of paragraph 6.1.2. and 6.2.2. of this Regulation as amended by the 04 series of amendments to this Regulation with regard to Regulation No. 112.

⁽¹⁸⁾ Note by the secretariat: for paragraph 6.21.4.1.3., please refer to the text of the 03 series of amendments as contained in document E/ECE/324/Rev.1/Add.47/Rev.6 - E/ECE/TRANS/505/Rev.1/Add.47/Rev.6

- 12.4. Transitional provisions applicable to 05 series of amendments.
Contracting Parties applying this Regulation:
- (a) From 30 January 2015 (48 months from the official date of entry into force) shall grant approvals only if the vehicle type to be approved meets the requirements of this Regulation as amended by the 05 series of amendments.
 - (b) Until 30 July 2016 for new vehicles types of categories M₁ and N₁ and until 30 January 2018 for new vehicle types of other categories (respectively 66 and 84 months after the official date of entry into force) shall grant approvals if the new vehicle type to be approved meets the requirements of one or more of paragraphs 6.2.7.6.2. or 6.2.7.6.3. to 6.2.7.6.3.3. instead of those of paragraph 6.2.7.6.1. of this Regulation as amended by the 05 series of amendments.
- 12.5. Transitional provisions applicable to 06 series of amendments.
Contracting Parties applying this Regulation:
From 18 November 2017 (60 month after the date of entry into force) shall grant approvals only if the vehicle type to be approved meets the requirements of this Regulation as amended by the 06 series of amendments.
- 12.6. Transitional provisions applicable to the 07 series of amendments
- 12.6.1. As from the official date of entry into force of the 07 series of amendments, no Contracting Party applying this Regulation shall refuse to grant or refuse to accept UN type approvals under this Regulation as amended by the 07 series of amendments.
 - 12.6.2. As of 6 July 2022, Contracting Parties applying this Regulation shall not be obliged to accept UN type approvals to the preceding series of amendments, first issued after 5 July 2022.
 - 12.6.3. Until 6 July 2024, Contracting Parties applying this Regulation shall accept UN type approvals to the preceding series of amendments and extensions thereof, first issued before 6 July 2022.
 - 12.6.4. As from 7 July 2024, Contracting Parties applying this Regulation shall not be obliged to accept UN type approvals, including any extensions, issued to the preceding series of amendments to this Regulation without emergency stop signal installed.
 - 12.6.5. Notwithstanding the transitional provisions above, Contracting Parties who start to apply this Regulation after the date of entry into force of the most recent series of amendments are not obliged to accept UN type approvals which were granted in accordance with any of the preceding series of amendments to this Regulation.
 - 12.6.6. Notwithstanding paragraph 12.6.4., Contracting Parties applying this Regulation shall continue to accept UN type approvals to the preceding series of amendments to this Regulation, for the vehicle types which are not affected by the changes introduced by the 07 series of amendments.
 - 12.6.7. Contracting Parties applying this Regulation shall not refuse to grant UN type approvals according to any preceding series of amendments to this Regulation or extensions thereof.
-

ANNEX 1

Communication

(maximum format: A4 (210 x 297 mm))



issued by: Name of administration
.....
.....
.....

concerning: (2)
Approval granted
Approval extended
Approval refused
Approval withdrawn
Production definitively discontinued

of a type of vehicle with regard to the installation of lighting and light- signalling devices, pursuant to Regulation No. 48.

Approval No.: Extension No.:

- 1. Trade name or mark of the vehicle:
2. Manufacturer's name for the type of vehicle:
3. Manufacturer's name and address:
4. If applicable, name and address of the manufacturer's representative:
5. Submitted for approval on:
6. Technical Service responsible for conducting approval tests:
7. Date of test report:
8. Number of test report:
9. Concise description:
Lighting and light-signalling devices on the vehicle:
9.1. Main-beam headlamps: yes/no2
9.2. Dipped-beam headlamps: yes/no2
9.3. Front-fog lamps: yes/no2
Comments: Reciprocally incorporated in headlamp: yes/no2
9.4. Reversing lamps: yes/no2
9.5. Front direction-indicators: yes/no2
9.6. Rear direction-indicators: yes/no2
9.7. Side direction-indicators: yes/no2
9.8. Hazard warning signal: yes/no2
9.9. Stop-lamps: yes/no2
9.9.1. Tell-tale indicating failure, as required by component regulation, fitted: yes/no2
9.10. Rear registration plate illuminating device: yes/no2
9.11. Front position lamps: yes/no2

9.11.1.	Tell-tale indicating failure, as required by component regulation, fitted:	yes/no ²	
9.12.	Rear position lamps:	yes/no ²	
9.12.1.	Tell-tale indicating failure, as required by component regulation, fitted:	yes/no ²	
9.13.	Rear fog-lamps:	yes/no ²	
9.14.	Parking lamps:	yes/ no ²	
9.15.	End-outline marker lamps:	yes/no ²	
9.15.1.	Tell-tale indicating failure, as required by component regulation, fitted:	yes/no ²	
9.16.	Rear retro-reflectors, non-triangular:	yes/no ²	
9.17.	Rear retro-reflectors, triangular:	yes/no ²	
9.18.	Front retro-reflectors, non-triangular:	yes/no ²	
9.19.	Side retro-reflectors, non-triangular:	yes/no ²	
9.20.	Side marker lamps:	yes/no ²	
9.21.	Daytime running lamps:	yes/no ²	
9.21.1.	Tell-tale indicating failure, as required by component regulation, fitted:	yes/no ²	
9.22.	Adaptive front lighting system (AFS): yes/no ²		
9.23.	Cornering lamps:	yes/no ²	
9.24.	Conspicuity markings:	Rear	Side
9.24.1.	Full contour markings:	yes/no ²	yes/no ²
9.24.2.	Partial contour markings:	yes/no ²	yes/no ²
9.24.3.	Line markings:	yes/no ²	yes/no ²
9.24.4.	Exemption regarding conspicuity marking according to paragraph 6.21.1.2.5.		
		Rear	
		yes/no ²	
		Comments:	
		Side	
		yes/no ²	
		Comments	
9.25.	Emergency stop signal:	yes/no ²	
9.26.	Manoeuvring lamps:	yes/no ²	
9.27.	Exterior courtesy lamps:	yes/no ²	
9.28.	Equivalent lamps:	yes/no ²	
9.29.	Maximum permissible load in the boot:		
9.30.	Lamps approved for and equipped with LED substitute light source(s) are allowed to be installed on this vehicle type: yes/no ² (?)		
10.	Comments:		

- 10.1. Any comments on movable components:
- 10.2. Method used for the definition of the apparent surface:
 - (a) Boundary of the illuminating surface² or
 - (b) Light-emitting surface²
- 10.3. Other comments (valid for right-hand or left-hand drive vehicles):
- 10.4. Comments concerning AFS (according to paragraphs 3.2.6. and 6.22.7.4. of this Regulation):
- 10.5. Comments regarding the extent of coverage of the conspicuity marking if it is less than the minimum value of 70 per cent required by paragraphs 6.21.4.1.2. and 6.21.4.2.2. of this Regulation.
- 10.6. For vehicles of M and N categories comments regarding the electrical supply conditions (according to paragraphs 3.2.7 and 5.27 of this Regulation)
- 10.7. Comments regarding conspicuity marking (according to paragraphs 6.21.1.2.5. and 6.21.4.3.1. of this Regulation)
- 10.8. Comments regarding conspicuity marking (Incomplete vehicle or Complete Vehicles according to paragraphs 6.21.1.2.1. and 6.21.1.2.2.1. of this Regulation):

Incomplete vehicles:	yes/no ²
Complete vehicles:	yes/no ²
Completed vehicles:	yes/no ²
- 11. Position of the approval mark:
- 12. Reason(s) for extension (if applicable):
- 13. Approval granted/extended/refused/withdrawn²
- 14. Place:
- 15. Date:
- 16. Signature:
- 17. The following documents, bearing the approval number shown above, are available on request:

(¹) Distinguishing number of the country which has granted/refused/withdrawn approval (see approval provisions in the Regulation).
 (²) Strike out what does not apply.
 (³) If yes, list the applicable lamps.



ANNEX 2

Arrangements of approval marks

Model A

(See paragraph 4.4. of this Regulation)



a = 8 mm min.

The above approval mark affixed to a vehicle shows that the vehicle type concerned has, with regard to the installation of lighting and light-signalling devices, been approved in the Netherlands (E 4) pursuant to UN Regulation No. 48 as amended by the 07 series of amendments. The approval number indicates that the approval was granted in accordance with the requirements of UN Regulation No. 48 as amended by the 07 series of amendments.

Model B

(See paragraph 4.5. of this Regulation)

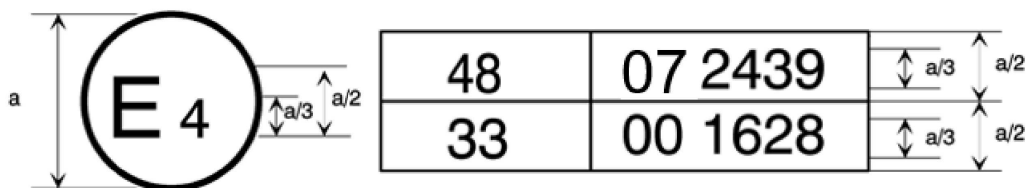

a = 8 mm min.

The above approval mark affixed to a vehicle shows that the vehicle type concerned has been approved in the Netherlands (E 4) pursuant to UN Regulation No. 48 as amended by the 07 series of amendments and UN Regulation No. 33. (1) The approval number indicates that, at the dates when the respective approvals were given, UN Regulation No. 48 was amended by the 07 series of amendments and UN Regulation No. 33 was still in its original form.

(1) The second number is given merely as an example.

ANNEX 3

Examples of lamp surfaces, axes, centres of reference, and angles of geometric visibility

These examples show some arrangements to aid the understanding of the provisions and are not intended to be design restrictive .

KEY for all examples in this Annex:

1. Illuminating surface	IO Inner optical part
2. Axis of reference	LG Light guide
3. Centre of reference	L Outer lens
4. Angle of geometric visibility	R Reflector
5. Light-emitting surface	S Light source
6. Apparent surface based on the illuminating surface	X Not part of this function
7a. Apparent surface based on the light-emitting surface according to paragraph 2.10.2. (a) (with outer lens)	F1 Function one
7b. Apparent surface based on the light-emitting surface according to paragraph 2.10.2. (b) (without outer lens)	F2 Function two
8. Direction of visibility	

Part 1

Light emitting surface of a light-signalling device other than a retro-reflector

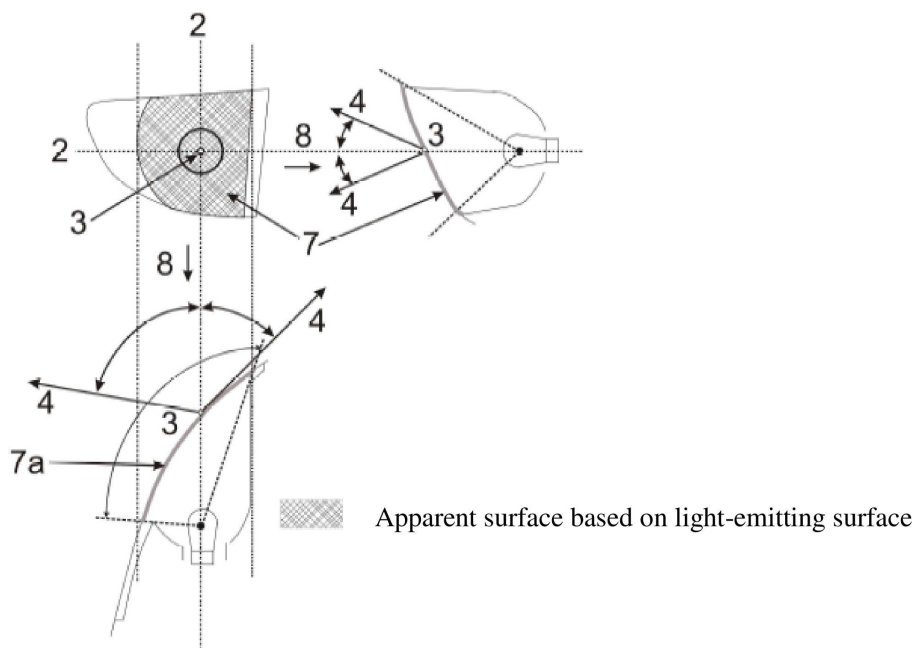

Part 2

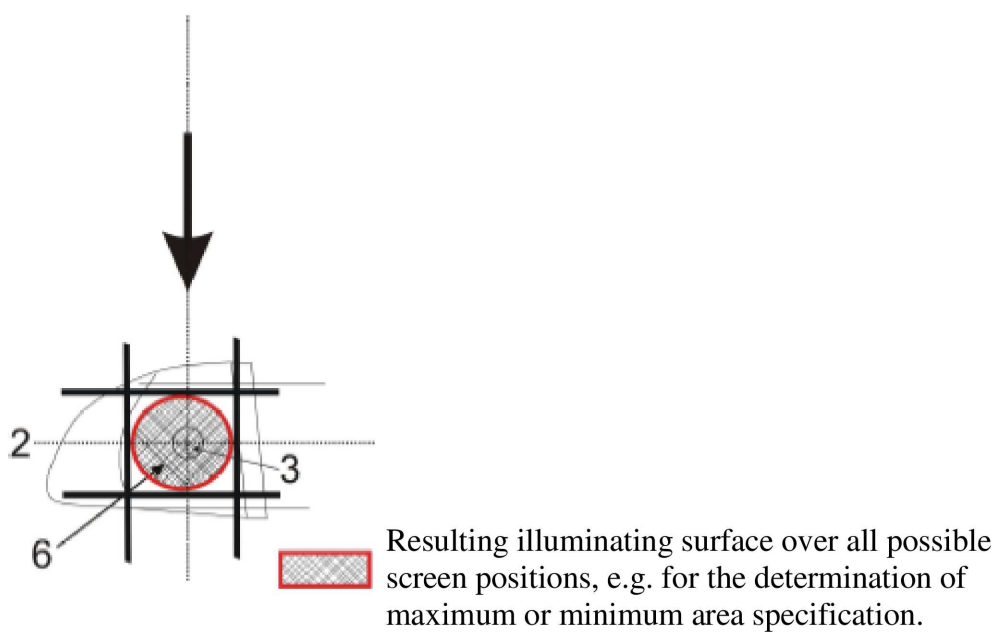
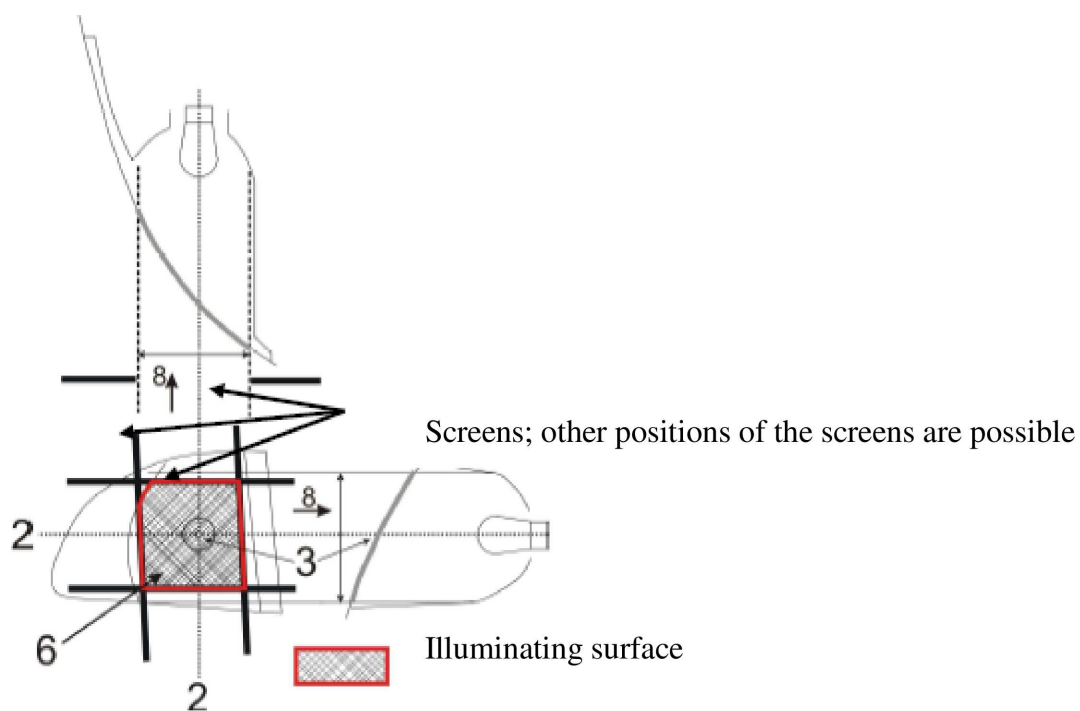
Illuminating surface of a light-signalling device other than a retro-reflector

Part 3

Examples of apparent surface based on illuminating surface in different directions of geometric visibility

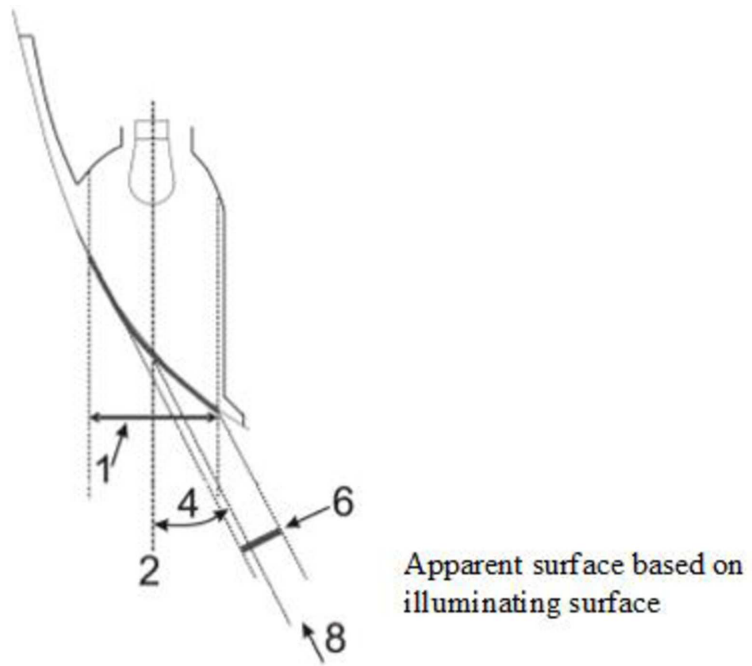
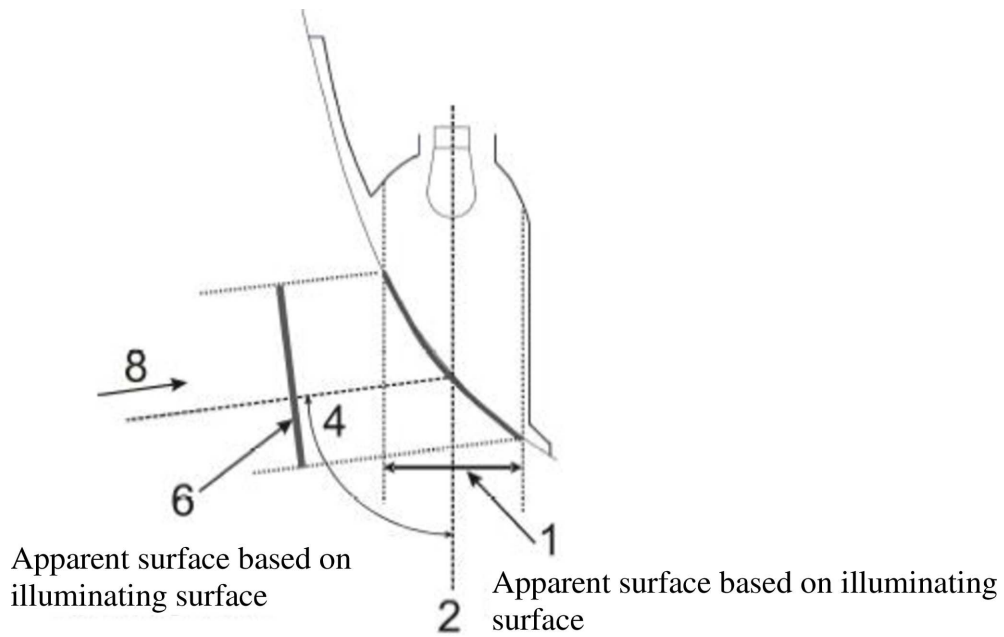

Part 4

Examples of apparent surface based on light emitting surface in different directions of geometric visibility

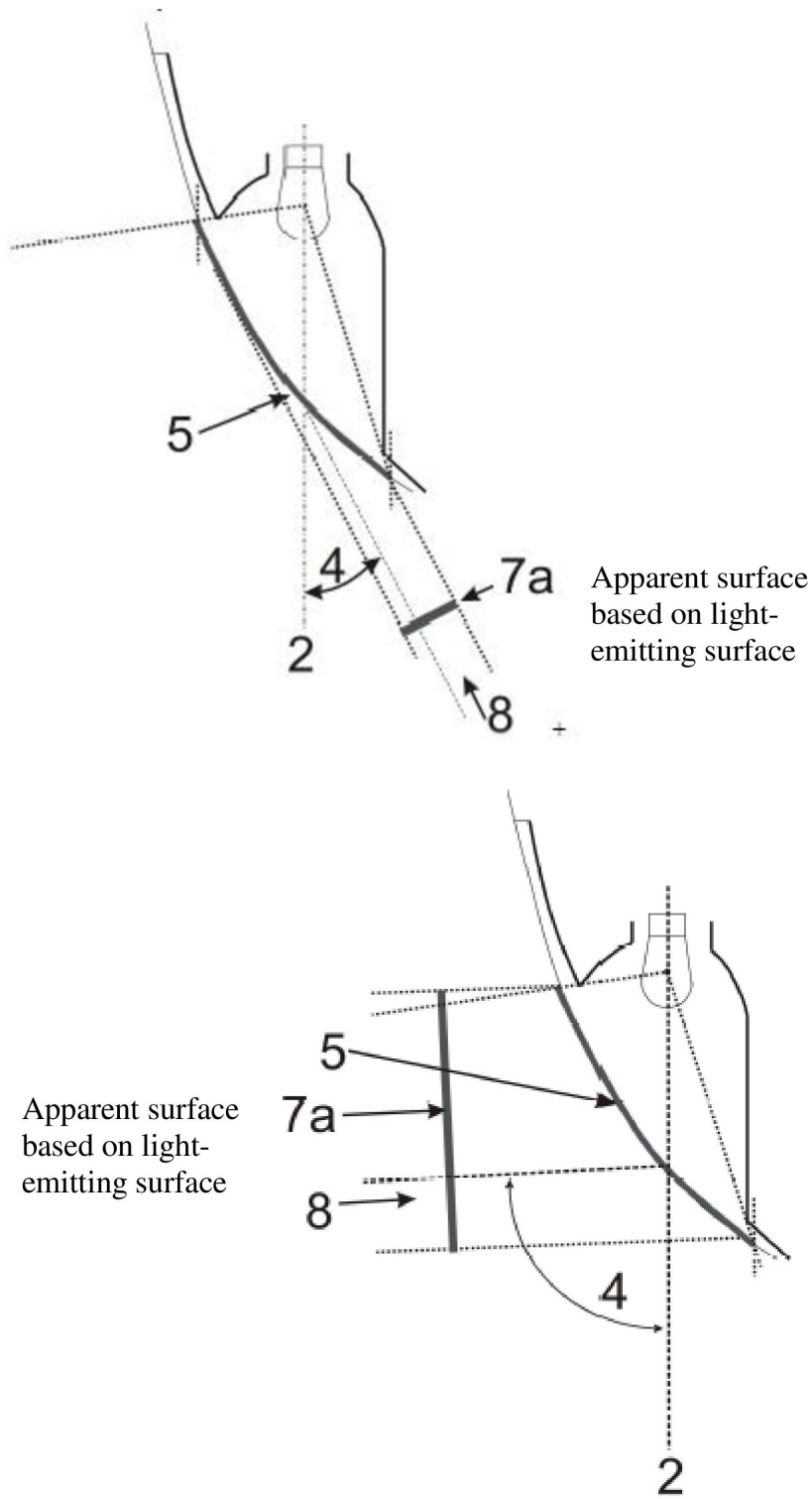

Part 5

Example of illuminating surface in comparison with light-emitting surface in the case of a "single function lamp"

(see paragraphs 2.10.2. to 2.10.3. of this Regulation)

Examples of a light source with a reflector optic behind an outer lens:

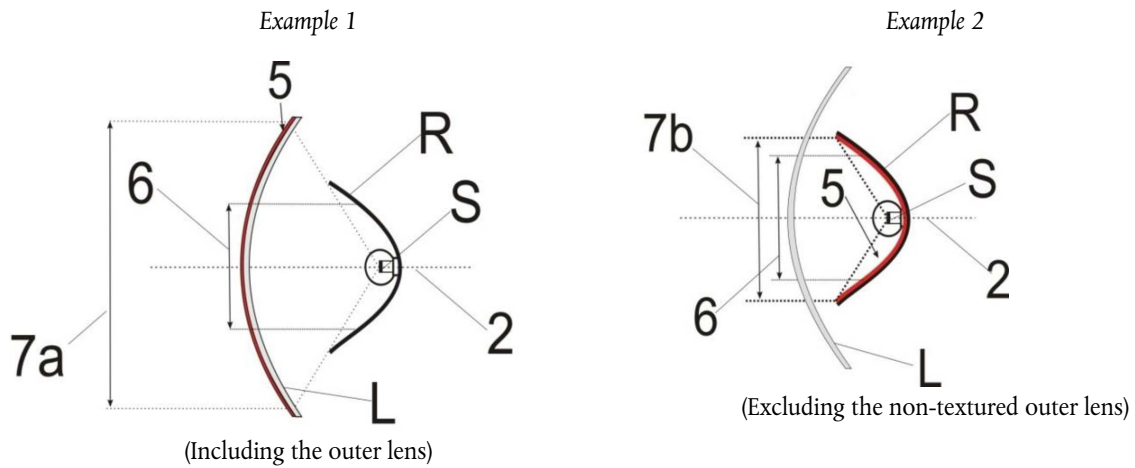

Examples of a light source with a reflector optic with a inner lens behind an outer lens:

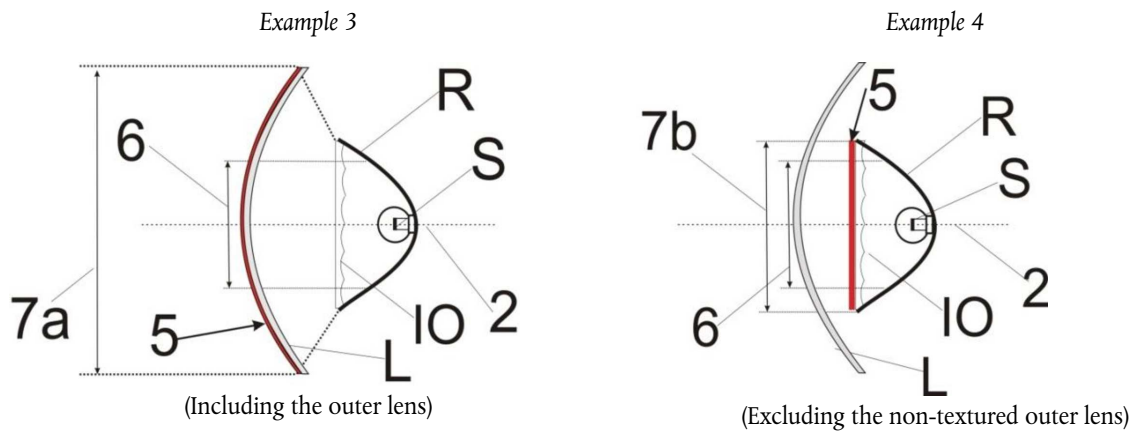

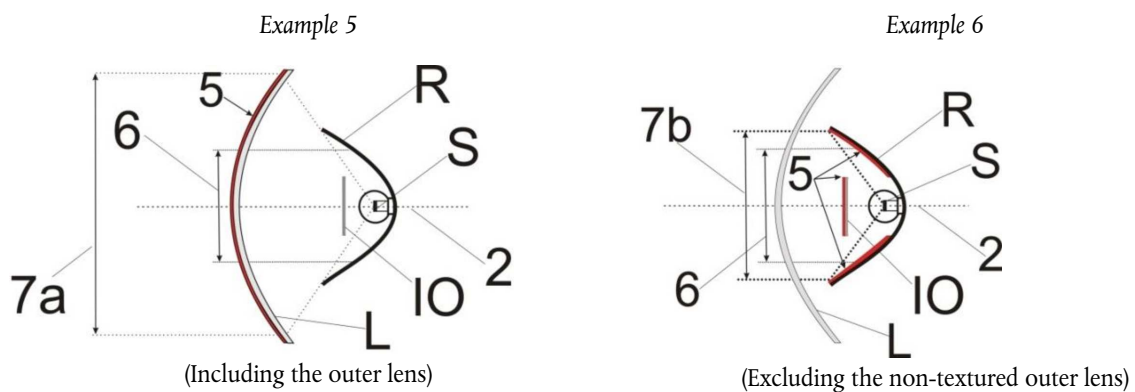

Examples of a light source with a reflector optic with a partial inner lens behind an outer lens:

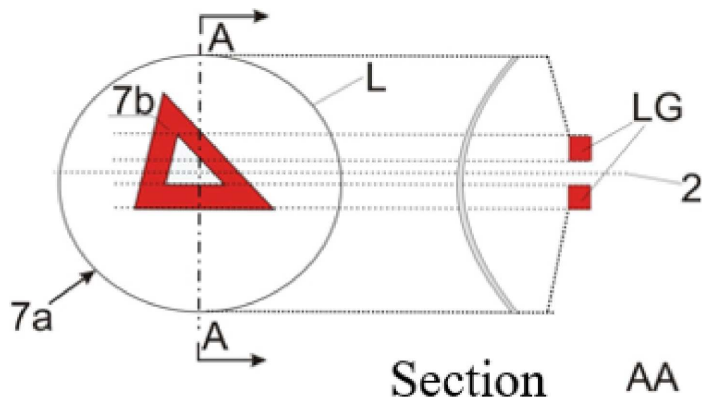

Example of a light guide optic behind an outer lens:

Example 7



 In the case where the non-textured outer lens is excluded, "7b" is the apparent surface according to paragraph 2.10.2. (b).

Example of a light guide optic or a reflector optic behind an outer lens:

Example 8

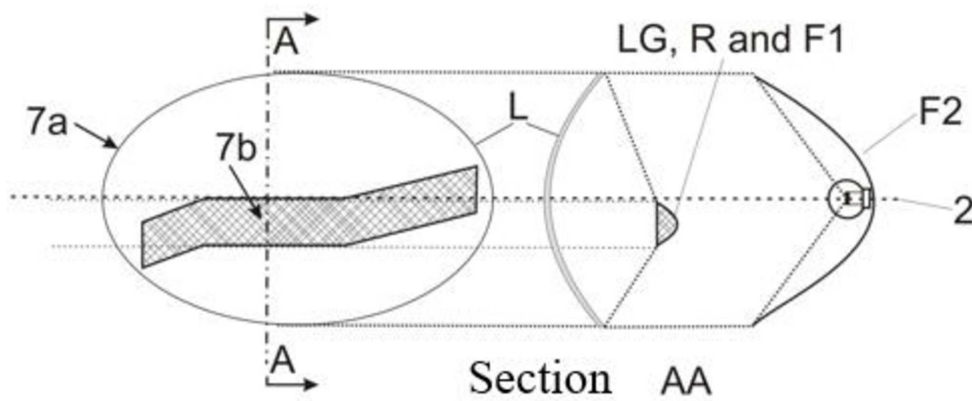

 In the case where the non textured outer lens is excluded, "7b" is the apparent surface according to paragraph 2.10.2. (b), and F1 shall not transparent to F2

Example of a light source with a reflector optic in combination with an area which is not part of this function, behind an outer lens:

Example 9

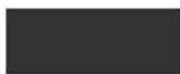
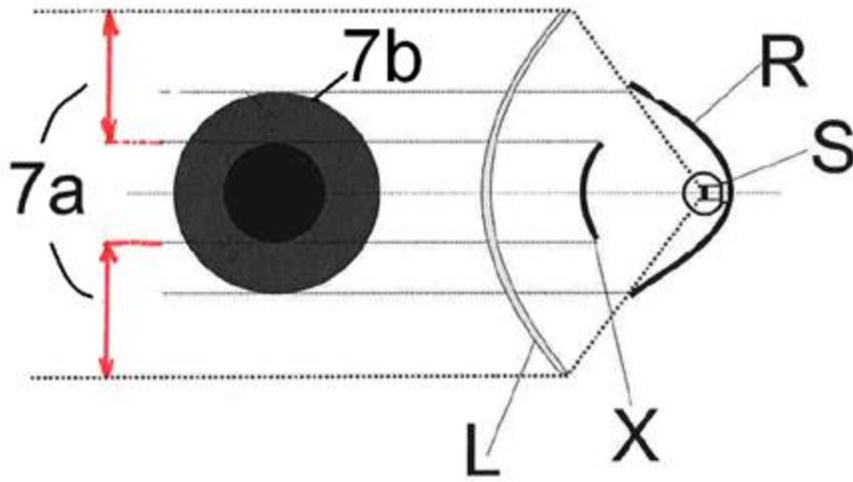

In the case where the non textured outer lens is excluded, "7b" is the apparent surface according to paragraph 2.10.2. (b).

Part 6

Examples showing the determination of the light-emitting surface in comparison with illuminating surface

(See paragraphs 2.10.2. and 2.10.3. of this Regulation)

Note: Reflected light could / may contribute to the determination of the light emitting surface

Example A

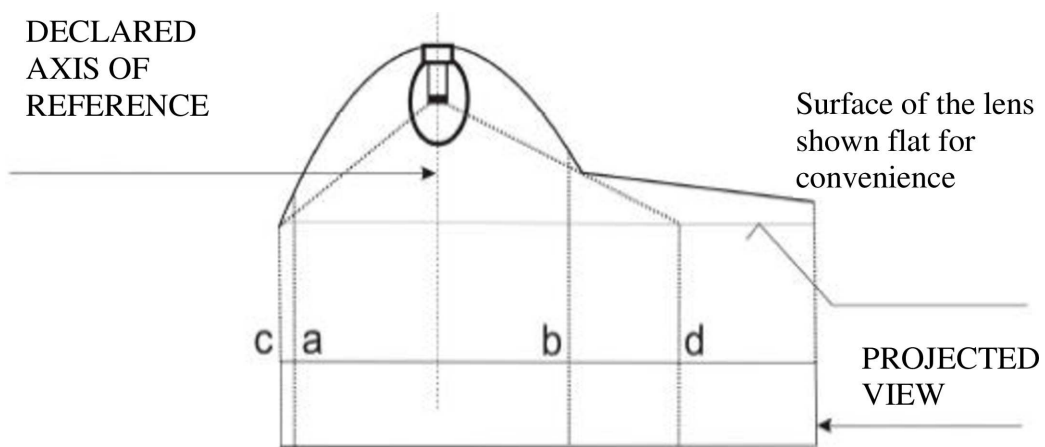

	Illuminating surface	Declared light-emitting surface according to 2.10.2. (a)
Edges are	a and b	c and d

Example B

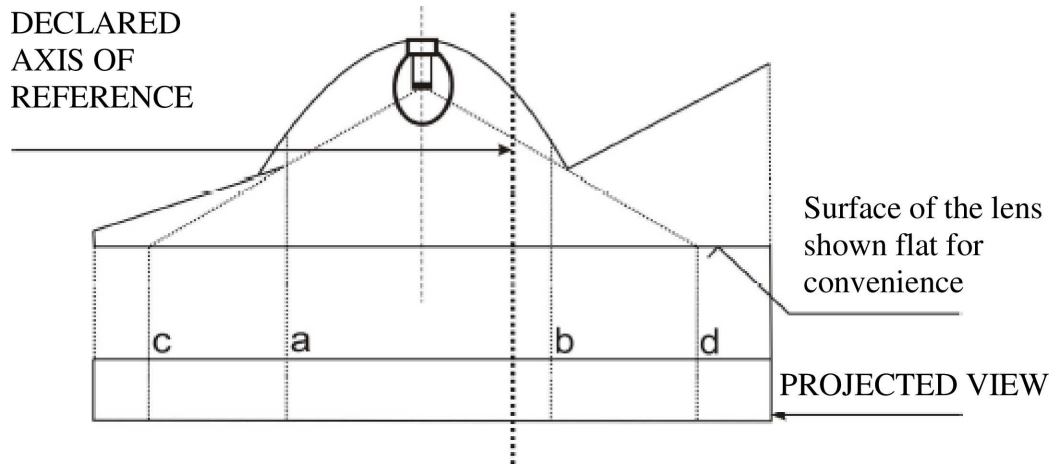

	Illuminating surface	Declared light-emitting surface according to 2.10.2. (a)
Edges are	a and b	c and d

Example to determine the illuminating surface in combination with an area which is not part of the function:

Example C

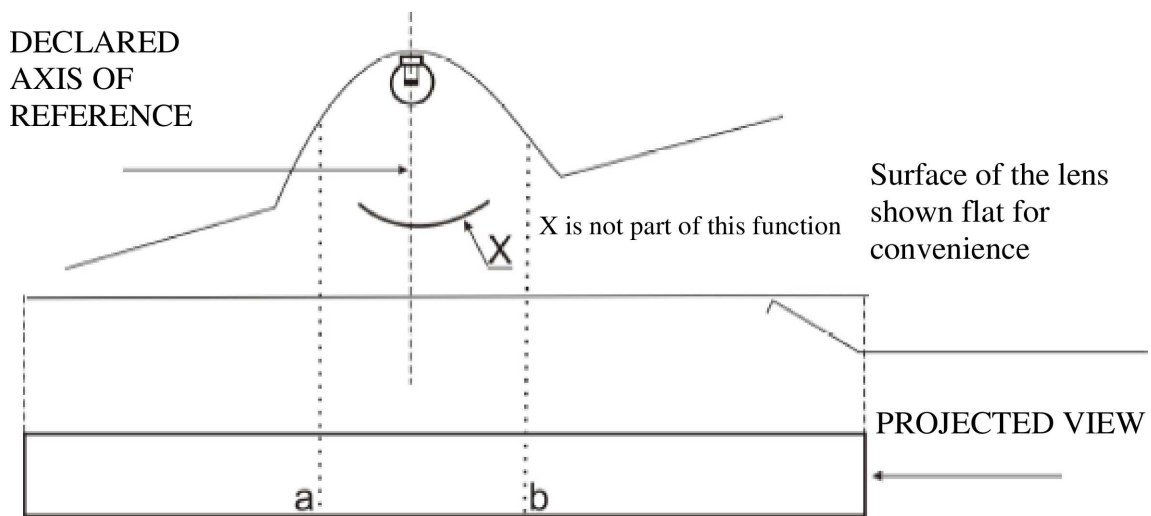

	Illuminating surface
Edges are	a and b

Example to determine a light emitting surface according to 2.10.2. (a) in combination with an area which is not part of the function:

Example D

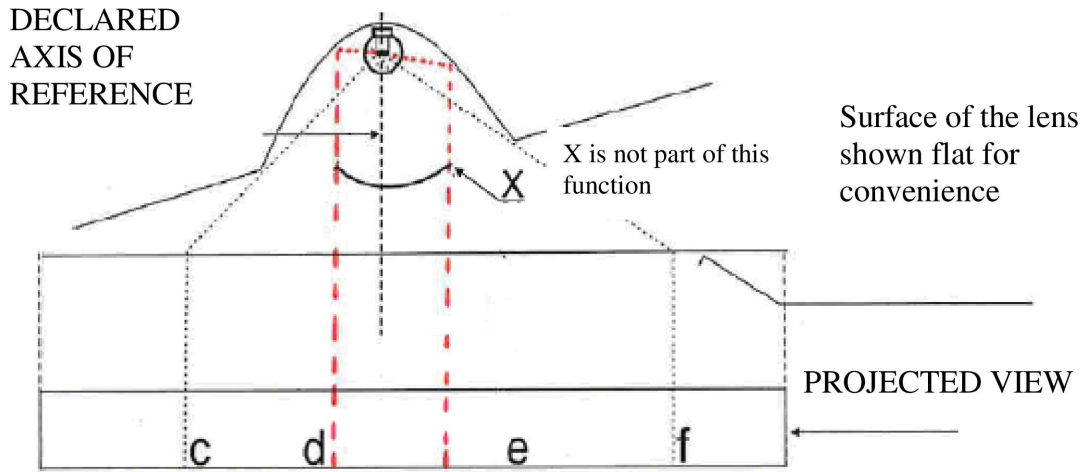

	Declared Light-emitting surface according to 2.10.2. (a)
Edges are	c-d and e-f

Example to determine the apparent surface in combination with an area which is not part of the function and a non-textured outer lens (according to 2.10.2. (b)):

Example E

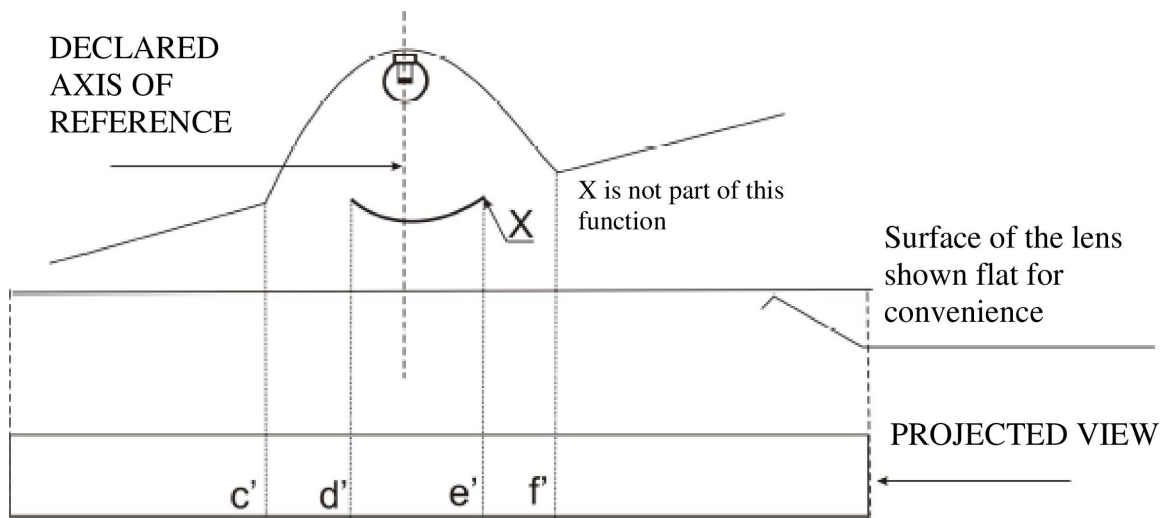

	Declared Light emitting surface according to 2.10.2. (b) for example
Edges are	c'-d' and e'-f'

Part 7

Examples to enable a decision regarding the reciprocal incorporation of two functions

In the case with a textured outer lens and a wall in between:

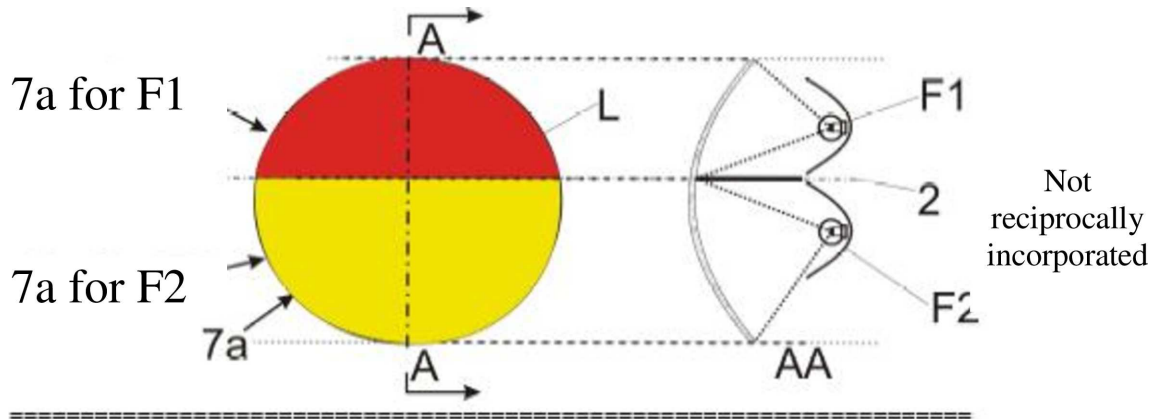

In the case with a textured outer lens:

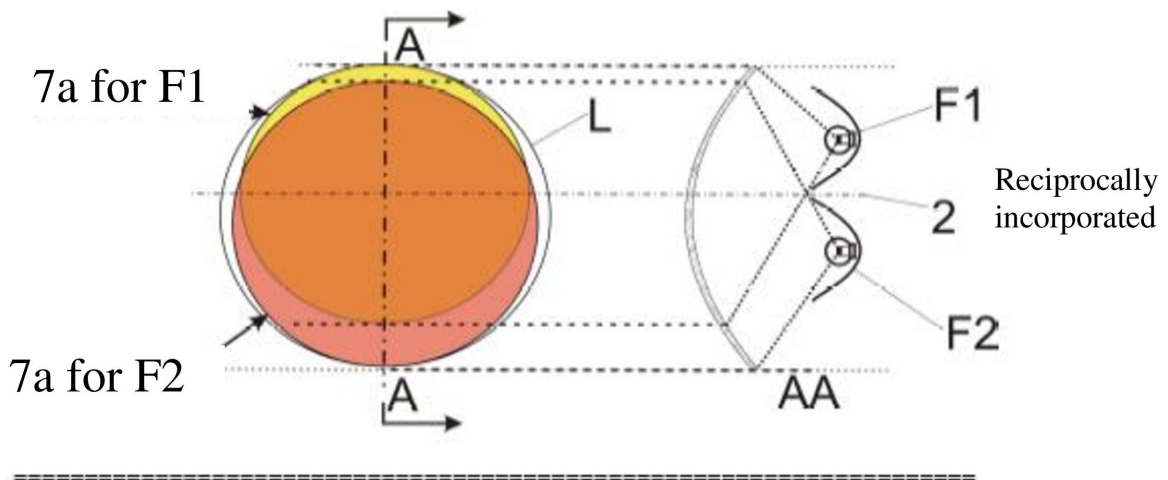

In the case where the non-textured outer lens is excluded:

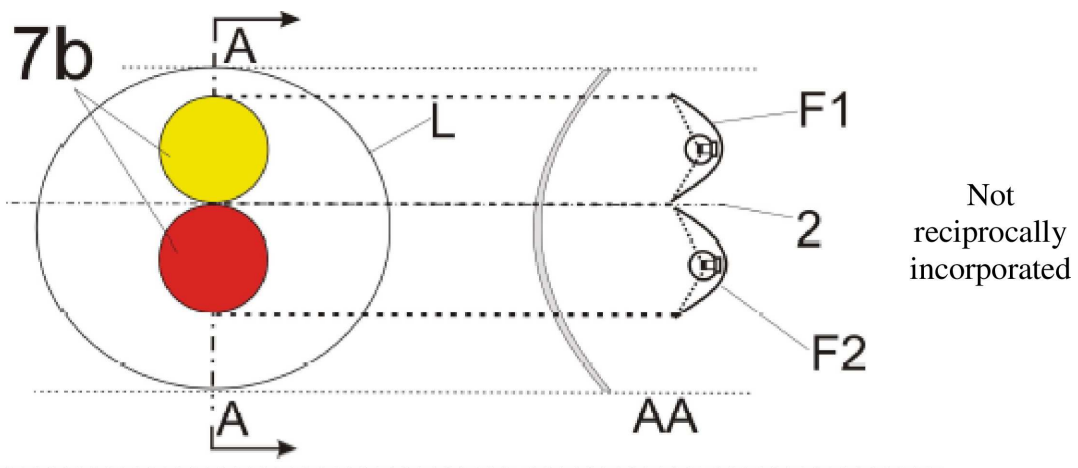

In the case where the non-textured outer lens is excluded:

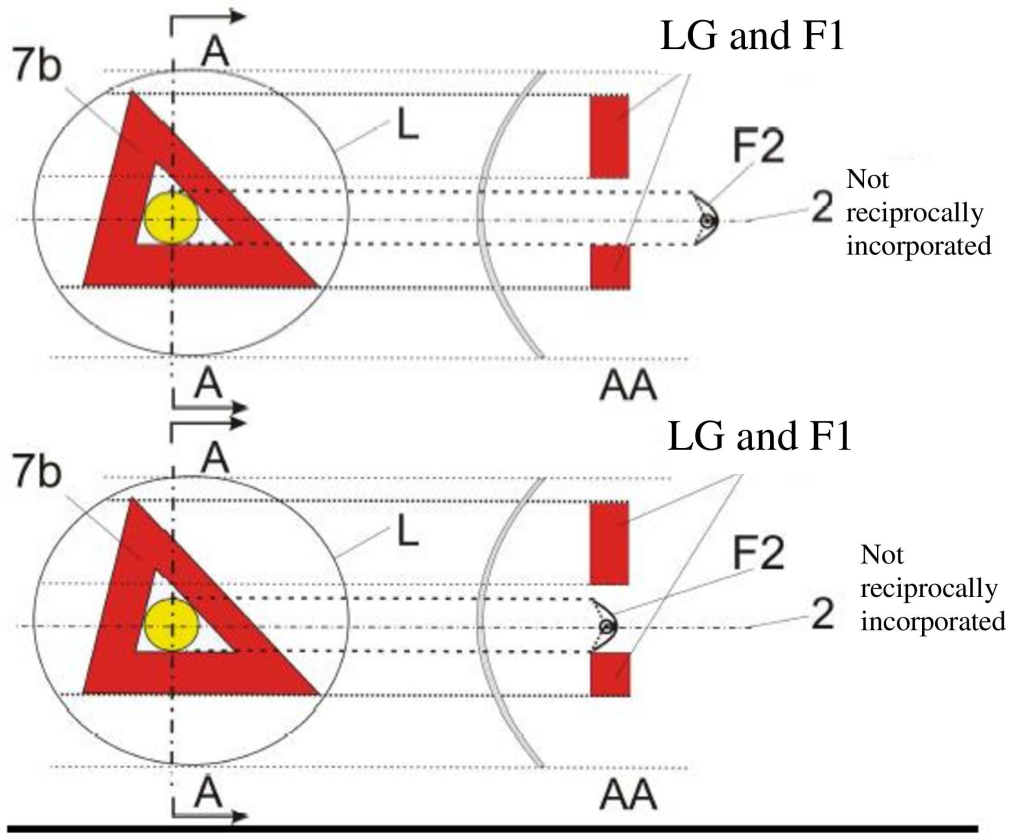

In the case where the outer lens (textured or not) is included:

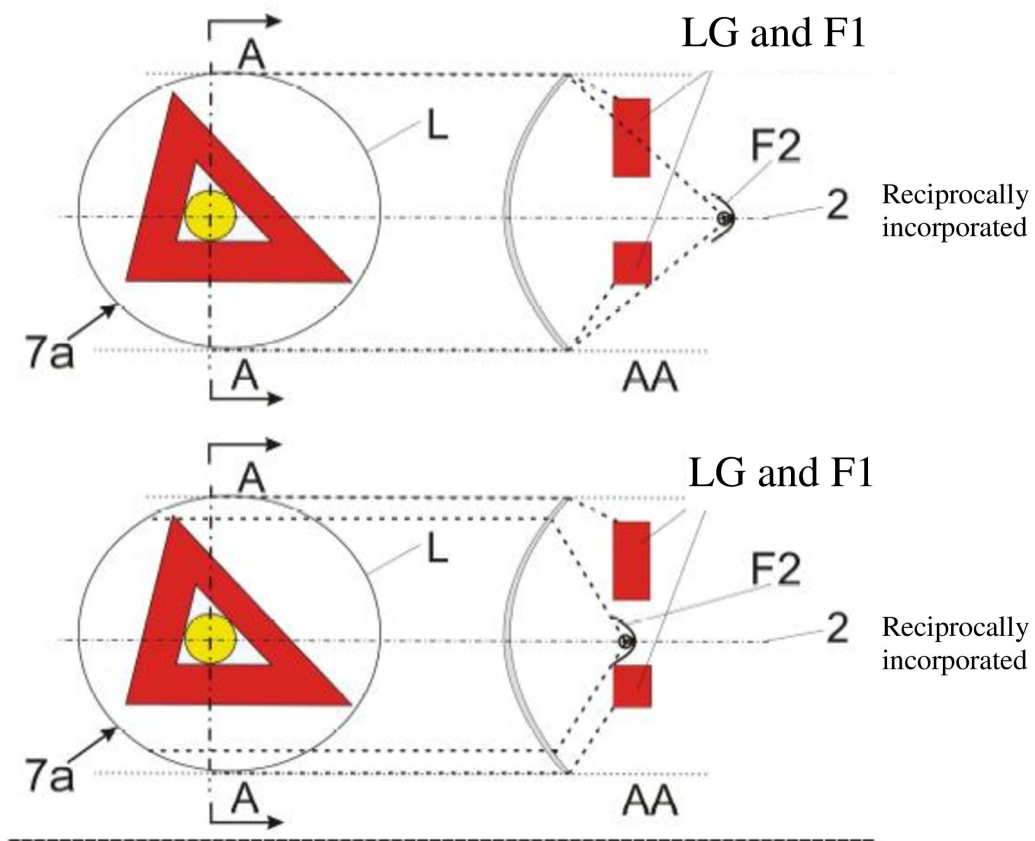

In the case where the outer lens (textured or not) is included:

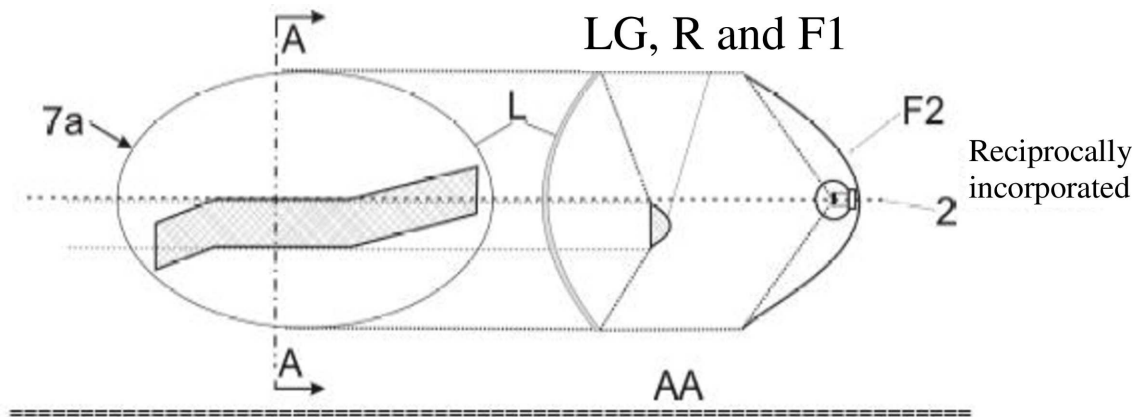

In the case where the non-textured outer lens is excluded, "7b" is the apparent surface according to paragraph 2.10.2. and F1 shall not be transparent to F2:

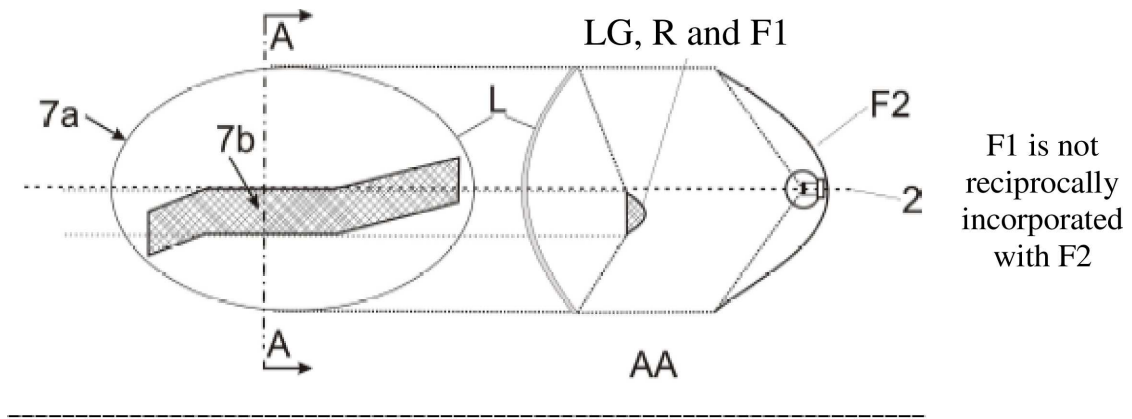

In the case where the non-textured outer lens is excluded or not:

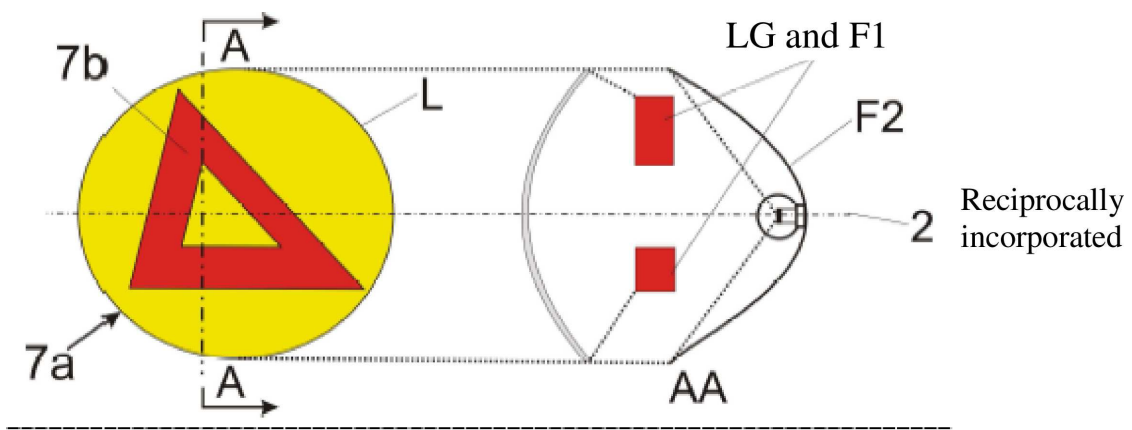

ANNEX 4

Visibility of a red lamp to the front and visibility of a white lamp to the rear

(See paragraphs 5.10.1. and 5.10.2. of this Regulation)

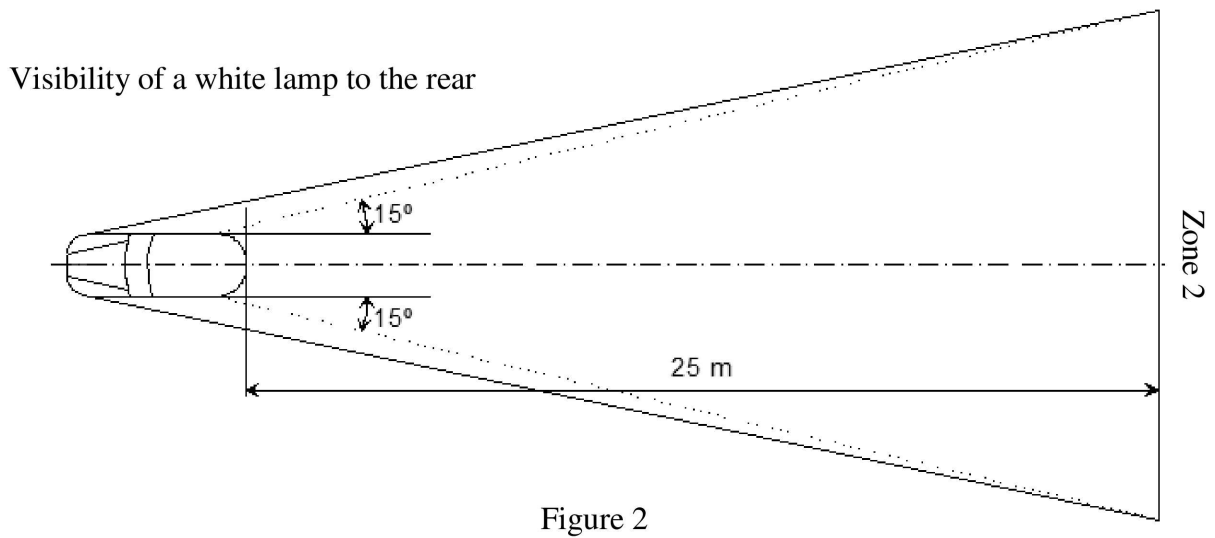
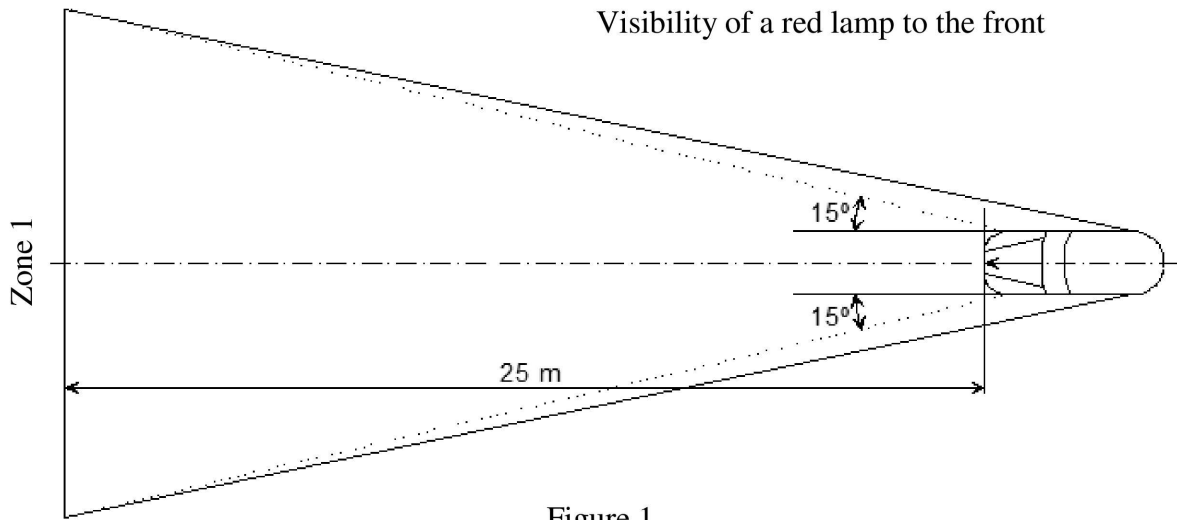

ANNEX 5

States of loading to be taken into consideration in determining variations in the vertical orientation of the dipped-beam headlamps

Loading conditions on axles referred to in paragraphs 6.2.6.1. and 6.2.6.3.1.

1. For the following tests, the mass of the passengers shall be calculated on the basis of 75 kg per person.
2. Loading conditions for different types of vehicles:
 - 2.1. Vehicles in category M₁: ⁽¹⁾
 - 2.1.1. The angle of the light beam of the dipped-beam headlamps shall be determined under the following load conditions:
 - 2.1.1.1. One person in the driver's seat;
 - 2.1.1.2. The driver, plus one passenger in the front seat farthest from the driver;
 - 2.1.1.3. The driver, one passenger in the front seat farthest from the driver, all the seats farthest to the rear occupied;
 - 2.1.1.4. All the seats occupied;
 - 2.1.1.5. All the seats occupied, plus an evenly distributed load in the luggage boot, in order to obtain the permissible load on the rear axle or on the front axle if the boot is at the front. If the vehicle has a front and a rear boot, the additional load shall be appropriately distributed in order to obtain the permissible axle loads. However, if the maximum permissible laden mass is obtained before the permissible load on one of the axles, the loading of the boot(s) shall be limited to the figure which enables that mass to be reached;
 - 2.1.1.6. Driver, plus an evenly distributed load in the boot, in order to obtain the permissible load on the corresponding axle.

However, if the maximum permissible laden mass is obtained before the permissible load on the axle, the loading of the boot(s) shall be limited to the figure which enables that mass to be reached.
 - 2.1.2. In determining the above loading conditions, account shall be taken of any loading restrictions laid down by the manufacturer.
 - 2.2. Vehicles in categories M₂ and M₃¹;

The angle of the light beam from the dipped-beam headlamps shall be determined under the following loading conditions:

 - 2.2.1. Vehicle unladen and one person in the driver's seat;
 - 2.2.2. Vehicles laden such that each axle carries its maximum technically permissible load or until the maximum permissible mass of the vehicle is attained by loading the front and rear axles proportionally to their maximum technically permissible loads, whichever occurs first.

⁽¹⁾ As defined in the Consolidated Resolution on the Construction of Vehicles (R.E.3.), document ECE/TRANS/WP.29/78/Rev.6, para. 2 - www.unece.org/trans/main/wp29/wp29wgs/wp29gen/wp29resolutions.html

2.3. Vehicles in category N with load surfaces:

2.3.1. The angle of the light beam from the dipped-beam headlamps shall be determined under the following loading conditions;

2.3.1.1. Vehicle unladen and one person in the driver's seat;

2.3.1.2. Driver, plus a load so distributed as to give the maximum technically permissible load on the rear axle or axles, or the maximum permissible mass of the vehicle, whichever occurs first, without exceeding a front axle load calculated as the sum of the front axle load of the unladen vehicle plus 25 per cent of the maximum permissible payload on the front axle. Conversely, the front axle is so considered when the load platform is at the front.

2.4. Vehicles in category N without a load surface:

2.4.1. Drawing vehicles for semi-trailers:

2.4.1.1. Unladen vehicle without a load on the coupling attachment and one person in the driver's seat;

2.4.1.2. One person in the driver's seat: technically permissible load on the coupling attachment in the position of the attachment corresponding to the highest load on the rear axle.

2.4.2. Drawing vehicles for trailers:

2.4.2.1. Vehicle unladen and one person in the driver's seat;

2.4.2.2. One person in the driver's seat, all the other places in the driving cabin being occupied.

ANNEX 6

Measurement of the variation of dipped-beam inclination as a function of load

1. SCOPE

This annex specifies a method for measuring variations in motor vehicle dipped-beam inclination, in relation to its initial inclination, caused by changes in vehicle attitude due to loading.

2. DEFINITIONS

2.1. Initial inclination

2.1.1. Stated initial inclination

The value of the dipped-beam initial inclination specified by the motor vehicle manufacturer serving as a reference value for the calculation of permissible variations.

2.1.2. Measured initial inclination

The mean value of dipped-beam inclination or vehicle inclination measured with the vehicle in condition No. 1, as defined in Annex 5, for the category of vehicle under test. It serves as a reference value for the assessment of variations in beam inclination as the load varies.

2.2. Dipped-beam inclination

It may be defined as follows:

Either as the angle, expressed in milliradians, between the direction of the beam towards a characteristic point on the horizontal part of the cut-off in the luminous distribution of the headlamp and the horizontal plane,

Or by the tangent of that angle, expressed in percentage inclination, since the angles are small (for these small angles, 1 per cent is equal to 10 mrad).

If the inclination is expressed in percentage inclination, it can be calculated by means of the following formula:

$$\frac{(h_1 - h_2)}{L} \times 100$$

where:

- h_1 is the height above the ground, in millimetres, of the above-mentioned characteristic point, measured on a vertical screen perpendicular to the vehicle longitudinal median plane, placed at a horizontal distance L .
- h_2 is the height above the ground, in millimetres, of the centre of reference (which is taken to be the nominal origin of the characteristic point chosen in h_1):
- L is the distance, in millimetres, from the screen to the centre of reference.

Negative values denote downward inclination (see Figure 1).

Positive values denote upward inclination.

Figure 1

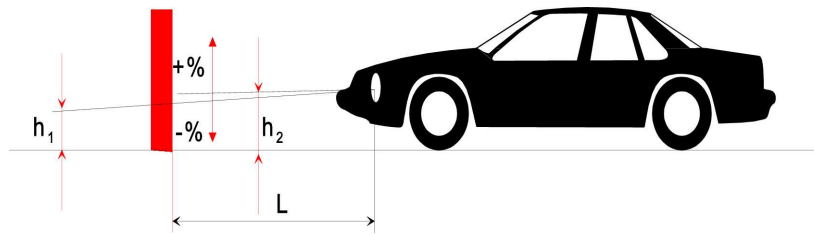
Dipped-beam downward inclination of a category M1 vehicle*Notes:*

1. This drawing represents a category M₁ vehicle, but the principle shown applies equally to vehicles of other categories.
2. Where the vehicle does not incorporate a headlamp levelling system, the variation in dipped-beam inclination is identical with the variation in the inclination of the vehicle itself.
3. MEASUREMENT CONDITIONS
 - 3.1. If a visual inspection of the dipped-beam pattern on the screen or a photometric method is used, measurement shall be carried out in a dark environment (for example, a dark room) of sufficient area to allow the vehicle and the screen to be placed as shown in Figure 1. Headlamp centres of reference shall be at a distance from the screen of at least 10 m.
 - 3.2. The ground on which measurements are made shall be as flat and horizontal as possible, so that the reproducibility of measurements of dipped-beam inclination can be assured with an accuracy of $\pm 0,5$ mrad ($\pm 0,05$ per cent inclination).
 - 3.3. If a screen is used, its marking, position and orientation in relation to the ground and to the median longitudinal plane of the vehicle, shall be such that the reproducibility of the measurement of the dipped-beam inclination can be assured with an accuracy of $\pm 0,5$ mrad ($\pm 0,05$ per cent inclination).
 - 3.4. During measurements, the ambient temperature shall be between 10 and 30 °C.
4. VEHICLE PREPARATION
 - 4.1. Measurements shall be carried out on a vehicle which has travelled a distance of between 1 000 km and 10 000 km, preferably 5 000 km.
 - 4.2. Tyres shall be inflated to the full-load pressure specified by the vehicle manufacturer. The vehicle shall be fully replenished (fuel, water, oil) and equipped with all the accessories and tools specified by the manufacturer. Full fuel replenishment means that the fuel tank shall be filled to not less than 90 per cent of its capacity.
 - 4.3. The vehicle shall have the parking brake released and the gearbox in neutral.
 - 4.4. The vehicle shall be conditioned for at least 8 h at the temperature specified in paragraph 3.4. above.
 - 4.5. If a photometric or visual method is used, headlamps with a well-defined dipped-beam cut-off should preferably be installed on the vehicle under test in order to facilitate the measurements. Other means are allowed to obtain a more precise reading (for example, removal of the headlamp lens).

5. TEST PROCEDURE

5.1. General

The variations in either dipped-beam or vehicle inclination, depending on the method chosen, shall be measured separately for each side of the vehicle. The results obtained from both left and right headlamps under all the load conditions specified in Annex 5, shall be within the limits set out in paragraph 5.5. below. The load shall be applied gradually without subjecting the vehicle to excessive shocks.

5.1.1. Where an AFS is fitted, the measurements shall be carried out with the AFS in its neutral state.

5.2. Determination of the measured initial inclination

The vehicle shall be prepared as specified in paragraph 4. above and laden as specified in Annex 5 (first loading condition of the respective vehicle category). Before each measurement, the vehicle shall be rocked as specified in paragraph 5.4. below. Measurements shall be made three times.

5.2.1. If none of the three measured results differ by more than 2 mrad (0,2 per cent inclination) from the arithmetic mean of the results, that mean shall constitute the final result.

5.2.2. If any measurement differs from the arithmetic mean of the results by more than 2 mrad (0,2 per cent inclination), a further series of 10 measurements shall be made, the arithmetic mean of which shall constitute the final result.

5.3. Measurement methods

Any method may be used to measure variations of inclination provided that the readings are accurate to within $\pm 0,2$ mrad ($\pm 0,02$ per cent inclination).

5.4. Treatment of vehicle in each loading condition

The vehicle suspension and any other part likely to affect dipped-beam inclination shall be activated according to the methods described below.

However, the technical authorities and manufacturers may jointly propose other methods (either experimental or based upon calculations), especially when the test poses particular problems, provided such calculations are clearly valid.

5.4.1. M_1 category vehicles with conventional suspension

With the vehicle standing on the measuring site and, if necessary, with the wheels resting on floating platforms (which shall be used if their absence would lead to restriction of the suspension movement likely to affect the results of measurements), rock the vehicle continuously for at least three complete cycles, for each cycle, first the rear and then the front end of the vehicle is pushed down.

The rocking sequence shall end with the completion of a cycle. Before making the measurements, the vehicle shall be allowed to come to rest spontaneously. Instead of using floating platforms, the same effect can be achieved by moving the vehicle backwards and forwards for at least a complete wheel revolution.

5.4.2. M_2 , M_3 and N category vehicles with conventional suspension

5.4.2.1. If the treatment method for category M_1 vehicles described in paragraph 5.4.1. is not possible, the method described in paragraphs 5.4.2.2. or 5.4.2.3. may be used.

5.4.2.2. With the vehicle standing on the measuring site and the wheels on the ground, rock the vehicle by temporarily varying the load.

5.4.2.3. With the vehicle standing on the measuring site and the wheels on the ground, activate the vehicle suspension and all other parts which may affect the dipped-beam inclination by using a vibration rig. This can be a vibrating platform on which the wheels rest.

- 5.4.3. Vehicles with non-conventional suspension, where the propulsion system has to be running.
Before making any measurement wait until the vehicle has assumed its final attitude with the engine running.
- 5.5. Measurements
- The variation of the inclination of the dipped-beam shall be assessed for each of the different loading conditions in relation to the measured initial inclination determined in accordance with paragraph 5.2. above.
- If the vehicle is fitted with a manual headlamp-levelling system, the latter shall be adjusted to the positions specified by the manufacturer for given loading conditions (according to Annex 5).
- 5.5.1. To begin with, a single measurement shall be made in each loading condition. Requirements have been met if, for all the loading conditions, the variation in inclination is within the calculated limits (for example, within the difference between the stated initial inclination and the lower and upper limits specified for approval) with a safety margin of 4 mrad (0,4 per cent inclination).
- 5.5.2. If the result(s) of any measurement(s) does (do) not lie within the safety margin indicated in paragraph 5.5.1. or exceed(s) the limit values, a further three measurements shall be made in the loading conditions corresponding to this (these) result(s) as specified in paragraph 5.5.3.
- 5.5.3. For each of the above loading conditions:
- 5.5.3.1. If none of the three measured results differs by more than 2 mrad (0,2 per cent inclination) from the arithmetic mean of the results, that mean shall constitute the final result.
- 5.5.3.2. If any measurement differs from the arithmetic mean of the results by more than 2 mrad (0,2 per cent inclination), a further series of 10 measurements shall be made, the arithmetic mean of which shall constitute the final result.
- 5.5.3.3. If a vehicle is fitted with an automatic headlamp-levelling system which has an inherent hysteresis loop, average results at the top and bottom of the hysteresis loop shall be taken as significant values.
All these measurements shall be made in accordance with paragraphs 5.5.3.1. and 5.5.3.2.
- 5.5.4. Requirements have been met, if, under all loading conditions, the variation between the measured initial inclination determined in accordance with paragraph 5.2. and the inclination measured under each loading condition is less than the values calculated in paragraph 5.5.1. (without safety margin).
- 5.5.5. If only one of the calculated upper or lower limits of variation is exceeded, the manufacturer shall be permitted to choose a different value for the stated initial inclination, within the limits specified for approval.
-

ANNEX 7

Indication of the downward inclination of the dipped-beam headlamps cut-off referred to in paragraph 6.2.6.1.1. and downward inclination of the front fog lamp cut-off referred to in paragraph 6.3.6.1.2. of this Regulation*Example 1*

The size of the symbol and characters is left to the discretion of the manufacturer.

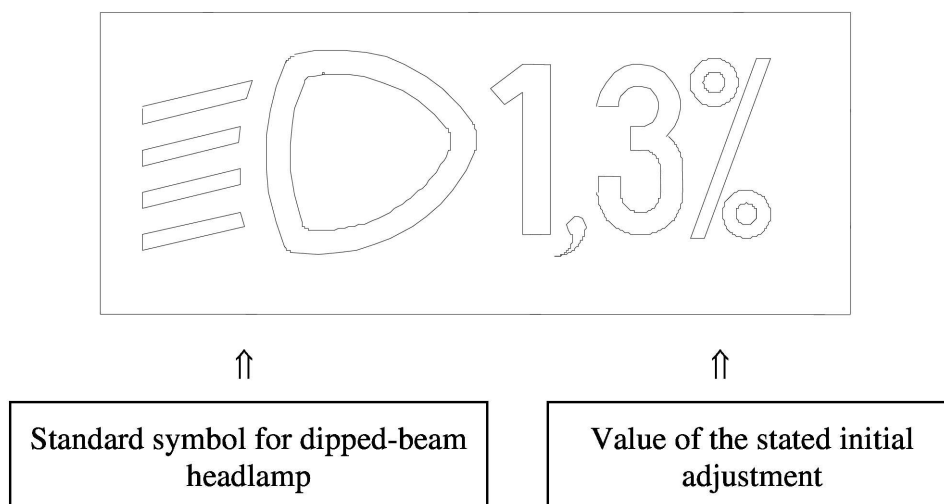
*Example 2*

The size of the symbol and characters is left to the discretion of the manufacturer.

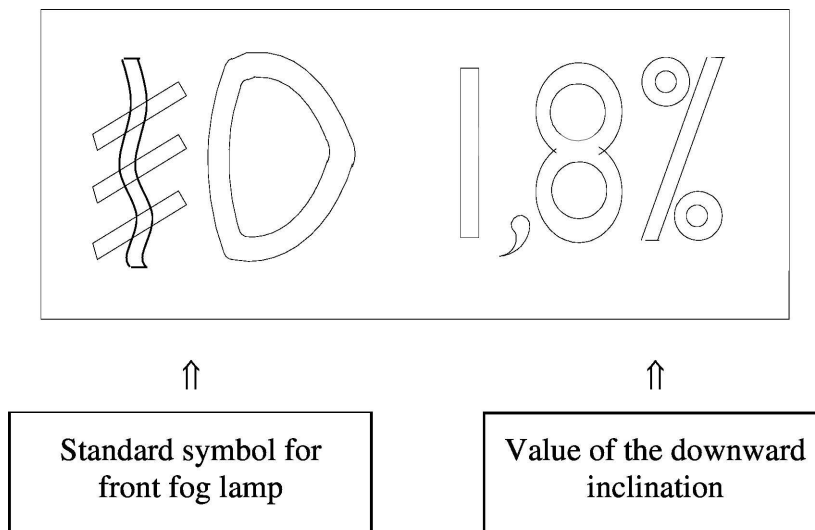

ANNEX 8

The controls for the headlamp-levelling devices referred to in paragraph 6.2.6.2.2. of this Regulation

1. SPECIFICATIONS

1.1. Downward inclination of the dipped-beam shall in all cases be produced in one of the following ways:

- (a) By moving a control downwards or to the left;
- (b) By rotating a control in a counter clockwise direction;
- (c) By depressing a button (push-pull control).

If several buttons are used to adjust the beam, the button which gives the greatest downward inclination shall be installed to the left or below the button(s) for other dipped-beam positions.

A rotary control which is installed edge-on, or with only the edge visible, should follow the operating principles of control of types (a) or (c).

1.1.1. This control shall carry symbols indicating clearly the movements corresponding to the downward and upward inclination of the dipped-beam.

1.2. The "0" position corresponds to the initial inclination according to paragraph 6.2.6.1.1. of this Regulation.

1.3. The "0" position which, according to paragraph 6.2.6.2.2. of this Regulation has to be a "stop position", need not necessarily be at the end of the scale.

1.4. The marks used on control shall be explained in the owner's handbook.

1.5. Only the following symbols may be used to identify the controls:

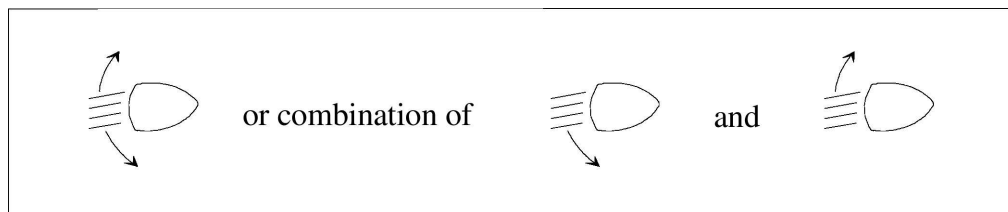

Symbols employing five lines instead of four may also be used

Example 1

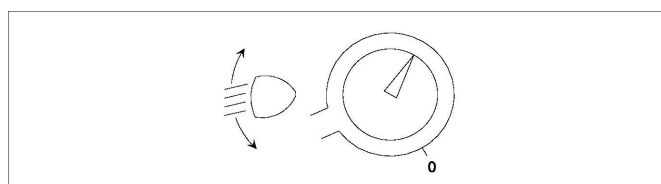

Example 2

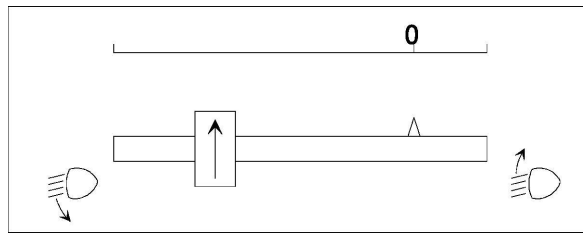

Example 3

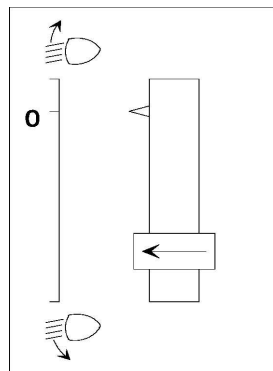

—

ANNEX 9

Control of conformity of production

1. TESTS

1.1. Position of lamps

The position of lamps, as defined in paragraph 2.1.6. of this Regulation, in width, in height and in length shall be checked in accordance with the general requirements set out in paragraphs 2.10.2., 2.10.3., 2.10.4., 2.3.3. and 5.4. of this Regulation.

The values measured for the distances shall be such that the individual specifications applicable to each lamp are fulfilled.

1.2. Visibility of lamps

1.2.1. The angles of geometric visibility shall be checked in accordance with paragraph 2.10.7. of this Regulation .

The values measured for the angles shall be such that the individual specifications applicable to each lamp are fulfilled except that the limits of the angles may have an allowance corresponding to the $\pm 3^\circ$ variation permitted in paragraph 5.3. for the mounting of the light-signalling devices.

1.2.2. The visibility of red light towards the front and of white light towards the rear shall be checked in accordance with paragraph 5.10. of this Regulation.

1.3. Alignment of dipped-beam headlamps and class "F3" front fog lamps towards the front

1.3.1. Initial downward inclination

The initial downward inclination of the cut-off of the dipped-beam and the class "F3" front fog lamps shall be set to the plated figure as required and shown in Annex 7.

Alternatively the manufacturer shall set the initial aim to a figure that is different from the plated figure where it can be shown to be representative of the type approved when tested in accordance with the procedures contained in Annex 6 and in particular paragraph 4.1.

1.3.2. Variation of inclination with load

The variation of the dipped-beam downward inclination as a function of the loading conditions specified within this paragraph shall remain within the range:

0,2 per cent to 2,8 per cent	for headlamp mounting height $h < 0,8$;
0,2 per cent to 2,8 per cent	for headlamp mounting height $0,8 \leq h \leq 1,0$; or
0,7 per cent to 3,3 per cent	(according to the aiming range chosen by the manufacturer at the approval);
0,7 per cent to 3,3 per cent	for headlamp mounting height $1,0 < h \leq 1,2$ m;
1,2 per cent to 3,8 per cent	for headlamp mounting height $h > 1,2$ m.

In the case of a class "F3" front fog lamp with (a) light source(s) having a total objective luminous flux which exceeds 2 000 lumens, the variation of the downward inclination as a function of the loading conditions specified within this paragraph shall remain within the range:

0,7 per cent to 3,3 per cent	for front fog lamp mounting height $h \leq 0,8$;
1,2 per cent to 3,8 per cent	for front fog lamp mounting height $h > 0,8$ m.

The states of loading to be used shall be as follows, as indicated in Annex 5 of this Regulation, for every system adjusted accordingly.

- 1.3.2.1. Vehicles in category M₁:
 - Paragraph 2.1.1.1.
 - Paragraph 2.1.1.6. taking into account
 - Paragraph 2.1.2.
 - 1.3.2.2. Vehicles in category M₂ and M₃:
 - Paragraph 2.2.1.
 - Paragraph 2.2.2.
 - 1.3.2.3. Vehicles in category N with load surfaces:
 - Paragraph 2.3.1.1.
 - Paragraph 2.3.1.2.
 - 1.3.2.4. Vehicles in category N without load surfaces:
 - 1.3.2.4.1. Drawing vehicles for semi-trailers:
 - Paragraph 2.4.1.1.
 - Paragraph 2.4.1.2.
 - 1.3.2.4.2. Drawing vehicles for trailers:
 - Paragraph 2.4.2.1.
 - Paragraph 2.4.2.2.
 - 1.4. Electrical connections and tell-tales

The electrical connections shall be checked by switching on every lamp supplied by the electrical system of the vehicle.

The lamps and tell-tales shall function in accordance with the provisions set out in paragraphs 5.11. to 5.14. of this Regulation and with the individual specifications applicable to each lamp.
 - 1.5. Light intensities
 - 1.5.1. Main-beam headlamps

The aggregate maximum intensity of the main beam headlamps shall be checked by the procedure described in paragraph 6.1.9.2. of this Regulation. The value obtained shall be such that the requirement in paragraph 6.1.9.1. of this Regulation is fulfilled.
 - 1.6. The presence, number, colour, arrangement and, where applicable, the category of lamps shall be checked by visual inspection of the lamps and their markings.

These shall be such that the requirements set out in paragraphs 5.15. and 5.16. as well as in the individual specifications applicable to each lamp are fulfilled.
-

ANNEX 10

Reserved

—

ANNEX 11

Visibility of conspicuity markings to the rear, front and side of a vehicle

(See paragraph 6.21.5. of this Regulation)

Figure 1a

Rear

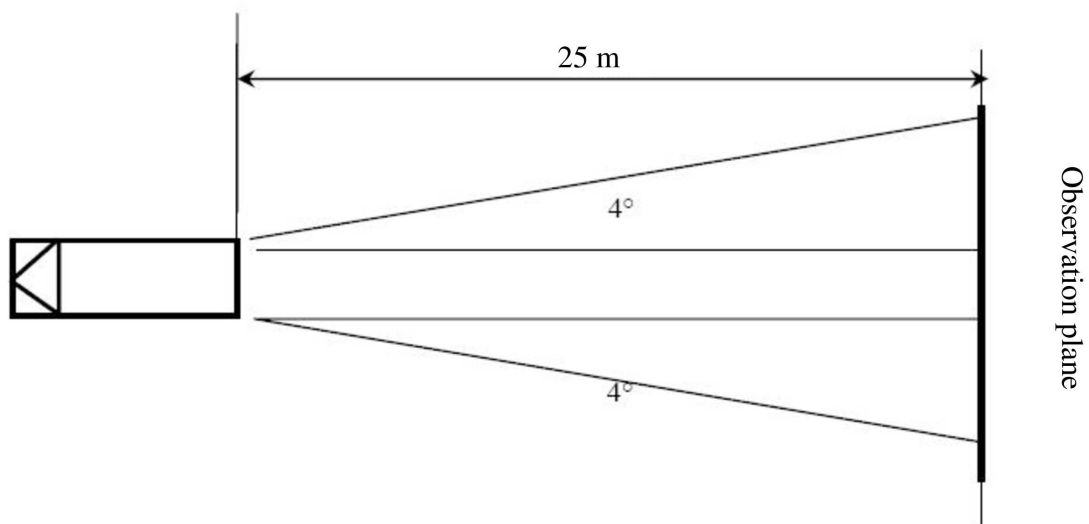

Figure 1b

Front (trailers only)

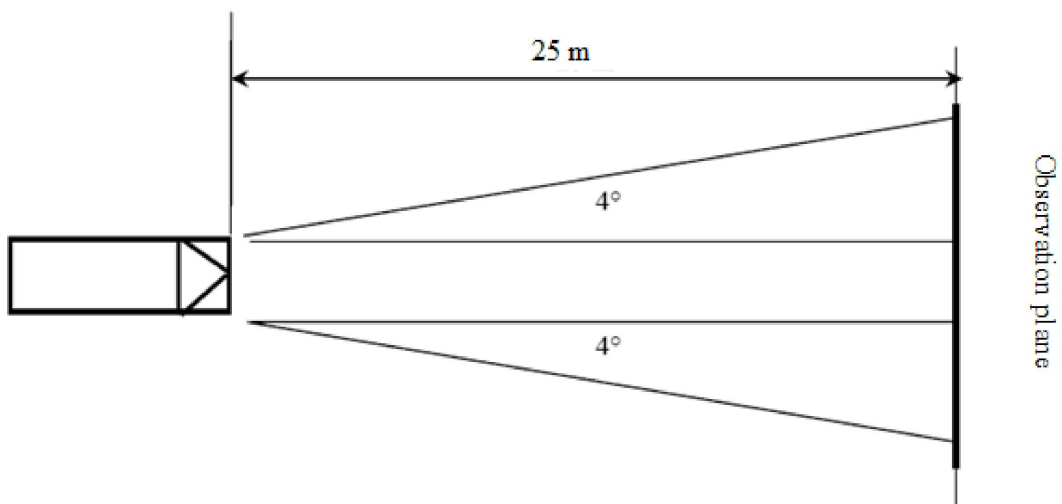
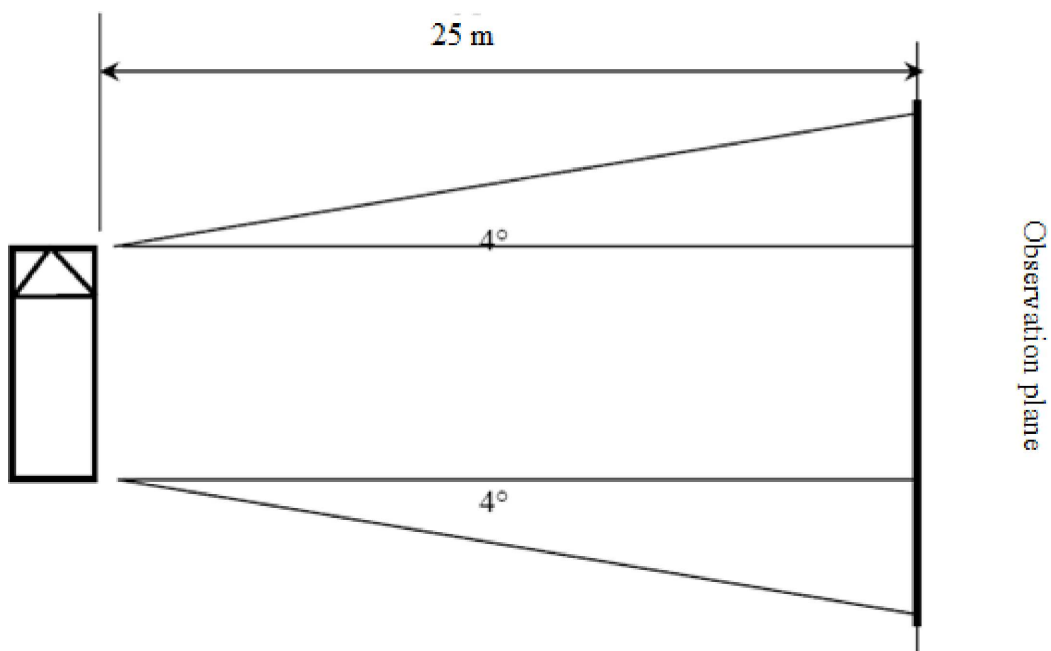

Figure 2

Side



—

ANNEX 12

Test drive

1. Test drive specifications for the automatic control of the main-beam headlamps
 - 1.1. The test drive shall be carried out in clear atmosphere ⁽¹⁾ and with clean head-lamps
 - 1.2. The test course shall comprise test sections with traffic conditions, at speed corresponding to the relevant type of road, as described in Table 1 below:

Table 1

Test Section	Traffic conditions	Road type		
		Urban areas	Multi-lane road, e.g. motorway	Country road
	Speed	50 ± 10 km/h	100 ± 20 km/h	80 ± 20 km/h
	Average percentage of the full test course length	10 per cent	20 per cent	70 per cent
A	Single oncoming vehicle or single preceding vehicle in a frequency so that the main beam will switch ON and OFF.		X	X
B	Combined oncoming and preceding traffic situations, in a frequency so that the main beam will switch ON and OFF.		X	X
C	Active and passive overtaking manoeuvres, in a frequency so that the main beam will switch ON and OFF.		X	X
D	Oncoming bicycle, as described in paragraph 6.1.9.3.1.2.			X
E	Combined oncoming and preceding traffic situations	X		

- 1.3. Urban areas shall comprise roads with and without illumination.
 - 1.4. Country roads shall comprise sections having two lanes and sections having four or more lanes and shall include junctions, hills and/or slopes, dips and winding roads.
 - 1.5. Multi-lane roads (e.g. motorways) and country roads shall comprise sections having straight level parts with a length of more than 600 m. Additionally they shall comprise sections having curves to the left and to the right.
 - 1.6. Dense traffic situations shall be taken into account.”
2. Test drive specifications for adaptive main-beam headlamps
 - 2.1. The test drive shall be carried out in clear atmosphere ⁽²⁾ and with clean head-lamps.

⁽¹⁾ Good visibility (meteorological optical range MOR > 2 000 m defined according to WMO, Guide to Meteorological Instruments and Methods of Observation, Sixth Edition, ISBN: 92-63-16008-2, pp 1. 9. 1/ 1. 9. 11, Geneva 1996).

⁽²⁾ Good visibility (meteorological optical range MOR > 2 000 m defined according to WMO, Guide to Meteorological Instruments and Methods of Observation, Sixth Edition, ISBN: 92-63-16008-2, pp 1. 9. 1/ 1. 9. 11, Geneva 1996)

- 2.2. The test course shall comprise test sections with traffic conditions, at speed corresponding to the relevant type of road, as described in Table 2 below:

Table 2

Test Section	Traffic conditions	Road type		
		Urban areas	Multi-lane road, e.g. motorway	Country road
	Speed	50 ± 10km/h	100 ± 20km/h	80 ± 20km/h
	Average percentage of the full test course length	10 per cent	20 per cent	70 per cent
A	Single oncoming vehicle or single preceding vehicle in a frequency so that the adaptive main beam will react to demonstrate the adaptation process.		X	X
B	Combined oncoming and preceding traffic situations, in a frequency so that the adaptive main beam will react to demonstrate the adaptation process.		X	X
C	Active and passive overtaking manoeuvres, in a frequency so that the adaptive main beam will react to demonstrate the adaptation process.		X	X
D	Oncoming bicycle, as described in paragraph 6.22.9.3.1.2.			X
E	Combined oncoming and preceding traffic situations	X		

- 2.3. Urban areas shall comprise roads with and without illumination.
- 2.4. Country roads shall comprise sections having two lanes and sections having four or more lanes and shall include junctions, hills and/or slopes, dips and winding roads.
- 2.5. Multi lane roads (e.g. motorways) and country roads shall comprise sections having straight level parts with a length of more than 600 m. Additionally they shall comprise of sections having curves to the left and to the right.
- 2.6. Dense traffic situations shall be taken into account
- 2.7. For the test sections A and B in the table above the engineers conducting the tests shall evaluate and record the acceptability of the performance of the adaptation process in relation to oncoming and preceding road users. This means that the test engineers shall be seated in the vehicle being tested and additionally be seated in the oncoming and preceding vehicles.

ANNEX 13

Automatic switching conditions dipped-beam headlamps

Automatic switching conditions dipped-beam headlamps ⁽¹⁾		
Ambient light outside the vehicle ⁽²⁾	Dipped-beam headlamps	Response time
less than 1 000 lux	ON	no more than 2 seconds
between 1 000 lux and 7 000 lux	at manufacturer's discretion	at manufacturer's discretion
more than 7 000 lux	OFF	more than 5 seconds, but no more than 300 seconds

⁽¹⁾ Compliance with these conditions shall be demonstrated by the applicant, by simulation or other means of verification accepted by the Type Approval Authority.

⁽²⁾ The illuminance shall be measured on a horizontal surface, with a cosine corrected sensor on the same height as the mounting position of the sensor on the vehicle. This may be demonstrated by the manufacturer by sufficient documentation or by other means accepted by the Type Approval Authority.

ANNEX 14

Observing area towards the apparent surface of manoeuvring and courtesy lamps

Zones of observation

This drawing shows the zone from one side, the other zones are from the front, the rear and from the other side of the vehicle

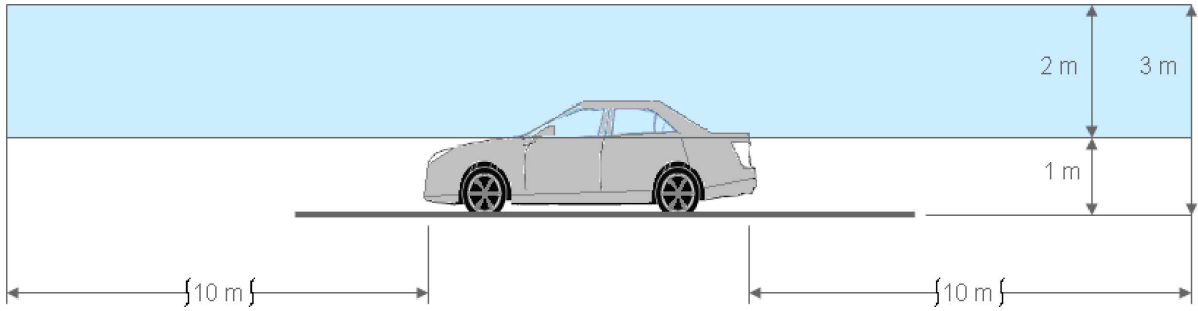

Boundaries of the zones

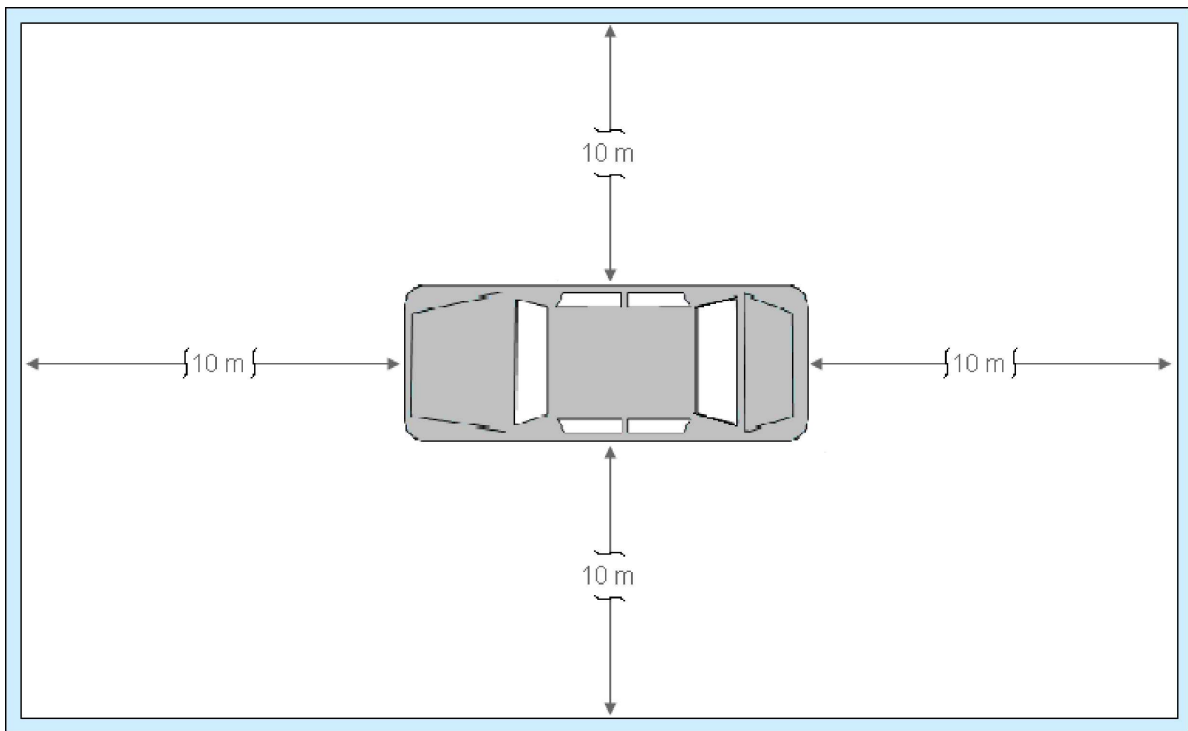

ANNEX 15

Gonio(photo)meter system used for the photometric measurements as defined in paragraph 2.10.9. of this Regulation

