

ACTS ADOPTED BY BODIES CREATED BY INTERNATIONAL AGREEMENTS

Only the original UN/ECE texts have legal effect under international public law. The status and date of entry into force of this Regulation should be checked in the latest version of the UN/ECE status document TRANS/WP.29/343, available at: <http://www.unece.org/trans/main/wp29/wp29wgs/wp29gen/wp29fdocstts.html>

UN Regulation No 14 — Uniform provisions concerning the approval of vehicles with regard to safety-belt anchorages [2019/2141]

Incorporating all valid text up to:

09 series of amendments — Date of entry into force: 29 December 2018

CONTENTS

REGULATION

1. Scope
2. Definitions
3. Application for approval
4. Approval
5. Specifications
6. Tests
7. Inspection during and after static tests for safety-belt anchorages
8. Modifications and extension of approval of the vehicle type
9. Conformity of production
10. Penalties for non-conformity of production
11. Operating instructions
12. Production definitively discontinued
13. Names and addresses of Technical Services responsible for conducting approval tests, and of Type Approval Authorities
14. Transitional provisions

ANNEXES

1. Communication
2. Arrangements of the approval mark
3. Location of effective belt anchorages
4. Procedure for determining the "H" point and the actual torso angle for seating positions in motor vehicles
5. Traction device
6. Minimum number of anchorage points and location of lower anchorages
7. Dynamic test as an alternative to the safety-belt anchorages static strength test
8. Dummy specifications

1. SCOPE

This Regulation applies to:

Vehicles of categories M and N ⁽¹⁾ with regard to their anchorages for safety-belts intended for adult occupants of forward-facing or rearward-facing or side-facing seats.

2. DEFINITIONS

For the purposes of this Regulation,

- 2.1. "Approval of a vehicle" means the approval of a vehicle type equipped with anchorages for given types of safety-belts;
- 2.2. "Vehicle type" means a category of power-driven vehicles, which do not differ in such essential respects as the dimensions, lines and materials of components of the vehicle structure or seat structure to which the safety-belts anchorages are attached and, if the anchorages strength is tested according to the dynamic test, the characteristics of any component of the restraint system, especially the load limiter function, having an influence on the forces applying to the safety-belt anchorages;
- 2.3. "Belt anchorages" means the parts of the vehicle structure or the seat structure or any other part of the vehicle to which the safety-belt assemblies are to be secured;
- 2.4. "Effective belt anchorage" means the point used to determine conventionally, as specified in paragraph 5.4, the angle of each part of the safety-belt in relation to the wearer, that is, the point to which a strap would need to be attached to provide the same lie as the intended lie of the belt when worn, and which may or may not be the actual belt anchorage depending on the configuration of the safety-belt hardware at its attachment to the belt anchorage;
 - 2.4.1. For example, in the case
 - 2.4.1.1. Where a strap guide is used on the vehicle structure or on the seat structure, the middle point of the guide at the place where the strap leaves the guide on the belt wearer's side, shall be considered as the effective belt anchorage; and,
 - 2.4.1.2. where the belt runs directly from the wearer to a retractor attached to the vehicle structure or the seat structure without an intervening strap guide, the effective belt anchorage shall be considered as being the intersection of the axis of the reel for storing the strap with the plane passing through the centre line of the strap on the reel;
- 2.5. "Floor" means the lower part of the vehicle body-work connecting the vehicle side walls. In this context it includes ribs, swages and possibly other reinforcements, even if they are below the floor, such as longitudinal and transverse members;
- 2.6. "Seat" means a structure which may or may not be integral with the vehicle structure complete with trim, intended to seat one adult person. The term covers both an individual seat or part of a bench seat intended to seat one person;
 - 2.6.1. "Front passenger seat" means any seat where the "foremost H point" of the seat in question is in or in front of the vertical transverse plane through the driver's R point;
 - 2.6.2. "Forward-facing seat" means a seat which can be used while the vehicle is in motion and which faces towards the front of the vehicle in such a manner that the vertical plane of symmetry of the seat forms an angle of less than +10° or -10° with the vertical plane of symmetry of the vehicle;
 - 2.6.3. "Rearward-facing seat" means a seat which can be used while the vehicle is in motion and which faces towards the rear of the vehicle in such a manner that the vertical plane of symmetry of the seat forms an angle of less than +10° or -10° with the vertical plane of symmetry of the vehicle;

⁽¹⁾ As defined in the Consolidated resolution on the Construction of vehicles (R.E.3), document ECE/TRANS/WP.29/78/Rev.6, para. 2.

- 2.6.4. "Side-facing seat" means a seat which can be used while the vehicle is in motion and which faces towards the side of the vehicle in such a manner that the vertical plane of symmetry of the seat forms an angle of 90° (\pm 10°) with the vertical plane of symmetry of the vehicle;
- 2.7. "Group of seats" means either a bench-type seat, or seats which are separate but side by side (i.e. with the foremost anchorages of one seat in line with or forward of the rearmost anchorages and in line with or behind the foremost anchorages of another seat) and accommodate one or more seated adult person;
- 2.8. "Bench seat" means a structure complete with trim, intended to seat more than one adult person;
- 2.9. "Seat type" means a category of seats which do not differ in such essential respects as:
- 2.9.1. The shape, dimensions and materials of the seat structure,
- 2.9.2. The types and dimensions of the adjustment systems and all locking systems,
- 2.9.3. The type and dimensions of the belt anchorages on the seat, of the seat anchorage and of the affected parts of the vehicle structure;
- 2.10. "Seat anchorage" means the system by which the seat assembly is secured to the vehicle structure, including the affected parts of the vehicle structure;
- 2.11. "Adjustment system" means the device by which the seat or its parts can be adjusted to a position suited to the morphology of the seated occupant; this device may, in particular, permit of:
- 2.11.1. Longitudinal displacement;
- 2.11.2. Vertical displacement;
- 2.11.3. Angular displacement;
- 2.12. "Displacement system" means a device enabling the seat or one of its parts to be displaced or rotated without a fixed intermediate position, to permit easy access to the space behind the seat concerned;
- 2.13. "Locking system" means any device ensuring that the seat and its parts are maintained in any position of use and includes devices to lock both the seat back relative to the seat and the seat relative to the vehicle;
- 2.14. "Reference zone" means the space between two vertical longitudinal planes, 400 mm apart and symmetrical with respect to the H point, and defined by rotation from vertical to horizontal of the head form apparatus, as described in Regulation No 21, Annex 1. The apparatus shall be positioned as described in that Annex to Regulation No 21 and set to the maximum length of 840 mm;
- 2.15. "Thorax load limiter function" means any part of the safety-belt and/or the seat and/or the vehicle intended to limit the level of the restraint forces applying to the occupant thorax in case of a collision.
3. APPLICATION FOR APPROVAL
- 3.1. The application for approval of a vehicle type with regard to the belt anchorages, shall be submitted by the vehicle manufacturer or by his duly accredited representative.

- 3.2. It shall be accompanied by the under mentioned documents in triplicate and by the following particulars:
- 3.2.1. Drawings of the general vehicle structure on an appropriate scale, showing the positions of the belt anchorages, of the effective belt anchorages (where appropriate) and detailed drawings of the belt anchorages;
- 3.2.2. A specification of the materials used which may affect the strength of the belt anchorages;
- 3.2.3. A technical description of the belt anchorages;
- 3.2.4. In the case of belt anchorages affixed to the seat structure:
- 3.2.4.1. Detailed description of the vehicle type with regard to the design of the seats, of the seat anchorages and of their adjustment and locking systems;
- 3.2.4.2. Drawings, on an appropriate scale and in sufficient detail, of the seats, of their anchorage to the vehicle, and of their adjustment and locking systems.
- 3.2.5. Evidence that the safety-belt or the restraint system used in the anchorages approval test complies with UN Regulation No 16, in the case where the car manufacturer chooses the alternative dynamic strength test.
- 3.3. At the option of the manufacturer, a vehicle representative of the vehicle type to be approved or the parts of the vehicle considered essential for the belt anchorages test, by the technical service conducting approval tests shall be submitted to the service.
4. APPROVAL
- 4.1. If the vehicle submitted for approval pursuant to this Regulation meets the relevant requirements of this Regulation, approval of that vehicle type shall be granted.
- 4.2. An approval number shall be assigned to each type approved. Its first two digits (at present 08, corresponding to the 08 series of amendments) shall indicate the series of amendments incorporating the most recent major technical amendments made to the Regulation at the time of issue of the approval. The same Contracting Party may not assign the same number to another vehicle type as defined in paragraph 2.2 above.
- 4.3. Notice of approval or of extension or refusal or withdrawal of approval or production definitely discontinued of a vehicle type pursuant to this Regulation shall be communicated to the Parties to the 1958 Agreement which apply this Regulation by means of a form conforming to the model in Annex 1 to the Regulation.
- 4.4. There shall be affixed, conspicuously and in a readily accessible place specified on the approval form, to every vehicle conforming to a vehicle type approved under this Regulation an international approval mark consisting of:
- 4.4.1. A circle surrounding the letter 'E' followed by the distinguishing number of the country which has granted approval⁽²⁾;
- 4.4.2. The number of this Regulation, to the right of the circle prescribed in paragraph 4.4.1.

⁽²⁾ The distinguish numbers of the Contracting Parties to the 1958 Agreement are reproduced in Annex 3 to Consolidated Resolution on the Construction of Vehicles (R.E.3), document ECE/TRANS/WP.29/78/Rev.6 - <http://www.unece.org/trans/main/wp29/wp29wgs/wp29gen/wp29resolutions.html>

- 4.4.3. The letter 'e', to the right of the number of this Regulation in the case of type approval according to the dynamic test of Annex 7.
- 4.5. If the vehicle conforms to a vehicle type approved, under one or more other Regulations Annexed to the Agreement, in the country which has granted approval under this Regulation, the symbol prescribed in paragraph 4.4.1 need not be repeated; in such a case the additional numbers and symbols of all the Regulations under which approval has been granted in the country which has granted approval under this Regulation shall be placed in vertical columns to the right of the symbol prescribed in paragraph 4.4.1.
- 4.6. The approval mark shall be clearly legible and be indelible.
- 4.7. The approval mark shall be placed close to or on the vehicle data plate affixed by the manufacturer.
- 4.8. Annex 2 to this Regulation gives examples of arrangements of the approval mark.
5. SPECIFICATIONS
- 5.1. Definitions (see Annex 3)
- 5.1.1. The H point is a reference point as defined in paragraph 2.3 of Annex 4 of this Regulation, which must be determined in accordance with the procedure set out in that Annex.
- 5.1.1.1. Point H' is a reference point corresponding to H as defined in paragraph 5.1.1 which shall be determined for every normal position in which the seat is used.
- 5.1.1.2. The R point is the seating reference point defined in paragraph 2.4 of Annex 4 of this Regulation.
- 5.1.2. The three-dimensional reference system is defined in Appendix 2 of Annex 4 of this Regulation.
- 5.1.3. Points L_1 and L_2 are the lower effective belt anchorages.
- 5.1.4. Point C is a point situated 450 mm vertically above the R point. However, if the distance S as defined in paragraph 5.1.6 is not less than 280 mm and if the alternative formula $BR = 260 \text{ mm} + 0,8 S$ specified in paragraph 5.4.3.3 is chosen by the manufacturer, the vertical distance between C and R shall be 500 mm.
- 5.1.5. The angles α_1 and α_2 are respectively the angles between a horizontal plane and planes perpendicular to the median vertical longitudinal plane of the seat and passing through the R-point and the points L_1 and L_2 .
If the seat is adjustable, this requirement shall be fulfilled also for the H-points of all normal driving or riding positions, as indicated by the vehicle manufacturer.
- 5.1.6. S is the distance in millimetres of the effective upper belt anchorages from a reference plane P parallel to the longitudinal median plane of the vehicle defined as follows:
- 5.1.6.1. If the seating position is well-defined by the shape of the seat, the plane P shall be the median plane of this seat.
- 5.1.6.2. In the absence of a well-defined position:
- 5.1.6.2.1. The plane P for the driver's seat is a vertical plane parallel to the median longitudinal plane of the vehicle which passes through the centre of the steering-wheel in the plane of the steering-wheel rim when the steering-wheel, if adjustable, is in its central position.
- 5.1.6.2.2. The plane P for the front outboard passenger shall be symmetrical with that of the driver.

- 5.1.6.2.3. The plane P for the rear outboard seating position shall be that specified by the manufacturer on condition the following limits for distance A between the longitudinal median plane of the vehicle and plane P are respected:
- A Is equal or more than 200 mm if the bench seat has been designed to accommodate two passengers only,
A Is equal or more than 300 mm if the bench seat has been designed to accommodate more than two passengers.
- 5.2. General specifications
- 5.2.1. Anchorages for safety-belts shall be so designed, made and situated as to:
- 5.2.1.1. Enable the installation of a suitable safety-belt. The belt anchorages of the front outboard positions shall be suitable for safety-belts incorporating a retractor and pulley, taking into consideration in particular the strength characteristics of the belt anchorages, unless the manufacturer supplies the vehicle equipped with other types of safety-belts which incorporate retractors. If the anchorages are suitable only for particular types of safety-belts, these types shall be stated on the form mentioned in paragraph 4.3 above;
- 5.2.1.2. Reduce to a minimum the risk of the belt's slipping when worn correctly;
- 5.2.1.3. Reduce to a minimum the risk of strap damage due to contact with sharp rigid parts of the vehicle or seat structures;
- 5.2.1.4. Enable the vehicle, in normal use, to comply with the provisions of this Regulation;
- 5.2.1.5. For anchorages which take up different positions to allow persons to enter the vehicle and to restrain the occupants, the specifications of this Regulation shall apply to the anchorages in the effective restraint position.
- 5.3. Minimum number of belt anchorages to be provided
- 5.3.1. Any vehicle in categories M and N (except those vehicles of categories M₂ or M₃ which belong to Classes I or A¹) shall be equipped with safety-belt anchorages which satisfy the requirements of this Regulation.
- If vehicles of categories M₂ or M₃ which belong to Classes I or A¹ are fitted with safety-belt anchorages, these anchorages shall satisfy the requirements of this Regulation.
- 5.3.1.1. The anchorages of a harness belt system approved as a S-type belt (with or without retractor(s)) according to Regulation No 16 shall comply with the requirements of Regulation No 14, but the additional anchorage or anchorages provided for the fitting of a crotch strap (assembly) are exempted from the strength and location requirements of this Regulation.
- 5.3.2. The minimum number of safety-belt anchorages for each forward, rearward and side-facing seating position shall be those specified in Annex 6.
- 5.3.3. However, for outboard seating positions, other than front, of vehicles of category N₁, shown in Annex 6 and marked with the symbol Ø, two lower anchorages are allowed, where there exists a passage between a seat and the nearest side-wall of the vehicle intended to permit access of passengers to other parts of the vehicle.
- A space between a seat and the side-wall is considered as a passage if the distance between that side-wall, with all doors closed, and a vertical longitudinal plane passing through the centre line of the seat concerned, measured at the R point position and perpendicularly to the median longitudinal plane of the vehicle is more than 500 mm.
- 5.3.4. For the front centre seating positions shown in Annex 6 and marked with the symbol *, two lower anchorages shall be considered adequate where the windscreen is located outside the reference zone defined in Annex 1 to Regulation No 21; if located inside the reference zone, three anchorages are required.

As regards belt anchorages, the windscreen is considered as part of the reference zone when it is capable of entering into static contact with the test apparatus according to the method described in Annex 1 to Regulation No 21.

- 5.3.5. In every seating position marked in Annex 6 with symbol $\frac{4}{T}$, three anchorages shall be provided. Two anchorages may be provided if one of the following conditions is fulfilled:
- 5.3.5.1. There is a seat or other parts of the vehicle conforming to Regulation No 80, Appendix 1, paragraph 3.5 directly in front, or
- 5.3.5.2. No part of the vehicle is in the reference zone, or capable of being in the reference zone when the vehicle is in motion, or
- 5.3.5.3. Parts of the vehicle within the said reference zone comply with the energy absorbing requirements set out in Regulation No 80, Appendix 6.
- 5.3.5.4. Paragraphs 5.3.5.1 to 5.3.5.3 shall not apply to a driver's seat.
- 5.3.6. For all seats, intended solely for use or seating intended solely for use when the vehicle is stationary as well as for all the seats of any vehicle which are not covered by paragraphs 5.3.1 to 5.3.4, no belt anchorages are required. However, if the vehicle is fitted with anchorages for such seats, these anchorages must comply with the provisions of this Regulation. Any anchorage intended solely for use in conjunction with a disabled person's belt, or any other restraint system according to Regulation No 107, 02 series of amendments, Annex 8, do not need to conform to the requirements of this Regulation.
- 5.3.7. In the case of the upper deck of a double-deck vehicle, the requirements for the centre front seating position shall apply also in the outboard front seating positions.
- 5.3.8. In the case of seats capable of being turned to or placed in other orientations, for use when the vehicle is stationary, the requirements of paragraph 5.3.1 shall apply only to those orientations designated for normal use when the vehicle is travelling on a road, in accordance with this Regulation. A note to this effect shall be included in the information document.
- 5.4. Location of belt anchorages (see Annex 3, Figure 1.)
- 5.4.1. General
- 5.4.1.1. The belt anchorages for any one belt may be located either wholly in the vehicle structure or in the seat structure or any other part of the vehicle or dispersed between these locations.
- 5.4.1.2. Any one belt anchorage may be used for attaching the ends of two adjacent safety-belts, provided that the test requirements are met.
- 5.4.2. Location of the effective lower belt anchorage
- 5.4.2.1. Front seats, vehicle category M_1
- In motor vehicles of category M_1 the angle α_1 (other than buckle side) shall be within the range of 30 to 80 degrees and the angle α_2 (buckle side) shall be within the range of 45 to 80 degrees. Both angle requirements shall be valid for all normal travelling positions of the front seats. Where at least one of the angles α_1 and α_2 is constant (e.g. anchorage fixed at the seat) in all normal positions of use, its value shall be $60 \pm 10^\circ$. In the case of adjustable seats with an adjusting system with a seatback angle of less than 20° (see Annex 3, Figure 1), the angle α_1 may be below the minimum value (30°) stipulated above, provided it is not less than 20° in any normal position of use.

5.4.2.2. Rear seats, vehicle category M₁

In motor vehicles of category M₁ the angles α_1 and α_2 shall be within the range of 30 to 80 degrees for all rear seats. If rear seats are adjustable the above angles shall be valid for all normal travelling positions.

5.4.2.3. Front seats, vehicle categories other than M₁

In motor vehicles of categories other than M₁ the angles α_1 and α_2 must be between 30 and 80 degrees for all normal travelling positions of the front seats. Where in the case of front seats of vehicles having a maximum vehicle mass not exceeding 3,5 tonnes at least one of the angles α_1 and α_2 is constant in all normal positions of use, its value shall be $60 \pm 10^\circ$ (e.g. anchorage fixed at the seat).

5.4.2.4. Rear seats and special front or rear seats, vehicle categories other than M₁

In vehicles of categories other than M₁, in the case of:

- (a) Bench seats,
- (b) Adjustable seats (front and rear) with an adjusting system with a seatback angle of less than 20° (see Annex 3, Figure 1), and
- (c) Other rear seats,

Angles α_1 and α_2 may be between 20° and 80° in any normal position of use. Where in the case of front seats of vehicles having a maximum vehicle mass not exceeding 3,5 tonnes at least one of the angles α_1 and α_2 is constant in all normal positions of use, its value shall be $60 \pm 10^\circ$ (e.g. anchorage fixed at the seat).

In the case of seats, other than front seats, of vehicles in categories M₂ and M₃, the angles α_1 and α_2 shall be between 45 and 90 degrees for all normal positions of use.

5.4.2.5. The distance between the two vertical planes parallel to the median vertical longitudinal plane of the vehicle and each passing through a different one of the two effective lower belt anchorages L₁ and L₂ of the same safety-belt shall not be less than 350 mm. In the case of side-facing seats the distance between the two vertical planes parallel to the median vertical longitudinal plane of the seat and each passing through a different one of the two effective lower belt anchorages L₁ and L₂ of the same safety-belt shall not be less than 350 mm. If there is only one central seating positions in a rear rows of seats of vehicles of category M₁ and N₁, then the above-mentioned distance shall be not less than 240 mm for that central seating position, provided that it is not possible to exchange the centre rear seat with any of the other seats of the vehicle. The median longitudinal plane of the seat shall pass between points L₁ and L₂ and shall be at least 120 mm from these points.

5.4.3. Location of the effective upper belt anchorages (see Annex 3)

5.4.3.1. If a strap guide or similar device is used which affects the location of the effective upper belt anchorage, this location shall be determined in a conventional way by considering the position of the anchorage when the longitudinal centre line of the strap passes through a point J₁ defined successively from the R point by the following three segments:

- RZ: A segment of the torso line measured in an upward direction from R and 530 mm long;
- ZX: A segment perpendicular to the median longitudinal plane of the vehicle, measured from point Z in the direction of the anchorage and 120 mm long;
- XJ₁: A segment perpendicular to the plane defined by segments RZ and ZX, measured in a forward direction from point X and 60 mm long.

Point J₂ is determined by symmetry with point J₁ about the longitudinal vertical plane passing through the torso line described in paragraph 5.1.2 of the manikin positioned in the seat in question.

Where a two-door configuration is used to provide access to both the front and rear seats and the upper anchorage is fitted to the 'B' post, the system must be designed so as not to impede access to or egress from the vehicle.

- 5.4.3.2. The effective upper anchorage shall lie below the plane FN, which runs perpendicular to the longitudinal median plane of the seat and makes an angle of 65° with the torso line. The angle may be reduced to 60° in the case of rear seats. The plane FN shall be so placed as to intersect the torso line at a point D such that $DR = 315 \text{ mm} + 1,8 S$. However, when $S \leq 200 \text{ mm}$, then $DR = 675 \text{ mm}$.
- 5.4.3.3. The effective upper belt anchorage shall lie behind a plane FK running perpendicular to the longitudinal median plane of the seat and intersecting the torso line at an angle of 120° at a point B such that $BR = 260 \text{ mm} + S$. Where $S \geq 280 \text{ mm}$, the manufacturer may use $BR = 260 \text{ mm} + 0,8 S$ at his discretion.
- 5.4.3.4. The value of S shall not be less than 140 mm.
- 5.4.3.5. The effective upper belt anchorage shall be situated to the rear of a vertical plane perpendicular to the median longitudinal plane of the vehicle and passing through the R point as shown in Annex 3.
- 5.4.3.6. The effective upper belt anchorage shall be situated above a horizontal plane passing through point C defined in paragraph 5.1.4.
- 5.4.3.6.1. Notwithstanding the requirements of paragraph 5.4.3.6 the effective upper belt anchorage for passenger seats of category M_2 and M_3 vehicles may be adjustable below that specification providing the following requirements are met:
- (a) The safety-belt or seat shall be permanently marked to identify the position of the effective upper belt anchorage that is required to satisfy the minimum upper anchorage height position required by paragraph 5.4.3.6. This marking shall clearly indicate to the user when the anchorage is in a position suitable for use by an adult of average stature;
 - (b) The effective upper anchorage shall be so designed to permit adjustment of its height by a manual adjusting device that is readily accessible to the wearer when seated and is convenient and easy to use;
 - (c) The effective upper anchorage shall be so designed to prevent any unintended upward movement of the anchorage that would reduce the effectiveness of the device during normal use;
 - (d) The manufacturer shall include within the vehicle handbook clear guidance on the adjustment of such systems, together with advice on the suitability and limitations for use by occupants of short stature.
- However, where the device for adjusting the shoulder height is not directly attached to the vehicle construction or seat construction, but is realized by means of a flexible shoulder adjustment device for height:
- (e) The requirements mentioned in the subparagraphs (a) and (d) above shall still be fulfilled as part of the Regulation No 14 type approval making use of the restraint system that is to be installed.
 - (f) Evidence is needed that the safety-belt together with its flexible shoulder adjustment for height complies with the requirements for restraint systems of Regulation No 16; the requirements in the subparagraphs (b) and (c) shall be fulfilled under paragraph 8.3 of Regulation No 16 type approval.
- 5.4.3.7. In addition to the upper anchorage specified in paragraph 5.4.3.1 other effective upper anchorages may be provided if one of the following conditions is satisfied:
- 5.4.3.7.1. The additional anchorages comply with the requirements of paragraphs 5.4.3.1 to 5.4.3.6.

- 5.4.3.7.2. The additional anchorages can be used without the aid of tools, comply with the requirements of paragraphs 5.4.3.5 and 5.4.3.6 and are located in one of the areas determined by shifting the area shown in Figure 1 of Annex 3 of this Regulation, 80 mm upwards or downwards in a vertical direction.
- 5.4.3.7.3. The anchorage(s) is/are intended for a harness belt, complies/comply with the requirements laid down in paragraph 5.4.3.6 if it lie(s) behind the transverse plane passing through the reference line and is/are located:
- 5.4.3.7.3.1. In the case of a single anchorage, within the area common to two dihedrals defined by the verticals passing through points J_1 and J_2 as defined in paragraph 5.4.3.1 and whose horizontal sections are shown in Figure 2 of Annex 3 of this Regulation;
- 5.4.3.7.3.2. In the case of two anchorages, within whichever of the above defined dihedrals is suitable, provided that each anchorage is not more than 50 mm distant from the symmetrically-located, mirror-image position of the other anchorage about plane P, as defined in paragraph 5.1.6 of the seat in question.
- 5.5. Dimensions of threaded anchorage holes
- 5.5.1. An anchorage shall have a threaded hole of 7/16 inch (20 UNF 2B).
- 5.5.2. If the vehicle is fitted by the manufacturer with safety-belts which are attached to all anchorages prescribed for the seat in question, these anchorages need not meet the requirement set out in paragraph 5.5.1, provided that they comply with the other provisions of this Regulation. In addition, the requirement set out in paragraph 5.5.1 shall not apply to additional anchorages which meet the requirement set out in paragraph 5.4.3.7.3.
- 5.5.3. It shall be possible to remove the safety-belt without damaging the anchorage.
6. TESTS
- 6.1. General tests for safety-belt anchorages
- 6.1.1. Subject to application of the provisions of paragraph 6.2, and at the request of the manufacturer;
- 6.1.1.1. The tests may be carried out either on a vehicle structure or on a completely finished vehicle;
- 6.1.1.2. The tests may be restricted to the anchorages relating to only one seat or one group of seats on the condition that:
- (a) The anchorages concerned have the same structural characteristics as the anchorages relating to the other seats or group of seats; and
- (b) Where such anchorages are fitted totally or partially on the seat or group of seats, the structural characteristics of the seat or group of seats are the same as those for the other seats or groups of seats.
- 6.1.1.3. Windows and doors may be fitted or not and closed or not;
- 6.1.1.4. Any fitting normally provided and likely to contribute to the rigidity of the vehicle structure may be fitted.
- 6.1.2. The seats shall be fitted and placed in the position for driving or use chosen by the technical service responsible for conducting approval tests to give the most adverse conditions with respect to the strength of the system. The position of the seats shall be stated in the report. The seat-back shall, if its inclination is adjustable, be locked as specified by the manufacturer or, in the absence of any such specification, in a position corresponding to an effective seat-back angle as close as possible to 25° for vehicles of categories M₁ and N₁ and to 15° for vehicles of all other categories.

- 6.2. Securing the vehicle for safety-belt anchorages tests.
- 6.2.1. The method used to secure the vehicle during the test shall not be such as to strengthen the safety-belt anchorages and their anchorage area or to lessen the normal deformation of the structure.
- 6.2.2. A securing device shall be regarded as satisfactory if it produces no effect on an area extending over the whole width of the structure and if the vehicle or the structure is blocked or fixed in front at a distance of not less than 500 mm from the anchorage to be tested and is held or fixed at the rear not less than 300 mm from that anchorage.
- 6.2.3. It is recommended that the structure should rest on supports arranged approximately in line with the axes of the wheels or, if that is not possible, in line with the points of attachment of the suspension.
- 6.2.4. If a securing method other than that prescribed in paragraphs 6.2.1 to 6.2.3 of this Regulation is used, evidence must be furnished that it is equivalent.
- 6.3. General test requirements for safety-belt anchorages
- 6.3.1. All the belt anchorages of the same group of seats shall be tested simultaneously. However, if there is a risk that non-symmetrical loading of the seats and/or anchorages may lead to failures, an additional test may be carried out with non-symmetrical loading.
- 6.3.2. The tractive force shall be applied at an angle of 10 degrees \pm 5° above the horizontal, in a plane parallel to the median longitudinal plane of the vehicle.
A preload of 10 per cent with a tolerance of \pm 30 per cent of the target load shall be applied; the load shall be increased to 100 per cent of the relevant target load.
- 6.3.3. Full application of the load shall be achieved as rapidly as possible, and within a maximum load application time of 60 seconds.
However, the manufacturer may request the application of the load to be achieved within 4 seconds.
The belt anchorages must withstand the specified load for not less than 0,2 second.
- 6.3.4. Traction devices to be used in the tests described in paragraph 6.4 below are shown in Annex 5. The devices shown in Annex 5, Figure 1 are placed onto the seat cushion and then, when possible, pushed back into the seat back while the belt strap is pulled tight around it. The device shown in Annex 5, Figure 2 is placed in position, the belt strap is fitted over the device and pulled tight. No preload beyond the minimum necessary for correct positioning of the test device shall be introduced to safety-belt anchorages during this operation.
The traction device of either 254 mm or 406 mm used at each seating position shall be such that its width is as close as possible to the distance between the lower anchorages.
The positioning of the traction device shall avoid any mutual influences during the pull test which adversely affects the load and load distribution.
- 6.3.5. The belt anchorages for seats for which upper belt anchorages are provided shall be tested under the following conditions:
- 6.3.5.1. Front outboard seats:
The belt anchorages shall be submitted to the test prescribed in paragraph 6.4.1 in which the loads are transmitted to them by means of a device reproducing the geometry of a three-point belt equipped with a retractor having a pulley or strap guide at the upper belt anchorage. In addition, if the number of anchorages is more than that prescribed in paragraph 5.3, these anchorages shall be subjected to the test specified in paragraph 6.4.5, in which the loads shall be transmitted to the anchorages by means of a device reproducing the geometry of the type of safety-belt intended to be attached to them.

- 6.3.5.1.1. In the case where the retractor is not attached to the required outboard lower belt anchorage or in the case where the retractor is attached to the upper belt anchorage, the lower belt anchorages shall also be submitted to the test prescribed in paragraph 6.4.3.
- 6.3.5.1.2. In the above case the tests prescribed in paragraphs 6.4.1 and 6.4.3 can be performed on two different structures if the manufacturer so requests.
- 6.3.5.2. Rear outboard seats and all centre seats:
The belt anchorages shall be subjected to the test prescribed in paragraph 6.4.2 in which the loads are transmitted to them by means of a device reproducing the geometry of a three-point safety-belt without a retractor, and to the test prescribed in paragraph 6.4.3, in which the loads are transmitted to the two lower belt anchorages by means of a device reproducing the geometry of a lap belt. The two tests can be performed on two different structures if the manufacturer so requests.
- 6.3.5.3. When a manufacturer supplies his vehicle with safety-belts, the corresponding belt anchorages may, at the request of the manufacturer, be submitted only to a test in which the loads are transmitted to them by means of a device reproducing the geometry of the type of belts to be attached to these anchorages.
- 6.3.6. If no upper belt anchorages are provided for the outboard seats and the centre seats, the lower belt anchorages shall be submitted to the test prescribed in paragraph 6.4.3, in which the loads are transmitted to these anchorages by means of a device reproducing the geometry of a lap belt.
- 6.3.7. If the vehicle is designed to accept other devices which do not enable the straps to be directly attached to belt anchorages without intervening sheaves, etc. or which require belt anchorages supplementary to those mentioned in paragraph 5.3, the safety-belt or an arrangement of wires, sheaves, etc. representing the equipment of the safety-belt, shall be attached by such a device to the belt anchorages in the vehicle and the belt anchorages shall be subjected to the tests prescribed in paragraph 6.4, as appropriate.
- 6.3.8. A test method other than those prescribed in paragraph 6.3 may be used, but evidence must be furnished that it is equivalent.
- 6.4. Particular test requirements for safety-belt anchorages
- 6.4.1. Test in configuration of a three-point belt incorporating a retractor having a pulley or strap guide at the upper belt anchorage
- 6.4.1.1. A special pulley or guide for the wire or strap appropriate to transmit the load from the traction device, or the pulley or strap guide supplied by the manufacturer shall be fitted to the upper belt anchorage.
- 6.4.1.2. A test load of $1,350 \text{ daN} \pm 20 \text{ daN}$ shall be applied to a traction device (see Annex 5, Figure 2) attached to the belt anchorages of the same belt, by means of a device reproducing the geometry of the upper torso strap of such a safety-belt. In the case of vehicles of categories other than M_1 and N_1 , the test load shall be $675 \pm 20 \text{ daN}$, except that for M_3 and N_3 vehicles the test load shall be $450 \pm 20 \text{ daN}$.
- 6.4.1.3. At the same time a tractive force of $1,350 \text{ daN} \pm 20 \text{ daN}$ shall be applied to a traction device (see Annex 5, Figure 1) attached to the two lower belt anchorages. In the case of vehicles of categories other than M_1 and N_1 , the test load shall be $675 \pm 20 \text{ daN}$, except that for M_3 and N_3 vehicles the test load shall be $450 \pm 20 \text{ daN}$.
- 6.4.2. Test in configuration of a three-point belt without retractor or with a retractor at the upper belt anchorage

- 6.4.2.1. A test load of $1,350 \text{ daN} \pm 20 \text{ daN}$ shall be applied to a traction device (see Annex 5, Figure 2) attached to the upper belt anchorage and to the opposite lower belt anchorage of the same belt using, if supplied by the manufacturer, a retractor fixed at the upper belt anchorage. In the case of vehicles of categories other than M_1 and N_1 , the test load shall be $675 \pm 20 \text{ daN}$, except that for M_3 and N_3 vehicles the test load shall be $450 \pm 20 \text{ daN}$.
- 6.4.2.2. At the same time a tractive force of $1,350 \text{ daN} \pm 20 \text{ daN}$ shall be applied to a traction device (see Annex 5, Figure 1) attached to the lower belt anchorages. In the case of vehicles of categories other than M_1 and N_1 , the test load shall be $675 \pm 20 \text{ daN}$, except that for M_3 and N_3 vehicles the test load shall be $450 \pm 20 \text{ daN}$.
- 6.4.3. Test in configuration of a lap belt
- A test load of $2,225 \text{ daN} \pm 20 \text{ daN}$ shall be applied to a traction device (see Annex 5, Figure 1) attached to the two lower belt anchorages. In the case of vehicles of categories other than M_1 and N_1 , the test load shall be $1,110 \pm 20 \text{ daN}$, except that for M_3 and N_3 vehicles the test load shall be $740 \pm 20 \text{ daN}$.
- 6.4.4. Test for belt anchorages located wholly within the seat structure or dispersed between the vehicle structure and the seat structure
- 6.4.4.1. The test specified in paragraphs 6.4.1, 6.4.2 and 6.4.3 above shall be performed, as appropriate, at the same time superimposing for each seat and for each group of seats a force as stated below.
- 6.4.4.2. The loads indicated in paragraphs 6.4.1, 6.4.2 and 6.4.3 above shall be supplemented by a force equal to 20 times the mass of the complete seat. The inertia load shall be applied to the seat or to the relevant parts of the seat corresponding to the physical effect of the mass of the seat in question to the seat anchorages. The determination of the additional applied load or loads and the load distribution shall be made by the manufacturer and agreed by the Technical Service.
- In the case of vehicles in categories M_2 and N_2 , this force must be equal to 10 times the mass of the complete seat; for categories M_3 and N_3 it shall be equal to 6,6 times the mass of the complete seat.
- 6.4.5. Test in configuration of a special-type belt
- 6.4.5.1. A test load of $1,350 \pm 20 \text{ daN}$ shall be applied to a traction device (see Annex 5, Figure 2) attached to the belt anchorages of such a safety-belt by means of a device reproducing the geometry of the upper torso strap or straps.
- 6.4.5.2. At the same time, a tractive force of $1,350 \pm 20 \text{ daN}$ shall be applied to a traction device (see Annex 5, Figure 3) attached to the two lower belt anchorages.
- 6.4.5.3. In the case of vehicles of categories other than M_1 and N_1 , this test load shall be $675 \pm 20 \text{ daN}$, except that for M_3 and N_3 vehicles the test load shall be $450 \pm 20 \text{ daN}$.
- 6.4.6. Test in the case of rearward-facing seats
- 6.4.6.1. The anchorage points shall be tested according to the forces prescribed in paragraphs 6.4.1, 6.4.2 or 6.4.3, as appropriate. In each case the test load shall correspond to the load prescribed for M_3 or N_3 vehicles.
- 6.4.6.2. The test load shall be directed forward in relation to the seating position in question, corresponding to the procedure prescribed in paragraph 6.3.

- 6.4.7. Test in the case of side-facing seats
- 6.4.7.1. The anchorage points shall be tested according to the forces prescribed in paragraph 6.4.3 for M₃ vehicles.
- 6.4.7.2. The test load shall be directed forward in relation to the vehicle, corresponding to the procedure prescribed in paragraph 6.3. In the case that side-facing seats are grouped together on a basic structure, the safety-belt anchorage points of each seating position in the group shall be tested separately. In addition the basic structure has to be tested as described in paragraph 6.4.8.
- 6.4.7.3. Traction device adapted for the test of side-facing seats is shown in Annex 5, Figure 1b.
- 6.4.8. Test of the basic structure of side-facing seats
- 6.4.8.1. The basic structure of a side-facing seat or a group of side-facing seats shall be tested according to the forces as prescribed in paragraph 6.4.3 for M₃ vehicles.
- 6.4.8.2. The test load shall be directed forward in relation to the vehicle, corresponding to the procedure prescribed in paragraph 6.3. In the case that side-facing seats are grouped together the basic structure shall be tested simultaneously for each seating position in the group.
- 6.4.8.3. The point of application of the forces prescribed in paragraphs 6.4.3 and 6.4.4 shall be as close as possible to the H-Point and on the line defined by a horizontal plane and a vertical transverse plane through the relevant H-Point of each seating position.
- 6.5. In the case of a group of seats as described in paragraph 1. of Annex 7, the dynamic test of Annex 7 can be performed, at the option of the car manufacturer, as an alternative to the static test prescribed in paragraphs 6.3 and 6.4.
7. INSPECTION DURING AND AFTER STATIC TESTS FOR SAFETY-BELT ANCHORAGES
- 7.1. All the anchorages shall be capable of withstanding the test prescribed in paragraphs 6.3 and 6.4. Permanent deformation, including partial rupture or breakage of any anchorage or surrounding area, shall not constitute failure if the required force is sustained for the specified time. During the test, the minimum spacings for the effective lower belt anchorages specified in paragraph 5.4.2.5. and the requirements of paragraph 5.4.3.6. for effective upper belt anchorages shall be respected.
- 7.1.1. For vehicles of category M₁ of a total permissible mass not exceeding 2,5 tonnes, if the upper safety-belt anchorage is attached to the seat structure, the effective upper safety-belt anchorage shall not be displaced during the test forward of a transverse plane passing through the R point and point C of the seat in question (see Figure 1 of Annex 3 to this Regulation)
- For vehicles other than mentioned above, the effective upper safety-belt anchorage shall not be displaced during the test forward of a transverse plane inclined 10° in forward direction and passing through the R point of the seat.
- The maximum displacement of the effective upper anchorage point shall be measured during the test.
- If the displacement of the effective upper anchorage point exceeds the above-mentioned limitation, the manufacturer shall demonstrate to the satisfaction of the technical service that there is no danger to the occupant. As an example, the test procedure according to Regulation No 94 or a sled test with corresponding pulse may be carried out to demonstrate a sufficient survival space.
- 7.2. In vehicles where such devices are used, the displacement and locking devices enabling the occupants of all seats to leave the vehicle must still be operable by hand after the tractive force was removed.

- 7.3. After testing any damage to the anchorages and structures supporting load during tests shall be noted.
- 7.4. By derogation, the upper anchorages fitted to one or more seats of vehicles of category M₃ and those of category M₂ with a maximum mass exceeding 3,5 tonnes, which meet the requirements of Regulation No 80, need not to comply with the requirements of paragraph 7.1 concerning compliance with paragraph 5.4.3.6.
8. MODIFICATIONS AND EXTENSION OF APPROVAL OF THE VEHICLE TYPE
- 8.1. Every modification of the vehicle type shall be notified to the Type Approval Authority which approved the vehicle type. The Authority may then either:
- 8.1.1. Consider that the modifications made are unlikely to have an appreciable adverse effect and that in any case the vehicle still complies with the requirements; or
- 8.1.2. Require a further test report from the technical service responsible for conducting the tests.
- 8.2. Confirmation or refusal of approval, specifying the alterations, shall be communicated by the procedure specified in paragraph 4.3 above to the Parties to the Agreement which apply this Regulation.
- 8.3. The competent authority issuing the extension of approval shall assign a series number for such an extension and inform thereof the other Parties to the 1958 Agreement applying this Regulation by means of a communication form conforming to the model in Annex 1 to this Regulation.
9. CONFORMITY OF PRODUCTION
- The conformity of production procedures shall comply with those set out in the Agreement, Schedule 1 (E/ECE/TRANS/505/Rev.3), with the following requirements:
- 9.1. Every vehicle bearing an approval mark as prescribed under this Regulation shall conform to the vehicle type approved with regard to details affecting the characteristics of the safety-belt anchorages.
- 9.2. In order to verify conformity as prescribed in paragraph 9.1 above, a sufficient number of serially-produced vehicles bearing the approval mark required by this Regulation shall be subjected to random checks.
- 9.3. As a general rule the checks as aforesaid shall be confined to the taking of measurements. However, if necessary, the vehicles shall be subjected to some of the tests described in paragraph 6. above, selected by the technical service conducting approval tests.
10. PENALTIES FOR NON-CONFORMITY OF PRODUCTION
- 10.1. The approval granted in respect of a vehicle type pursuant to this Regulation may be withdrawn if the requirement laid down in paragraph 9.1 above is not complied with or if its safety-belt anchorages failed to pass the checks prescribed in paragraph 9. above.
- 10.2. If a Contracting Party to the Agreement which applies this Regulation withdraws an approval it has previously granted, it shall forthwith so notify the other Contracting Parties applying this Regulation, by means of a communication form conforming to the model in Annex 1 to this Regulation.

11. OPERATING INSTRUCTIONS

The national authorities may require the manufacturers of vehicles registered by them to state clearly in the instructions for operating the vehicle

11.1. Where the anchorages are; and

11.2. For what types of belts the anchorages are intended (see Annex 1, item 5).

12. PRODUCTION DEFINITELY DISCONTINUED

If the holder of the approval completely ceases to manufacture a type of safety-belt anchorages approved in accordance with this Regulation, he shall so inform the authority which granted the approval. Upon receiving the relevant communication that authority shall inform thereof the other Contracting Parties to the 1958 Agreement, which apply this Regulation by means of a communication form conforming to the model in Annex 1 to this Regulation.

13. NAMES AND ADDRESSES OF TECHNICAL SERVICES RESPONSIBLE FOR CONDUCTING APPROVAL TESTS AND OF TYPE APPROVAL AUTHORITIES.

The Contracting Parties to the 1958 Agreement applying this Regulation shall communicate to the United Nations secretariat the names and addresses of the Technical Services responsible for conducting approval tests and of the Type Approval Authorities which grant approval and to which forms certifying approval or extension, or refusal or withdrawal of approval, issued in other countries, are to be sent.

14. TRANSITIONAL PROVISIONS

14.1. As from the official date of entry into force of the 06 series of amendments, no Contracting Party applying this Regulation shall refuse to grant ECE approvals under this Regulation as amended by the 06 series of amendments.

14.2. As from 2 years after the enter into force of the 06 series of amendments to this Regulation, Contracting Parties applying this Regulation shall grant ECE type approvals only if the requirements of this Regulation, as amended by the 06 series of amendments, are satisfied.

14.3. As from 7 years after the enter into force of the 06 series of amendments to this Regulation, Contracting Parties applying this Regulation may refuse to recognize approvals which were not granted in accordance with the 06 series of amendments to this Regulation. However, existing approvals of the vehicle categories which are not affected by the 06 series of amendments to this Regulation shall remain valid and Contracting Parties applying this Regulation shall continue to accept them.

14.4. For vehicles not affected by paragraph 7.1.1 above, approvals granted according to the 04 series of amendments to this Regulation shall remain valid.

14.5. For vehicles not affected by Supplement 4 to the 05 series of amendments to this Regulation the existing approvals shall remain valid, if they had been granted in compliance with the 05 series of amendments, up to its Supplement 3.

14.6. As from the official date of entry into force of Supplement 5 to the 05 series of amendments, no Contracting Party applying this Regulation shall refuse to grant approvals under this Regulation as modified by Supplement 5 to the 05 series of amendments.

14.7. For vehicles not affected by Supplement 5 to the 05 series of amendments to this Regulation the existing approvals shall remain valid, if they had been granted in compliance with the 05 series of amendments, up to its Supplement 3.

- 14.8. As from 20 February 2005 for vehicles of category M₁, Contracting Parties applying this Regulation shall grant approvals only if the requirements of this Regulation, as amended by Supplement 5 to the 05 series of amendments, are satisfied.
- 14.9. As from 20 February 2007 for vehicles of category M₁, Contracting Parties applying this Regulation may refuse to recognize approvals which were not granted in accordance with Supplement 5 to the 05 series of amendments to this Regulation.
- 14.10. As from 16 July 2006 for vehicles of category N, Contracting Parties applying this Regulation shall grant approval only if the vehicle type satisfies the requirements of this Regulation as amended by the Supplement 5 to the 05 series of amendments.
- 14.11. As from 16 July 2008 for vehicles of category N, Contracting Parties applying this Regulation may refuse to recognize approvals not granted in accordance with Supplement 5 to the 05 series of amendments to this Regulation.
- 14.12. As from the official date of entry into force of the 07 series of amendments, no Contracting Party applying this Regulation shall refuse to grant approvals under this Regulation as amended by the 07 series of amendments.
- 14.13. As from 24 months after the date of entry into force of the 07 series of amendments, Contracting Parties applying this Regulation shall grant approvals only if the requirements of this Regulation, as amended by the 07 series of amendments, are satisfied.
- 14.14. As from 36 months after the date of entry into force of the 07 series of amendments, Contracting Parties applying this Regulation may refuse to recognize approvals which were not granted in accordance with the 07 series of amendments to this Regulation.
- 14.15. Notwithstanding paragraphs 14.13 and 14.14, approvals of the vehicle categories to the preceding series of amendments to the Regulation which are not affected by the 07 series of amendments shall remain valid and Contracting Parties applying the Regulation shall continue to accept them.
- 14.16. As long as there are no requirements concerning the compulsory fitting of safety-belt anchorages for folding seats in their national requirements at the time of acceding to this Regulation, Contracting Parties may continue to allow this non-fitment for the purpose of national approval and in this case these bus categories cannot be type approved under this Regulation.
- 14.17. As from the official date of entry into force of Supplement 2 to the 07 series of amendments, no Contracting Party applying this Regulation shall refuse to grant type approval under this Regulation as amended by Supplement 2 to the 07 series of amendments.
- 14.18. As from 12 months after the official date of entry into force of Supplement 2 to the 07 series of amendments, Contracting Parties applying this Regulation shall grant type approvals only to those types of vehicle which comply with the requirements of this Regulation as amended by Supplement 2 to the 07 series of amendments.
- 14.19. Contracting Parties applying this Regulation shall not refuse to grant extensions of approvals, even if Supplement 2 to the 07 series of amendments is not fulfilled.
- 14.20. As from the official date of entry into force of the 08 series of amendments, no Contracting Party applying this Regulation shall refuse to grant approvals or refuse to accept type-approvals under this Regulation as amended by the 08 series of amendments.
- 14.21. Contracting Parties applying this Regulation shall not refuse to grant extensions of type approvals for existing types on the basis of the provisions valid at the time of the original approval.

- 14.22. Contracting Parties that apply this Regulation after the date of entry into force of the 08 series of amendments are not obliged to accept type-approvals granted in accordance with any of the preceding series of amendments to this Regulation.
- 14.23. As from the official date of entry into force of the 09 series of amendments, no Contracting Party applying this Regulation shall refuse to grant or refuse to accept UN type approvals under this Regulation as amended by the 09 series of amendments.
- 14.24. As from 1 September 2019, Contracting Parties applying this Regulation shall not be obliged to accept UN type approvals to the preceding series of amendments, first issued after 1 September 2019.
- 14.25. Until 1 September 2025, Contracting Parties applying this Regulation shall accept UN type-approvals to the preceding series of amendments, first issued before 1 September 2019.
- 14.26. As from 1 September 2025, Contracting Parties applying this Regulation shall not be obliged to accept type approvals issued to the preceding series of amendments to this Regulation.
- 14.27. Notwithstanding the transitional provisions above, Contracting Parties who start to apply this Regulation after the date of entry into force of the most recent series of amendments are not obliged to accept UN type approvals which were granted in accordance with any of the preceding series of amendments to this Regulation/are only obliged to accept UN type-approval granted in accordance with the 09 series of amendments.
- 14.28. Notwithstanding paragraph 14.26, Contracting Parties applying the UN Regulation shall continue to accept UN type approvals issued according to the preceding series of amendments to the UN Regulation, for the vehicles/vehicle systems which are not affected by the changes introduced by the 09 series of amendments.
- 14.29. Contracting Parties applying this Regulation shall not refuse to grant UN type approvals according to any preceding series of amendments to this Regulation or extensions thereof.
-

ANNEX 1

COMMUNICATION

(maximum format: A4 (210 x 297 mm))



Issued by: Name of administration

.....

- concerning: Approval granted
 Approval extended
 Approval refused
 Approval withdrawn
 Production definitively discontinued

of a vehicle type with regard to safety-belt anchorages pursuant to UN Regulation No 14

Approval No..... Extension No.....

1. Trade name or mark of the power-driven vehicle
2. Type of vehicle
3. Manufacturer's name and address
4. If applicable, name and address of manufacturer's representative
5. Designation of the type of belts and retractors authorized for fitting to the anchorages with which the vehicle is equipped:

				<i>Anchorage on */</i>	
				<i>vehicle structure</i>	<i>seat structure</i>
Front	Right-hand seat	{	lower anchorages	{	outboard
			upper anchorage		inboard
	Middle seat	{	lower anchorages	{	right
			upper anchorage		left
	Left-hand seat	{	lower anchorages	{	outboard
			upper anchorage		inboard
Rear	Right-hand seat	{	lower anchorages	{	outboard
			upper anchorage		inboard
	Middle seat	{	lower anchorages	{	right
			upper anchorage		left
	Left-hand seat	{	lower anchorages	{	outboard
			upper anchorage		inboard

* Insert in the actual position the following letter(s):
 "A" for a three-point belt,
 "B" for lap belts,
 "S" for special-type belts; in this case the type shall be stated under 'Remarks',
 "Ar", "Br" or "Sr" for belts with retractors,
 "Ae", "Be" or "Se" for belts with an energy absorption device,
 "Are", "Bre" or "Sre" for belts with retractors and energy-absorption devices on at least one anchorage.

Remarks:

6. Description of seats³

7. Description of the adjustment, displacement and locking systems either of the seat or of its parts³:

- 8. Description of seat anchorage³:
- 9. Description of particular type of safety-belt required in the case of an anchorage located in the seat structure or incorporating an energy-dissipating device:
- 10. Vehicle submitted for approval on:
- 11. Technical Service responsible for conducting approval tests:
- 12. Date of report issued by that Service:
- 13. Number of report issued by that Service:
- 14. Approval granted/extended/refused/withdrawn²
- 15. Position of approval mark on vehicle:
- 16. Place:
- 17. Date:
- 18. Signature:

19. The following documents, filed with the Type Approval Authority which has granted approval and available on request are annexed to this communication:

- Drawings, diagrams and plans of the belt anchorages and of the vehicle structure;
- photographs of the belt anchorages and of the vehicle structure;
- drawings, diagrams and plans of the seats, of their anchorage on the vehicle, of the adjustment and displacement systems of the seats and of their parts and of their locking devices³;
- photographs of the seats, of their anchorage, of the adjustment and displacement systems of the seats and of their parts, and of their locking devices³.

^{1.} Distinguishing number of the country which has granted/extended/refused/withdrawn approval (see approval provisions in the Regulation).
^{2.} Strike out what does not apply.
^{3.} Only if the anchorage is affixed on the seat or if the seat supports the belt strap.

ANNEX 2

ARRANGEMENTS OF THE APPROVAL MARK

MODEL A

(see paragraph 4.4 of this Regulation)

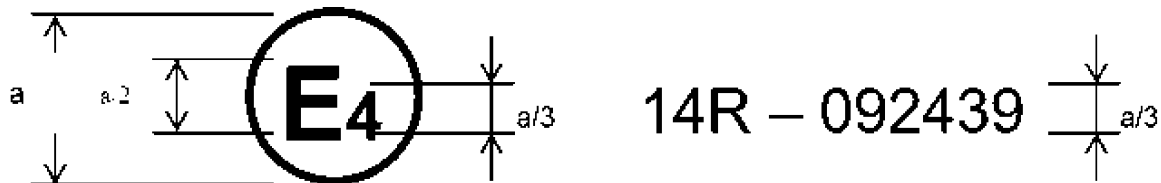

a = 8 mm min

The above approval mark affixed to a vehicle shows that the vehicle type concerned has, with regard to safety-belt anchorages, been approved in the Netherlands (E 4), pursuant to UN Regulation No 14, under the number 092439. The first two digits of the approval number indicate that UN Regulation No 14 already included the 09 series of amendments when the approval was given.

Model B

(see paragraph 4.5 of this Regulation)

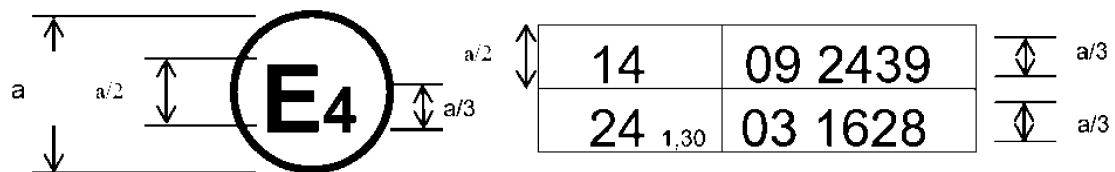

a = 8 mm min.

The above approval mark affixed to a vehicle shows that the vehicle type concerned has been approved in the Netherlands (E 4) pursuant to UN Regulations Nos 14 and 24 (*). (In the case of the latter Regulation the corrected absorption coefficient is 1,30 m⁻¹). The approval numbers indicate that on the dates on which these approvals were granted, UN Regulation No 14 included the 09 series of amendments and UN Regulation No 24 was in its 03 series of amendments.

(*) The second number is given merely as an example.

ANNEX 3

LOCATION OF EFFECTIVE BELT ANCHORAGES

Figure 1

Areas of location of effective belt anchorages

(The drawing shows one example, where the upper anchorage is fixed to the vehicle body side panel)

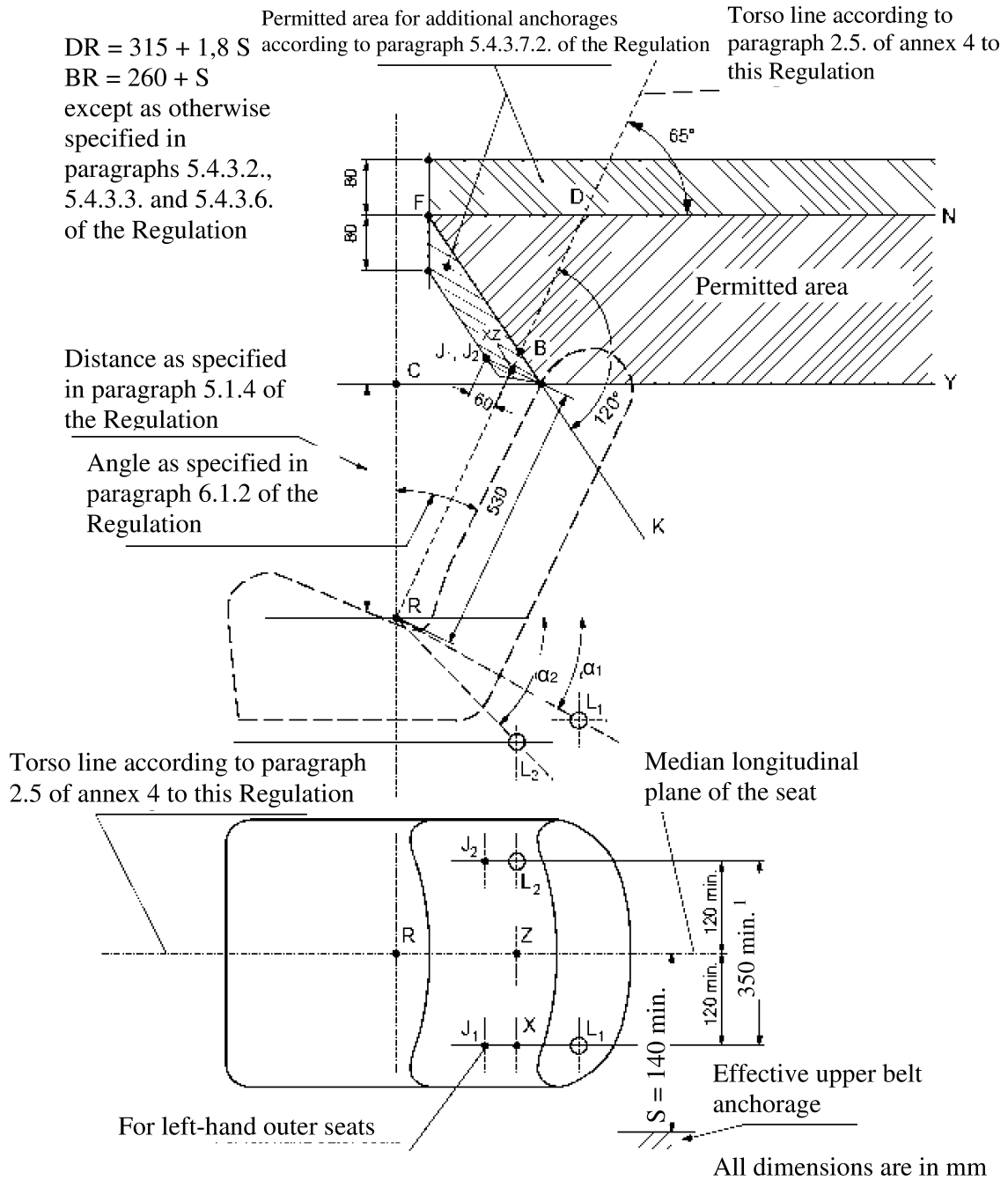

1. 240 mm minimum for the central rear seating positions of M₁ and N₁ categories of vehicles

Figure 2

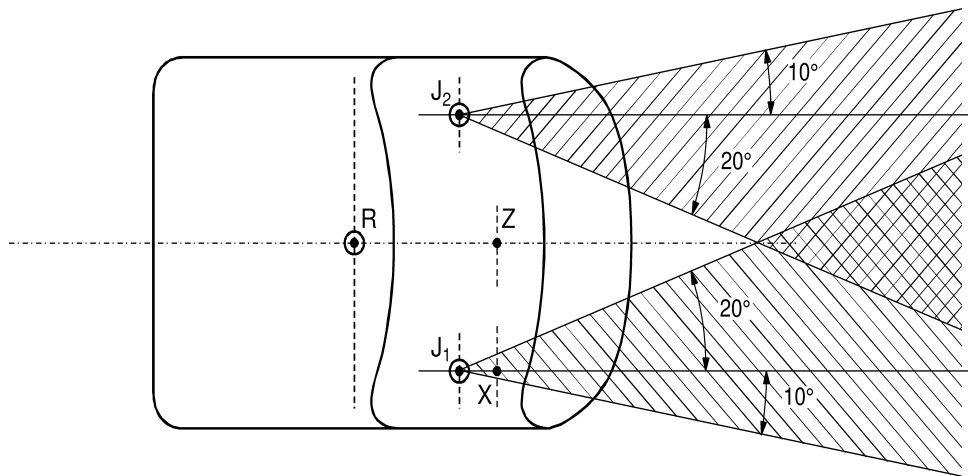
Effective upper anchorages conforming to paragraph 5.4.3.7.3 of the Regulation

ANNEX 4

Procedure for determining the "H" point and the actual torso angle for seating positions in motor vehicles ⁽¹⁾

Appendix 1 — Description of the three dimensional "H" point machine ⁽¹⁾

Appendix 2 - Three-dimensional reference system ⁽¹⁾

Appendix 3 — Reference data concerning seating positions ⁽¹⁾

—

⁽¹⁾ The procedure is described in Annex 1 to the Consolidated Resolution on the Construction of Vehicles (R.E.3) (document ECE/TRANS/WP.29/78/Rev.6)

ANNEX 5

TRACTION DEVICE

Figure 1

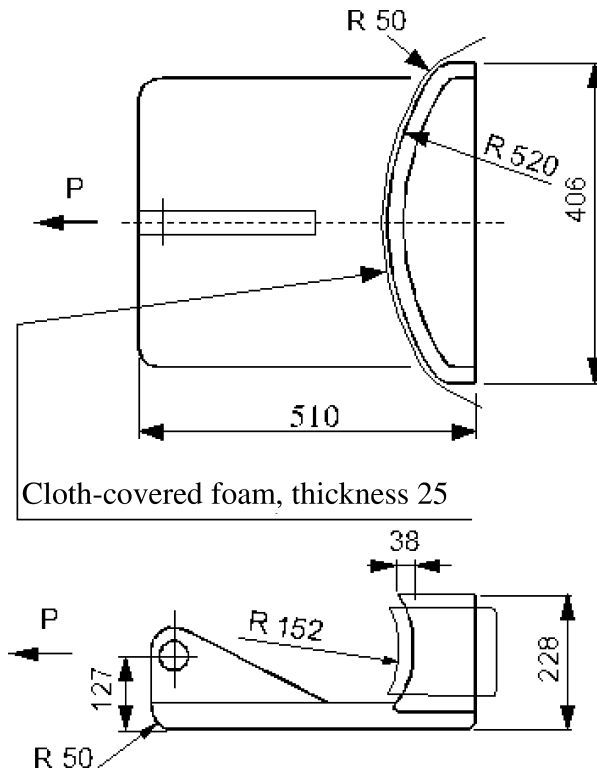

All dimensions in millimetres (mm)

Figure 1a

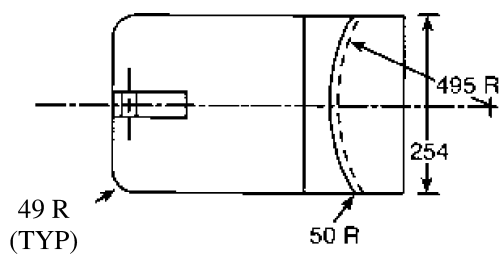

NOTES

1. Block Covered by 25 Med. Density Canvas Covered Foam Rubber

2. All Dimensions in millimetres (mm)

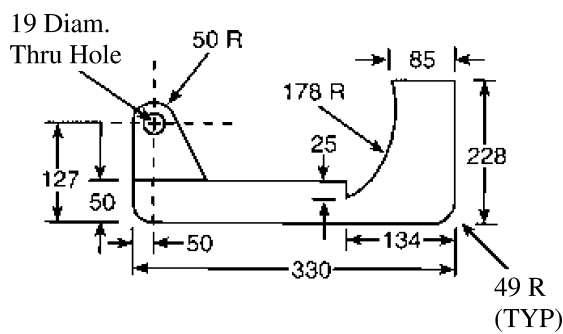

Figure 1b

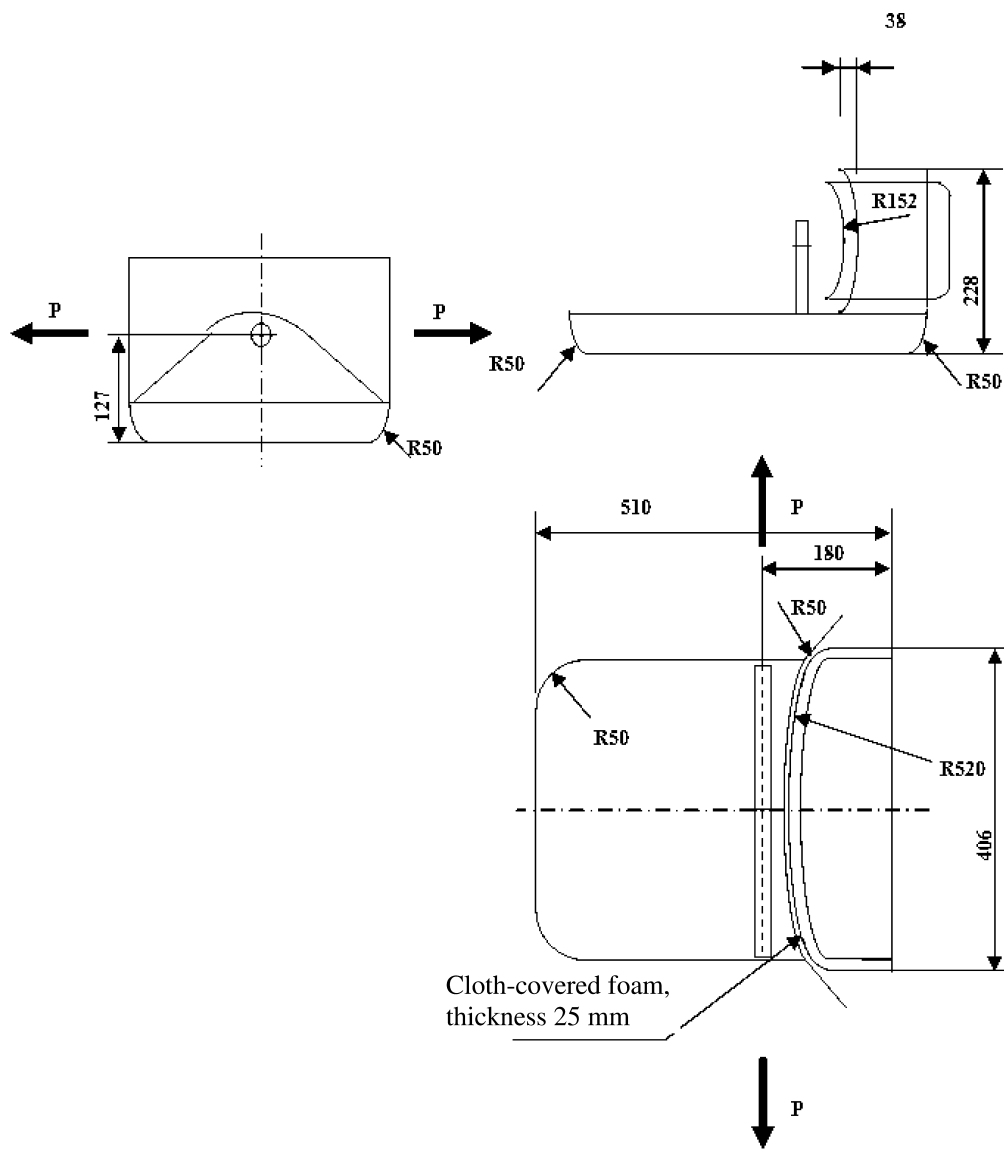
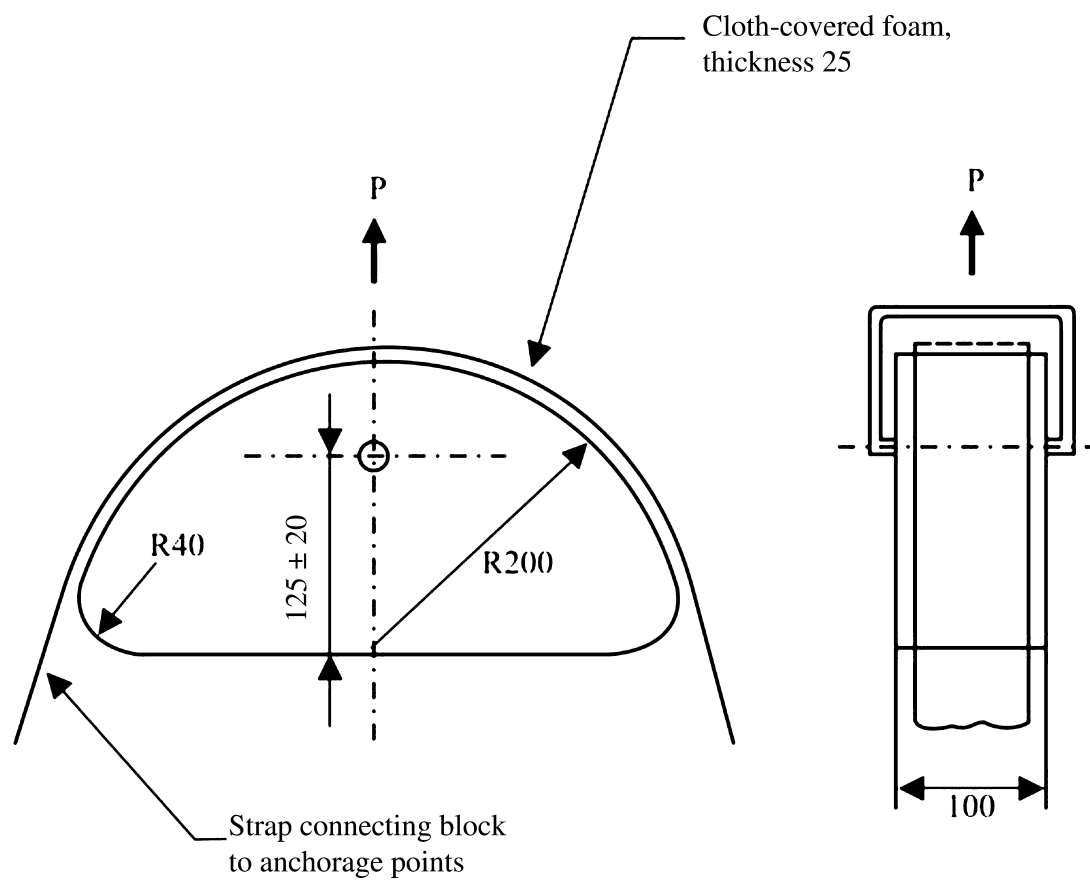

Figure 2



All dimensions are in millimetres

For the fixing of the strap the shoulder belt traction device may be modified by adding of two land edges and/or some bolts to avoid any drop off of the strap during the pull test.

Figure 3

Cloth-covered foam,
thickness 25

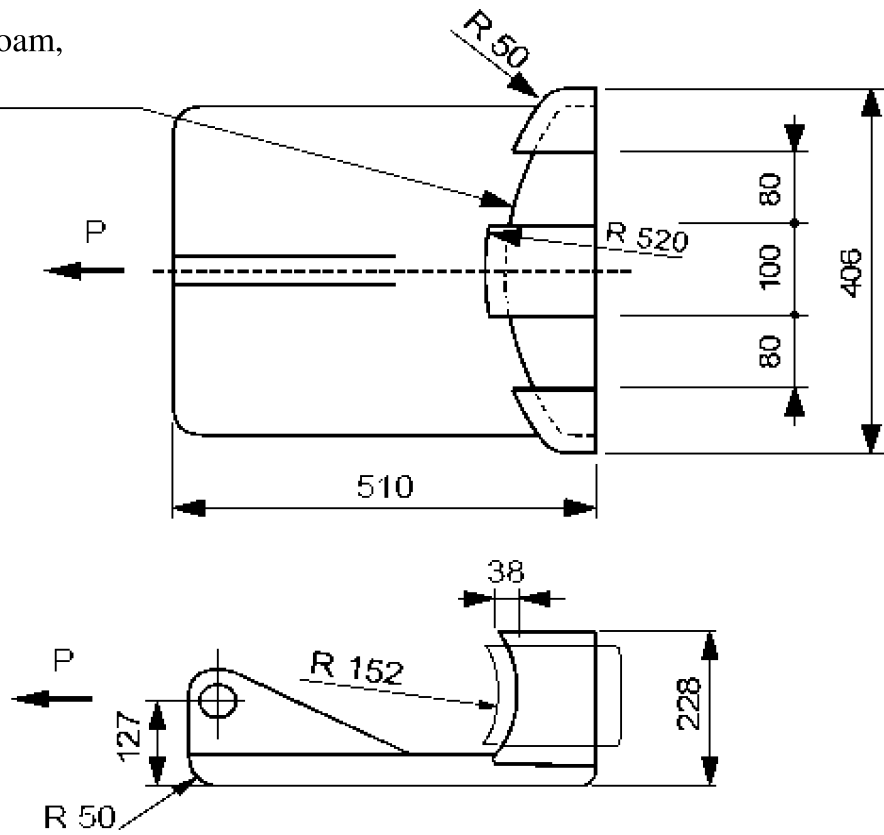

All dimensions are in millimetres

ANNEX 6

MINIMUM NUMBER OF ANCHORAGE POINTS AND LOCATION OF LOWER ANCHORAGES

Vehicle category	Forward facing seating positions				Rearward facing	Side facing
	Outboard		Centre			
	Front	Other	Front	Other		
M ₁	3	3	3	3	2	—
M ₂ ≤ 3,5 tonnes	3	3	3	3	2	—
M ₂ > 3,5 tonnes	3 ⊕	3 or 2 †	3 or 2 †	3 or 2 †	2	—
M ₃	3 ⊕	3 or 2 †	3 or 2 †	3 or 2 †	2	2
N ₁	3	3 or 2 ∅	3 or 2 *	2	2	—
N ₂ & N ₃	3	2	3 or 2 *	2	2	—

Key to symbols:

- 2: Two lower anchorages, which allow the installation of a safety-belt type B, or of safety-belts types Br, Br3, Br4m or Br4Nm, where required by the Consolidated Resolution on the Construction of Vehicles (R.E.3), Annex 13, Appendix 1.
- 3: Two lower anchorages and one upper anchorage which allow the installation of a three-point safety-belt type A, or of safety-belts types Ar, Ar4m or Ar4Nm, where required by the Consolidated Resolution on the Construction of Vehicles (R.E.3), Annex 13, Appendix 1.
- ∅: Refers to paragraph 5.3.3 (Two anchorages permitted if a seat is inboard of a passageway)
- *: Refers to paragraph 5.3.4 (Two anchorages permitted if the windscreen is outside reference zone)
- †: Refers to paragraph 5.3.5 (Two anchorages permitted if nothing is in the reference zone)
- ⊕: Refers to paragraph 5.3.7 (Special provision for the upper deck of a vehicle)

APPENDIX

LOCATION OF LOWER ANCHORAGES — ANGLE REQUIREMENTS ONLY

Seat		M ₁	Other than M ₁
Front*	buckle side (α ₂)	45° - 80°	30° - 80°
	other than buckle side (α ₁)	30° - 80°	30° - 80°
	angle constant	50° - 70°	50° - 70°
	bench — buckle side (α ₂)	45° - 80°	20° - 80°
	bench — other than buckle side (α ₁)	30° - 80°	20° - 80°
	adjustable seat with seat back angle < 20°	45° - 80° (α ₂)* 20° - 80° (α ₁)*	20° - 80°
Rear †		30° - 80°	20° - 80° Ψ
Folding	No belt anchorage required. If anchorage fitted: see angle requirements Front and Rear.		

Key to symbols:

- ‡: outboard and centre.
 *: if angle is not constant see paragraph 5.4.2.1.
 Ψ: 45° - 90° in the case of seats on M₂ and M₃ vehicles.

ANNEX 7

DYNAMIC TEST AS AN ALTERNATIVE TO THE SAFETY-BELT ANCHORAGES STATIC STRENGTH TEST

1. SCOPE

This annex describes a dynamic sled test that can be performed as an alternative to the safety-belt anchorages static strength test prescribed in paragraphs 6.3 and 6.4 of this Regulation.

This alternative can apply at the request of the car manufacturer in the case of a group of seats where all the seating positions are equipped with 3-point safety-belts to which thorax load limiter functions are associated and when the group of seats additionally comprises a seating position for which the upper safety-belt anchorage is located on the seat structure.

2. PRESCRIPTIONS

- 2.1. In the dynamic test prescribed in paragraph 3. of this annex, there shall be no rupture of any anchorage or surrounding area. A programmed rupture necessary for the functioning of the load limiter device is however permitted.

The minimum spacings for the effective lower anchorages specified in paragraph 5.4.2.5 of this Regulation, and the requirements for the effective upper anchorages specified in paragraph 5.4.3.6 of this Regulation and, when applicable, completed by the following paragraph 2.1.1, shall be respected.

- 2.1.1. For vehicles of category M₁ of a total permissible mass not exceeding 2,5 tonnes, the upper safety-belt anchorage, if attached to the seat structure, shall not be displaced forward of a transverse plane passing through the R point and point C of the seat in question (see Figure 1 of Annex 3 to this Regulation).

For vehicles other than mentioned above, the upper safety-belt anchorage shall not be displaced forward of a transverse plane inclined 10° in forward direction and passing through the R point of the seat.

- 2.2. In vehicles where such devices are used, the displacement and locking devices enabling the occupants of all seats to leave the vehicle must still be operable by hand after the test.
- 2.3. The vehicle owner's manual shall include indications that each safety-belt shall only be replaced by an approved safety-belt for the considered seating position in the vehicle, and shall in particular identify those seating positions which may only be fitted with an appropriate safety-belt equipped with a load limiter.

3. DYNAMIC TEST CONDITIONS

3.1. General conditions

The general conditions described in paragraph 6.1 of this Regulation apply to the test described in this annex.

3.2. Installation and preparation

3.2.1. Sled

The sled must be so constructed that no permanent deformation appears after the test. It must be so guided that, during the impact phase, the deviation does not exceed 5° in the vertical plane and 2° in the horizontal plane.

3.2.2. Securing of the vehicle structure

The part of the vehicle structure considered essential for the vehicle rigidity regarding the seat anchorages and the safety-belt anchorages shall be secured on the sled, according to the disposals described in paragraph 6.2 of this Regulation.

3.2.3. Restraint systems

- 3.2.3.1. The restraint systems (the complete seats, the safety-belt assemblies and the load limiter devices) shall be mounted on the vehicle structure according to the series production vehicle specifications.

The vehicle environment facing the tested seat (dashboard, seat, etc., depending on the tested seat) can be mounted on the test sled. If there were a frontal airbag, it has to be deactivated.

- 3.2.3.2. At the request of the car manufacturer and in agreement with the technical service in charge of the tests, some components of the restraint systems other than the complete seats, the safety-belt assemblies and the load limiter devices, may not be mounted on the test sled or may be replaced by components having equivalent or lower stiffness and whose dimensions are comprised in the vehicle interior fittings dimensions, provided that the tested configuration is at least as unfavourable as the series configuration regarding the forces applying to the seat and safety-belt anchorages.
- 3.2.3.3. The seats shall be adjusted as required in paragraph 6.1.2 of this Regulation, in the position for use chosen by the technical service in charge of the tests as the one giving the most adverse conditions regarding the anchorages strength and compatible with the installation of the dummies in the vehicle.
- 3.2.4. Dummies
- A dummy whose dimensions and mass are defined in Annex 8 shall be positioned on each seat and restrained by the safety-belt provided in the vehicle.
- No dummy instrumentation is required.
- 3.3. Test
- 3.3.1. The sled shall be so propelled that, during the test, its speed variation is 50 km/h. The sled deceleration shall be within the corridor specified in Annex 8 of Regulation No 16.
- 3.3.2. If applicable, the activation of additional restraining devices (preloading devices, etc., except airbags) is triggered according to the car manufacturer's indications.
- 3.3.3. It shall be checked that the safety-belt anchorages' displacement does not exceed the limits specified in paragraphs 2.1 and 2.1.1 of this annex.
-

ANNEX 8

DUMMY SPECIFICATIONS (*)

Mass	97,5 ± 5 kg
Erect sitting height	965 mm
Hip breadth (sitting)	415 mm
Hip circumference (sitting)	1200 mm
Waist circumference (sitting)	1080 mm
Chest depth	265 mm
Chest circumference	1130 mm
Shoulder height	680 mm
Tolerance on all length dimensions	±5 per cent

Remark: A sketch explaining the dimensions is given in the Figure below.

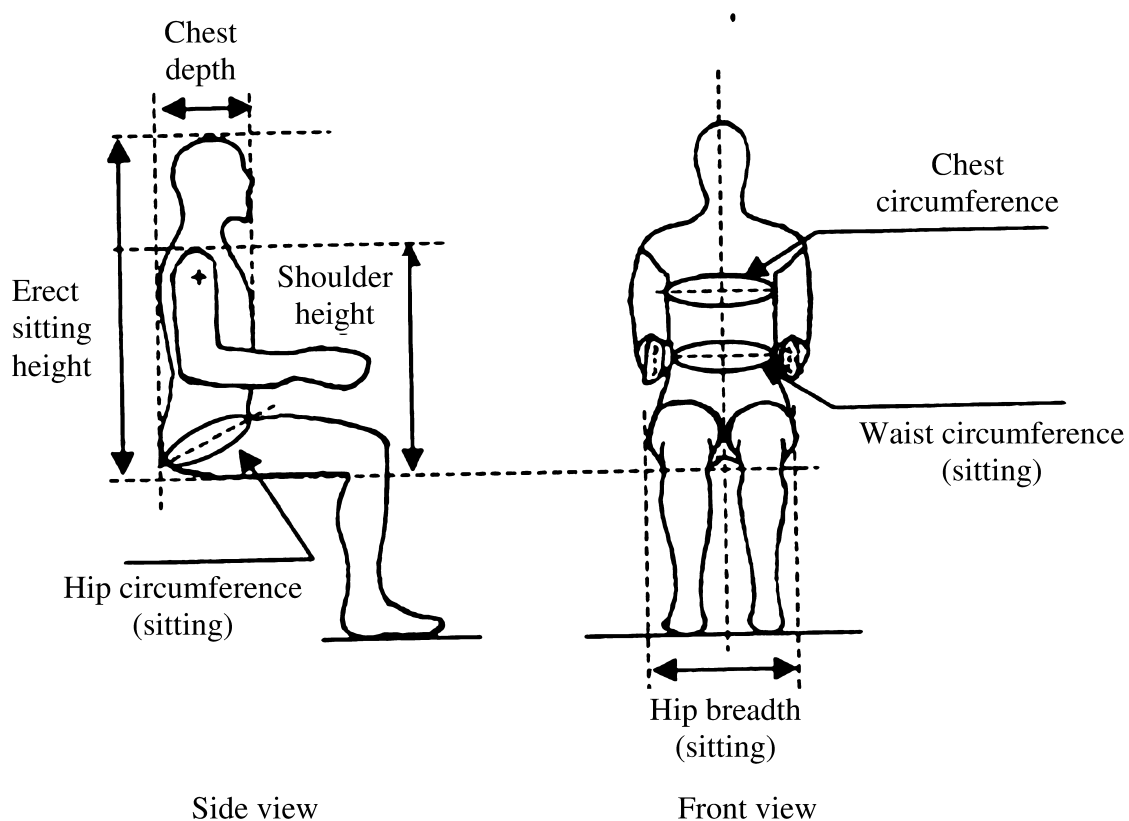

(*) Devices described in the Australian Design Rule (ADR) 4/03 and Federal Motor Vehicle Safety Standard (FMVSS) No. 208 are considered equivalent.