

This document is meant purely as a documentation tool and the institutions do not assume any liability for its contents

► **B**

COMMISSION DECISION

of 10 June 1999

Establishing the Ecological Criteria for the award of the Community Eco-label to Laundry Detergents

(notified under document number C(1999) 1522)

(Text with EEA relevance)

(1999/476/EC)

(OJ L 187, 20.7.1999, p. 52)

Corrected by:

► **C1** Corrigendum, OJ L 232, 2.9.1999, p. 34 (1999/476)

▼B

COMMISSION DECISION

of 10 June 1999

Establishing the Ecological Criteria for the award of the Community Eco-label to Laundry Detergents*(notified under document number C(1999) 1522)***(Text with EEA relevance)**

(1999/476/EC)

THE COMMISSION OF THE EUROPEAN COMMUNITIES,

Having regard to the Treaty establishing the European Community,

Having regard to Council Regulation (EEC) No 880/92 of 23 March 1992 on a Community Eco-label award scheme ⁽¹⁾, and in particular the second subparagraph of Article 5(1) thereof,

- (1) Whereas, by Decision 95/365/EC ⁽²⁾, the Commission established ecological criteria for the award of the Community eco-label to laundry detergents, which, according to Article 3 thereof, expired on 25 July 1998;
- (2) Whereas it is appropriate to adopt a new Decision for the product group 'laundry detergents' and establish criteria for this product group, which will be valid for a period of three years;
- (3) Whereas it is appropriate to revise the criteria that were established by Decision 95/365/EC in order to reflect the developments in the market;
- (4) Whereas the first subparagraph of Article 5(1) of Regulation (EEC) No 880/92 provides that the conditions for the awards of the Community Eco-label shall be defined by product group;
- (5) Whereas Article 10(2) of Regulation (EEC) No 880/92 states that environmental performance of a product shall be assessed by reference to the specific criteria for product groups;
- (6) Whereas Article 4(2)(a) of Regulation (EEC) No 880/92 states that an eco-label shall not be awarded to products which are substances or preparations classified as dangerous in accordance with Council Directive on the approximation of laws, regulations and administrative provisions relating to the classification, packaging and labelling of dangerous substances 67/548/EEC ⁽³⁾ as last amended by Commission Directive 98/98/EC ⁽⁴⁾ and Council Directive 88/379/EEC ⁽⁵⁾, as last amended by Commission Directive 96/65/EEC ⁽⁶⁾, but it may be awarded to products containing such substances or preparations in so far as they meet the objectives of the Community eco-label award scheme;
- (7) Whereas laundry detergents contain substances or preparations classified as dangerous in accordance with the abovementioned Directives;
- (8) Whereas the ecological criteria established by this Decision include, in particular, hurdles and scores limiting to a minimum the content of substances and preparations classified as dangerous in the detergents which may be awarded an eco-label;
- (9) Whereas detergents complying with these criteria have therefore a reduced environmental impact and meet the objectives of the Community eco-label award scheme;

⁽¹⁾ OJ L 99, 11.4.1992, p. 1.⁽²⁾ OJ L 217, 13.9.1995, p. 14.⁽³⁾ OJ 196, 16.8.1967, p. 1⁽⁴⁾ OJ L 355, 30.12.1998, p. 1.⁽⁵⁾ OJ L 187, 16.7.1988, p. 14.⁽⁶⁾ OJ L 265, 18.10.1996, p. 15.

▼B

- (10) Whereas the Commission has adopted the recommendation of 22 July 1998 concerning good environmental practice for household laundry detergents ⁽¹⁾;
- (11) Whereas in accordance with Article 6 of Regulation (EEC) No 880/92 the Commission has consulted the principal interest groups within a consultation forum;
- (12) Whereas the measures provided for in this Decision are in accordance with the opinion of the committee set up under Article 7 of Regulation (EEC) No 880/92,

HAS ADOPTED THIS DECISION:

Article 1

The product group 'laundry detergents' means all laundry detergents, in powder, liquid or any other form; for the washing of textiles, and which are intended to be used principally in household washing machines.

Article 2

The environmental performance and the fitness for use of the product group, as defined in Article 1, shall be assessed by reference to the specific ecological and performance criteria set out in the Annex and Appendices I Part A, I Part B, II, III and IV.

Article 3

The product group definition and the criteria for the product group shall be valid for a period of three years from the first day on which this Decision enters into force.

Article 4

For administrative purposes, the code number assigned to the product group shall be '006'.

Article 5

This Decision is addressed to the Member States.

⁽¹⁾ OJ L 215, 1.8.1998, p. 73.



ANNEX

FRAMEWORK

The general requirements established by Regulation (EEC) No 880/92 on a Community eco-label award scheme and the following specific criteria shall apply for the awarding of an eco-label to laundry detergents and must be complied with during the entire period covered by the contract concerning the terms of use of the label.

The competent bodies are recommended to take into account the implementation of recognised environmental management schemes, such as EMAS or ISO 14001, when assessing applications and monitoring compliance with the criteria in this Annex.

These criteria aim at promoting:

- the reduction of water pollution both by reducing the quantity of detergent used and by limiting the quantity of harmful ingredients
- the minimisation of waste production by reducing the amount of primary packaging and promoting its reusability and/or recyclability
- the reduction of energy use by promoting low temperature detergents.

Additionally, the criteria enhance the consumers' environmental awareness.

1. FUNCTIONAL UNIT AND REFERENCE DOSAGE

1.1. Functional unit

The functional unit is expressed in g/wash (grams per wash). For heavy-duty detergents this is related to the dosage per 4,5 kg load (dry textiles) and for low-duty detergents to the dosage per 2,5 kg load (dry textiles) in the washing machine.

1.2. Reference dosage

The dosage recommended by the manufacturer to consumers for the water hardness of 2,5 mmol CaCO₃/l and 'normally soiled' textiles is taken as the reference dosage for:

- the calculation of the ecological criteria,
- and
- the test of washing performance.

If the water hardness of 2,5 mmol CaCO₃/l is not relevant in the Member States in which the detergent is marketed, the applicant shall specify the dosage used as the reference.

2. ECOLOGICAL CRITERIA ON INGREDIENTS AND PACKAGING

2.1. Ecological criteria on ingredients

The following parameters are considered:

- total chemicals (TC),
- critical dilution volume-toxicity (CDV tox),
- phosphates (as STPP),
- insoluble inorganics (II)
- soluble inorganics (SI)
- non-biodegradable organics (aerobic) (aNBD0)
- non biodegradable organics (anaerobic) (anNBD0)
- biological oxygen demand (BOD).

Appendix II presents the definition of parameters used in the calculation. These parameters are calculated and expressed as g/wash or l/wash as appropriate. They are aggregated and assessed as a whole, according to the approach presented in this document.

Scoring/weighting factors

The following table summarises the selected criteria, their exclusion hurdles, their weighting factors and the maximum achievable scoring result. The scoring system formulae to be used to calculate the score in respect of each criterion are presented in point 2.3.

▼B

Laundry detergents scoring/weighting calculation system

Score	4	3	2	1	Exclusion hurdle	Weighting	Sum
Criterion							
Total chemicals	60	70	80	90	110	3	12
Critical dilution volume, tox	1 500	3 500	5 500	7 500	10 000	8	32
Phosphates (as STPP)	0	7,5	15	22,5	30	2	8
Insoluble inorganics	10	15	20	25	30	0,5	2
Soluble inorganics	10	25	40	55	70	0,5	2
NBDO (aerobic)	1	2	3	4	8	1	4
NBDO (anaerobic)	1	4	7	10	15	1,5	6
BOD	20	40	60	80	130	2	8
Total							74
Minimum score required	45						

Note: All values are expressed in g/wash, except the CDV_{tox} which is expressed in l/wash.

2.2. Pass/fail level for awarding the eco-label

The sum of the scores related to the eight criteria concerning the ingredients shall be equal to or greater than 45.

Hurdle values shall not be exceeded on any criterion. The product shall also be in compliance with the criteria set out in other parts of this Annex.

2.3. Calculations related to ecological criteria on ingredients

Detergent ingredient database (DID-list)

Appendix I, Part A presents the detergent ingredients database (DID-list) which contains the most widely used ingredients used in detergents formulation. It shall be used for calculations of the criteria concerning ingredients.

Data on the loading factor, toxicity, non-biodegradability (aerobic), non biodegradability (anaerobic), soluble/insoluble inorganics and biological oxygen demand (BOD), are listed for the major detergent ingredients in Appendix I, Part A and these data shall be used for the calculations concerning these ingredients.

The criteria:

- total chemicals
- phosphates (as STPP)
- soluble/insoluble inorganics
- non-biodegradable (aerobic/anaerobic)
- BOD

shall be calculated for each ingredient by considering the dosage per wash, water content and mass percentage and shall be totalled for each product formulation.

The criterion on critical dilution volume toxicity is calculated for each ingredient (i) of the detergent formulation by the following equation:

$$CDV_{tox}(\text{ingredient } i) = \frac{\text{weight/wash } (i) \times \text{loading factor } (i)}{\text{long term effect } (i)} \times 1\,000$$

Procedure for the calculation of scores

For the calculation of scores, the following equations shall be used:

▼ B**Total chemicals (TC)**

If TC > 110 g/wash	then	EXCLUSION
If TC ≤ 90 g/wash	then	Score = 10 – TC /10
If 110 ≥ TC > 90 g/wash	then	Score = 0
If TC ≤ 60 g/wash	then	Score = 4

Critical Dilution Volume tox (CDV_{TOX}):

If CDV_{TOX} > 10 000 l/wash	then	EXCLUSION
If CDV_{TOX} ≤ 7 500 l/wash	then	Score = 4,75 – CDV_{TOX} /2 000
If 10 000 ≥ CDV_{TOX} > 7 500 l/wash	then	Score = 0
If CDV_{TOX} ≤ 1 500 l/wash	then	Score = 4

Phosphates (P)

If P > 30 g/wash	then	EXCLUSION
If P ≤ 22,5 g/wash	then	Score = 4 – P /7,5
If 30 ≥ P > 22,5 g/wash	then	Score = 0

Insoluble inorganics (II):

If II > 30 g/wash	then	EXCLUSION
If II ≤ 25 g/wash	then	Score = 6 – II /5
If 30 ≥ II > 25 g/wash	then	Score = 0
If II ≤ 10 g/wash	then	Score = 4

Soluble inorganics (SI):

If SI > 70 g/wash	then	EXCLUSION
If SI ≤ 55 g/wash	then	► C1 Score = 4,66 – SI /15 ◀
If 70 ≥ SI > 55 g/wash	then	Score = 0
If SI ≤ 10 g/wash	then	Score = 4

Aerobic non-biodegradable organics (aNBDO):

If aNBDO > 8 g/wash	then	EXCLUSION
If aNBDO ≤ 4 g/wash	then	Score = 5 – aNBDO
If 8 ≥ aNBDO > 4 g/wash	then	Score = 0
If aNBDO ≤ 1 g/wash	then	Score = 4

Anaerobic non-biodegradable organics (anNBDO):

If anNBDO > 15 g/wash	then	EXCLUSION
If anNBDO ≤ 10 g/wash	then	Score = 4,34 – anNBDO /3
If 15 ≥ anNBDO > 10 g/wash	then	Score = 0
If anNBDO ≤ 1 g/wash	then	Score = 4

▼ B**BOD (BOD):**

If BOD > 130 g/wash	then	EXCLUSION
If BOD ≤ 80 g/wash	then	Score = 5 – BOD /20
If 130 ≥ BOD > 80 g/wash	then	Score = 0
If BOD ≤ 20 g/wash	then	Score = 4

New additional ingredients

In the case of new chemicals or additional ingredients which are not listed in the detergent ingredient database the approach described below and in Appendix I, Part B shall be followed.

- experimental data shall be submitted by the applicant to the competent body,
- the data on soluble/insoluble inorganics, on anaerobic biodegradability (based on Ecetoc test No 28, June 1988) and biological oxygen demand (BOD) shall be provided,
- all the available documentation shall be provided concerning the data which are presented on biodegradation, removal, long-term effects (NOEC data) on fish, *daphina magna*, algae,
- the reference for the relevant tests shall be the appropriate Annexes to Directive 67/548/EEC.

The provisions of Appendix I, Part B shall apply, as appropriate.

In particular, if complete data concerning long-term effects (NOEC) are not available, the relevant simplified procedures described in Appendix I, Part B shall be applied.

Where appropriate, alternative data may be accepted if their equivalence is accepted by the competent body assessing the application.

2.4. Other ecological criteria concerning ingredients

Certain specific ingredients shall not exceed a maximum content in the detergent formulation or shall not be used, as specified below:

- (a) the total weight of ingredients⁽¹⁾, which are or may be classified as dangerous for aquatic environment and assigned the risk phrase R50 (very toxic for aquatic organisms) according to Directive 67/548/EEC shall not be higher than 10 g/wash;
- (b) the total weight of ingredients which are or may be classified as dangerous for the environment and be assigned the risk phrase R50 (very toxic for aquatic organisms) and R53 (may cause long-term adverse effects on the aquatic environment) according to Directive 67/548/EEC shall not be higher than 0,25 g/wash;
- (c) phosphonates shall not exceed 1 g/wash;
- (d) surfactants from the alkylphenoethoxylates family (APEO), perfumes containing the aromatic nitro compounds referred to in Appendix II, the complex formation agent EDTA and ingredients classified as carcinogenic, toxic to reproduction and mutagenic according to Directive 67/548/EEC shall not be used.

2.5. Ecological criteria on product packaging

Only primary packaging is considered. The packaging of the detergent shall consist of lightweight packaging or a container (cardboard/plastic box or plastic bottle).

If the detergent is provided in a container (box or bottle), the manufacturer shall provide refills.

The weight of the lightweight packaging or the refill packaging shall not exceed 1,7 g/wash.

The weight of the container shall not exceed 7 g/wash.

The cardboard packaging shall be 80 % recycled packaging and the plastic packaging shall be labelled according to ISO 1043.

⁽¹⁾ 'Ingredients' means either substances or preparations.



3. PERFORMANCE CRITERIA

The product shall be compared in its washing performance with reference detergents of the same type according to the EU eco-detergents performance test.

The product shall fulfil the minimum requirements set in this test.

4. TESTING

4.1. Test on purity of enzymes to verify the absence of production organisms

A test on the purity of enzymes has to be performed on enzymes that are produced by biotechnological processes and used in laundry detergents applying for the eco-label. It is the aim of this test to assure that production organisms are not contained in the final enzyme preparation. The growth of micro-organisms is tested together with specified antibiotics. The test procedure on purity shall ensure that no production organism is detected in a 20 ml standard test sample of the final enzyme product.

4.2. Testing laboratories

The testing shall be performed at the expense of the applicant by laboratories that meet the general requirements laid out in the EN 45001 standards or any equivalent systems.

5. CONSUMER INFORMATION

5.1. Information on packaging

The following information shall appear on or in the packaging:

‘ENVIRONMENTALLY FRIENDLY WASHING MEANS:

Step 1: pre-sort laundry (e.g. by colour, degree of soiling, type of fibre)

Step 2: wash with full load

Step 3: avoid using too much detergent, follow dosage instructions

Step 4: choose low-temperature washing cycles.’

More information on the detergent shall be made available on request. For this purpose, a sentence should appear on the packaging saying that if the consumer wants to know more about the detergent, he should call (or write to) the consumer department of the company or the retailer.

In order to encourage the consumer to avoid using too much detergent and to follow dosage instruction, a dosage device (cup) showing a scale of at least 10 ml steps shall be available on request if it is not included in the packaging.

The following information shall appear on the packaging:

‘This product has been awarded the EU eco-label because it contributes to the reduction of water pollution, waste production and energy consumption.

For more information about the EU eco-label, visit the internet website: <http://europa.eu.int/ecolabel>’.

5.2. Dosage instructions

Dosage recommendations shall appear on the product packaging, together with a recommendation to the consumer to contact his water supplier or local authority in order to find out the degree of hardness of his tap water.

The recommended dosages must be specified for ‘normally’ and ‘heavily’ soiled textiles and the various water hardness ranges relevant for the countries concerned and referred as appropriate to the weight of textile. If dosage instructions are given by way of dosage device, the volume of the device (in ml) should also appear clearly on the packaging.

The washing efficiency shall be indicated and relate to ‘normally soiled’ and the various water hardness ranges considered.

The dosage recommendations between water hardness range 1 (soft) — ‘normally soiled’ and highest water hardness range (3 or 4) — ‘heavily soiled’ may not differ by more than a factor of 2.

The reference dosage used for the washing performance test and for the calculation of ecological criteria shall be the same as the recommended dosage for

▼B

'normally soiled' and the water hardness range corresponding to 2,5 mmol CaCO₃/l in the Member State in which the test has been performed.

If only water hardness lower than 2,5 mmol CaCO₃/l are included in the recommendations, the maximum dosage recommended for 'normally soiled' shall be lower than the reference dosage mentioned in the previous paragraph.

5.3. Information and labelling of ingredients

Commission recommendation 89/542/EEC ⁽¹⁾ of 13 September 1989 concerning the labelling of detergents and cleaning agents must be applied:

The following groups of ingredients shall be labelled independently from their mass content:

- *Enzymes*: indication of enzymes (e.g. protease, lipase).
- *Preservation agents*: characterisation and labelling according to IUPAC nomenclature.
- *Disinfectants*: characterisation and labelling according to IUPAC nomenclature.

If the product contains perfumes, it shall be indicated on the packaging.

⁽¹⁾ OJ L 291, 10.10.1989, p. 55.

Appendix I

DETERGENT INGREDIENTS DATABASE AND APPROACH TO BE FOLLOWED FOR INGREDIENTS NOT LISTED IN THE DATABASE

A. The data given below on the most commonly used detergent ingredients shall be used for the calculation of the ecological criteria (see following table):

DETERGENT INGREDIENTS DATABASE

DID No	Ingredients	Toxicity		Loading factor	Anaerobic Non-biodegradable	Aerobic Non-biodegradable	Soluble Inorganics	Insoluble Inorganics	THOD
		NOEC Measured	LTE						
Anionic surfactants									
1	C 10-13 LAS (NA Ø 11,5-11,8, C 14 < 1 %)	0,3	0,3	0,05	Y, CF = 0,75	0	0	0	2,3
2	Other LAS (C 14 > 1 %)	0,12	0,12	0,05	Y, CF = 1,5	0	0	0	2,3
3	C 14/17 Alkylsulfonate	0,27	0,27	0,03	Y, CF = 0,75	0	0	0	2,5
4	C 8/10 Alkylsulphate	EC50 = 2,9	0,15	0,02	0	0	0	0	1,9
5	C 12/15 AS	0,1	0,1	0,02	0	0	0	0	2,2
6	C 12/18 AS	LC50 = 3	0,15	0,02	0	0	0	0	2,3
7	C 16-18 FAS	0,55	0,55	0,02	0	0	0	0	2,5
8	C 12/15 A 1-3 EO sulphate	0,15	0,15	0,03	0	0	0	0	2,1
9	C 16/18 A 3-4 EO sulphate	No valid data	0,1	0,03	0	0	0	0	2,2
10	C 8-Dialkylsulfosuccinate	LC50 = 7,5	0,4	0,5	Y, CF = 1,5	0	0	0	2
11	C 12/14 sulpho-fat-acid methylester	EC50 = 5	0,25	0,05	Y, CF = 0,75	0	0	0	2,1
12	C 16/18 sulpho-fat-acid methylester	0,15	0,15	0,05	Y, CF = 0,75	0	0	0	2,3
13	C 14/16 alpha olefine sulphonate	LC50 = 2,5	0,13	0,05	Y, CF = 0,75	0	0	0	2,3
14	C 14-18 alpha olefin sulphonate	LC50 = 1,4	0,07	0,05	Y, CF = 2,0	0	0	0	2,4
15	C 12-22 SOAPS	ECO = 1,6	1,6	0,05	0	0	0	0	2,9
Non-ionic surfactants									
16	C 9/11 A > 3-6 EO lin. or mono br.	EC50 = 3,3	0,7	0,03	0	0	0	0	2,4
17	C 9/11 A > 6-9 EO lin. or mono br.	EC50 = 5,4	1,1	0,03	0	0	0	0	2,2
18	C 12-15 A 2-6 EO lin. or mono br.	0,18	0,18	0,03	0	0	0	0	2,5
19	C 12-15 (Avg. C < 14) A > 6-9 EO lin. or mono br.	0,24	0,24	0,03	0	0	0	0	2,3
20	C 12-15 (Avg. C > 14) A > 6-9 EO lin. or mono br.	0,17	0,17	0,03	0	0	0	0	2,3

DID No	Ingredients	Toxicity		Loading factor	Anaerobic Non-biodegradable	Aerobic Non-biodegradable	Soluble Inorganics	Insoluble Inorganics	THOD
		NOEC Measured	LTE						
21	C 12-15 A > 9-12 EO	LC50 = 0,8	0,3	0,03	0	0	0	0	2,2
22	C 12-15 A > 20-30 EO	EC50 = 13	0,65	0,05	0	0	0	0	2
23	C 12-15 A > 30 EO	LC50 = 130	6,5	0,75	0	0	Y	0	0*(1)
24	C 12/18 A 0-3 EO	No data	0,01	0,03	0	0	0	0	2,9
25	C 12-18 A 9 EO	0,2	0,2	0,03	0	0	0	0	2,4
26	C 16/18 A 2-6 EO	0,03	0,03	0,03	0	0	0	0	2,6
27	C 16/18 A > 9-12 EO	LC50 = 0,5	0,05	0,03	0	0	0	0	2,3
28	C 16/18 A 20-30 EO	EC50 = 18	0,36	0,05	0	0	0	0	2,1
29	C 16/18 A > 30 EO	LC50 = 50	2,5	0,75	0	Y	0	0	0*(1)
30	C 12/14 Glucose Amide	4,3	4,3	0,03	0	0	0	0	2,2
31	C 16/18 Glucose Amide	0,116	0,116	0,03	0	0	0	0	2,5
32	C 12/14 Alkylpolyglucoside	1	1	0,03	0	0	0	0	2,3
	Amphoteric surfactants								
33	C 12-15 Alkyldimethylbetaine	0,03	0,03	0,05	Y, CF = 2,5	0	0	0	2,9
34	Alkyl (C 12-18) amidopropylbetaine	0,03	0,03	0,05	Y, CF = 2,5	0	0	0	2,8
	Suds controllers								
35	Silicone	EC50 = 241	4,82	0,4	Y, CF = 0,75	Y	0	0	0,0
36	Paraffin	No data	100	0,4	0	Y	0	0	0*(1)
	Fabric softening								
37	Glycerol	LC50 > 5-10 gl	1 000	0,13	0	0	0	0	1,2
	Builders								
38	Phosphate, as STPP		1 000	0,6	0	0	Y	0	0,0
39	Zeolite A	120	120	0,05	0	0	0	Y	0,0
40	Citrate	EC50 = 85	85	0,07	0	0	0	0	0,6
41	Polycarboxylates and related derivatives	124	124	0,4	Y, CF = 0,1	Y	0	0	0*(1)
42	Clay	1 000	1 000	0,05	0	0	0	Y	0,0
43	Carbonate/bicarbonate	LC50 = 250	250	0,8	0	0	Y	0	0,0
44	Fatty acid (C > = 14)	EC0 = 1,6	1,6	0,05	0	0	0	0	2,9

DID No	Ingredients	Toxicity		Loading factor	Anaerobic Non-biodegradable	Aerobic Non-biodegradable	Soluble Inorganics	Insoluble Inorganics	THOD
		NOEC Measured	LTE						
45	Silicate/disilicate	EC50 > 1 000	1 000	0,8	0	0	Y	0	0,0
46	NTA	19	19	0,13	0	0	0	0	0,6
47	Polyaspartic acid, Na salt	125	12,5	0,13	Y, CF=0,1	0	0	0	1,2
	Bleaching								
48	Perborate mono (as borate)	1-10	6	1	0	0	Y	0	0,0
49	Perborate tetra (as borate)	1-10	6	1	0	0	Y	0	0,0
50	Percarbonate (see carbonate)	LC50 = 250	250	0,8	0	0	Y	0	0,0
51	TAED	EC0 = 500	EC0 = 500	0,13	0	0	0	0	2,0
	Solvents								
52	C 1-C 4 alcohols	LC50 = 8 000	100	0,13	0	0	0	0	2,3
53	Monoethanolamine	0,78	0,78	0,13	0	0	0	0	2,7
54	Diethanolamine	0,78	0,78	0,13	0	0	0	0	2,3
55	Triethanolamine	0,78	0,78	0,13	0	0	0	0	2
	Miscellaneous								
56	Polyvinylpyrrolidon (PVP/PVNO/PVPVT)	EC50 > 100	100	0,75	Y, CF = 0,1	Y	0	0	0* (!)
57	Phosphonates	7,4	7	0,4	Y, CF = 0,5	Y	0	0	0* (!)
58	EDTA	LOEC = 11	11	1	Y, CF = 0,1	Y	0	0	0* (!)
59	CMC	LC50 > 250	250	0,75	Y, CF = 0,1	Y	0	0	0* (!)
60	Na Sulphate	EC50 = 2 460	1 000	1	0	0	Y	0	0,0
61	Mg Sulphate	EC50 = 788	800	1	0	0	Y	0	0,0
62	Na Chloride	EC50 = 650	650	1	0	0	Y	0	0,0
63	Urea	LC50 > 10 000	100	0,13	0	0	0	0	2,1
64	Maleic acid	LC50 = 106	2,1	0,13	0	0	0	0	0,8
65	Malic acid	LC50 = 106	2,1	0,13	0	0	0	0	0,6
66	Ca formiate		100	0,13	0	0	0	0	2,0
67	Silica		100	0,05	0	0	0	Y	0,0
68	Higg MW polymers PEG > 4 000		100	0,4	0	Y	0	0	0* (!)
69	Low MW polymers PEG < 4 000		100	0,13	0	0	0	0	1,1



DID No	Ingredients	Toxicity		Loading factor	Anaerobic Non-biodegradable	Aerobic Non-biodegradable	Soluble Inorganics	Insoluble Inorganics	THOD
		NOEC Measured	LTE						
70	Cumene sulphonate	LC50 = 66	6,6	0,13	Y, CF = 0,25	0	0	0	1,7
71	Xylene sulphonate	LC50 = 66	6,6	0,13	Y, CF = 0,25	0	0	0	1,6
72	Toluene sulphonate	LC50 = 66	6,6	0,13	Y, CF = 0,25	0	0	0	1,4
73	Na-/Mg-/KOH		100	1	0	0	Y	0	0,0
74	Enzymes	LC50 = 25	25	0,13	0	0	0	0	2,0
75	Perfume mixtures as used	LC50 = 2-10	0,02	0,1	Y, CF = 3,0	Y	0	0	0* (1)
76	Dyes	LC50 = 10	0,1	0,4	Y, CF = 3,0	Y	0	0	0* (1)
77	Starch	no data	250	0,1	0	0	0	0	0,97
78	Zn Phthalocyanine sulphonate	NOEC = 0,16	0,016	0,07 (2)	Y, CF = 2,5	Y	0	0	0* (1)
79	Anionic polyester (Soil release polyester)	NOEC = 310	310	0,4	Y, CF = 0,1	Y	0	0	0* (1)
80	Iminodisuccinate	23	2,3	0,13	Y, CF = 0,25	0	0	0	1,1
Optical brighteners (FWA)									
81	FWA 1 (3)	LC0 = 10	1,0	0,4	Y, CF = 1,5	Y	0	0	0* (1)
82	FWA 5 (4)	3,13	3,13	0,4	Y, CF = 0,5	Y	0	0	0* (1)
Additional ingredients									
83	Alkyl Aminoxides (C 12-18)	EC0 = 0,08	0,08	0,05	Y, CF = 2,5	0	0	0	3,2
84	Glycereth (C 6-17) EO cocoate	EC50 = 32	1,6	0,05	0	0	0	0	2,1
85	Phosphate esters (C 12-18)	EC50 = 38	1,9	0,05	Y, CF = 0,25	0	0	0	2,3

(1) 0* = THOD for aerobic non-degradable organic substances is set to zero.

(2) Rapid photodegradation.

(3) FWA 1 = Disodium 4,4'-bis (4-amino-5-morpholino-1,3,5-triazin-2-yl) amino stilbene-2,2'-disulfonate.

(4) FWA 5 = Disodium 4,4'-bis (2-sulfostyryl) biphenyl.

Notes:

Y = Yes

CF = Correction factor, to be applied to the dosage expressed in g/wash

0 = not to be used

NOEC = Non-observed measured concentration

LTE = Long-term effect

THOD = Theoretical oxygen demand

▼B**B. The following approach shall apply, as appropriate in the case of ingredients that are not listed on the DID list***Aquatic toxicity*

The lowest validated long-term effect (LTE) data on fish, *daphnia magna* or algae shall be considered for the calculation of the critical dilution volume criterion (toxicity).

In cases where data on homologues and/or QSARs (Quantitative structure activity relationships) are used, a correction could be considered for the finally selected LTE data.

In the absence of LTE data the following procedure has to be applied in order to estimate the LTE data by using the specified uncertainty factor (UF) on the data of the most sensitive species:

Non-surfactants

DATA AVAILABLE	UF TO BE USED
At least two acute LC ₅₀ on fish or <i>daphnia</i> or algae	100
1 NOEC on fish, <i>daphnia</i> or algae	10
2 NOEC on fish, <i>daphnia</i> or algae	5
3 NOEC on fish, <i>daphnia</i> or algae	1
	Take lowest validated NOEC

Deviation from this rule may be admitted by the competent body assessing the application if evidence can be provided that lower factors or data can be scientifically justified.

Surfactants

DATA AVAILABLE	UF TO BE USED
At least two NOEC on fish or <i>daphnia</i> or algae	1 (lowest NOEC)
1 NOEC on fish <i>daphnia</i> or algae	1 (NOEC-if species is most sensitive in acute toxicity)
3 LC ₅₀ on fish <i>daphnia</i> or algae	20 (lowest LC ₅₀)
At least one LC ₅₀ on fish, <i>daphnia</i> or algae	50 (lowest LC ₅₀) or 20 in specific cases (see below)

In the last case referred to above, an uncertainty factor of 20 may be used instead of 50 only if 1-2 L(E)C₅₀ (LC₅₀ in case of fish toxicity, EC₅₀ in case of *daphnia* or algal toxicity) data are available and if it can be concluded from the information for other compounds that the most sensitive species have been tested. Such a rule can be applied only within a group of homologues. It is emphasised that the LTEs (long-term effects) used must be consistent within a group of homologues with respect to the influence of, for example length of alkyl chain for LAS (linear alkylbenzene sulphonate) or number of EO groups (ethoxy groups) for alcohol-ethoxylate if such QSARs can be established.

Any deviation from the above described scheme has to be well-reasoned for the specific chemical.

▼B

Loading factors

Loading factors shall be established according to Commission Directive 93/67/EEC of 20 July 1993 laying down the principles for assessment of risk to man and the environment of substances notified in accordance with Council Directive 67/548/EEC ⁽¹⁾, as last amended by Commission Directive 98/98/EC and to Council Regulation (EEC) No 793/93 ⁽²⁾.

Non-biodegradable organics (anaerobic): flow diagram to define correction factors (CF) ⁽³⁾

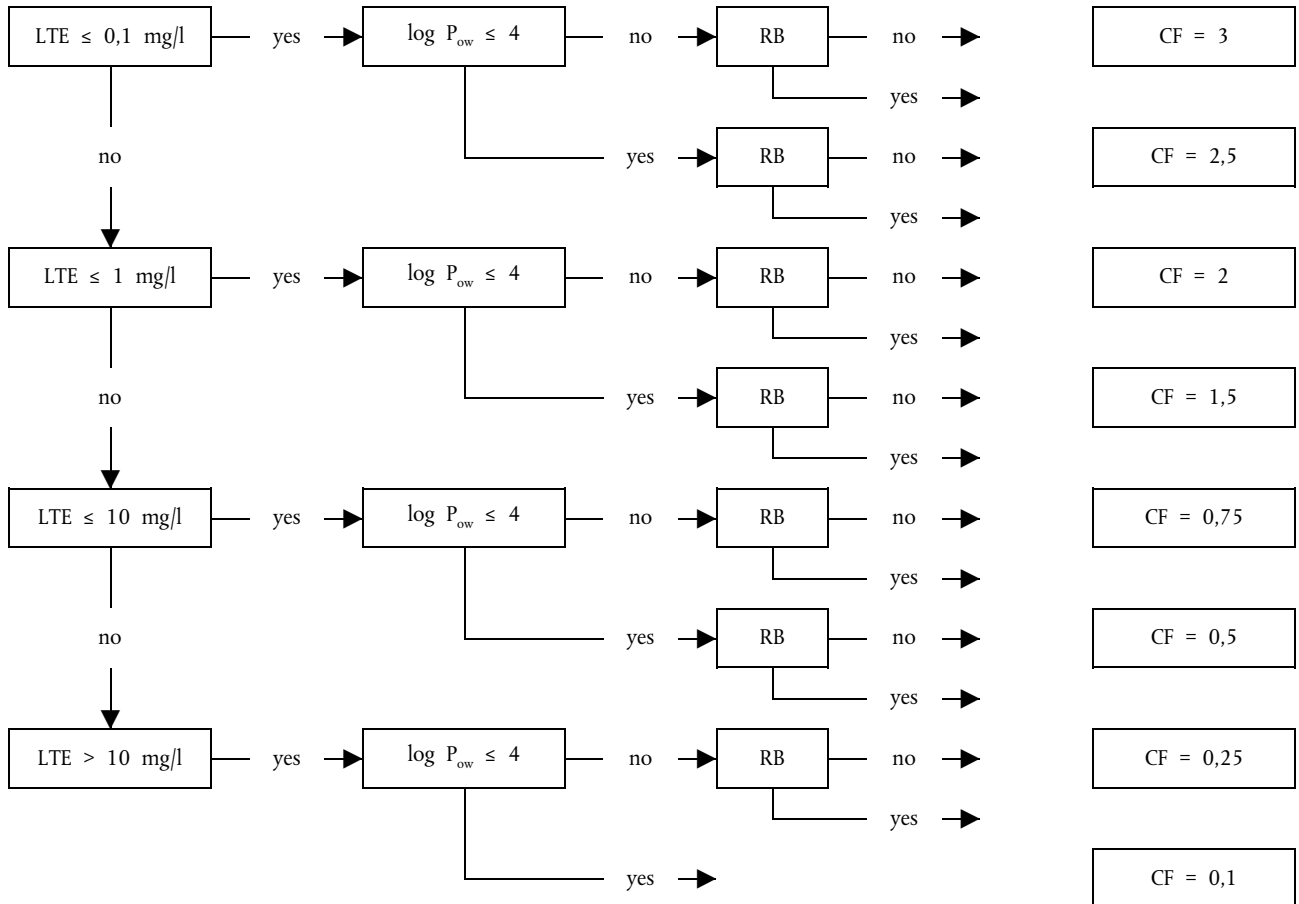

RB: Ready aerobic biodegradability
 LTE: Long-term effect
 CF: Correction factor

⁽¹⁾ OJ L 227, 8.9.1993, p. 9.

⁽²⁾ OJ L 84, 5.4.1993, p. 1.

⁽³⁾ The correction factors shall be established on the basis of the ingredient properties and applied to the dosage expressed in g/wash.

▼B*Appendix II***DEFINITIONS RELATED TO THE ECOLOGICAL CRITERIA****1. Total chemicals**

The Total chemicals criterion is calculated using the dosage minus the water content in g/wash.

2. Critical dilution volume toxicity (CDV_{tox})

The CDV_{tox} is calculated for each ingredient i in the formulation according to the respective data for loading factors (LF) and long-term effects (LTE) in the DID-list in l/wash:

$$\text{CDV}_{\text{tox}} (\text{ingredient } i) = \frac{\text{weight/wash } (i) \times \text{LF } (i)}{\text{LTE } (i)} \times 1\,000$$

The CDV_{tox} of the product is the sum of all ingredients CDV_{tox} in l/wash.

3. Phosphates (as STPP)

Weight per wash of all inorganic phosphates expressed as STPP, in g/wash.

4. Insoluble inorganics

Weight per wash of all ingredients which are insoluble inorganics (see DID-list) in g/wash.

5. Soluble inorganics

Weight per wash of all ingredients which are soluble inorganics (see DID-list) in g/wash.

6. Non-biodegradable organics (aerobic)

Weight per wash of all ingredients which are aerobically non-biodegradable organics (see DID-list) in g/wash.

7. Non-biodegradable organics (anaerobic)

Weight per wash of all ingredients which are non-biodegradable using respective correction factors (see DID-list) in g/wash.

8. Biological oxygene demand (BOD)

The BOD of each ingredients i shall be calculated in g O/wash according to the respective data for THOD in the DID list:

$$\text{BOD} (\text{ingredient } i) = \text{weight} / \text{wash } (i) \times \text{BOD } (i) \text{ in g O/wash}$$

The BOD of the product is the sum of all ingredients BOD in g O /wash. THOD applies only to biodegradable compounds.

9. Heavy duty

Heavy duty detergents put emphasis on the washing performance (soil, stain removal). A detergent shall be considered as heavy duty unless claims made by the manufacturer predominantly promote 'fabric care' (low temperature wash, delicate fibres and colours).

10. Nitro musk

Musk xylene: 5-tert-butyl-2, 4, 6-trinitro-m-xylene

Musk ambrette: 4-tert-butyl-3-methoxy-2, 6-dinitrotoluene

Muskene: 1, 1, 3, 3, 5-pentamethyl-4, 6-dinitroindan

Musk tibetine: 1-tert-butyl-3, 4, 5-trimethyl-2, 6-dinitrobenzene

Musk ketone: 4'-tert-butyl-2', 6'-dimethyl-3', 5'-dinitroacetaphenone

*Appendix III***Data and information required from the applicant by the competent body receiving the application for an Eco-Label****1.1. Declaration of product formulation and calculation of criteria**

The competent body shall require from the manufacturer applying for the eco-label submission of:

- the exact formulation of the product,
- the exact chemical description of ingredients (e.g. identification according to IUPAC, CAS No, sum and structural formulae, purity, type and percentage of impurities, additives; for mixtures, for example surfactants: DID number, composition and spectrum of distribution homologues, isomers, and trade names); analytical evidence of the composition of surfactants,
- the exact tonnage of product which is put on the market (reporting on 1 March, related to the year before),
- the detailed calculation of the criteria,
- a summary test report on the purity of enzymes according to point 4.1 of the Annex to this Decision and a certification on the non-content of production organisms has to be provided,
- a declaration that:
 - the product does not contain the surfactant alkylphenoxylate (APEO), perfumes containing the aromatic nitro compounds referred to in Appendix II, the complex formation agent EDTA and ingredients classified as carcinogenic, mutagenic or teratogenic as defined in Directives 67/548/EEC and 88/379/EEC,
 - phosphonates do not exceed 1 g /wash.

1.2. Washing performance test

The applicant shall submit the results of the EUECO-detergents performance test to the competent body.

1.3. Dosage equipment, packaging and consumer information

In order to prove compliance with the abovementioned requirements, the packages of the product and dosage device shall be required by the competent body from the applicant for the product considered.

In case of differences with respect to different national markets, and different packaging sizes, all these data will be required.

1.4. Application for the eco-label on detergents

The national competent body may audit the applicant company on site and visit the production and packaging facilities.

The competent body itself shall ensure that applications are presented according to the relevant requirements of Regulation (EEC) No 880/92 and the procedural requirements.

▼B*Appendix IV***TABLE OF ABBREVIATIONS**

APEO:	alkyl phenol ethoxylates
BOD:	biological oxygen demand
CDV _{tox} :	critical dilution volume (toxicity)
CF:	correction factor
DID:	detergent ingredients database
DIN:	Deutsches Institut für Normung
EOs:	ethoxy groups
EC ₅₀ :	effect concentration (concentration at which 50 % of the organisms show an effect in defined time)
ECETOC:	European Centre for Ecotoxicology and Toxicology of Chemicals
EDTA:	ethylene diamine tetra acetate
IUPAC:	International Union of Pure and Applied Chemistry
IEC:	International Electrotechnical Commission
ISO:	International Standards Organisation
LC ₅₀ :	lethal concentration (concentration at which 50 % of test organisms show lethal effect in defined time)
LTE:	long-term effect
NOEC:	no observed effect concentration (in a chronic test)
P _{ow} :	partition coefficient octanol/water
QSARs:	quantitative structure activity relationships
RB:	ready biodegradability
STPP:	sodium tripolyphosphate
THOD:	theoretical oxygen demand
UF:	uncertainty factor
WF:	weighting factor