

II

(Non-legislative acts)

ACTS ADOPTED BY BODIES CREATED BY INTERNATIONAL AGREEMENTS

Only the original UN/ECE texts have legal effect under international public law. The status and date of entry into force of this Regulation should be checked in the latest version of the UN/ECE status document TRANS/WP.29/343, available at:
<http://www.unece.org/trans/main/wp29/wp29wgs/wp29gen/wp29fdocstts.html>

Regulation No 10 of the Economic Commission for Europe of the United Nations (UN/ECE) — Uniform provisions concerning the approval of vehicles with regard to electromagnetic compatibility

Revision 3

Incorporating all valid text up to:

03 series of amendments — Date of entry into force: 11 July 2008

CONTENTS

REGULATION

1. Scope
2. Definitions
3. Application for approval
4. Approval
5. Markings
6. Specifications
7. Amendment or extension of a vehicle type approval following electrical/electronic sub-assembly (ESA) addition or substitution
8. Conformity of production
9. Penalties for non-conformity of production
10. Production definitely discontinued
11. Modification and extension of type approval of a vehicle or ESA
12. Transitional provisions
13. Names and addresses of Technical Services conducting approval tests, and of Administrative Departments

ANNEXES

Annex 1 — Examples of approval marks

Annex 2A — Model of information document for type approval of a vehicle, with respect to electromagnetic compatibility

- Annex 2B — Model of information document for type approval of an electric/electronic sub-assembly, with respect to electromagnetic compatibility
- Annex 3A — Model of communication form for vehicle type approval
- Annex 3B — Model of communication form for type approval of electrical/electronic sub-assemblies
- Annex 3C — Attestation with regard to paragraph 3.2.9
- Annex 4 — Method of measurement of radiated broadband electromagnetic emissions from vehicles
- Annex 5 — Method of measurement of radiated narrowband electromagnetic emissions from vehicles
- Annex 6 — Method of testing for immunity of vehicles to electromagnetic radiation
- Annex 7 — Method of measurement of radiated broadband electromagnetic emissions from electrical/electronic sub-assemblies
- Annex 8 — Method of measurement of radiated narrowband electromagnetic emissions from electrical/electronic sub-assemblies
- Annex 9 — Method(s) of testing for immunity of electrical/electronic sub-assemblies to electromagnetic radiation
- Annex 10 — Method(s) of testing for immunity to and emission of transients of electrical/electronic sub-assemblies

1. SCOPE

This Regulation applies to:

- 1.1. vehicles of categories L, M, N and O ⁽¹⁾ with regard to electromagnetic compatibility;
- 1.2. components and separate technical units intended to be fitted in these vehicles with the limitation given in paragraph 3.2.1 with regard to electromagnetic compatibility.

It covers:

- (a) requirements regarding the immunity to radiated and conducted disturbances for functions related to direct control of the vehicle, related to driver, passenger and other road users' protection and related to disturbances, which would cause confusion to the driver or other road users;
- (b) requirements regarding the control of unwanted radiated and conducted emissions to protect the intended use of electrical or electronic equipment at own or adjacent vehicles or nearby, and the control of disturbances from accessories that may be retrofitted to the vehicle.

2. DEFINITIONS

For the purposes of this Regulation:

- 2.1. 'Electromagnetic compatibility' means the ability of a vehicle or component(s) or separate technical unit(s) to function satisfactorily in its electromagnetic environment without introducing intolerable electromagnetic disturbances to anything in that environment.

⁽¹⁾ As defined in Annex 7 to the Consolidated Resolution on the Construction of Vehicles (R.E.3), (document TRANS/WP.29/Rev.1/Amend.2, as last amended by Amend.4).

- 2.2. 'Electromagnetic disturbance' means any electromagnetic phenomenon which may degrade the performance of a vehicle or component(s) or separate technical unit(s), or of any other device, unit of equipment or system operated in vicinity of a vehicle. An electromagnetic disturbance may be electromagnetic noise, an unwanted signal or a change in the propagation medium itself.
- 2.3. 'Electromagnetic immunity' means the ability of a vehicle or component(s) or separate technical unit(s) to operate without degradation of performance in the presence of (specified) electromagnetic disturbances which includes wanted radio frequency signals from radio transmitters or radiated in-band emissions of industrial-scientific-medical (ISM) apparatus, internal or external to the vehicle.
- 2.4. 'Electromagnetic environment' means the totality of electromagnetic phenomena existing at a given location.
- 2.5. 'Broadband emission' means an emission, which has a bandwidth greater than that of a particular measuring apparatus or receiver (International Special Committee on Radio Interference (CISPR) 25, second edition).
- 2.6. 'Narrowband emission' means an emission which has a bandwidth less than that of a particular measuring apparatus or receiver (CISPR 25, second edition).
- 2.7. 'Electrical/electronic system' means (an) electrical and/or electronic device(s) or set(s) of devices together with any associated electrical connections which form part of a vehicle but which are not intended to be type approved separately from the vehicle.
- 2.8. 'Electrical/electronic sub-assembly' (ESA) means an electrical and/or electronic device or set(s) of devices intended to be part of a vehicle, together with any associated electrical connections and wiring, which performs one or more specialised functions. An ESA may be approved at the request of a manufacturer or his authorised representative as either a 'component' or a 'separate technical unit (STU)'.
- 2.9. 'Vehicle type' in relation to electromagnetic compatibility includes all vehicles, which do not differ essentially in such respects as:
- 2.9.1. the overall size and shape of the engine compartment;
- 2.9.2. the general arrangement of the electrical and/or electronic components and the general wiring arrangement;
- 2.9.3. the primary material of which the body or shell of the vehicle is constructed (for example, a steel, aluminium or fibreglass body shell). The presence of panels of different material does not change the vehicle type provided the primary material of the body is unchanged. However, such variations must be notified.
- 2.10. An 'ESA type' in relation to electromagnetic compatibility means ESAs, which do not differ in such essential respects as:
- 2.10.1. the function performed by the ESA;
- 2.10.2. the general arrangement of the electrical and/or electronic components, if applicable.
- 2.11. 'Vehicle wiring harness' means supply voltage, bus system (e.g. CAN), signal or active antenna cables, which are installed by the vehicle manufacturer.

- 2.12. 'Immunity related functions' are:
- (a) Functions related to the direct control of the vehicle:
 - (i) by degradation or change in: e.g. engine, gear, brake, suspension, active steering, speed limitation devices;
 - (ii) by affecting driver's position: e.g. seat or steering wheel positioning;
 - (iii) by affecting driver's visibility: e.g. dipped beam, windscreen wiper.
 - (b) Functions related to driver, passenger and other road user protection:
 - (i) e.g. airbag and safety restraint systems.
 - (c) Functions which when disturbed cause confusion to the driver or other road users:
 - (i) optical disturbances: incorrect operation of e.g. direction indicators, stop lamps, end outline marker lamps, rear position lamp, light bars for emergency system, wrong information from warning indicators, lamps or displays related to functions in subparagraphs (a) or (b) which might be observed in the direct view of the driver;
 - (ii) acoustical disturbances: incorrect operation of e.g. anti-theft alarm, horn.
 - (d) Functions related to vehicle data bus functionality:
 - (i) by blocking data transmission on vehicle data bus-systems, which are used to transmit data, required to ensure the correct functioning of other immunity related functions.
 - (e) Functions which when disturbed affect vehicle statutory data: e.g. tachograph, odometer.
3. APPLICATION FOR APPROVAL
- 3.1. Approval of a vehicle type
- 3.1.1. The application for approval of a vehicle type, with regard to its electromagnetic compatibility, shall be submitted by the vehicle manufacturer.
- 3.1.2. A model of information document is shown in Annex 2A.
- 3.1.3. The vehicle manufacturer shall draw up a schedule describing all relevant vehicle electrical/electronic systems or ESAs, body styles, variations in body material, general wiring arrangements, engine variations, left-hand/right-hand drive versions and wheelbase versions. Relevant vehicle electrical/electronic systems or ESAs are those which may emit significant broadband or narrowband radiation and/or those which are involved in immunity related functions of the vehicle (see paragraph 2.12).
- 3.1.4. A vehicle representative of the type to be approved shall be selected from this schedule by mutual agreement between the manufacturer and the Competent Authority. The choice of vehicle shall be based on the electrical/electronic systems offered by the manufacturer. One or more vehicles may be selected from this schedule if it is considered by mutual agreement between the manufacturer and the Competent Authority that different electrical/electronic systems are included which are likely to have a significant effect on the vehicle's electromagnetic compatibility compared with the first representative vehicle.

- 3.1.5. The choice of the vehicle(s) in conformity with paragraph 3.1.4 above shall be limited to vehicle/electrical/electronic system combinations intended for actual production.
- 3.1.6. The manufacturer may supplement the application with a report on tests which have been carried out. Any such data provided may be used by the approval authority for the purpose of drawing up the communication form for type-approval.
- 3.1.7. If the Technical Service responsible for the type approval test carries out the test itself, then a vehicle representative of the type to be approved according to paragraph 3.1.4 shall be provided.
- 3.1.8. For vehicles of categories M, N, and O the vehicle manufacturer must provide a statement of frequency bands, power levels, antenna positions and installation provisions for the installation of radio frequency transmitters (RF-transmitters), even if the vehicle is not equipped with an RF transmitter at time of type approval. This should cover all mobile radio services normally used in vehicles. This information must be made publicly available following the type approval.

Vehicle manufacturers must provide evidence that vehicle performance is not adversely affected by such transmitter installations.

3.2. ESA type approval

3.2.1. Applicability of this Regulation to ESA:

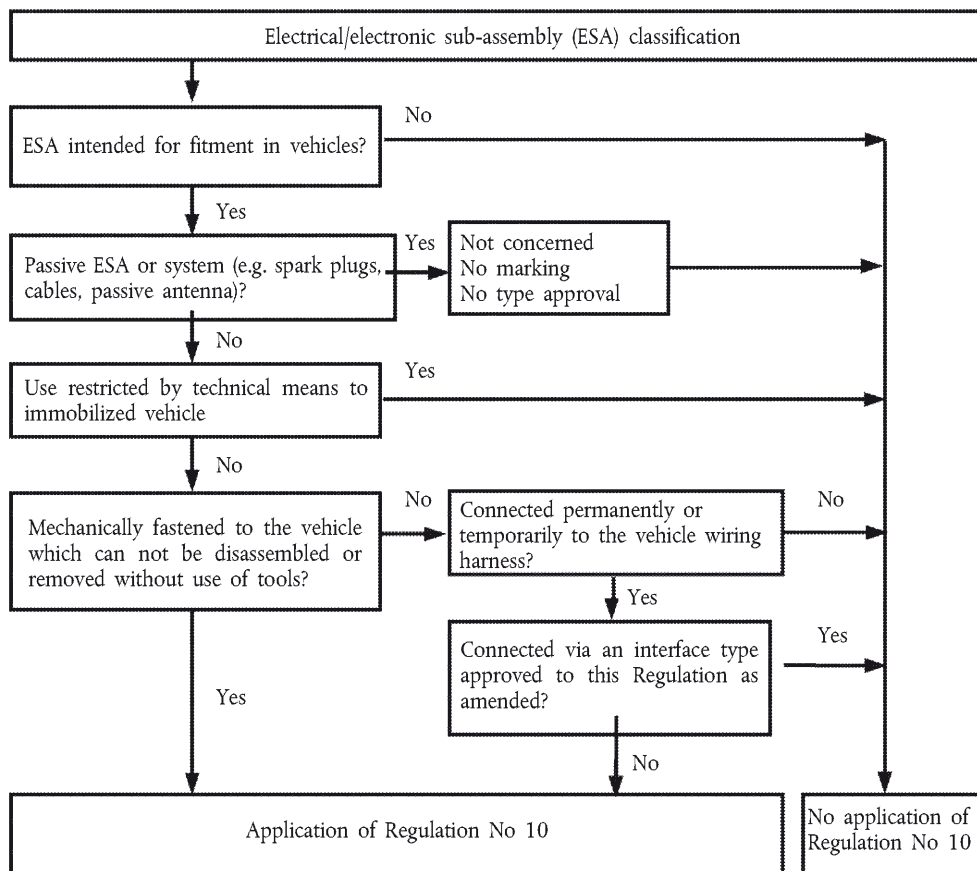

- 3.2.2. The application for approval of a type of ESA with regard to its electromagnetic compatibility shall be submitted by the vehicle manufacturer or by the manufacturer of the ESA.

- 3.2.3. A model of information document is shown in Annex 2B.
- 3.2.4. The manufacturer may supplement the application with a report on tests which have been carried out. Any such data provided may be used by the approval authority for the purpose of drawing up the communication form for type-approval.
- 3.2.5. If the Technical Service responsible for the type approval test carries out the test itself, then a sample of the ESA system representative of the type to be approved shall be provided, if necessary, after discussion with the manufacturer on, e.g., possible variations in the layout, number of components, number of sensors. If the Technical Service deems it necessary, it may select a further sample.
- 3.2.6. The sample(s) must be clearly and indelibly marked with the manufacturer's trade name or mark and the type designation.
- 3.2.7. Where applicable, any restrictions on use should be identified. Any such restrictions should be included in Annexes 2B and/or 3B.
- 3.2.8. ESA which are brought to the market as spare parts need no type approval if they are obviously marked as a spare part by an identification number and if they are identical and from the same manufacturer as the corresponding original equipment manufacturer (OEM) part for an already type approved vehicle.
- 3.2.9. Components sold as aftermarket equipment and intended for the installation in motor vehicles need no type approval if they are not related to immunity related functions (see paragraph 2.12). In this case a declaration must be issued by the manufacturer that the ESA fulfils the requirements of this Regulation and in particular the limits defined in paragraphs 6.5, 6.6, 6.8 and 6.9.

During the transition period, ending on 4 November 2008, the person or legal entity responsible for placing on the market of such a product has to submit all relevant information and/or a sample to a Technical Service which will determine if the equipment is immunity related or not. The result of the inspection shall be available within three weeks and not require additional testing. A document according to the example given in Annex 3C shall be issued by the Technical Service within the same period. In case of doubts and if the Technical Service refuses to issue an attestation according to Annex 3C, the manufacturer has to apply for type approval for his product.

4. APPROVAL

4.1. Type approval procedures

4.1.1. Type approval of a vehicle

The following alternative procedures for vehicle type approval may be used at the discretion of the vehicle manufacturer.

4.1.1.1. Approval of a vehicle installation

A vehicle installation may be type approved directly by following the provisions laid down in paragraph 6 of this Regulation. If this procedure is chosen by a vehicle manufacturer, no separate testing of electrical/electronic systems or ESAs is required.

4.1.1.2. Approval of vehicle type by testing of individual ESAs

A vehicle manufacturer may obtain approval for the vehicle by demonstrating to the approval authority that all the relevant (see paragraph 3.1.3 of this Regulation) electrical/electronic systems or ESAs have been approved in accordance with this Regulation and have been installed in accordance with any conditions attached thereto.

- 4.1.1.3. A manufacturer may obtain approval according to this Regulation if the vehicle has no equipment of the type, which is subject to immunity or emission tests. Such approvals do not require testing.
- 4.1.2. Type approval of an ESA
- Type approval may be granted to an ESA to be fitted either to any vehicle type (component approval) or to a specific vehicle type or types requested by the ESA manufacturer (separate technical unit approval).
- 4.1.3. ESAs, which are intentional RF transmitters, which have not received type approval in conjunction with a vehicle manufacturer, must be supplied with suitable installation guidelines.
- 4.2. Granting of type approval
- 4.2.1. Vehicle
- 4.2.1.1. If the representative vehicle fulfils the requirements of paragraph 6 of this Regulation, type approval shall be granted.
- 4.2.1.2. A model of communication form for type approval is contained in Annex 3A.
- 4.2.2. ESA
- 4.2.2.1. If the representative ESA system(s) fulfil(s) the requirements of paragraph 6 of this Regulation, type approval shall be granted.
- 4.2.2.2. A model of communication form for type approval is contained in Annex 3B.
- 4.2.3. In order to draw up the communication forms referred to in paragraph 4.2.1.2 or 4.2.2.2 above, the Competent Authority of the Contracting Party granting the approval may use a report prepared or approved by a recognised laboratory or in accordance with the provisions of this Regulation.
- 4.3. Approval, or refusal of approval, of a type of vehicle or ESA in accordance with this Regulation shall be notified to the Parties to the Agreement applying this Regulation on a form conforming to the model in Annex 3A or 3B to this Regulation, accompanied by photographs and/or diagrams or drawings on an appropriate scale supplied by the applicant in a format not larger than A4 (210 × 297 mm) or folded to those dimensions.
5. MARKINGS
- 5.1. An approval number shall be assigned to each vehicle or ESA type approved. The first two digits of this number (at present 03) shall indicate the series of amendments corresponding to the most recent essential technical amendments made to the Regulation at the date of approval. A Contracting Party may not assign the same approval number to another type of vehicle or ESA.
- 5.2. Presence of markings
- 5.2.1. Vehicle
- An approval mark described in paragraph 5.3 below shall be affixed to every vehicle conforming to a type approved under this Regulation.
- 5.2.2. Sub-assembly
- An approval mark described in paragraph 5.3 below shall be affixed to every ESA conforming to a type approved under this Regulation.
- No marking is required for electrical/electronic systems built into vehicles which are approved as units.

- 5.3. An international approval mark must be affixed, in a conspicuous and easily accessible place specified on the approval communication form, on each vehicle conforming to the type approved under this Regulation. This mark shall comprise:
- 5.3.1. A circle containing the letter 'E', followed by the distinguishing number of the country granting the approval⁽¹⁾.
- 5.3.2. The number of this Regulation, followed by the letter 'R', a dash and the approval number to the right of the circle specified in paragraph 5.3.1.
- 5.4. An example of the type-approval mark is shown in Annex 1 to this Regulation.
- 5.5. Markings on ESAs in conformity with paragraph 5.3 above need not be visible when the ESA is installed in the vehicle.
6. SPECIFICATIONS
- 6.1. General specifications
- 6.1.1. A vehicle and its electrical/electronic system(s) or ESA(s) shall be so designed, constructed and fitted as to enable the vehicle, in normal conditions of use, to comply with the requirements of this Regulation.
- 6.1.1.1. A vehicle shall be tested for radiated emissions and for immunity to radiated disturbances. No tests for conducted emissions or immunity to conducted disturbances are required for vehicle type approval.
- 6.1.1.2. ESA(s) shall be tested for radiated and conducted emissions, for immunity to radiated and conducted disturbances.
- 6.1.2. Before testing the Technical Service has to prepare a test plan in conjunction with the manufacturer, which contains at least mode of operation, stimulated function(s), monitored function(s), pass/fail criterion(criteria) and intended emissions.
- 6.2. Specifications concerning broadband electromagnetic radiation from vehicles
- 6.2.1. Method of measurement

The electromagnetic radiation generated by the vehicle representative of its type shall be measured using the method described in Annex 4. The method of measurement shall be defined by the vehicle manufacturer in accordance with the Technical Service.

⁽¹⁾ 1 for Germany, 2 for France, 3 for Italy, 4 for the Netherlands, 5 for Sweden, 6 for Belgium, 7 for Hungary, 8 for the Czech Republic, 9 for Spain, 10 for Serbia, 11 for the United Kingdom, 12 for Austria, 13 for Luxembourg, 14 for Switzerland, 15 (vacant), 16 for Norway, 17 for Finland, 18 for Denmark, 19 for Romania, 20 for Poland, 21 for Portugal, 22 for the Russian Federation, 23 for Greece, 24 for Ireland, 25 for Croatia, 26 for Slovenia, 27 for Slovakia, 28 for Belarus, 29 for Estonia, 30 (vacant), 31 for Bosnia and Herzegovina, 32 for Latvia, 33 (vacant), 34 for Bulgaria, 35 (vacant), 36 for Lithuania, 37 for Turkey, 38 (vacant), 39 for Azerbaijan, 40 for The former Yugoslav Republic of Macedonia, 41 (vacant), 42 for the European Community (Approvals are granted by its Member States using their respective ECE symbol), 43 for Japan, 44 (vacant), 45 for Australia, 46 for Ukraine, 47 for South Africa, 48 for New Zealand, 49 for Cyprus, 50 for Malta, 51 for the Republic of Korea, 52 for Malaysia, 53 for Thailand, 54 and 55 (vacant), 56 for Montenegro, 57 (vacant) and 58 for Tunisia. Subsequent numbers shall be assigned to other countries in the chronological order in which they ratify or accede to the Agreement Concerning the Adoption of Uniform Technical Prescriptions for Wheeled Vehicles, Equipment and Parts which can be Fitted and/or be Used on Wheeled Vehicles and the Conditions for Reciprocal Recognition of Approvals Granted on the Basis of these Prescriptions, and the numbers thus assigned shall be communicated by the Secretary-General of the United Nations to the Contracting Parties to the Agreement.

6.2.2. Vehicle broadband type approval limits

- 6.2.2.1. If measurements are made using the method described in Annex 4 using a vehicle-to-antenna spacing of $10,0 \pm 0,2$ m, the limits shall be 32 dB microvolts/m in the 30 to 75 MHz frequency band and 32 to 43 dB microvolts/m in the 75 to 400 MHz frequency band, this limit increasing logarithmically with frequencies above 75 MHz as shown in Appendix 2. In the 400 to 1 000 MHz frequency band the limit remains constant at 43 dB microvolts/m.
- 6.2.2.2. If measurements are made using the method described in Annex 4 using a vehicle-to-antenna spacing of $3,0 \pm 0,05$ m, the limits shall be 42 dB microvolts/m in the 30 to 75 MHz frequency band and 42 to 53 dB microvolts/m in the 75 to 400 MHz frequency band, this limit increasing logarithmically with frequencies above 75 MHz as shown in Appendix 3. In the 400 to 1 000 MHz frequency band the limit remains constant at 53 dB microvolts/m.
- 6.2.2.3. On the vehicle representative of its type, the measured values, expressed in dB microvolts/m shall be below the type approval limits.

6.3. Specifications concerning narrowband electromagnetic radiation from vehicles

6.3.1. Method of measurement

The electromagnetic radiation generated by the vehicle representative of its type shall be measured using the method described in Annex 5. These shall be defined by the vehicle manufacturer in accordance with the Technical Service.

6.3.2. Vehicle narrowband type approval limits

- 6.3.2.1. If measurements are made using the method described in Annex 5 using a vehicle-to-antenna spacing of $10,0 \pm 0,2$ m, the limits shall be 22 dB microvolts/m in the 30 to 75 MHz frequency band and 22 to 33 dB microvolts/m in the 75 to 400 MHz frequency band, this limit increasing logarithmically with frequencies above 75 MHz as shown in Appendix 4. In the 400 to 1 000 MHz frequency band the limit remains constant at 33 dB microvolts/m.
- 6.3.2.2. If measurements are made using the method described in Annex 5 using a vehicle-to-antenna spacing of $3,0 \pm 0,05$ m, the limit shall be 32 dB microvolts/m in the 30 to 75 MHz frequency band and 32 to 43 dB microvolts/m in the 75 to 400 MHz frequency band, this limit increasing logarithmically with frequencies above 75 MHz as shown in Appendix 5. In the 400 to 1 000 MHz frequency band the limit remains constant at 43 dB microvolts/m.
- 6.3.2.3. On the vehicle representative of its type, the measured values, expressed in dB microvolts/m, shall be below the type approval limit.
- 6.3.2.4. Notwithstanding the limits defined in paragraphs 6.3.2.1, 6.3.2.2 and 6.3.2.3 of this Annex, if, during the initial step described in paragraph 1.3 of Annex 5, the signal strength measured at the vehicle broadcast radio antenna is less than 20 dB microvolts over the frequency range 76 to 108 MHz measured with an average detector, then the vehicle shall be deemed to comply with the limits for narrowband emissions and no further testing will be required.

6.4. Specifications concerning immunity of vehicles to electromagnetic radiation

6.4.1. Method of testing

The immunity to electromagnetic radiation of the vehicle representative of its type shall be tested by the method described in Annex 6.

6.4.2. Vehicle immunity type approval limits

- 6.4.2.1. If tests are made using the method described in Annex 6, the field strength shall be 30 volts/m rms (root mean squared) in over 90 per cent of the 20 to 2 000 MHz frequency band and a minimum of 25 volts/m rms over the whole 20 to 2 000 MHz frequency band.

- 6.4.2.2. The vehicle representative of its type shall be considered as complying with immunity requirements if, during the tests performed in accordance with Annex 6, there shall be no degradation of performance of 'immunity related functions'.
- 6.5. Specification concerning broadband electromagnetic interference generated by ESAs.
- 6.5.1. Method of measurement
- The electromagnetic radiation generated by the ESA representative of its type shall be measured by the method described in Annex 7.
- 6.5.2. ESA broadband type approval limits
- 6.5.2.1. If measurements are made using the method described in Annex 7, the limits shall be 62 to 52 dB microvolts/m in the 30 to 75 MHz frequency band, this limit decreasing logarithmically with frequencies above 30 MHz, and 52 to 63 dB microvolts/m in the 75 to 400 MHz band, this limit increasing logarithmically with frequencies above 75 MHz as shown in Appendix 6. In the 400 to 1 000 MHz frequency band the limit remains constant at 63 dB microvolts/m.
- 6.5.2.2. On the ESA representative of its type, the measured values, expressed in dB microvolts/m, shall be below the type approval limits.
- 6.6. Specifications concerning narrowband electromagnetic interference generated by ESAs.
- 6.6.1. Method of measurement
- The electromagnetic radiation generated by the ESA representative of its type shall be measured by the method described in Annex 8.
- 6.6.2. ESA narrowband type approval limits
- 6.6.2.1. If measurements are made using the method described in Annex 8, the limits shall be 52 to 42 dB microvolts/m in the 30 to 75 MHz frequency band, this limit decreasing logarithmically with frequencies above 30 MHz, and 42 to 53 dB microvolts/m in the 75 to 400 MHz band, this limit increasing logarithmically with frequencies above 75 MHz as shown in Appendix 7. In the 400 to 1 000 MHz frequency band the limit remains constant at 53 dB microvolts/m.
- 6.6.2.2. On the ESA representative of its type, the measured value, expressed in dB microvolts/m shall be below the type approval limits.
- 6.7. Specifications concerning immunity of ESAs to electromagnetic radiation
- 6.7.1. Method(s) of testing
- The immunity to electromagnetic radiation of the ESA representative of its type shall be tested by the method(s) chosen from those described in Annex 9.
- 6.7.2. ESA immunity type approval limits
- 6.7.2.1. If tests are made using the methods described in Annex 9, the immunity test levels shall be 60 volts/m for the 150 mm stripline testing method, 15 volts/m for the 800 mm stripline testing method, 75 volts/m for the Transverse Electromagnetic Mode (TEM) cell testing method, 60 mA for the bulk current injection (BCI) testing method and 30 volts/m for the free field testing method in over 90 per cent of the 20 to 2 000 MHz frequency band, and to a minimum of 50 volts/m for the 150 mm stripline testing method, 12,5 volts/m for the 800 mm stripline testing method, 62,5 volts/m, for the TEM cell testing method, 50 mA for the bulk current injection (BCI) testing method and 25 volts/m for the free field testing method over the whole 20 to 2 000 MHz frequency band.

6.7.2.2. The ESA representative of its type shall be considered as complying with immunity requirements if, during the tests performed in accordance with Annex 9, there shall be no degradation of performance of 'immunity related functions'.

6.8. Specifications concerning the immunity to transient disturbances conducted along supply lines.

6.8.1. Method of testing

The immunity of ESA representative of its type shall be tested by the method(s) according to ISO 7637-2, second edition 2004 as described in Annex 10 with the test levels given in table 1.

Table 1
Immunity of ESA

Test pulse number	Immunity test level	Functional status for systems	
		Related to immunity related functions	Not related to immunity related functions
1	III	C	D
2a	III	B	D
2b	III	C	D
3a/3b	III	A	D
4	III	B (for ESA which must be operational during engine start phases) C (for other ESA)	D

6.9. Specifications concerning the emission of conducted disturbances

6.9.1. Method of testing

The emission of ESA representative of its type shall be tested by the method(s) according to ISO 7637-2, second edition 2004 as described in Annex 10 for the levels given in table 2.

Table 2
Maximum allowed pulse amplitude

Polarity of pulse amplitude	Maximum allowed pulse amplitude for	
	Vehicles with 12 V systems	Vehicles with 24 V systems
Positive	+ 75	+ 150
Negative	- 100	- 450

6.10. Exceptions

6.10.1. Where a vehicle or electrical/electronic system or ESA does not include an electronic oscillator with an operating frequency greater than 9 kHz, it shall be deemed to comply with paragraph 6.3.2 or 6.6.2 and with Annexes 5 and 8.

6.10.2. Vehicles which do not have electrical/electronic systems with 'immunity related functions' need not be tested for immunity to radiated disturbances and shall be deemed to comply with paragraph 6.4 and with Annex 6 to this Regulation.

- 6.10.3. ESAs with no immunity related functions need not be tested for immunity to radiated disturbances and shall be deemed to comply with paragraph 6.7 and with Annex 9 to this Regulation.
- 6.10.4. Electrostatic discharge
- For vehicles fitted with tyres, the vehicle body/chassis can be considered to be an electrically isolated structure. Significant electrostatic forces in relation to the vehicle's external environment only occur at the moment of occupant entry into or exit from the vehicle. As the vehicle is stationary at these moments, no type approval test for electrostatic discharge is deemed necessary.
- 6.10.5. Conducted emission
- ESAs that are not switched, contain no switches or do not include inductive loads need not be tested for conducted emission and shall be deemed to comply with paragraph 6.9.
- 6.10.6. The loss of function of receivers during the immunity test, when the test signal is within the receiver bandwidth (RF exclusion band) as specified for the specific radio service/product in the harmonised international EMC standard, does not necessarily lead to a fail criterion.
- 6.10.7. RF transmitters shall be tested in the transmit mode. Wanted emissions (e.g. from RF transmitting systems) within the necessary bandwidth and out of band emissions are disregarded for the purpose of this Regulation. Spurious emissions are subject to this Regulation.
- 6.10.7.1. 'Necessary Bandwidth': for a given class of emission, the width of the frequency band which is just sufficient to ensure the transmission of information at the rate and with the quality required under specified conditions (Article 1, No 1.152 of the International Telecommunication Union (ITU) Radio Regulations).
- 6.10.7.2. 'Out-of-band Emissions': Emission on a frequency or frequencies immediately outside the necessary bandwidth which results from the modulation process, but excluding spurious emissions (Article 1, No 1.144 of the ITU Radio Regulations).
- 6.10.7.3. 'Spurious Emission': In every modulation process additional undesired signals exist. They are summarised under the expression 'spurious emissions'. Spurious emissions are emissions on a frequency or frequencies, which are outside the necessary bandwidth and the level of which may be reduced without affecting the corresponding transmission of information. Spurious emissions include harmonic emissions, parasitic emissions, intermodulation products and frequency conversion products, but exclude out-of-band emissions (Article 1 No 1.145 of the ITU Radio Regulations).
7. AMENDMENT OR EXTENSION OF A VEHICLE TYPE APPROVAL FOLLOWING ESA ADDITION OR SUBSTITUTION
- 7.1. Where a vehicle manufacturer has obtained type approval for a vehicle installation and wishes to fit an additional or substitutional electrical/electronic system or ESA which has already received approval under this Regulation, and which will be installed in accordance with any conditions attached thereto, the vehicle approval may be extended without further testing. The additional or substitutional electrical/electronic system or ESA shall be considered as part of the vehicle for conformity of production purposes.
- 7.2. Where the additional or substitutional part(s) has (have) not received approval pursuant to this Regulation, and if testing is considered necessary, the whole vehicle shall be deemed to conform if the new or revised part(s) can be shown to conform to the relevant requirements of paragraph 6 or if, in a comparative test, the new part can be shown not to be likely to adversely affect the conformity of the vehicle type.

- 7.3. The addition by a vehicle manufacturer to an approved vehicle of standard domestic or business equipment, other than mobile communication equipment, which conforms to other regulations, and the installation, substitution or removal of which is according to the recommendations of the equipment and vehicle manufacturers, shall not invalidate the vehicle approval. This shall not preclude vehicle manufacturers fitting communication equipment in accordance with suitable installation guidelines developed by the vehicle manufacturer and/or manufacturer(s) of such communication equipment. The vehicle manufacturer shall provide evidence (if requested by the test authority) that vehicle performance is not adversely affected by such transmitters. This can be a statement that the power levels and installation are such that the immunity levels of this Regulation offer sufficient protection when subject to transmission alone i.e. excluding transmission in conjunction with the tests specified in paragraph 6. This Regulation does not authorise the use of a communication transmitter when other requirements on such equipment or its use apply.

8. CONFORMITY OF PRODUCTION

The conformity of production procedures shall comply with those set out in the Agreement, Appendix 2 (E/ECE/324-E/ECE/TRANS/505/Rev.2), with the following requirements:

- 8.1. Vehicles or components or ESAs approved under this Regulation shall be so manufactured as to conform to the type approved by meeting the requirements set forth in paragraph 6 above.
- 8.2. Conformity of production of the vehicle or component or separate technical unit shall be checked on the basis of the data contained in the communication form(s) for type approval set out in Annex 3A and/or 3B to this Regulation.
- 8.3. If the Competent Authority is not satisfied with the checking procedure of the manufacturer, then paragraphs 8.3.1 and 8.3.2 below shall apply.
- 8.3.1. When the conformity of a vehicle, component or ESA taken from the series is being verified, production shall be deemed to conform to the requirements of this Regulation in relation to broadband electromagnetic disturbances and narrowband electromagnetic disturbances if the levels measured do not exceed by more than 2 dB (25 per cent) the reference limits prescribed in paragraphs 6.2.2.1, 6.2.2.2, 6.3.2.1 and 6.3.2.2 (as appropriate).
- 8.3.2. When the conformity of a vehicle, component or ESA taken from the series is being verified, production shall be deemed to conform to the requirements of this Regulation in relation to immunity to electromagnetic radiation if the vehicle ESA does not exhibit any degradation relating to the direct control of the vehicle which could be observed by the driver or other road user when the vehicle is in the state defined in Annex 6, paragraph 4, and is subjected to a field strength, expressed in Volts/m, up to 80 per cent of the reference limits prescribed in paragraph 6.4.2.1 above.
- 8.3.3. If the conformity of a component, or Separate Technical Unit (STU) taken from the series is being verified, production shall be deemed to conform to the requirements of this Regulation in relation to immunity to conducted disturbances and emission if the component or STU shows no degradation of performance of 'immunity related functions' up to levels given in paragraph 6.8.1 and does not exceed the levels given in paragraph 6.9.1.

9. PENALTIES FOR NON-CONFORMITY OF PRODUCTION

- 9.1. The approval granted in respect of a type of vehicle, component or separate technical unit pursuant to this Regulation may be withdrawn if the requirements laid down in paragraph 6 above are not complied with or if the selected vehicles fail to pass the tests provided for in paragraph 6 above.

- 9.2. If a Party to the Agreement which applies this Regulation withdraws an approval it has previously granted, it shall forthwith notify the other Contracting Parties applying this Regulation thereof by means of a communication form conforming to the model in Annexes 3A and 3B to this Regulation.
10. PRODUCTION DEFINITELY DISCONTINUED
- If the holder of an approval permanently ceases to manufacture a type of vehicle or ESA approved in accordance with this Regulation, he shall so inform the authority which granted the approval, which shall in turn notify the other Parties to the 1958 Agreement which apply this Regulation, by means of a communication form conforming to the model in Annexes 3A and 3B to this Regulation.
11. MODIFICATION AND EXTENSION OF TYPE APPROVAL OF A VEHICLE OR ESA
- 11.1. Every modification of the vehicle or ESA type shall be notified to the Administrative Department which granted approval of the vehicle type. This department may then either:
- 11.1.1. consider that the modifications made are unlikely to have an appreciable adverse effect and that in any case the vehicle or ESA still meets the requirements; or
- 11.1.2. require a further test report from the Technical Service responsible for conducting the tests.
- 11.2. Notice of conformation of approval or of refusal of approval, accompanied by particulars of the modifications, shall be communicated by the procedure indicated in paragraph 4 above to the Parties to the Agreement applying this Regulation.
- 11.3. The Competent Authority granting the approval extension shall assign a serial number to the extension and so notify the other Parties to the 1958 Agreement applying this Regulation by means of a communication form conforming to the models in Annexes 3A and 3B to this Regulation.
12. TRANSITIONAL PROVISIONS
- 12.1. As from the official date of entry into force of the 03 series of amendments, no Contracting Party applying this Regulation shall refuse to grant ECE approval under this Regulation as amended by the 03 series of amendments.
- 12.2. As from 12 months after the date of entry into force of this Regulation, as amended by the 03 series of amendments, Contracting Parties applying this Regulation shall grant approvals only if the vehicle type, component or separate technical unit to be approved meets the requirements of this Regulation as amended by the 03 series of amendments.
- 12.3. Contracting Parties applying this Regulation shall not refuse to grant extensions of approval to the preceding series of amendments to this Regulation.
- 12.4. Starting 48 months after the entry into force of the 03 series of amendments to this Regulation, Contracting Parties applying this Regulation may refuse first national registration (first entry into service) of a vehicle, component or separate technical unit which does not meet the requirements of the 03 series of amendments to this Regulation.

13. NAMES AND ADDRESSES OF TECHNICAL SERVICES CONDUCTING APPROVAL TESTS AND ADMINISTRATIVE DEPARTMENTS

The Parties to the 1958 Agreement applying this Regulation shall communicate to the United Nations Secretariat the names and addresses of the Technical Services conducting approval tests and of the Administrative Departments which grant approvals and to which forms certifying approval or extension, refusal or withdrawal of approval, issued in other countries, are to be sent.

*Appendix 1***List of standards referred to in this Regulation**

1. CISPR 12 'Vehicles', motorboats' and spark-ignited engine-driven devices' radio disturbance characteristics — Limits and methods of measurement', fifth edition 2001.
 2. CISPR 16-1-4 'Specifications for radio disturbance and immunity measuring apparatus and methods — Part 1: Radio disturbance and immunity measuring apparatus', Edition 1.1. 2004.
 3. CISPR 25 'Limits and methods of measurement of radio disturbance characteristics for the protection of receivers used on board vehicles', second edition 2002.
 4. ISO 7637-1 'Road vehicles — Electrical disturbance from conduction and coupling — Part 1: Definitions and general considerations', second edition 2002.
 5. ISO 7637-2 'Road vehicles — Electrical disturbance from conduction and coupling — Part 2: Electrical transient conduction along supply lines only on vehicles with nominal 12 V or 24 V supply voltage', second edition 2004.
 6. ISO-EN 17025 'General requirements for the competence of testing and calibration laboratories', first edition 1999.
 7. ISO 11451 'Road vehicles — Electrical disturbances by narrowband radiated electromagnetic energy — Vehicle test methods':

Part 1: General and definitions (ISO 11451-1, third edition 2005);

Part 2: Off-vehicle radiation source (ISO 11451-2, third edition 2005);

Part 4: Bulk current injection (BCI) (ISO 11451-4, first edition 1995).
 8. ISO 11452 'Road vehicles — Electrical disturbances by narrowband radiated electromagnetic energy — Component test methods':

Part 1: General and definitions (ISO 11452-1, third edition 2005);

Part 2: Absorber-lined chamber (ISO 11452-2, second edition 2004);

Part 3: Transverse electromagnetic mode (TEM) cell (ISO 11452-3, third edition 2001);

Part 4: Bulk current injection (BCI) (ISO 11452-4, third edition 2005);

Part 5: Stripline (ISO 11452-5, second edition 2002).
 9. ITU Radio Regulations, edition 2001.
-

Appendix 2

Vehicle broadband reference limits

Antenna-vehicle separation: 10 m

Limit E (dB μ V/m) at frequency F (MHz)		
30-75 MHz	75-400 MHz	400-1 000 MHz
E = 32	E = 32 + 15,13 log (F/75)	E = 43

Vehicle radiated emission limit
Broadband type approval limit - 10 m
Quasi-peak detector - 120 kHz bandwidth

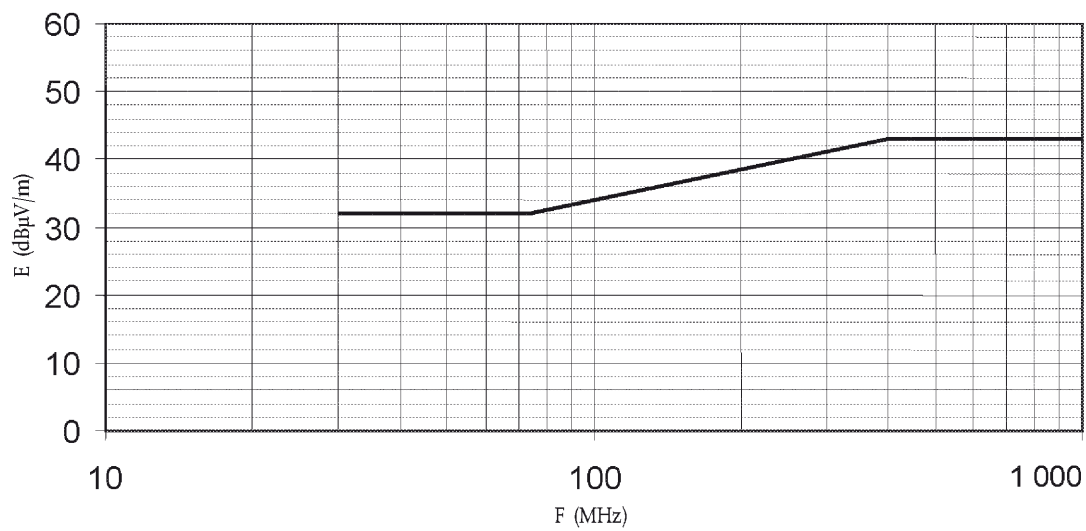

Frequency — megahertz — logarithmic

(See paragraph 6.2.2.1 of this Regulation)

Appendix 3

Vehicle broadband reference limits

Antenna-vehicle separation: 3 m

Limit E (dB μ V/m) at frequency F (MHz)		
30-75 MHz	75-400 MHz	400-1 000 MHz
E = 42	$E = 42 + 15,13 \log (F/75)$	E = 53

Vehicle radiated emission limit
Broadband type approval limit - 3 m
Quasi-peak detector - 120 kHz bandwidth

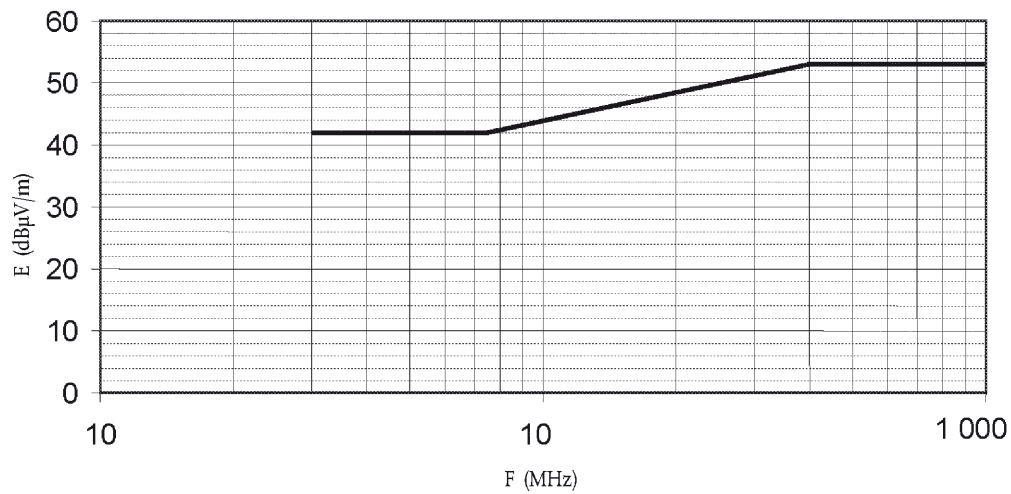

Frequency — megahertz — logarithmic
 (See paragraph 6.2.2.2 of this Regulation)

Appendix 4

Vehicle narrowband reference limits

Antenna-vehicle separation: 10 m

Limit E (dB μ V/m) at frequency F (MHz)		
30-75 MHz	75-400 MHz	400-1 000 MHz
E = 22	E = 22 + 15,13 log (F/75)	E = 33

Vehicle radiated emission limit
Narrowband type approval limit - 10 m
Average detector - 120 kHz bandwidth

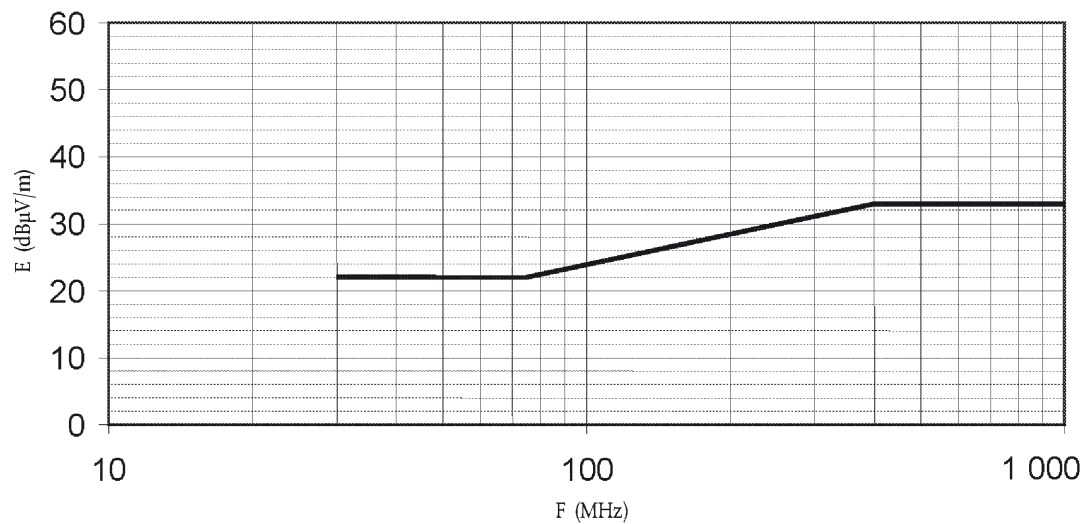

Frequency — megahertz — logarithmic
 (See paragraph 6.3.2.1 of this Regulation)

Appendix 5

Vehicle narrowband reference limits

Antenna-vehicle separation: 3 m

Limit E (dB μ V/m) at frequency F (MHz)		
30-75 MHz	75-400 MHz	400-1 000 MHz
E = 32	$E = 32 + 15,13 \log (F/75)$	E = 43

Vehicle radiated emission limit
Narrowband type approval limit - 3 m
Average detector - 120 kHz bandwidth

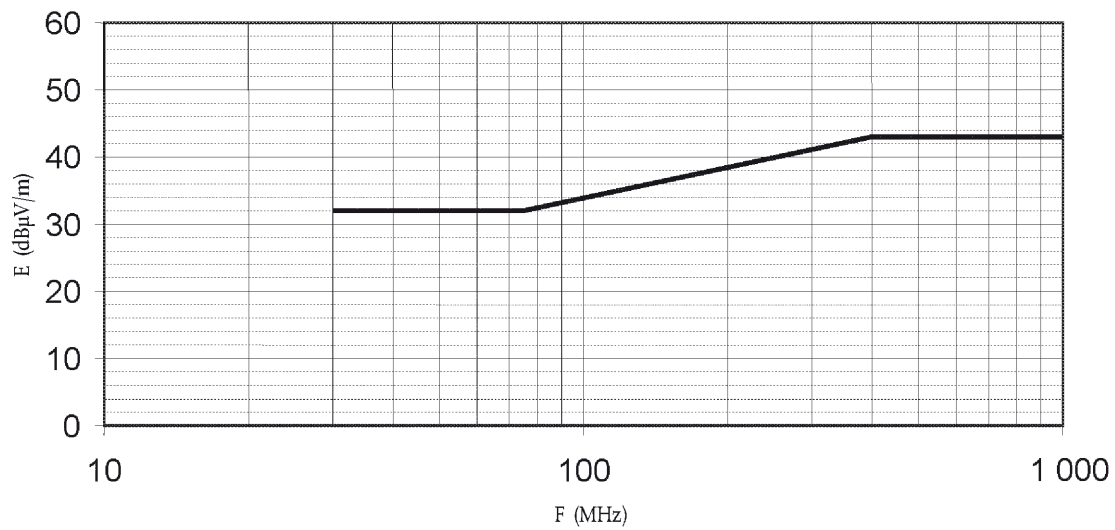

Frequency — megahertz — logarithmic
 (See paragraph 6.3.2.2 of this Regulation)

Appendix 6

Electrical/electronic sub-assembly

Broadband reference limits

Limit E (dB μ V/m) at frequency F (MHz)		
30-75 MHz	75-400 MHz	400-1 000 MHz
$E = 62 - 25,13 \log (F/30)$	$E = 52 + 15,13 \log (F/75)$	$E = 63$

ESA radiated emission limit
Broadband type approval limit - 1 m
Quasi-peak detector - 120 kHz bandwidth

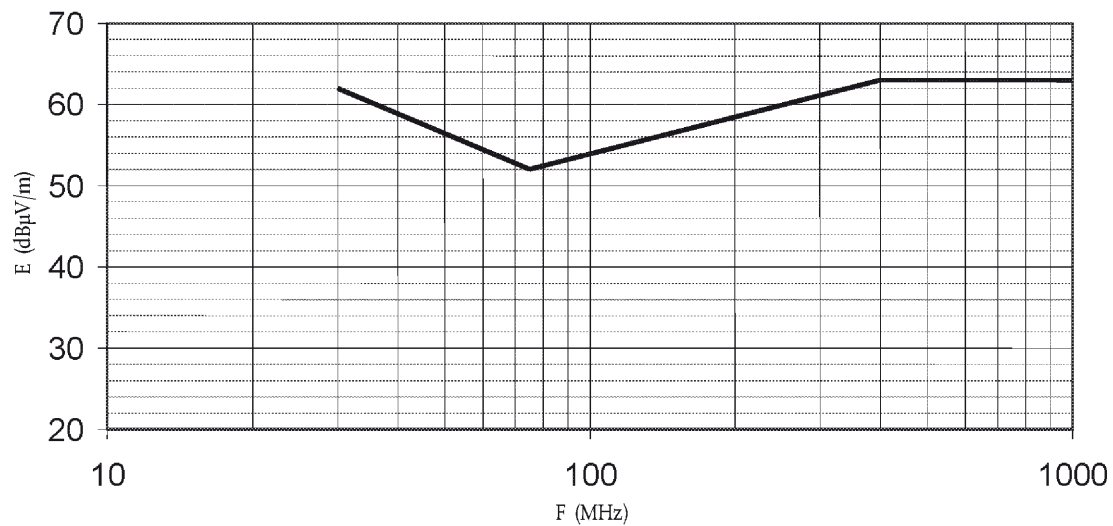

Frequency — megahertz — logarithmic
 (See paragraph 6.5.2.1 of this Regulation)

Appendix 7

Electrical/electronic sub-assembly

Narrowband reference limits

Limit E (dB μ V/m) at frequency F (MHz)		
30-75 MHz	75-400 MHz	400-1 000 MHz
$E = 52 - 25,13 \log (F/30)$	$E = 42 + 15,13 \log (F/75)$	$E = 53$

ESA radiated emission limit
Narrowband type approval limit - 1 m
Average detector - 120 kHz bandwidth

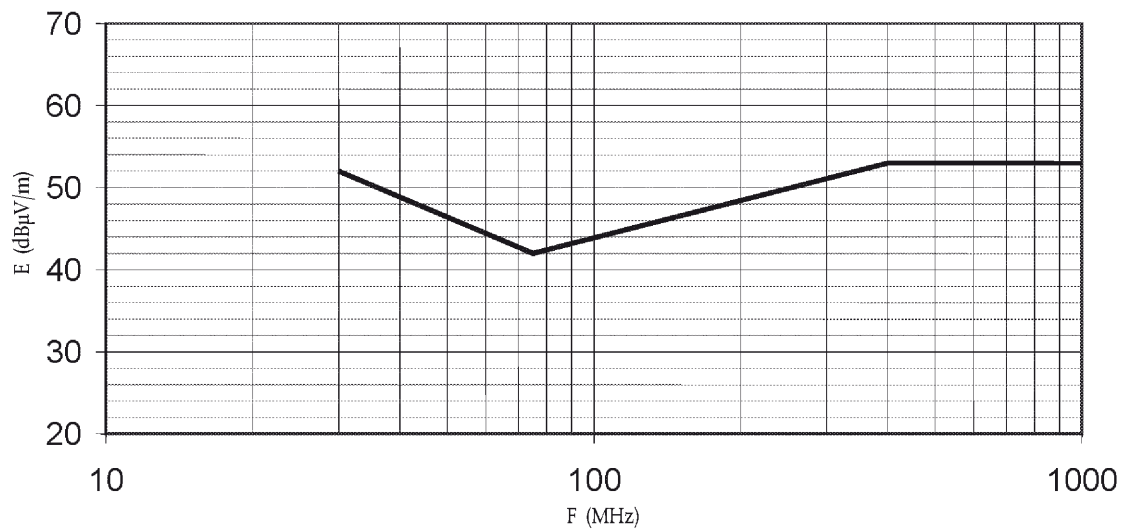

Frequency — megahertz — logarithmic
 (See paragraph 6.6.2.1 of this Regulation)

ANNEX 1

EXAMPLES OF APPROVAL MARKS

Model A

(See paragraph 5.2 of this Regulation)

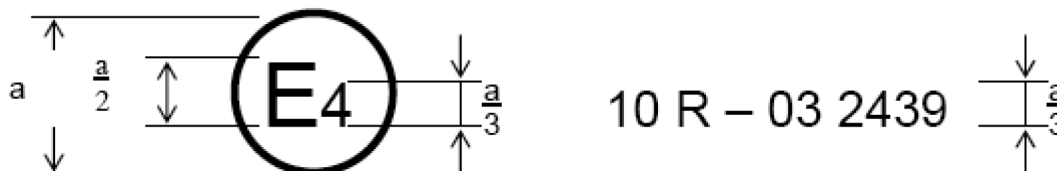

a = 6 mm min

The above approval mark affixed to a vehicle or ESA shows that the vehicle type concerned has, with regard to electromagnetic compatibility, been approved in the Netherlands (E4) pursuant to Regulation No 10 under approval No 032439. The approval number indicates that the approval was granted according to the requirements of Regulation No 10 as amended by the 03 series of amendments.

Model B

(See paragraph 5.2 of this Regulation)

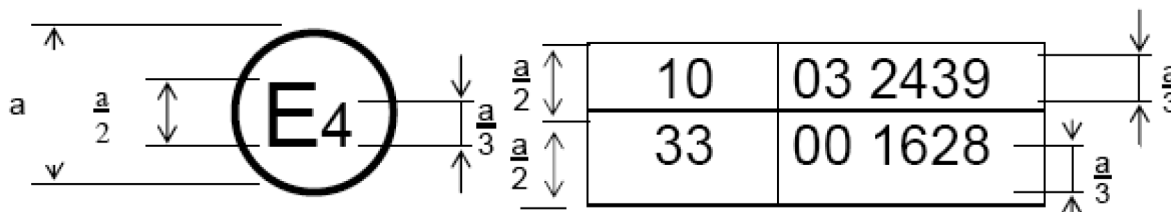

a = 6 mm min

The above approval mark affixed to a vehicle or ESA shows that the vehicle type concerned has, with regard to electromagnetic compatibility, been approved in the Netherlands (E4) pursuant to Regulations No 10 and No 33 (*). The approval numbers indicate that, at the date when the respective approvals were given, Regulation No 10 included the 03 series of amendments and Regulation No 33 was still in its original form.

(*) The second number is given merely as an example.

ANNEX 2A

INFORMATION DOCUMENT

For type approval of a vehicle with respect to electromagnetic compatibility

The following information shall be supplied in triplicate and shall include a list of contents.

Any drawings shall be supplied in appropriate scale and in sufficient detail on size A4 or in a folder of A4 format.

Photographs, if any, shall show sufficient detail.

If the systems, components or separate technical units have electronic controls, information concerning their performance shall be supplied.

GENERAL

- 1. Make (trade name of manufacturer):
- 2. Type:
- 3. Category of vehicle:
- 4. Name and address of manufacturer:
- Name and address of authorised representative, if any:
- 5. Address(es) of assembly plant(s):

GENERAL CONSTRUCTION CHARACTERISTICS OF THE VEHICLE

- 6. Photograph(s) and/or drawing(s) of a representative vehicle:
- 7. Position and arrangement of the engine:

POWER PLANT

- 8. Manufacturer:
- 9. Manufacturer's engine code as marked on the engine:
- 10. Internal combustion engine:
- 11. Working principle: positive ignition/compression ignition, four-stroke/two stroke (1)
- 12. Number and arrangement of cylinders:
- 13. Fuel feed:
- 14. By fuel injection (compression ignition only): yes/no (1)
- 15. Electronic control unit:
- 16. Make(s):
- 17. Description of the system:
- 18. By fuel injection (positive ignition only): yes/no (1)
- 19. Electrical system:
- 20. Rated voltage: V, positive/negative ground (1)
- 21. Generator:
- 22. Type:
- 23. Ignition:
- 24. Make(s):
- 25. Type(s):
- 26. Working principle:
- 27. LPG fuelling system: yes/no (1)

28. Electronic engine management control unit for LPG fuelling:
29. Make(s):
30. Type(s):
31. NG fuelling system: yes/no ⁽¹⁾
32. Electronic engine management control unit for NG fuelling:
33. Make(s):
34. Type(s):
35. Electric motor:
36. Type (winding, excitation):
37. Operating voltage:
- Gas fuelled engines (in the case of systems laid-out in a different manner, supply equivalent information)
38. Electronic control unit (ECU):
39. Make(s):
40. Type(s):
- TRANSMISSION
41. Type (mechanical, hydraulic, electric, etc.):
42. A brief description of the electrical/electronic components (if any):
- SUSPENSION
43. A brief description of the electrical/electronic components (if any):
- STEERING
44. A brief description of the electrical/electronic components (if any):
- BRAKES
45. Anti-lock braking system: yes/no/optional ⁽¹⁾
46. For vehicles with anti-lock systems, description of system operation (including any electronic parts), electric block diagram, hydraulic or pneumatic circuit plan:
- BODYWORK
47. Type of bodywork:
48. Materials used and methods of construction:
49. Windscreen and other windows:
50. A brief description of the electrical/electronic components (if any) of the window lifting mechanism:
51. Rear-view mirrors (state for each mirror):
52. A brief description of the electronic components (if any) of the adjustment system:
53. Safety belts and/or other restraint systems:
54. A brief description of the electrical/electronic components (if any):
55. Suppression of radio interference:
56. Description and drawings/photographs of the shapes and constituent materials of the part of the body forming the engine compartment and the part of the passenger compartment nearest to it:
57. Drawings or photographs of the position of the metal components housed in the engine compartment (e.g. heating appliances, spare wheel, air filter, steering mechanism, etc.):
58. Table and drawing of radio interference control equipment:

59. Particulars of the nominal value of the direct current resistance and, in the case of resistive ignition cables, of their nominal resistance per metre:

LIGHTING AND LIGHT SIGNALLING DEVICES

60. A brief description of electrical/electronic components other than lamps (if any):

MISCELLANEOUS

61. Devices to prevent unauthorised use of the vehicle:

62. A brief description of the electrical/electronic components (if any):

63. Table of installation and use of RF transmitters in the vehicle(s), if applicable (see paragraph 3.1.8 of this Regulation):

frequency bands [Hz]	max. output power [W]	antenna position at vehicle, specific conditions for installation and/or use

64. Vehicle equipped with 24 GHz short-range radar equipment: yes/no/optional (!).

The applicant for type approval must also supply, where appropriate:

Appendix 1:

A list (with make(s) and type(s) of all electrical and/or electronic components concerned by this Regulation (see paragraphs 2.9 and 2.10 of this Regulation) and not previously listed.

Appendix 2:

Schematics or drawing of the general arrangement of electrical and/or electronic components (concerned by this Regulation) and the general wiring harness arrangement.

Appendix 3:

Description of vehicle chosen to represent the type:

Body style:

Left or right hand drive:

Wheelbase:

Appendix 4:

Relevant test report(s) supplied by the manufacturer from a test laboratory accredited to ISO 17025 and recognised by the Approval Authority for the purpose of drawing up the type approval certificate.

(!) Strike out what does not apply.

ANNEX 2B

INFORMATION DOCUMENT

For type approval of an electric/electronic sub-assembly with respect to electromagnetic compatibility

The following information, if applicable, shall be supplied in triplicate and must include a list of contents. Any drawings shall be supplied in appropriate scale and in sufficient detail on size A4 or on a folder of A4 format. Photographs, if any, shall show sufficient detail.

If the systems, components or separate technical units have electronic controls, information concerning their performance shall be supplied.

1. Make (trade name of manufacturer):
2. Type:
3. Means of identification of type, if marked on the component/separate technical unit: ⁽¹⁾
 - 3.1. Location of that marking:
4. Name and address of manufacturer:
Name and address of authorised representative, if any:
5. In the case of components and separate technical units, location and method of affixing of the approval mark:
6. Address(es) of assembly plant(s):
7. This ESA shall be approved as a component/STU ⁽²⁾
8. Any restrictions of use and conditions for fitting:
9. Electrical system rated voltage:V, positive/negative ⁽²⁾ ground.

Appendix 1:

Description of the ESA chosen to represent the type (electronic block diagram and list of main component constituting the ESA (e.g. make and type of microprocessor, crystal, etc.).

Appendix 2:

Relevant test report(s) supplied by the manufacturer from a test laboratory accredited to ISO 17025 and recognised by the Approval Authority for the purpose of drawing up the type approval certificate.

⁽¹⁾ If the means of identification of type contains characters not relevant to describe the component or separate technical unit types covered by this information document, such characters shall be represented in the documentation by the symbol '?' (e.g. ABC??123??).
⁽²⁾ Delete where not applicable.

ANNEX 3A

COMMUNICATION

(Maximum format: A4 (210 × 297 mm))

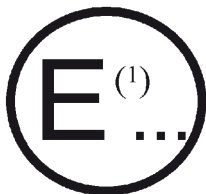

issued by:

Name of administration:

.....
.....
.....

- concerning ⁽²⁾: APPROVAL GRANTED
- APPROVAL EXTENDED
- APPROVAL REFUSED
- APPROVAL WITHDRAWN
- PRODUCTION DEFINITELY DISCONTINUED

of a type of vehicle/component/separate technical unit ⁽²⁾ with regard to Regulation No 10.

Approval number: Extension No:

- 1. Make (trade name of manufacturer):
- 2. Type and general commercial description(s):
- 3. Means of identification of type, if marked on the vehicle/component/separate technical unit ⁽²⁾:
 - 3.1. Location of that marking:
- 4. Category of vehicle:
- 5. Name and address of manufacturer:
- 6. In the case of components and separate technical units, location and method of affixing of the approval mark:
- 7. Address(es) of assembly plant(s):
- 8. Additional information (where applicable): see Appendix
- 9. Technical Service responsible for carrying out the tests:
.....
- 10. Date of test report:
- 11. Number of test report:
- 12. Remarks (if any): see Appendix

13. Place:
14. Date:
15. Signature:
16. The index to the information package lodged with the Approval Authority, which may be obtained on request is attached
17. Reasons for extension:

Appendix to type-approval communication form No ... concerning the type-approval of a vehicle under Regulation No 10

1. Additional information:
2. Special devices for the purpose of Annex 4 to this Regulation (if applicable) (e.g.):
3. Electrical system rated voltage: V. pos/neg ground ⁽²⁾
4. Type of bodywork:
5. List of electronic systems installed in the tested vehicle(s) not limited to the items in the information document:
- 5.1. Vehicle equipped with 24 GHz short-range radar equipment: yes/no/optional ⁽²⁾
6. Laboratory accredited to ISO 17025 and recognised by the Approval Authority responsible for carrying out the tests:
7. Remarks: (e.g. valid for both left-hand drive and right-hand drive vehicles):

—

⁽¹⁾ Distinguishing number of the country which issued/extended/refused/withdrew approval (see Regulation provisions on approval).

⁽²⁾ Strike out what does not apply.

ANNEX 3B

COMMUNICATION

(Maximum format: A4 (210 × 297 mm))

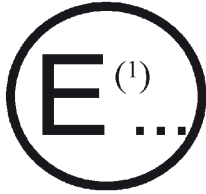

issued by:

Name of administration:

.....
.....
.....

- concerning ⁽²⁾: APPROVAL GRANTED
- APPROVAL EXTENDED
- APPROVAL REFUSED
- APPROVAL WITHDRAWN
- PRODUCTION DEFINITELY DISCONTINUED

of a type of electrical/electronic sub-assembly ⁽²⁾ with regard to Regulation No 10.

Approval No Extension No

1. Make (trade name of manufacturer):
2. Type and general commercial description(s):
3. Means of identification of type, if marked on the vehicle/component/separate technical unit ⁽²⁾:
 - 3.1. Location of that marking:
4. Category of vehicle:
5. Name and address of manufacturer:
6. In the case of components and separate technical units, location and method of affixing of the ECE approval mark:
7. Address(es) of assembly plant(s):
8. Additional information (where applicable): see Appendix
9. Technical Service responsible for carrying out the tests:
.....
10. Date of test report:
11. No of test report:
12. Remarks (if any): see Appendix

- 13. Place:
- 14. Date:
- 15. Signature:
- 16. The index to the information package lodged with the Approval Authority, which may be obtained on request, is attached.
- 17. Reasons for extension:

Appendix to type-approval communication form No ... concerning the type-approval of an electrical/electronic sub-assembly under Regulation No 10

- 1. Additional information:
- 1.1. Electrical system rated voltage: V. pos/neg ground ⁽²⁾
- 1.2. This ESA can be used on any vehicle type with the following restrictions:
- 1.2.1. Installation conditions, if any:
- 1.3. This ESA can be used only on the following vehicle types:
- 1.3.1. Installation conditions, if any:
- 1.4. The specific test method(s) used and the frequency ranges covered to determine immunity were: (Please specify precise method used from Annex 9):
- 1.5. Laboratory accredited to ISO 17025 and recognised by the Approval Authority responsible for carrying out the tests:
- 2. Remarks:

⁽¹⁾ Distinguishing number of the country which issued/extended/refused/withdrew approval (see Regulation provisions on approval).
⁽²⁾ Strike out what does not apply.

ANNEX 3C

ATTESTATION WITH REGARD TO PARAGRAPH 3.2.9

(maximum format: A4 (210 × 297 mm))

Applicant:

General description of product:

Information submitted by the applicant:

This ESA can be used on any vehicle type with the following restrictions:

Installation conditions, if any:

We confirm that the product described above is not immunity related according to Regulation No 10. Any testing according to immunity as defined in this Regulation is not required.

Technical Service responsible for evaluation:

Place:

Date:

Signature:

ANNEX 4

Method of measurement of radiated broadband electromagnetic emissions from vehicles

1. GENERAL

1.1. The test method described in this Annex shall only be applied to vehicles.

1.2. Test method

This test is intended to measure the broadband emissions generated by electrical or electronic systems fitted to the vehicle (e.g. ignition system or electric motors).

If not otherwise stated in this Annex the test shall be performed according to CISPR 12 (amendment 1, fifth edition 2005).

2. VEHICLE STATE DURING TESTS

2.1. Engine

The engine shall be in operation according to CISPR 12 (amendment 1, fifth edition 2005) clause 5.3.2.

2.2. Other vehicle systems

All equipment capable of generating broadband emissions which can be switched on permanently by the driver or passenger should be in operation in maximum load, e.g. wiper motors or fans. The horn and electric window motors are excluded because they are not used continuously.

3. MEASURING LOCATION

3.1. As an alternative to the requirements of CISPR 12 (amendment 1, fifth edition 2005) for vehicles of category L the test surface may be any location that fulfils the conditions shown in the figure 1 in the Appendix of this Annex. In this case the measuring equipment must lie outside the part shown in the figures 1 and 2 of Appendix 1 of this Annex.

3.2. Enclosed test facilities may be used if correlation can be shown between the results obtained in the enclosed test facility and those obtained at an outdoor site. Enclosed test facilities do not need to meet the dimensional requirements of the outdoor site other than the distance from the antenna to the vehicle and the height of the antenna.

4. TEST REQUIREMENTS

4.1. The limits apply throughout the frequency range 30 to 1 000 MHz for measurements performed in a semi anechoic chamber or an outdoor test site.

4.2. Measurements can be performed with either quasi-peak or peak detectors. The limits given in paragraphs 6.2 and 6.5 of this Regulation are for quasi-peak detectors. If peak detectors are used a correction factor of 20 dB as defined in CISPR 12 (amendment 1, fifth edition 2005) shall be applied.

4.3. Measurements

The Technical Service shall perform the test at the intervals specified in the CISPR 12 (amendment 1, fifth edition 2005) standard throughout the frequency range 30 to 1 000 MHz.

Alternatively, if the manufacturer provides measurement data for the whole frequency band from a test laboratory accredited to the applicable parts of ISO 17025 (first edition 1999) and recognised by the Approval Authority, the Technical Service may divide the frequency range in 14 frequency bands 30-34, 34-45, 45-60, 60-80, 80-100, 100-130, 130-170, 170-225, 225-300, 300-400, 400-525, 525-700, 700-850, 850-1 000 MHz and perform tests at the 14 frequencies giving the highest emission levels within each band to confirm that the vehicle meets the requirements of this Annex.

In the event that the limit is exceeded during the test, investigations shall be made to ensure that this is due to the vehicle and not to background radiation.

4.4. Readings

The maximum of the readings relative to the limit (horizontal and vertical polarisation and antenna location on the left and right-hand sides of the vehicle) in each of the 14 frequency bands shall be taken as the characteristic reading at the frequency at which the measurements were made.

Appendix

Figure 1

Clear horizontal surface free of electromagnetic reflection delimitation of the surface defined by an ellipse

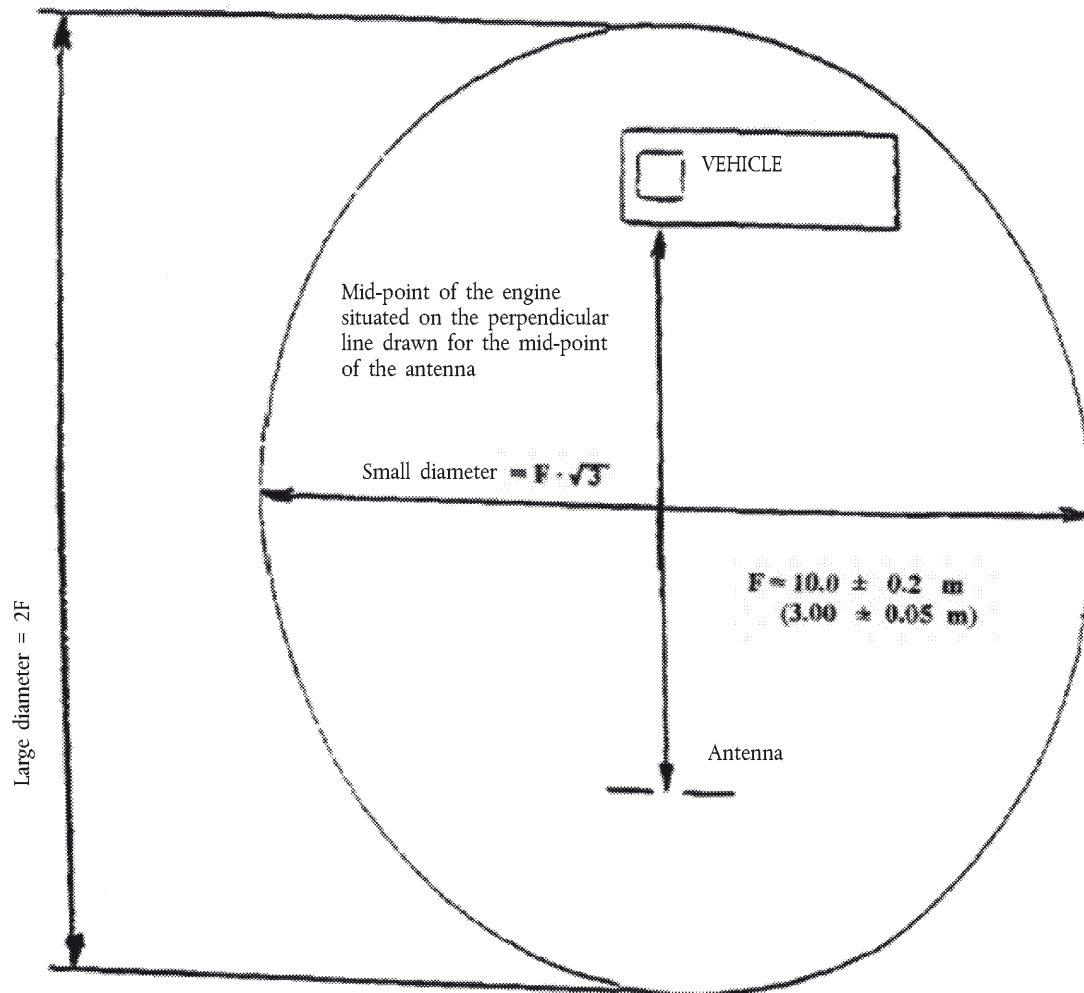
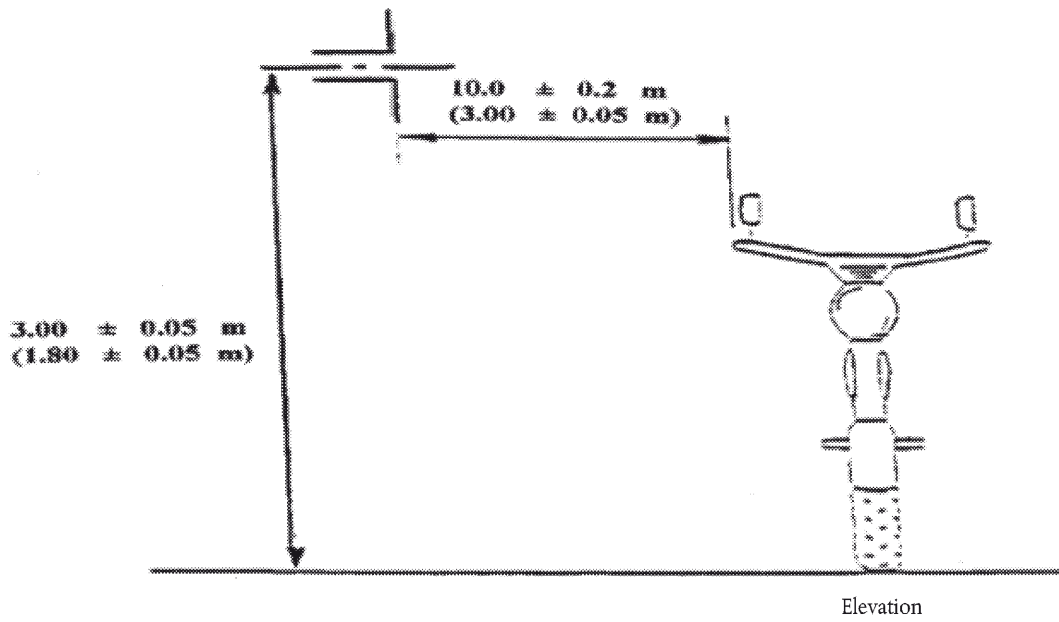
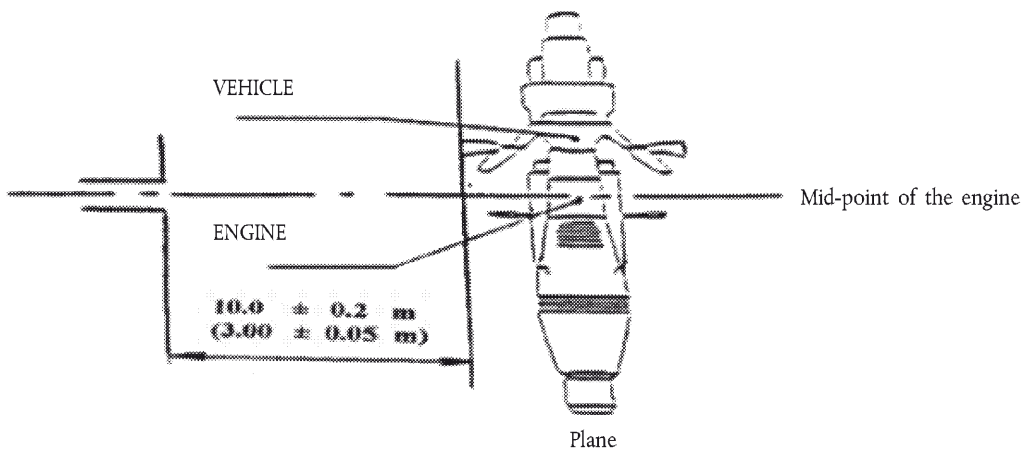

Figure 2

Position of antenna in relation to the vehicle



Dipole antenna in position to measure the vertical radiation components



Dipole antenna in position to measure the horizontal radiation components

ANNEX 5

Method of measurement of radiated narrowband electromagnetic emissions from vehicles

1. GENERAL

1.1. The test method described in this Annex shall only be applied to vehicles.

1.2. Test method

This test is intended to measure the narrowband electromagnetic emissions such as might emanate from micro-processor-based systems or other narrowband source.

If not otherwise stated in this Annex the test shall be performed according to CISPR 12 (amendment 1, fifth edition 2005) or to CISPR 25 (second edition 2002).

1.3. As an initial step the levels of emissions in the Frequency Modulation (FM) band (76 to 108 MHz) shall be measured at the vehicle broadcast radio antenna with an average detector. If the level specified in paragraph 6.3.2.4 of this Regulation is not exceeded, then the vehicle shall be deemed to comply with the requirements of this Annex in respect of that frequency band and the full test shall not be carried out.

1.4. As an alternative for vehicles of category L the measurement location can be chosen according to Annex 4, paragraphs 3.1 and 3.2.

2. VEHICLE STATE DURING TESTS

2.1. The ignition switch shall be switched on. The engine shall not be operating.

2.2. The vehicle's electronic systems shall all be in normal operating mode with the vehicle stationary.

2.3. All equipment which can be switched on permanently by the driver or passenger with internal oscillators > 9 kHz or repetitive signals should be in normal operation.

3. TEST REQUIREMENTS

3.1. The limits apply throughout the frequency range 30 to 1 000 MHz for measurements performed in a semi anechoic chamber or an outdoor test site.

3.2. Measurements shall be performed with an average detector.

3.3. Measurements

The Technical Service shall perform the test at the intervals specified in the CISPR 12 (amendment 1, fifth edition 2005) standard throughout the frequency range 30 to 1 000 MHz.

Alternatively, if the manufacturer provides measurement data for the whole frequency band from a test laboratory accredited to the applicable parts of ISO 17025 (first edition 1999) and recognised by the Approval Authority, the Technical Service may divide the frequency range in 14 frequency bands 30-34, 34-45, 45-60, 60-80, 80-100, 100-130, 130-170, 170-225, 225-300, 300-400, 400-525, 525-700, 700-850, 850-1 000 MHz and perform tests at the 14 frequencies giving the highest emission levels within each band to confirm that the vehicle meets the requirements of this Annex.

In the event that the limit is exceeded during the test, investigations shall be made to ensure that this is due to the vehicle and not to background radiation including broadband radiation from any ESA.

3.4. Readings

The maximum of the readings relative to the limit (horizontal and vertical polarisation and antenna location on the left and right-hand sides of the vehicle) in each of the 14 frequency bands shall be taken as the characteristic reading at the frequency at which the measurements were made.

ANNEX 6

Method of testing for immunity of vehicles to electromagnetic radiation

1. GENERAL

1.1. The test method described in this Annex shall only be applied to vehicles.

1.2. Test method

This test is intended to demonstrate the immunity of the vehicle electronic systems. The vehicle shall be subject to electromagnetic fields as described in this Annex. The vehicle shall be monitored during the tests.

If not otherwise stated in this Annex the test shall be performed according to ISO 11451-2, third edition 2005.

1.3. Alternative test methods

The test may be alternatively performed in an outdoor test site for all vehicles. The test facility shall comply with (national) legal requirements regarding the emission of electromagnetic fields.

If a vehicle is longer than 12 m and/or wider than 2,60 m and/or higher than 4,00 m, BCI (bulk current injection) method according to ISO 11451-4 (first edition 1995) can be used in the frequency range 20 to 2 000 MHz with levels defined in paragraph 6.7.2.1 of this Regulation.

2. VEHICLE STATE DURING TESTS

2.1. The vehicle shall be in an unladen condition except for necessary test equipment.

2.1.1. The engine shall normally turn the driving wheels at a steady speed of 50 km/h if there is no technical reason due to the vehicle to define a different condition. For vehicles of categories L₁ and L₂ the steady speed shall normally be turned at 25 km/h. The vehicle shall be on an appropriately loaded dynamometer or alternatively supported on insulated axle stands with minimum ground clearance if no dynamometer is available. Where appropriate, transmission shafts, belts or chains may be disconnected (e.g. trucks, two- and three-wheel vehicles).

2.1.2. Basic vehicle conditions

The paragraph defines minimum test conditions (as far as applicable) and failures criteria for vehicle immunity tests. Other vehicle systems, which can affect immunity related functions must be tested in a way to be agreed between manufacturer and Technical Service.

'50 km/h cycle' vehicle test conditions	Failure criteria
Vehicle speed 50 km/h (respectively 25 km/h for L ₁ , L ₂ vehicles) ± 20 per cent (vehicle driving the rollers). If the vehicle is equipped with a cruise control system, it shall be operational.	Speed variation greater than ± 0 per cent of the nominal speed. In case of automatic gearbox: change of gear ratio inducing a speed variation greater than ± 10 per cent of the nominal speed.
Dipped beams ON (manual mode)	Lighting OFF
Front wiper ON (manual mode) maximum speed	Complete stop of front wiper
Direction indicator on driver's side ON	Frequency change (lower than 0,75 Hz or greater than 2,25 Hz). Duty cycle change (lower than 25 per cent or greater than 75 per cent).
Adjustable suspension in normal position	Unexpected significant variation
Driver's seat and steering wheel in medium position	Unexpected variation greater than 10 per cent of total range
Alarm unset	Unexpected activation of alarm
Horn OFF	Unexpected activation of horn
Airbag and safety restraint systems operational with inhibited passenger airbag if this function exists	Unexpected activation
Automatic doors closed	Unexpected opening
Adjustable endurance brake lever in normal position	Unexpected activation

'Brake cycle' vehicle test conditions	Failure criteria
To be defined in brake cycle test plan. This must include operation of the brake pedal (unless there are technical reasons not to do so) but not necessarily an anti-lock brake system action.	Stop lights inactivated during cycle Brake warning light ON with loss of function. Unexpected activation

2.1.3. All equipment which can be switched on permanently by the driver or passenger should be in normal operation.

2.1.4. All other systems which affect the driver's control of the vehicle shall be (on) as in normal operation of the vehicle.

2.2. If there are vehicle electrical/electronic systems which form an integral part of the direct control of the vehicle, which will not operate under the conditions described in paragraph 4.1, it will be permissible for the manufacturer to provide a report or additional evidence to the Technical Service that the vehicle electrical/electronic system meets the requirements of this Regulation. Such evidence shall be retained in the type approval documentation.

2.3. Only non-perturbing equipment shall be used while monitoring the vehicle. The vehicle exterior and the passenger compartment shall be monitored to determine whether the requirements of this Annex are met (e.g. by using a video camera(s), a microphone, etc.).

3. REFERENCE POINT

3.1. For the purposes of this Annex, the reference point is the point at which the field strength shall be established and shall be defined as follows:

3.2. For category M, N, O vehicles according to ISO 11451-2, third edition 2005.

3.3. For category L vehicles:

3.3.1. at least 2 m horizontally from the antenna phase centre or at least 1 m vertically from the radiating elements of a transmission-line-system (TLS);

3.3.2. on the vehicle's centre line (plane of longitudinal symmetry);

3.3.3. at a height of $1,0 \pm 0,05$ m above the plane on which the vehicle rests or $2,0 \pm 0,05$ m if the minimum height of the roof of any vehicle in the model range exceeds 3,0 m;

3.3.4. either at $1,0 \pm 0,2$ m behind the vertical centreline of the vehicle's front wheel (point C in figure 1 of Appendix 1 of this Annex) in the case of three-wheeled vehicles,

or at $0,2 \pm 0,2$ m behind the vertical centreline of the vehicle's front wheel (point D in figure 2 of Appendix 1 of this Annex) in the case of two-wheeled vehicles;

3.3.5. If it is decided to radiate the rear of the vehicle, the reference point shall be established as in paragraphs 3.3.1 to 3.3.4. The vehicle shall then be installed facing away from the antenna and positioned as if it had been horizontally rotated 180 around its centre point, i.e. such that the distance from the antenna to the nearest part of the outer body of the vehicle remains the same. This is illustrated in figure 3 of Appendix 1 of this Annex.

4. TEST REQUIREMENTS

4.1. Frequency range, dwell times, polarisation

The vehicle shall be exposed to electromagnetic radiation in the 20 to 2 000 MHz frequency ranges in vertical polarisation.

The test signal modulation shall be:

(a) AM (amplitude modulation), with 1 kHz modulation and 80 per cent modulation depth in the 20 to 800 MHz frequency range; and

(b) PM (pulse modulation), t on 577 μ s, period 4 600 μ s in the 800 to 2 000 MHz frequency range,

if not otherwise agreed between Technical Service and vehicle manufacturer.

Frequency step size and dwell time shall be chosen according to ISO 11451-1, third edition 2005.

- 4.1.1. The Technical Service shall perform the test at the intervals specified in ISO 11451-1, third edition 2005 throughout the frequency range 20 to 2 000 MHz.

Alternatively, if the manufacturer provides measurement to data for the whole frequency band from a test laboratory accredited to the applicable parts of ISO 17025 (first edition 1999) and recognised by the Approval Authority, the Technical Service may choose a reduced number of spot frequencies in the range, e.g. 27, 45, 65, 90, 120, 150, 190, 230, 280, 380, 450, 600, 750, 900, 1 300, and 1 800 MHz to confirm that the vehicle meets the requirements of this Annex.

If a vehicle fails the test defined in this Annex, it must be verified as having failed under the relevant test conditions and not as a result of the generation of uncontrolled fields.

5. GENERATION OF REQUIRED FIELD STRENGTH

5.1. Test methodology

- 5.1.1. The substitution method according to ISO 11451-1, third edition 2005 shall be used to establish the test field conditions.

5.1.2. Calibration

For TLS one field probe at the facility reference point shall be used.

For antennas four field probes at the facility reference line shall be used.

5.1.3. Test phase

The vehicle shall be positioned with the centre line of the vehicle on the facility reference point or line. The vehicle shall normally face a fixed antenna. However, where the electronic control units and the associated wiring harness are predominantly in the rear of the vehicle, the test should normally be carried out with the vehicle facing away from the antenna. In the case of long vehicles (i.e. excluding vehicles of categories L, M₁ and N₁), which have electronic control units and associated wiring harness predominantly towards the middle of the vehicle, a reference point may be established based on either the right side surface or the left side surface of the vehicle. This reference point shall be at the midpoint of the vehicle's length or at one point along the side of the vehicle chosen by the manufacturer in conjunction with the Competent Authority after considering the distribution of electronic systems and the layout of any wiring harness.

Such testing may only take place if the physical construction of the chamber permits. The antenna location must be noted in the test report.

—

Appendix

Figure 1

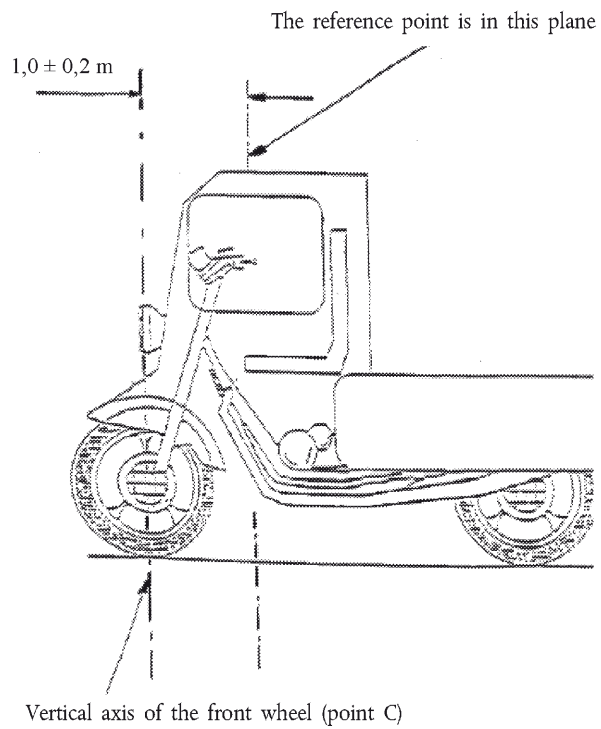

Figure 2

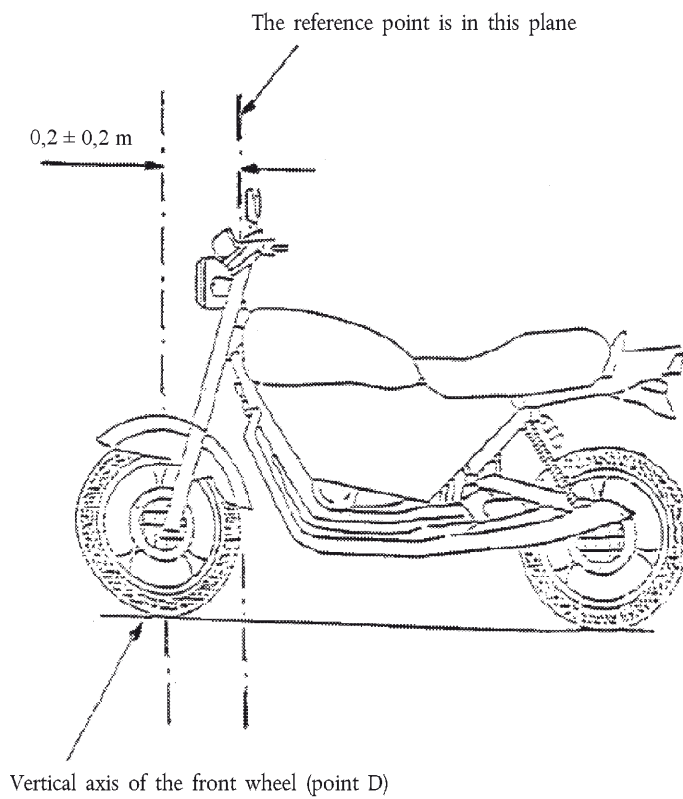
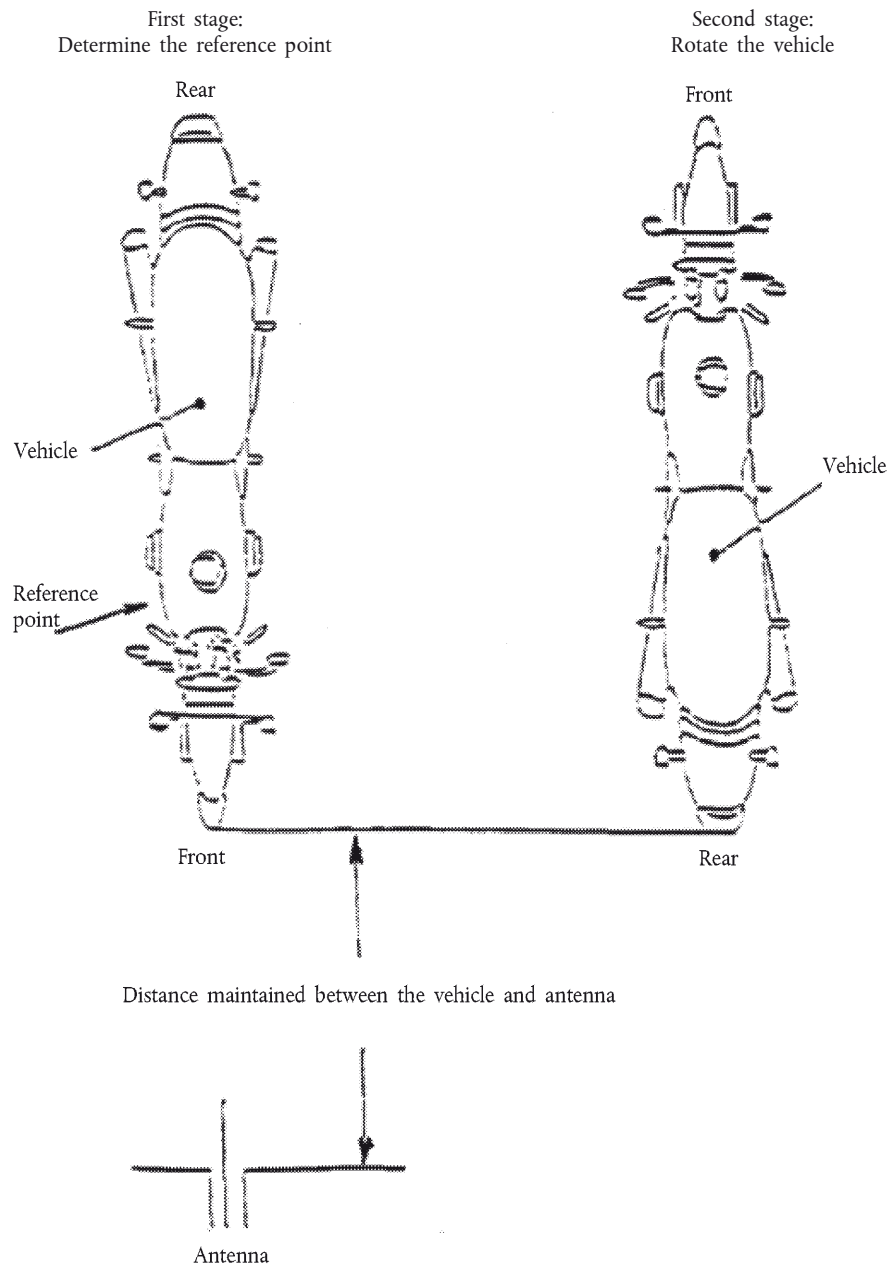

Figure 3



ANNEX 7

Method of measurement of radiated broadband electromagnetic emissions from electrical/electronic sub-assemblies

1. GENERAL

1.1. The test method described in this Annex may be applied to ESAs, which may be subsequently fitted to vehicles, which comply with Annex 4.

1.2. Test method

This test is intended to measure broadband electromagnetic emissions from ESAs (e.g. ignition systems, electric motor, etc.).

If not otherwise stated in this Annex the test shall be performed according CISPR 25 (second edition 2002).

2. ESA STATE DURING TESTS

2.1. The ESA under test shall be in normal operation mode, preferably in maximum load.

3. TEST ARRANGEMENTS

3.1. The test shall be performed according to CISPR 25 (second edition 2002) clause 6.4 — ALSE method.

3.2. Alternative measuring location

As an alternative to an absorber lined shielded enclosure (ALSE) an open area test site (OATS), which complies with the requirements of CISPR 16-1 (second edition 2002) may be used (see Appendix of this Annex).

3.3. Ambient

To ensure that there is no extraneous noise or signal of a magnitude sufficient to affect materially the measurement, measurements shall be taken before or after the main test. In this measurement, the extraneous noise or signal shall be at least 6 dB below the limits of interference given in paragraph 6.5.2.1 of this Regulation, except for intentional narrowband ambient transmissions.

4. TEST REQUIREMENTS

4.1. The limits apply throughout the frequency range 30 to 1 000 MHz for measurements performed in a semi anechoic chamber or an outdoor test site.

4.2. Measurements can be performed with either quasi-peak or peak detectors. The limits given in paragraphs 6.2 and 6.5 of this Regulation are for quasi-peak detectors. If peak detectors are used a correction factor of 20 dB as defined in CISPR 12 (fifth edition 2001) shall be applied.

4.3. Measurements

The Technical Service shall perform the test at the intervals specified in the CISPR 25 (second edition 2002) standard throughout the frequency range 30 to 1 000 MHz.

Alternatively, if the manufacturer provides measurement to data for the whole frequency band from a test laboratory accredited to the applicable parts of ISO 17025 (first edition 1999) and recognised by the Approval Authority, the Technical Service may divide the frequency range in 13 frequency bands 30-50, 50-75, 75-100, 100-130, 130-165, 165-200, 200-250, 250-320, 320-400, 400-520, 520-660, 660-820, 820-1 000 MHz and perform tests at the 13 frequencies giving the highest emission levels within each band to confirm that the ESA meets the requirements of this Annex.

In the event that the limit is exceeded during the test, investigations shall be made to ensure that this is due to the ESA and not to background radiation.

4.4. Readings

The maximum of the readings relative to the limit (horizontal/vertical polarisation) in each of the 13 frequency bands shall be taken as the characteristic reading at the frequency at which the measurements were made.

Appendix

Figure 1

Open area test site: Electrical/electronic sub-assembly test area boundary
Level clear area free from electromagnetic reflecting surfaces

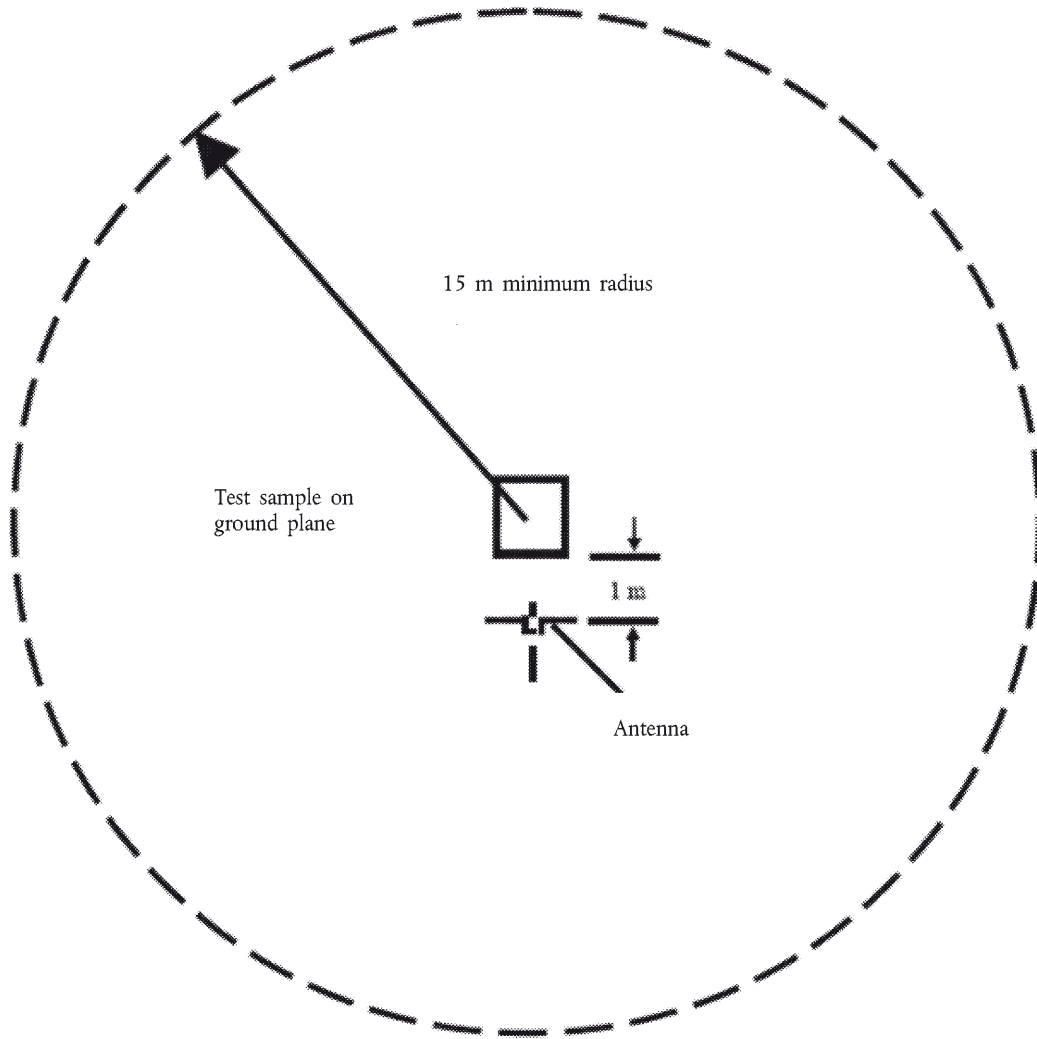

ANNEX 8

Method of measurement of radiated narrowband electromagnetic emissions from electrical/electronic sub-assemblies

1. GENERAL

1.1. The test method described in this Annex may be applied to ESAs, which may be subsequently fitted to vehicles, which comply, with Annex 4.

1.2. Test method

This test is intended to measure the narrowband electromagnetic emissions such as might emanate from a microprocessor-based system.

If not otherwise stated in this Annex the test shall be performed according to CISPR 25 (second edition 2002).

2. ESA STATE DURING TESTS

The ESA under test shall be in normal operation mode.

3. TEST ARRANGEMENTS

3.1. The test shall be performed according CISPR 25 (second edition 2002) clause 6.4 — ALSE method.

3.2. Alternative measuring location

As an alternative to an absorber lined shielded enclosure (ALSE) an open area test site (OATS) which complies with the requirements of CISPR 16-1 (second edition 2002) may be used (see Appendix of Annex 7).

3.3. Ambient

To ensure that there is no extraneous noise or signal of a magnitude sufficient to affect materially the measurement, measurements shall be taken before or after the main test. In this measurement, the extraneous noise or signal shall be at least 6 dB below the limits of interference given in paragraph 6.5.2.1 of this Regulation, except for intentional narrowband ambient transmissions.

4. TEST REQUIREMENTS

4.1. The limits apply throughout the frequency range 30 to 1 000 MHz for measurements performed in semi anechoic chambers or outdoor test sites.

4.2. Measurements shall be performed with an average detector.

4.3. Measurements

The Technical Service shall perform the test at the intervals specified in the CISPR 12 (fifth edition 2001) standard throughout the frequency range 30 to 1 000 MHz.

Alternatively, if the manufacturer provides measurement to data for the whole frequency band from a test laboratory accredited to the applicable parts of ISO 17025 (first edition 1999) and recognised by the Approval Authority, the Technical Service may divide the frequency range in 13 frequency bands 30-50, 50-75, 75-100, 100-130, 130-165, 165-200, 200-250, 250-320, 320-400, 400-520, 520-660, 660-820, 820-1 000 MHz and perform tests at the 13 frequencies giving the highest emission levels within each band to confirm that the ESA meets the requirements of this Annex. In the event that the limit is exceeded during the test, investigations shall be made to ensure that this is due to the ESA and not to background radiation including broadband radiation from the ESA.

4.4. Readings

The maximum of the readings relative to the limit (horizontal/vertical polarisation) in each of the 13 frequency bands shall be taken as the characteristic reading at the frequency at which the measurements were made.

ANNEX 9

Method(s) of testing for immunity of electrical/electronic sub-assemblies to electromagnetic radiation

1. GENERAL

1.1. The test method(s) described in this Annex applies to ESAs.

1.2. Test methods

1.2.1. ESAs may comply with the requirements of any combination of the following test methods at the manufacturer's discretion provided that this results in the full frequency range specified in paragraph 3.1 of this Annex being covered:

(a) absorber chamber test according ISO 11452-2, second edition 2004;

(b) TEM cell testing according ISO 11452-3, third edition 2001;

(c) bulk current injection testing according ISO 11452-4, third edition 2005;

(d) stripline testing according ISO 11452-5, second edition 2002;

(e) 800 mm stripline according paragraph 5 of this Annex.

(Frequency range and general test conditions shall be based on ISO 11452-1, third edition 2005).

2. STATE OF ESA DURING TESTS

2.1. The test conditions shall be according ISO 11452-1, third edition 2005.

2.2. The ESA under test shall be switched on and must be stimulated to be in normal operation condition. It shall be arranged as defined in this Annex unless individual test methods dictate otherwise.

2.3. Any extraneous equipment required to operate the ESA under test shall not be in place during the calibration phase. No extraneous equipment shall be closer than 1 m from the reference point during calibration.

2.4. To ensure reproducible measurement results are obtained when tests and measurements are repeated, the test signal generating equipment and its layout shall be to the same specification as that used during each appropriate calibration phase.

2.5. If the ESA under test consists of more than one unit, the interconnecting cables should ideally be the wiring harnesses as intended for use in the vehicle. If these are not available, the length between the electronic control unit and the AN shall be as defined in the standard. All cables in the wiring harness should be terminated as realistically as possible and preferably with real loads and actuators.

3. GENERAL TEST REQUIREMENTS

3.1. Frequency range, dwell times

Measurements shall be made in the 20 to 2 000 MHz frequency range with frequency steps according to ISO 11452-1, third edition 2005.

The test signal modulation shall be:

(a) AM (amplitude modulation), with 1 kHz modulation and 80 per cent modulation depth in the 20 to 800 MHz frequency range;

(b) PM (pulse modulation), t_{on} 577 μ s, period 4 600 μ s in the 800 to 2 000 MHz frequency range,

if not otherwise agreed between Technical Service and ESA manufacturer.

Frequency step size and dwell time shall be chosen according to ISO 11452-1, third edition 2005.

3.2. The Technical Service shall perform the test at the intervals specified in ISO 11452-1, third edition 2005 throughout the frequency range 20 to 2 000 MHz.

Alternatively, if the manufacturer provides measurement to data for the whole frequency band from a test laboratory accredited to the applicable parts of ISO 17025, first edition 1999 and recognised by the Approval Authority, the Technical Service may choose a reduced number of spot frequencies in the range, e.g. 27, 45, 65, 90, 120, 150, 190, 230, 280, 380, 450, 600, 750, 900, 1 300, and 1 800 MHz to confirm that the ESA meets the requirements of this Annex.

- 3.3. If an ESA fails the tests defined in this Annex, it must be verified as having failed under the relevant test conditions and not as a result of the generation of uncontrolled fields.

4. SPECIFIC TEST REQUIREMENTS

4.1. Absorber chamber test

4.1.1. Test method

This test method allows the testing of vehicle electrical/electronic systems by exposing an ESA to electromagnetic radiation generated by an antenna.

4.1.2. Test methodology

The 'substitution method' shall be used to establish the test field conditions according ISO 11452-2, second edition 2004.

The test shall be performed with vertical polarisation.

4.2. TEM cell testing (see Appendix 2 of this Annex)

4.2.1. Test method

The TEM (transverse electromagnetic mode) cell generates homogeneous fields between the internal conductor (septum) and housing (ground plane).

4.2.2. Test methodology

The test shall be performed according ISO 11452-3, third edition 2001.

Depending on the ESA to be tested the Technical Service shall choose the method of maximum field coupling to the ESA or to the wiring harness inside the TEM-cell.

4.3. Bulk current injection testing

4.3.1. Test method

This is a method of carrying out immunity tests by inducing currents directly into a wiring harness using a current injection probe.

4.3.2. Test methodology

The test shall be performed according to ISO 11452-4, third edition 2005 on a test bench. As an alternative the ESA may be tested while installed in the vehicle according to ISO 11451-4 (first edition 1995) with the following characteristics:

- (a) the injection probe shall be positioned in 150 mm distance to the ESA to be tested;
- (b) the reference method shall be used to calculate injected currents from forward power;
- (c) the frequency range of the method is limited by the injection probe specification.

4.4. Stripline testing

4.4.1. Test method

This test method consists of subjecting the wiring harness connecting the components in an ESA to specified field strengths.

4.4.2. Test methodology

The test shall be performed according ISO 11452-5, second edition 2002.

4.5. 800 mm stripline testing

4.5.1. Test method

The stripline consists of two parallel metallic plates separated by 800 mm. Equipment under test is positioned centrally between the plates and subjected to an electromagnetic field (see Appendix 1 of this Annex).

This method can test complete electronic systems including sensors and actuators as well as the controller and wiring loom. It is suitable for apparatus whose largest dimension is less than one third of the plate separation.

4.5.2. Test methodology

4.5.2.1. Positioning of stripline

The stripline shall be housed in a screened room (to prevent external emissions) and positioned 2 m away from walls and any metallic enclosure to prevent electromagnetic reflections. RF absorber material may be used to damp these reflections. The stripline shall be placed on non-conducting supports at least 0,4 m above the floor.

4.5.2.2. Calibration of the stripline

A field-measuring probe shall be positioned within the central one-third of the longitudinal, vertical and transverse dimensions of the space between the parallel plates with the system under test absent.

The associated measuring equipment shall be sited outside the screen room. At each desired test frequency, a level of power shall be fed into the stripline to produce the required field strength at the antenna. This level of forward power, or another parameter directly related to the forward power required to define the field, shall be used for type approval tests unless changes occur in the facilities or equipment, which necessitate this procedure being repeated.

4.5.2.3. Installation of the ESA under test

The main control unit shall be positioned within the central one third of the longitudinal, vertical and transverse dimensions of the space between the parallel plates. It shall be supported on a stand made from non-conducting material.

4.5.2.4. Main wiring loom and sensor/actuator cables

The main wiring loom and any sensor/actuator cables shall rise vertically from the control unit to the top ground plate (this helps to maximise coupling with the electromagnetic field). Then they shall follow the underside of the plate to one of its free edges where they shall loop over and follow the top of the ground plate as far as the connections to the stripline feed. The cables shall then be routed to the associated equipment, which shall be sited in an area outside the influence of the electromagnetic field, e.g.: on the floor of the screened room 1 m longitudinally away from the stripline.

Appendix 1

Figure 1

800 mm Stripline testing

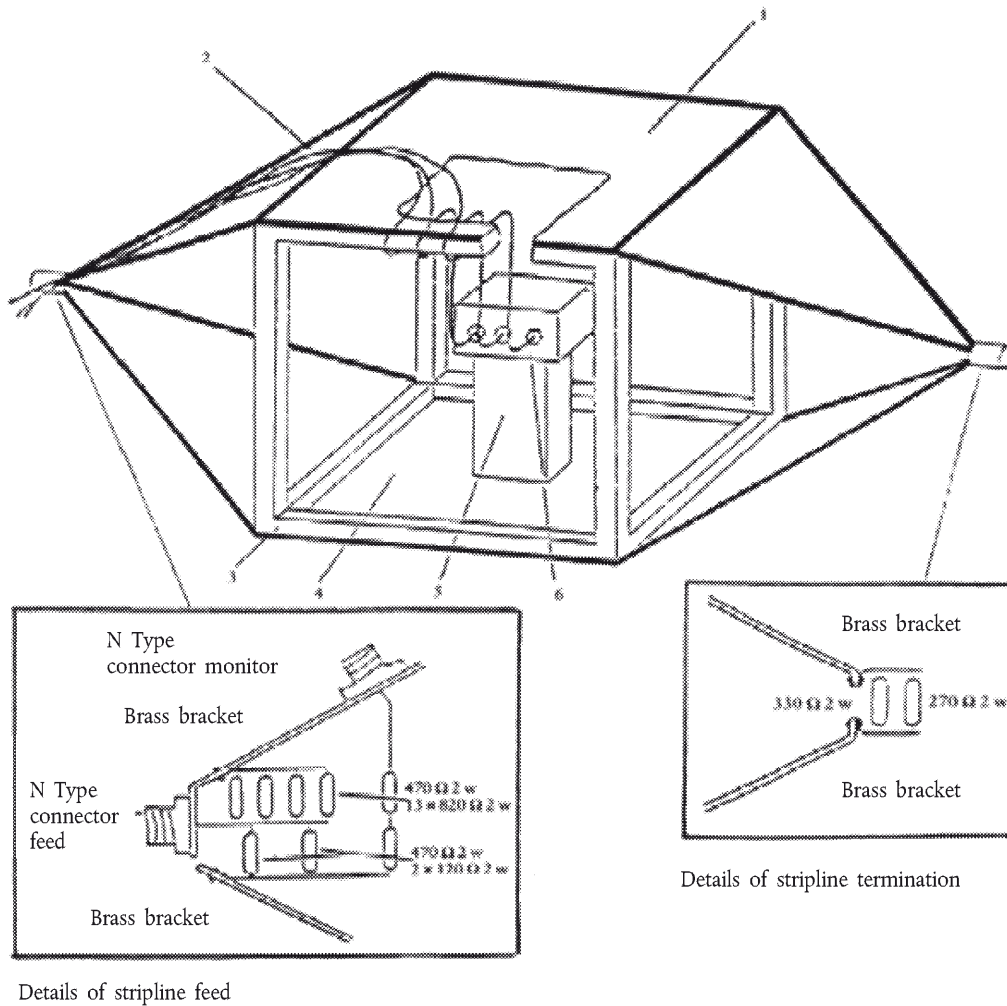

- 1 = Ground plate
- 2 = Main loom and sensor/actuator cables
- 3 = Wooden frame
- 4 = Driven plate
- 5 = Insulator
- 6 = Test object

Figure 2
800 mm stripline dimensions

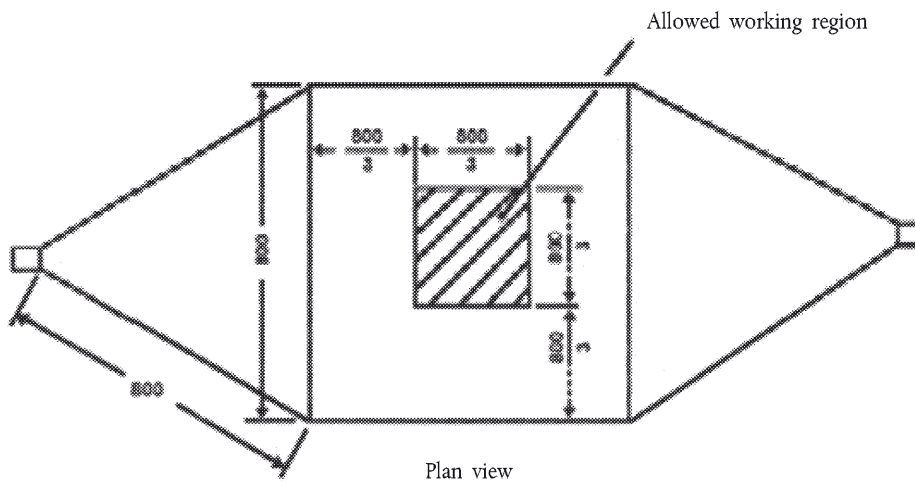
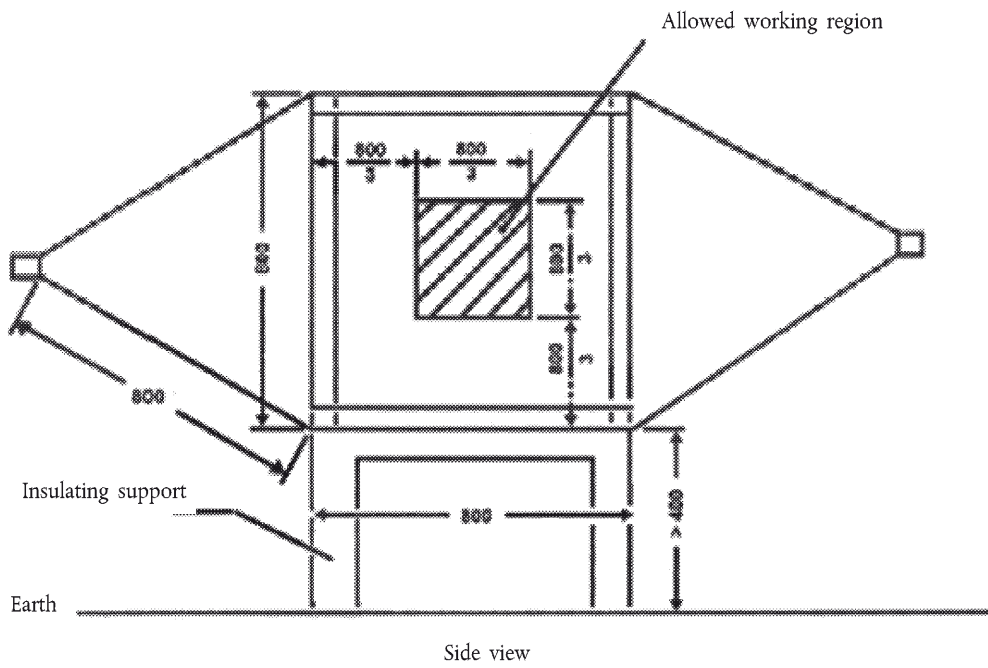

All dimensions in millimetres

*Appendix 2***Typical TEM cell dimensions**

The following table shows the dimensions for constructing a cell with specified upper frequency limits:

Upper frequency (MHz)	Cell form factor W:b	Cell form factor L/W	Plate separation b (cm)	Septum S (cm)
200	1,69	0,66	56	70
200	1,00	1	60	50

ANNEX 10

Method(s) of testing for immunity to and emission of transients of electrical/electronic sub-assemblies

1. GENERAL

This test method shall ensure the immunity of ESAs to conducted transients on the vehicle power supply and limit conducted transients from ESAs to the vehicle power supply.

2. IMMUNITY AGAINST DISTURBANCES CONDUCTED ALONG SUPPLY LINES

Apply the test pulses 1, 2a, 2b, 3a, 3b and 4 according to the International Standard ISO 7637-2:2004 to the supply lines as well as to other connections of ESAs which may be operationally connected to supply lines.

3. EMISSION OF CONDUCTED DISTURBANCES ALONG SUPPLY LINES

Measurement according to the International Standard ISO 7637-2:2004 on supply lines as well as to other connections of ESAs which may be operationally connected to supply lines.
